

OP-AMP POWER SUPPLY

Robert Irwin

An ideal supply for op-amp experimenters and those with solderless breadboards. The ETI-251 provides $\pm 12\text{ V}$ rails at 1 A and solves those 'split rail blues'.



A DUAL RAIL supply is a handy piece of equipment for anyone who is even thinking of playing around with analogue ICs. The ETI-251 is a simple, easy-to-build, low cost supply that will be ideal for breadboarding up circuits which require single or split 12 V rails. The ETI-251 provides regulated positive and negative 12 V rails and can supply up to 0.5 A from each. An overload LED on each rail gives a visual indication when you try to draw too much current from the supply. All the components used are very common and most could probably be found in the average hobbyist's 'bits-and-pieces' draw. The supply is relatively easy to build and should be suitable for even inexperienced constructors, although not recommended as a very first project. The construction section has been made very detailed to accommodate any beginners who wish to build this supply.

Design details

The circuit is designed around the very widely used LM7XXX series of three terminal regulators. The LM7812 and LM7912 provide +12 V and -12 V respectively. Both ICs have built in short circuit fold-back current limiting and thermal protection and are therefore very hardy devices. As well as the internal protection built in to the regulator ICs, several external protection diodes are included in the circuit to guard against any accidental load faults that may otherwise destroy the regulators.

The transformer used is a widely avail-

HOW IT WORKS — ETI-251

The circuit is very simple as the three terminal regulators are basically autonomous, requiring no external circuitry to make them work. Protection from unusual load conditions is needed though. Referring to the circuit diagram, the transformer output is 30 Vac with a centre tap. This gives two 15 Vac signals which are rectified by a D1, 2, 3, 4 which form a full wave bridge rectifier. This produces both a positive and a negative rectified output with reference to the centre tap. The rectified signals are smoothed by C1 and C2 which, with the values chosen, will give a peak output of 21 V and a ripple of about 4 V p-p at 1 A output.

Before going to the regulators, the current is monitored by the overcurrent circuitry. Both the positive and negative circuits are identical (except for the direction of current flow) so we will just look at the positive overcurrent circuit. R1 is in series with the supply current and will develop a voltage across it which is given by Ohm's law, $V=IR$. The emitter of Q1 is connected to the supply side of R1 and the base is connected to the load side. When the load current reaches 0.6 amps, 0.6 V is developed between the base and emitter of Q1 and it begins to turn on. This will allow current to flow through LED2 which will cause it to light and indicate an overcurrent condition. R5 limits the current through the LED to about 15 mA.

IC1 is a positive regulator which takes the unregulated input and gives a regulated +12 V output. IC2 does the same for the negative side and gives a regulated -12 V output. One problem that sometimes occurs when using regulators in a split rail supply is

that of start up under a common load. The negative regulator tends to establish itself first and, under a shared load (particularly a capacitive one), it may drag the output of the positive regulator negative and prevent it starting up. It may also cause the IC to be destroyed. To help prevent this, R3 and D7 are incorporated into the design. This helps the positive regulator start up under common loads by providing isolation of the common pins on the two ICs and, if the output is dragged negative, the current can be shunted by D7 and allow the positive regulator to establish itself. R4 is included in the circuit to maintain a voltage balance between IC1 and IC2. Without R4, the quiescent current in the common terminal (about 6 mA) would raise the output voltage on the positive regulator slightly.

As an added precaution against destruction of the regulators, D8 and D9 prevent any reverse polarity voltages from developing on the outputs of the regulators. D5 and D6 will protect the regulators from any overvoltages on the outputs which may occur when reactive loads are being driven. C6 and C7 are not crucial but provide some filtering to the input of the regulators. C3 and C4 improve the transient response of the regulators and prevent high frequency instabilities. C5 ac couples the power supply earth to the chassis which allows the metal case to act as an electrostatic shield and prevent any rf interference in the supply. There should be no dc connection between chassis and power supply earth. LED1 and R7 provide a power on indication.

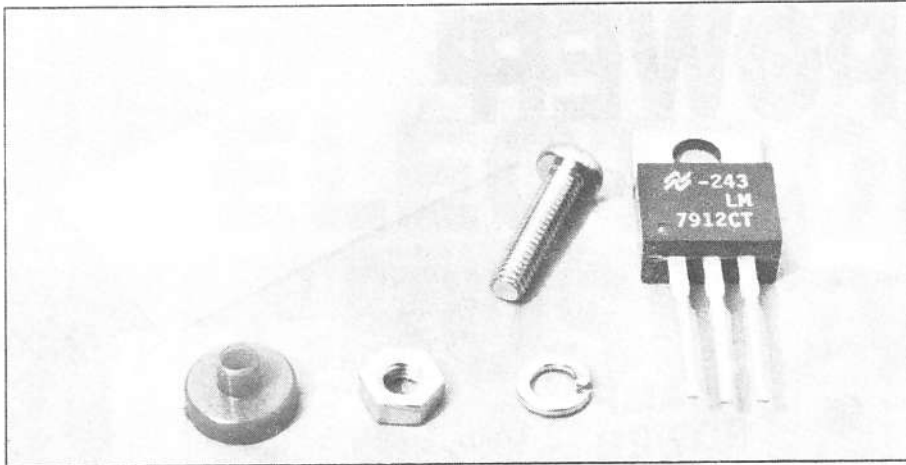

Above: IC mounting hardware. This pic shows the various bits and pieces you will need to mount each regulator. The mica washer is at the top left, and the insulating washer is at the bottom left.
Below: The regulators mounted on the heatsink bracket. The 'messy white stuff' all over the bracket is the thermal grease used to provide good heat transfer.

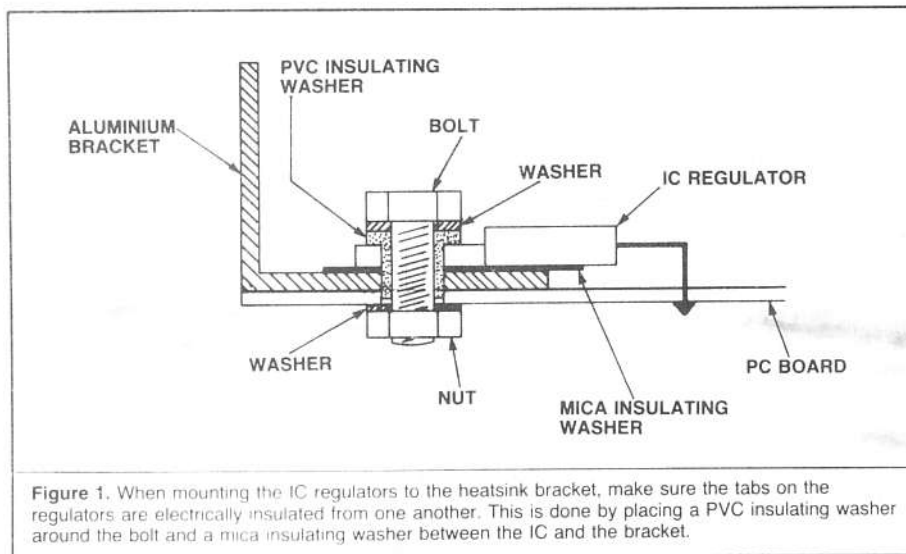
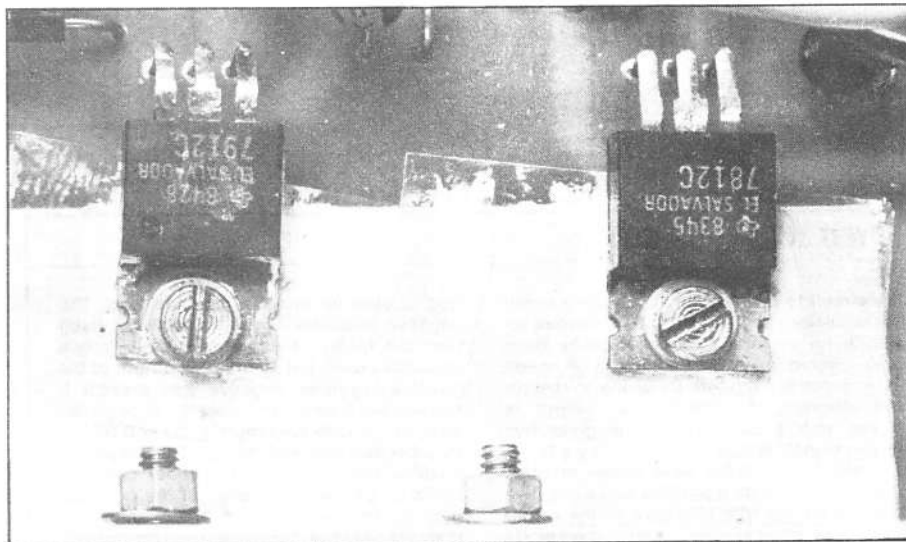

able multi-tapped secondary type which provides 15 V and 30 V taps and is rated at 30 VA maximum. The main reason for the choice of this transformer is that it is cheap and easy to get. It should be noted however, that under a direct short circuit between the positive and negative terminals, the output current will be just over 2 A. The transformer will handle this sort of overload for quite a few minutes without damage but may heat up if the short is left for long periods. This will not be a problem in normal operation but if the supply were, for example, to be used to power a circuit which was to be left running overnight, it would be a good idea to use a transformer with a higher output current rating so that any sustained short that may occur will not thermally stress the transformer. A short from either the positive or negative to ground will only cause about an amp to flow and can be handled indefinitely by the specified transformer. A PL30/60 VA is an ideal substitute but is quite expensive. For most applications, though, the specified transformer will be more than adequate.

Incorporated into the design is an overload indication for each rail. This is set to indicate that a current of 0.6 A or more is being drawn from the rail. This overload in no way damages the supply but is there to indicate excessive current drain which may be cause to investigate the circuit you are powering for shorts.

Construction

The construction of the power supply presents no real problems. However, I will describe the construction in detail for those who may not be as familiar with a soldering iron as others.

It is recommended that the circuit be constructed on the ETI pc board. If you wish (and you know what you're doing) you can, of course, use Veroboard or the like but using the pc board will greatly simplify construction and minimize the chance of a wiring error. Having said that, once you get a pc board check it very carefully for faults on the copper side. The most common faults are broken or shorted tracks caused by problems in the etching stage. If a track is thin, then over-etching or faults in the resist can cause the track to be etched away in parts and thus be open circuit, so check all thin tracks for breaks. Where two tracks come close together, under-etching or dust on the negative can cause the copper between the tracks to remain and thus cause a short so check all points where tracks come close together. Finally, check that all the holes have been drilled. Once you are satisfied that the pc board is in good shape, you can move on to the soldering in of the components.

Referring to the overlay diagram, locate the position of the wire link. This link

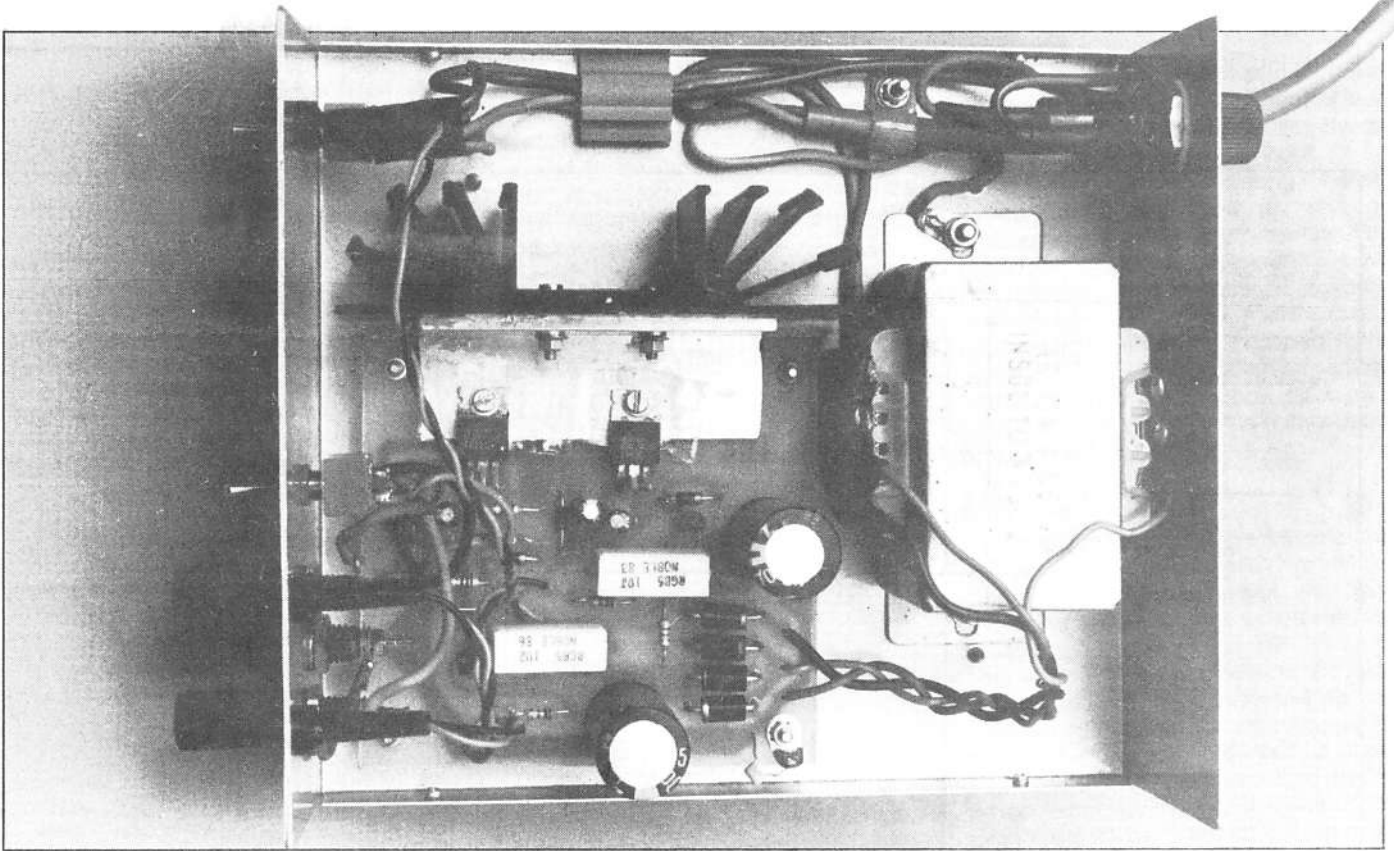

should be made on the pc board with a piece of tinned copper wire (a discarded piece of component lead is ideal). Once this is in position locate and solder in all the resistors. R1 and R2 are high power resistors and in the course of normal operation may get quite hot. To help cooling and to prevent scorching the board these two resistors should be mounted so that they stand off the board by about a millimetre or so. The parts list specifies 1 ohm, 5 watt resistors for R1 and R2 but two 2.2 ohm, 1 watt resistors in parallel can be substituted for each resistor if you wish. There are extra holes on the board to allow for this.

Next, locate and solder in all the capacitors. Take very special note of the way these are put in as they are polarized and may be destroyed rather spectacularly if they are put in the wrong way round. Note that C5 is only soldered to the board at one end. The other lead will be bolted to the pc board mounting bolt at a later stage. For the moment just leave it dangling over the side.

The semiconductors can be soldered next. Start with the diodes. Mount the large rectifier diodes off the board as you did with the power resistors as these too may get hot. Once again pay attention to the way the diodes go in as they are also polarized components.

The two transistors can now be soldered in. The only remaining components to mount are the IC regulators. These will be a bit of a problem in that they mount on an aluminium heatsinking bracket but must be electrically isolated from one another. The first thing to do is to prepare the bracket.

Cut a 70 mm length of 1 inch aluminium

Above: The general layout inside the case. Make sure that the transformer and heatsink are clear of one another.

Right: The mains wiring is run down the left hand side of the box. Try to keep it neat and insulate all connectors on the fuse and switch so that you can't accidentally brush against a live terminal.

angle. Study the photographs and drawings and position the angle at the edge of the board so that it sits between the pc board mounting holes on the component side. The side should point upwards from the board. Use a felt pen or scribe to mark the position of the two mounting holes for the ICs. These holes should be drilled large enough to fit the IC mounting bolts. The heatsink (a 35 mm length of radial fin type) mounts vertically on the side of the aluminium angle. This should be positioned against the angle and the centres for two holes to mount the heatsink should be marked. It is best to drill the holes in the heatsink first and then use these to mark and drill the holes in the angle. This way they'll line up. All the holes in both the bracket and heatsink should be carefully de-burred and the edges made smooth. Thermal conduction to the heatsink is dependent on how well contact is made between the two surfaces. If the edge of the hole is rough it may prevent the two surfaces from contacting each other properly.

To mount the two ICs examine Figure 1 carefully. Position the bracket and lay the ICs on it. Bend the legs of the ICs in the appropriate place and push them through their mounting holes. Take a TO220 package mica mounting washer and thinly coat it on both sides with a layer of thermally conduc-

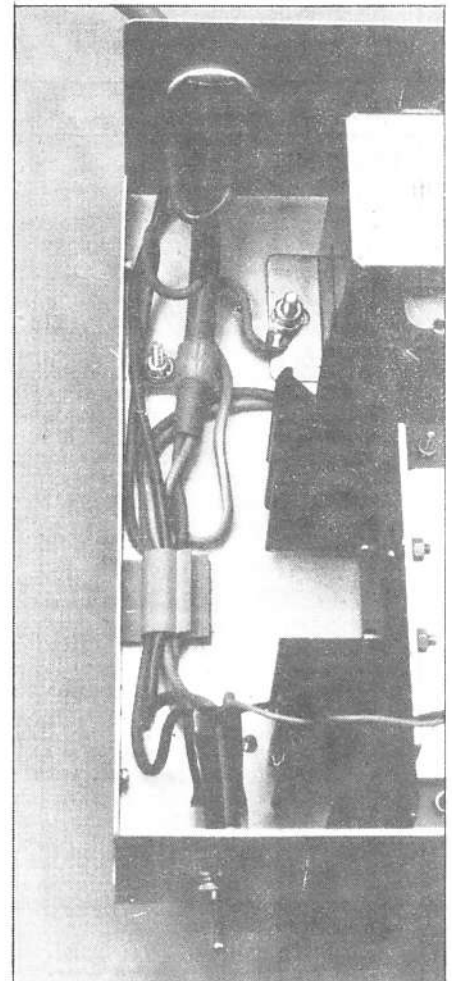

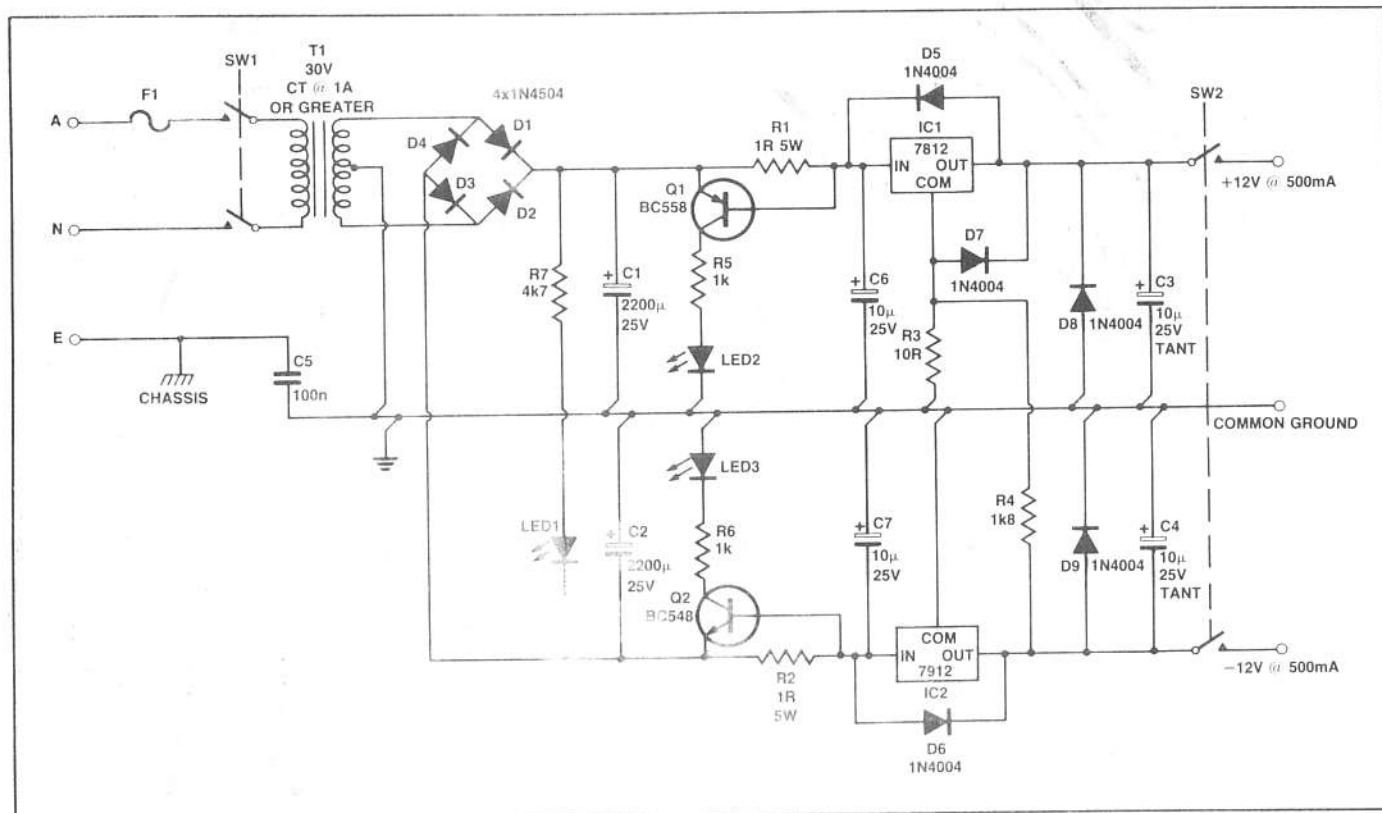

PARTS LIST — ETI-251

Resistors.....all 1/4 W, 5% unless noted

R1, 2.....1R0, 5 watt
R3.....10R
R4.....1k8
R5, 6.....1k
R7.....4k7

Capacitors

C1, 2.....2200 μ , 25 V, RB electro
C3, 4, 6, 7.....10 μ , 25 V tantalum
C5.....100n ceramic bypass

Semiconductors

IC1.....LM7812
IC2.....LM7912
D1, 2, 3, 4.....1N5404
D5, 6, 7, 8, 9.....1N4004
LED1, 2, 3.....5 mm red LED

Miscellaneous

T1.....30 V CT, 1 A sec (Arista type A-6672 or similar)
SW1, 2.....DPDT toggle
F1.....500 mA 2AG fuse

Fuse holder; 185x70x160 mm metal cabinet (DS-H-2744 or similar); mains flex and plug; mains clamping grommet; 3 x 5 mm LED mounting grommets; ETI-251 pc board; Scotchcal front panel; 70 mm length of 1 inch aluminium angle; 2 x TO220 mounting kits (mica washer, insulating washer and nuts and bolts); 3 x 4 mm banana socket binding posts (red, black and green); 35 mm length of radial fin heatsink; heavy duty hookup wire; 4 x 6 mm stand-off pc board spacers; 4 x pc board mounting nuts and bolts; 4 x 15 mm 4BA nuts and bolts; 2 x solder lugs; silicon thermal grease.

Price estimate: \$45-\$50

positive silicon grease. This will ensure good contact from the IC to the bracket. Put the mica washer in place over one of the mounting holes on the bracket and position the hole in the IC over the mounting hole. The bolt and washers can then be put through the hole and tightened up. Note that the bolt is isolated from the metal tab on the IC by a PVC insulating washer specially made for the TO220 package. Repeat the procedure for the other regulator.

To test whether the regulators are isolated from the heatsink, measure the resistance from the centre leg of one IC to the center leg of the other with a multimeter. You should get a high resistance (open circuit) reading. If not then take the ICs off and try again with fresh mica washers. After the ICs have been mounted correctly you can solder the legs to the pc board. The heatsink can now be mounted to the bracket. Use silicon grease to ensure good contact and screw the bolts up fairly tightly.

The next step is to solder flying leads to the input, output and LED mounting points on the pc board. These should be colour coded so you can easily identify the positive, negative or ground when you come to wire the LEDs or terminals. Light hookup wire is adequate for the LEDs but heavier wire (5 amp or more) should be used on the ac input and dc output points. If the pc board is placed temporarily in position in the case, you can get an idea of the length of

wire needed. Always allow a bit more length than you think you'll need as the wire can be trimmed later. Once all the wires are attached the pc board is completed and you can turn your attention to preparing the case.

The prototype was housed in an inexpensive aluminium instrument case (see parts list for details). Take the case apart and don't lose the screws. If you examine the photographs you can get an idea of the general layout of the inside of the case. Looking from the front, the pc board is mounted on the right-hand side at the front. The transformer mounts directly behind this. The mains cord and wiring is all on the left-hand side. Position the transformer and pc board in the box and, after you have ensured that there will be no possible shorting between transformer and the case or the transformer and pc board, mark the positions of the mounting holes for the transformer and board, and drill the holes to fit a 6BA bolt. Holes for the mains cord grommet and the fuse should be marked and drilled in the back panel. If necessary, drill a hole in the floor of the box for a mains cord clamp. To mark out the front panel you can either use the drilling diagram or you can use the front panel artwork as a template and centrepunch the holes from this. Drill the front panel holes to the appropriate sizes. Remove any burrs from the holes and smooth any rough edges.

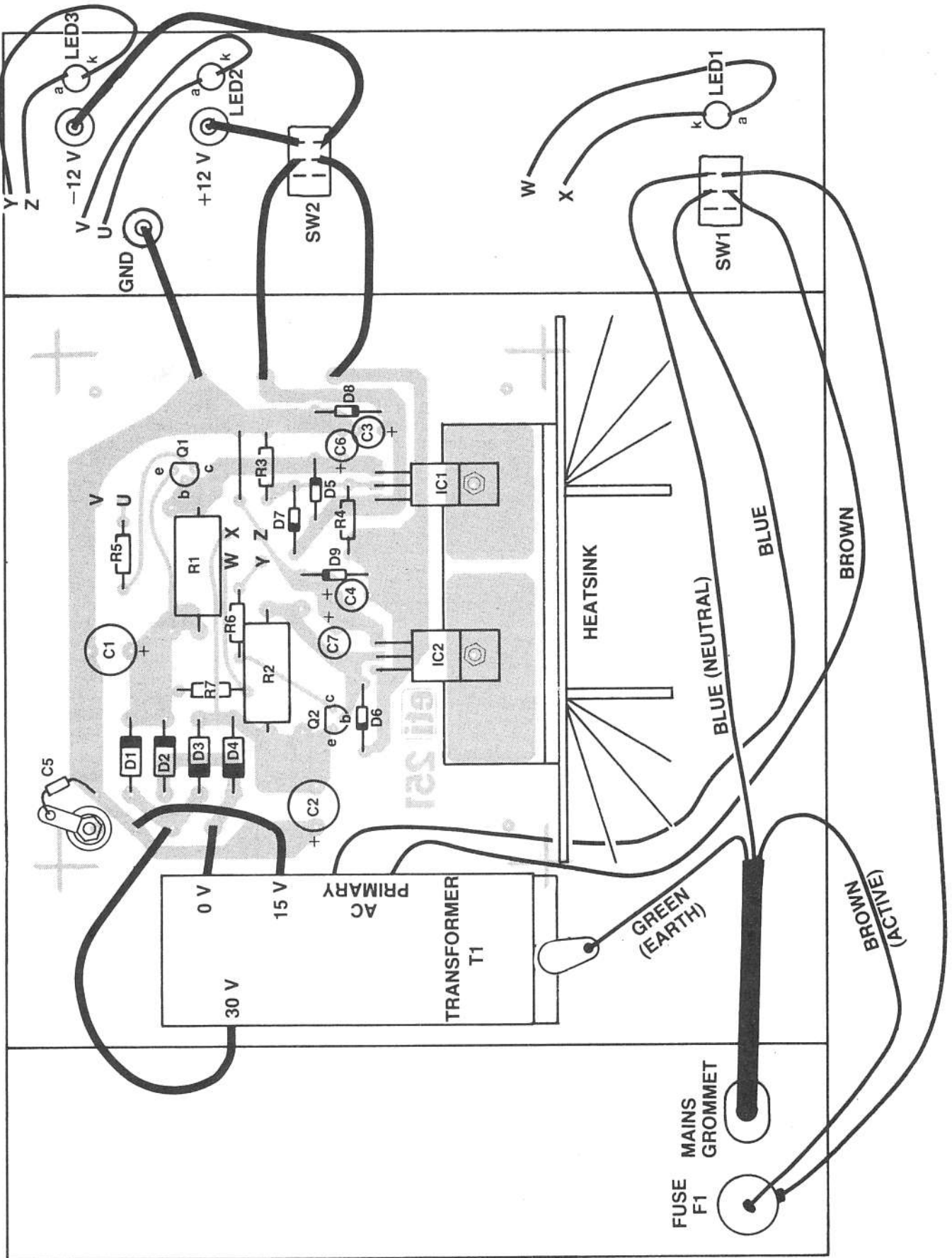

The next step is to attach the Scotchcal label to the front panel if it is needed. Firstly drill small pilot holes at the centres of all the mounting holes. Do a trial fit to see how the pilot holes line up with the holes in the front panel. If they are OK then peel off the backing paper and place the Scotchcal sticky side up on the bench. The front panel can now be carefully positioned above the Scotchcal. Be careful not to touch the Scotchcal as it will stick fast and is hard to get off again. When you are satisfied that the front panel is lined up, carefully lower it onto the Scotchcal and press down. The Scotchcal should now be stuck to the front panel. The holes can be cut out with a sharp knife or scalpel and the edges trimmed. Be careful not to tear the Scotchcal when doing this. Screw on the four rubber feet and the case is now ready.

The next step is to do the mains wiring. Be *very* careful with this as mains voltages are *lethal*. Try to keep all mains wiring neat and tidy and out of the way of everything else. Strip 200 mm of the outer insulation

off a length of mains flex. Thread this through the hole in the back panel and clamp it with a clamping grommet. Make sure it is secure and will not pull out. If necessary use a screw-on mains cord clamp as well. Mount the fuse holder on the back panel and the mains switch on the front panel. Following the wiring diagram carefully, wire up the switch and fuse. All exposed terminals and joins in the mains wiring should be well insulated so that they cannot be accidentally touched. This is best done with heatshrink tubing which is placed over the wire before soldering. When the wire is soldered in place the heatshrink is pushed up over the join till it covers the exposed area. The heatshrink is then heated with a hairdryer or soldering iron and it will shrink to form a tight seal over the join. This should be done for all the connections on the mains switch and fuse holder. As added protection, insulating tape can be wrapped round the entire switch and fuse assemblies.

The transformer should now be mounted

using 4BA nuts and bolts. Note that the earth wire of the mains bolts to the transformer mounting bolt. The earth wire should be long enough to ensure that if the mains cord is pulled out of the box the earth will be the last to break. A solder lug should be soldered on to the end of the earth to ensure that it mounts securely. The transformer primary can now be wired up. Once again heatshrink should be used to insulate the terminals. On the transformer specified the primary connections are at the bottom. This can be a bit awkward to get at so be careful and make very sure that the terminal joins do not short on the floor of the box and are well insulated. This, then, completes the mains wiring. Double check that everything is correct and that no connections are exposed.

The pc board should be mounted next. The mounting bolts should be put through the floor of the box and secured with a nut (see Figure 2). The board then mounts on 6 mm standoff spacers and is bolted down. Solder a lug on the remaining lead on the 100n bypass cap and bolt it to the nearest pc board mounting bolt. The switches, terminal posts and LEDs should now be mounted on the front panel. These can be wired up according to the wiring diagram. When wiring the LEDs be sure to get the wires the correct way round. Finally, the transformer secondary can be wired to the board. A 500 mA fuse should be fitted to the fuse holder and a mains plug (if not already fitted) should be wired to the mains flex (be sure to get the connections right). You are now ready to test the supply out.

Testing and using it

Plug the supply into a mains socket. With the LOAD switch off switch the power on. The power indicator LED should glow and nothing else should happen. With nothing connected to the output terminals, switch the LOAD switch to the ON LINE position. Measure the voltage between the ground and positive terminals. It should read +12 Vdc. Do the same between ground and the negative terminal. It should read -12 Vdc. If this is not the case then unplug, and recheck the wiring and pc board.

If all is well then you can apply a load to the output. Ideally, an 18 ohm, 10 watt power resistor should be wired between the positive terminal and ground. This will draw about 700 mA from the supply and when the supply is turned on with the LOAD switch in the ON LINE position the over-current LED above the +12 V terminal should light. If the load is wired across the negative and ground the LED above the -12 V terminal should light. You can accurately determine the current that the LEDs switch at if you have a high power variable resistor or rheostat. This can be

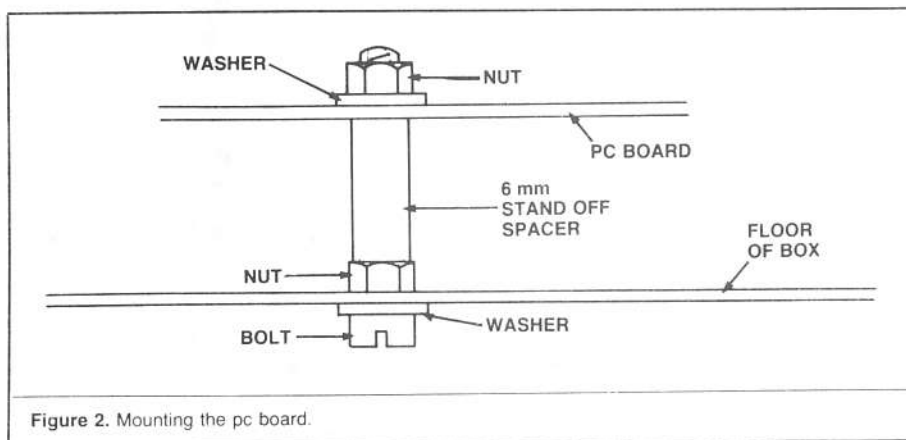
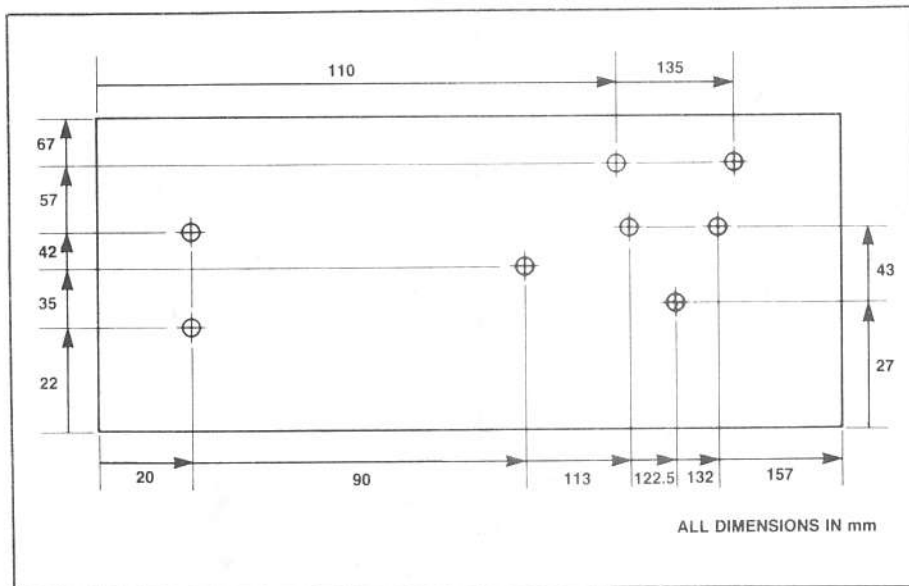
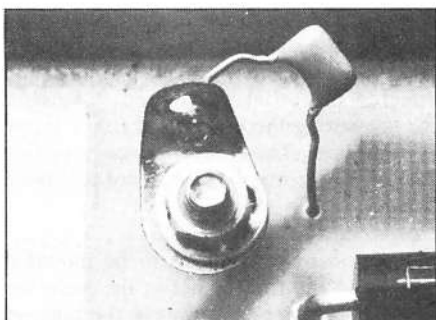
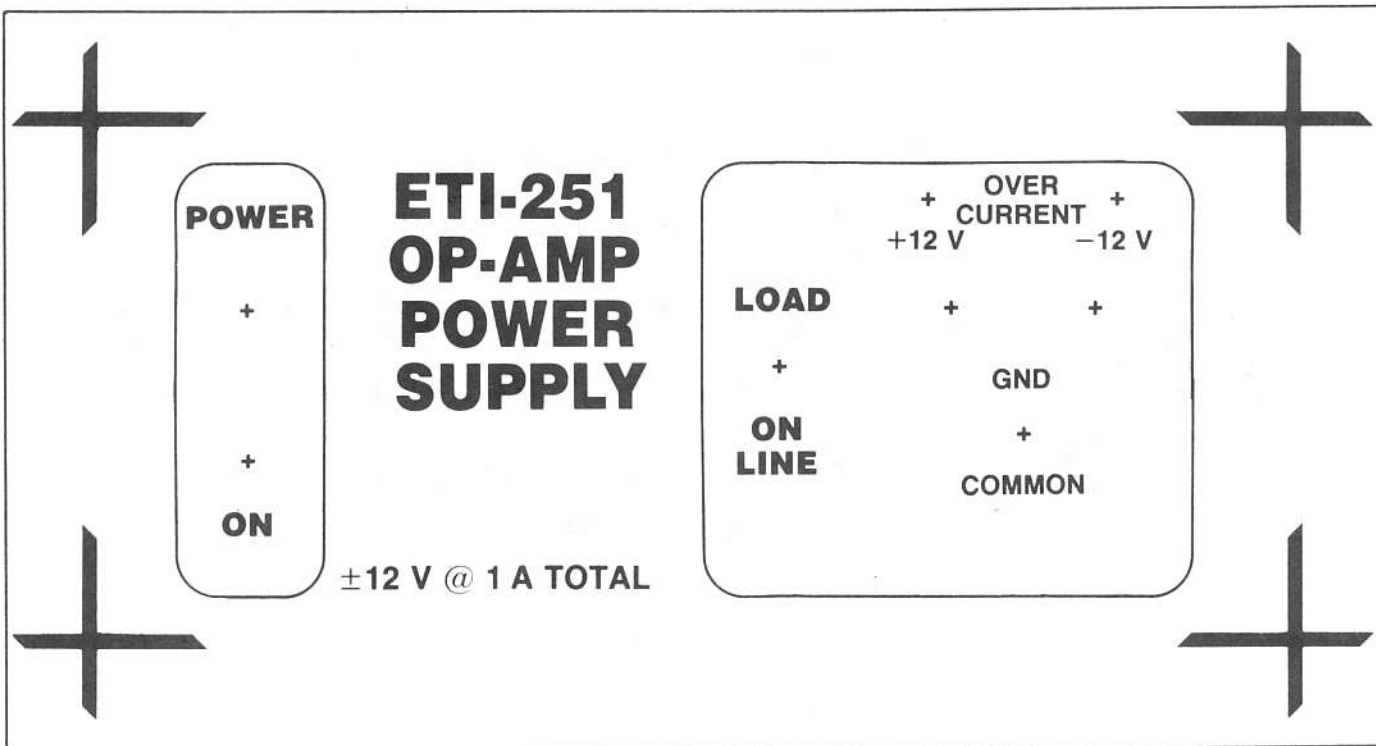

Figure 2. Mounting the pc board.



A solder lug should be used to bolt the 100n bypass cap to the chassis. This allows the case to act as an rf shield but still provides for a floating supply.

varied until the LED just lights. The resistance can then be measured and the current determined.

If the supply tests out OK so far, then connect a piece of heavy duty hookup wire between the positive and ground, and switch on. The supply should power up with the +12 V overcurrent LED lit. Do the same for the negative terminal. Finally, do the same thing with a piece of wire between the positive and negative terminals. Both LEDs should light this time. If all is well then switch off, unplug and put the lid back on. You are now ready to use the supply.

The only thing on the front panel that may require a few words is the LOAD switch. This merely disconnects the output terminals from the supply. This was done so that on power up and power down the load can be disconnected from the supply and thus be unaffected by any transients when the regulators power up or down. This is particularly useful when making changes to a breadboard for instance. If the main

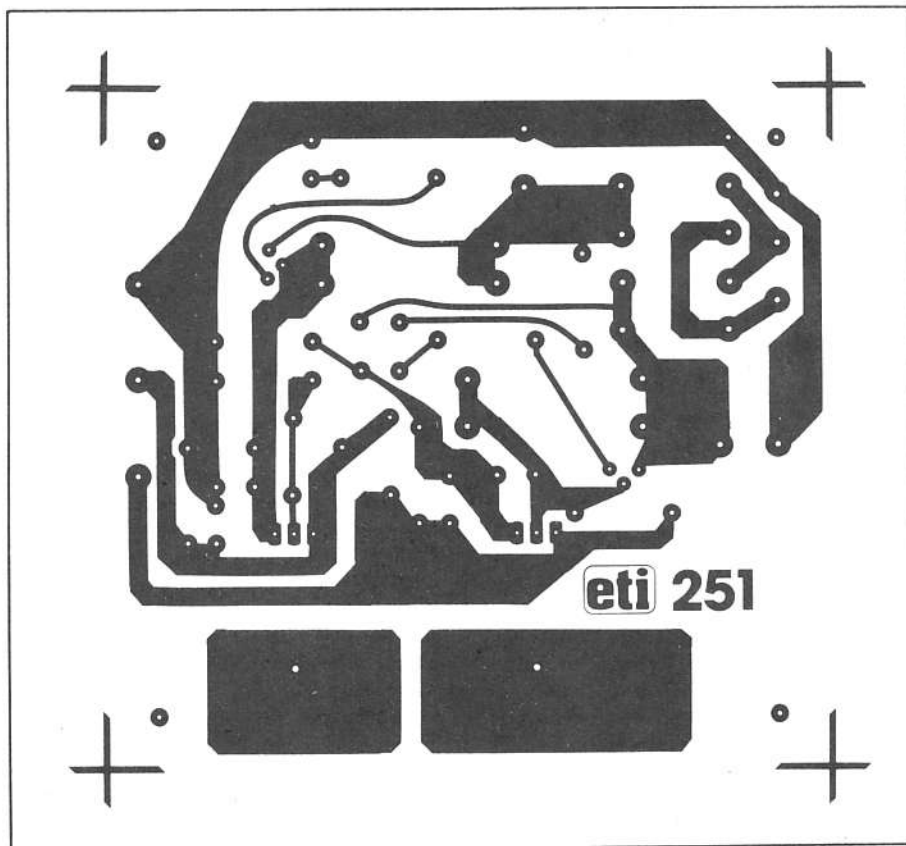

power switch were used to turn the supply off then you would have to wait a couple of seconds for the capacitors to discharge and the voltage to go to zero before altering the circuit. Using the LOAD switch, the circuit is instantly disconnected from the supply.

If you are powering a circuit and the

overload LED comes on you should switch off. Although the supply can maintain overloads for quite long periods it is wise not to run the supply continuously in this mode as thermal stressing of the components can occur which may eventually lead to failure.