

Logic circuit tests wiring assemblies

by Steven Graham
Parsippany, N. J.

Before shipment or installation of wiring harnesses, the completed assemblies must be checked to verify that each pin of the connector at one end is wired to the corresponding pin of the connector at the other end. Open circuits, short circuits, and crossed wires can quickly be detected and identified by a testing circuit consisting of a pulse generator, a shift register, some gates, and light-emitting diodes. This circuit, shown in Fig. 1, provides an inexpensive and effective replacement for stepping switches, ohmmeters, and expensive analyzers.

To check a wiring assembly, the test-station operator plugs the two connectors into the test fixture, presses the CLEAR button if any of the LEDs is on initially, and then presses the START button. If the harness has been wired correctly, the LEDs turn on and off sequentially. Crossed

wires are indicated when the LEDs come on out of sequence. A short circuit causes two LEDs to light simultaneously. An open circuit turns the LED on as soon as the harness is connected.

The circuit diagram shows that the 555 timer is connected as a free-running multivibrator with a frequency of a few hertz. The pulse train from the 555 clocks the flip-flops to shift the high starting pulse down the line, feeding a high input to each NAND gate sequentially.

If a wire in the harness is not connected, so that the input to a NAND gate is not connected to its flip-flop, that gate stays high all the time (even when the CLEAR button is pushed), and the LED stays on. If the wire bundle contains N wires, then N flip-flops and N LEDs are required. The 1-microfarad capacitor and the two resistors connected to the 555 may be changed to increase or decrease the test rate.

This circuit has been used for more than a year to check 12-wire jumper harnesses. It could be refined so that the LEDs turn on sequentially and stay on if the wiring is correct, and a latch could halt the sequential shift when a fault is located. The operator could do other things while the test proceeded; this improvement would be especially useful for many-wire harnesses. □

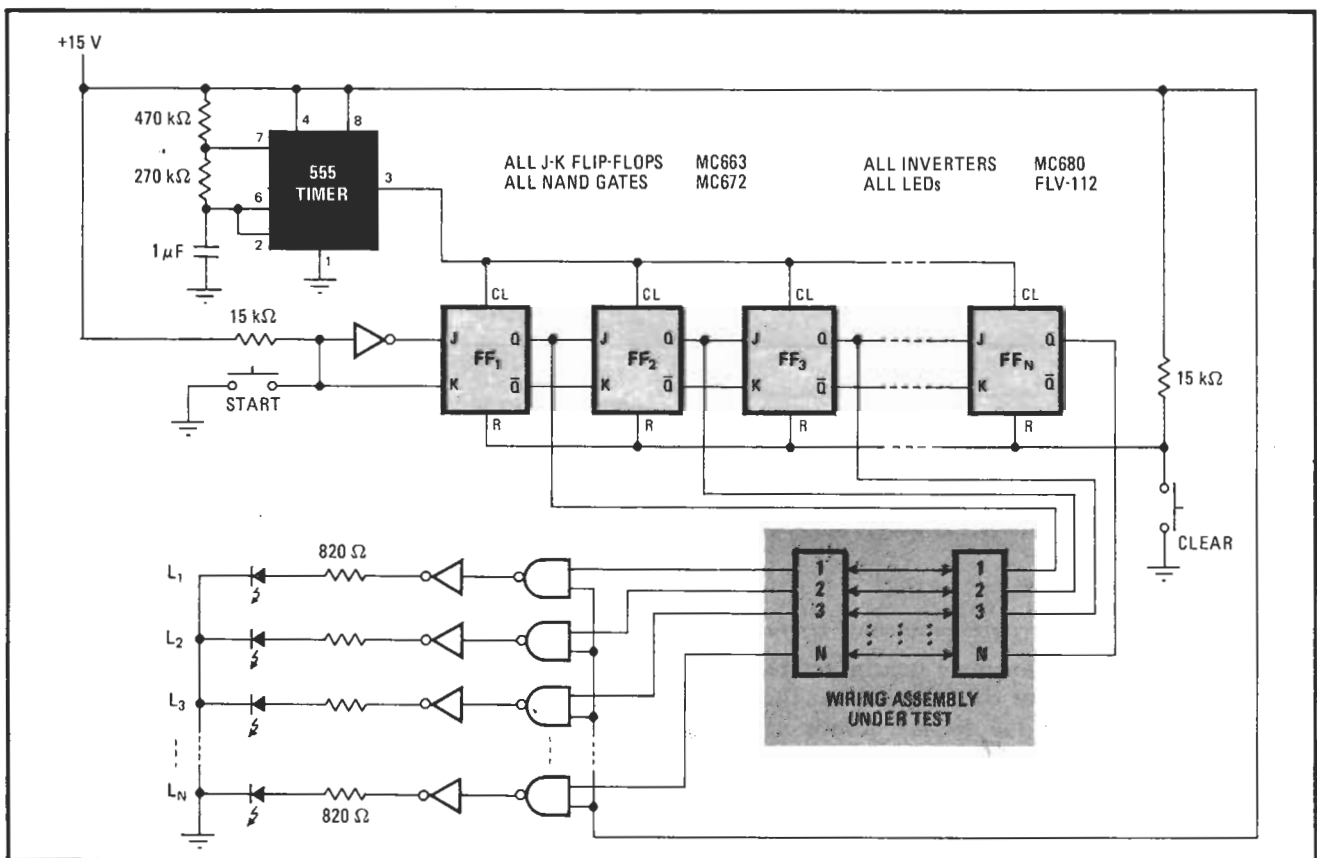

Flashing the word. Test arrangement checks feed-through wiring between two connectors on harness of N wires. Correct continuity is indicated by LEDs flashing on and off sequentially. Crossed wires cause LEDs to flash out of sequence, a short circuit makes two LEDs flash simultaneously, and an open causes a LED to glow continuously. Although high-threshold-logic elements are shown, TTL is satisfactory.