

# A Simple Impedance Bridge

*This two-component project lets you measure impedance, determine resonant frequency, calculate input/output impedance ratios, etc.*

By William R. Hoffman

**A**nyone involved in loudspeaker design and construction soon finds the impedance bridge to be an important basic tool in his work. Despite its current un-

popularity, the impedance bridge is probably the most versatile piece of test equipment you have to make reactive (inductive and capacitive) measurements.

You have only to consider the range of uses for the impedance bridge to realize its value. With the

bridge, you can quickly measure the impedance of an unknown capacitor or inductor at a given frequency and then go on to find the resonant frequency of a loudspeaker. You can also measure the impedances of a transformer's windings and then calculate its input/output impedance





ratio. Analyzing a complex load, such as presented by a distributed line or a multiple-speaker PA system, is a relative snap. Actually, the list of uses can go on and on.

Now that you know the value of the impedance bridge, you can build one of your own. All it takes is a resistor and a switch, plus a signal generator and an ac voltmeter. Though the impedance bridge setup to be described is utterly simple, one exactly like it is regularly used by a well-known hi-fi equipment reviewer for his published test reports.

### About the Circuit

Shown in Fig. 1 is the schematic diagram of the impedance bridge. Since it contains only a resistor ( $R1$ ) and a double-pole, double-throw switch

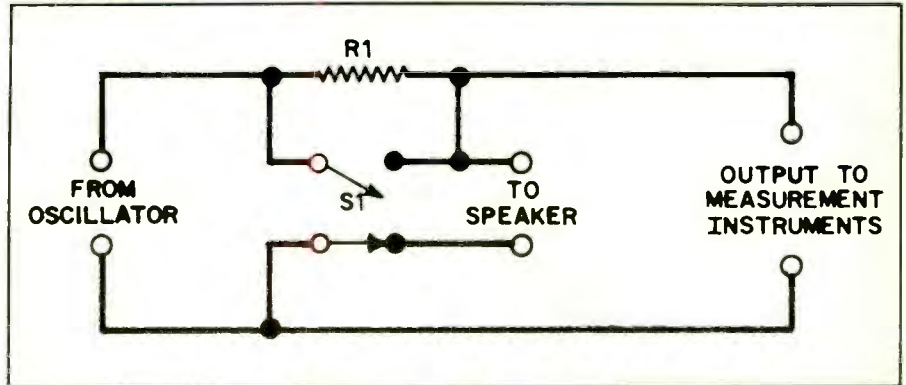

Fig. 1. This is the schematic diagram of the impedance bridge. This two-component circuit must be used with at least an oscillator and an ac voltmeter.

( $ST$ ) this circuit is more in the “accessory” rather than “instrument” category. To be useful at all, it must be connected to a signal generator and a voltmeter (or chart recorder or oscilloscope) as detailed in Fig. 2.

In this circuit,  $R1$  makes the ac voltage from the oscillator appear as a constant current. (The only limiting factor in this arrangement is the oscillator, which can be narrow or broad spectrum, depending on your specific applications.) Therefore, the voltage dropped across the device under test (D.U.T. in Fig. 2) is simply a direct indication of its impedance. When the bridge is calibrated, each ohm of impedance is equal to 1 millivolt at the accessory’s output. This greatly simplifies matters, since the measured voltage on the meter (on a millivolt scale) can be directly read as impedance. For example a reading of 2.7 mV becomes 2.7 ohms, while 32 mV becomes 32 ohms.

If your voltmeter lacks adequate sensitivity to accurately respond to signal amplitudes in the millivolt range, you can simply run the oscillator’s output through an amplifier to obtain the required signal boost to obtain useable readings. If you do this, note in Fig. 2 that the amplifier connects in *series* with the oscillator and bridge, as indicated by the “X” through the feed line. If you know the amplifier’s gain, you can use this figure in any calculations. If the gain

is not known, you can place a resistor of known value across the measuring terminals of the bridge and calibrate from that.

Note in Fig. 1 that no value is specified for  $R1$ . This is because the value used will depend on the output signal amplitude from your signal generator. To determine what value resistor you need, refer to the Table. The first column of the Table lists typical oscillator output levels in peak-to-peak (p-p) voltage. Column two tells you what resistor value is needed at each output level. By the rules, then, if your generator outputs a 1-volt peak-to-peak signal, the value of  $R1$  should be 1000 ohms; for a 2.4-volt output,  $R1$  would be 2400 ohms; and so on.

Columns three, four and five of the Table tell you the maximum impedance that can be measured for each oscillator-output/resistor-value combination at 1%, 5% and 10% bridge error, respectively.

Notice that to measure impedances of several hundred or more ohms, an oscillator with greater signal output level and a higher value resistor are needed. If you want to measure higher impedance, then, your oscillator’s output will usually have to be boosted with an amplifier capable of reaching the required level and use a higher value of resistance for  $R1$ . It is not necessary for the amplifier to have an especially low level of distort-

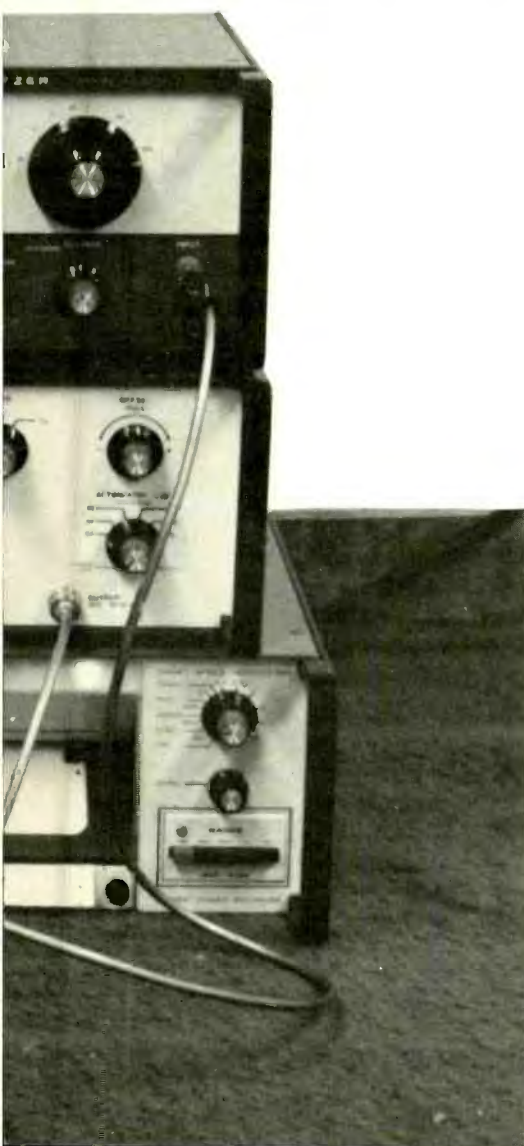



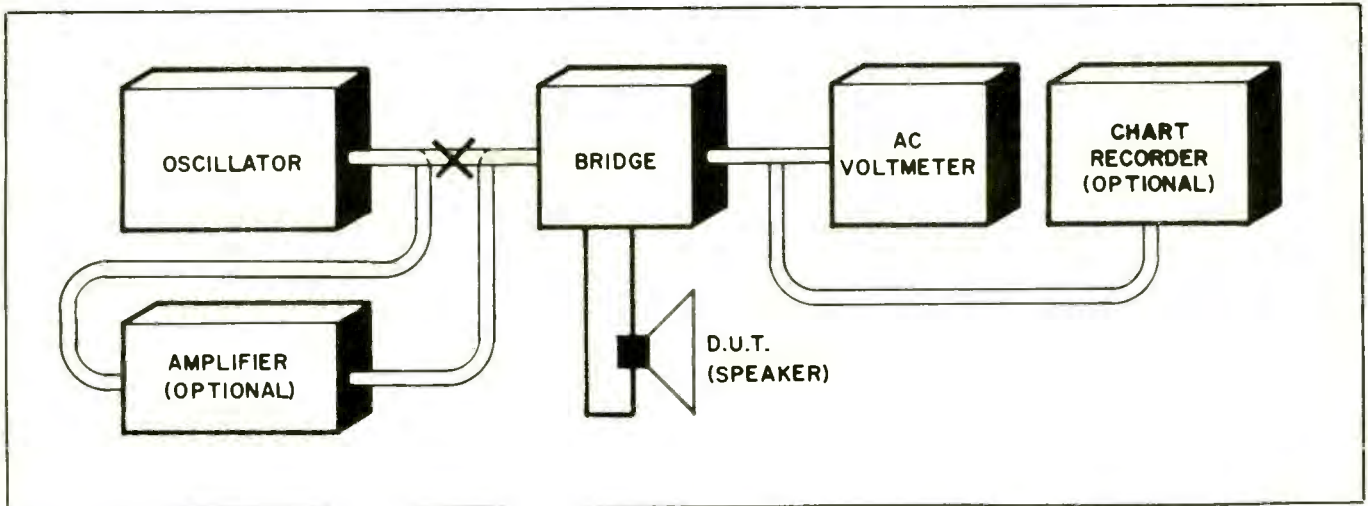

Fig. 2. A typical test setup. Required items are the bridge, oscillator and ac voltmeter. The amplifier and chart recorder are optional. If you wish, you can connect a dual-trace oscilloscope as explained in the text.

tion or a very wide range to obtain adequate measurements from the impedance bridge arrangement.

The impedance bridge is best built into a metal or plastic box. For my prototype, I chose a common sloping top instrument box, with *SI* located in the middle of the sloping panel and the input and output connectors flanking the switch as shown in the lead photo. With this setup, *R1* mounts directly on the appropriate lugs of the switch, and the connections to the D.U.T. were brought out from the appropriate points in the circuit, via a cable, through the front wall of the box. The connectors on the top of the box are all 5-way binding posts, and the D.U.T. cable is terminated in miniature alligator clips. Once the bridge was assembled, I labeled the panel with a tape labeler.

### Setup and Use

Figure 2 details the various instruments (including options) that are used with the bridge and the proper connections to be made. Every time you use the bridge, you must set up the system as follows:

(1) Turn on all connected test equipment. If you are using a digital or analog multimeter, set its function selector to ac volts.

(2) Set *SI* to the position that

Oscillator Output (volts)	Value of <i>R1</i> (ohms, 2% tolerance)	Maximum measurement range (ohms)		
		1% error	5% error	10% error
1	1000	10	50	100
2.4	2400	24	120	240
5	5000	50	250	500
10	10,000	100	500	1000

shorts out *R1* and opens the line to the D.U.T. This connects the voltmeter directly to the bridge's output and removes from the measurement any device under test.

(3) Set the oscillator's level or am-

plitude control for the correct voltage reading on the voltmeter according to the value selected for *R1*.

(4) Set *SI* to its alternate position

(Continued on page 84) ▶

Fig. 3. Shown here are impedance-versus-frequency plots for typical full-range, two-way and three-way speaker systems. Note resonance peaks on each curve.

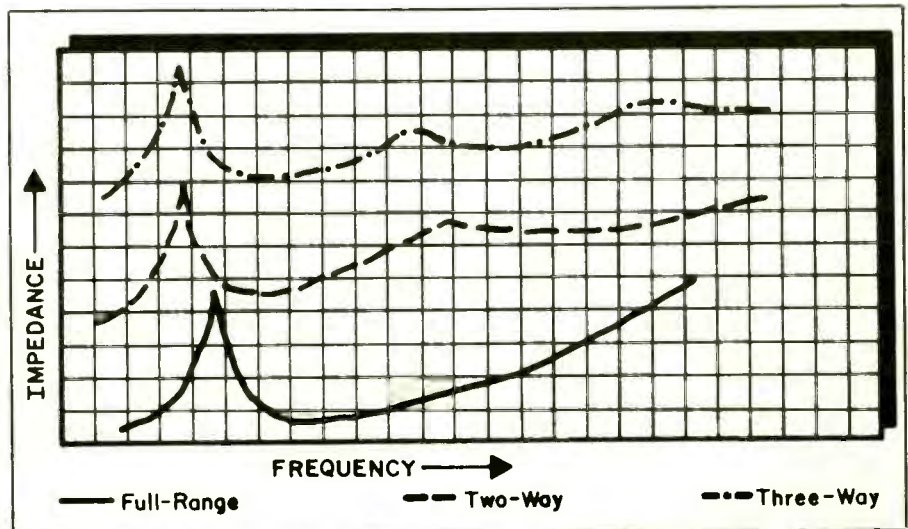

## Impedance Bridge *(from p*

( $R/$  in the circuit and the line to the D.U.T. closed). At this point, you should have nothing connected to the D.U.T. cable. Set the voltmeter's range selector for making measurements in the low millivolt range.

(5) Connect the component to be tested to the D.U.T. (speaker) cable and read the impedance directly from the meter's display.

The system is very simple to set up and use. You can make impedance measurements at any frequency within the oscillator's or meter's range (whichever is the lowest), without having to recalibrate the system. (Most oscillators nowadays have a constant output voltage that does not vary with frequency.)

Figure 3 shows a typical set of impedance-versus-frequency curves for full-range, two-way and three-way speaker systems. The left-most peak on each curve is the systems' free-air resonances. This peak usually has a value of 25 to 70 ohms. Lowest impedance is usually measured just to the right of the resonance peak and may be as low as 3 to 5 ohms. The exception to the curves illustrated in Fig. 3 is the case of the bass-reflex system, where the single resonance peak will be absent, usually replaced by two smaller peaks.

Checking capacitors and inductors (the latter including transformers) is as easy as observing the impedance trend of the readings on the meter's display as the frequency of the oscillator is varied. Any good capacitor will show an impedance that constantly decreases as the frequency is increased. With a good inductor, on the other hand, impedance will increase as the frequency is increased. You can use your measurements to check the value of a component, too, simply by plugging the known frequency and measured impedance into the appropriate reactance formula and solving for the unknown value.

One more function that the bridge can perform should prove of value to you. That is the ability to indicate

phase angle, a parameter associated with the reactance of the component being tested. As you may recall, voltage leads current in an inductor, while voltage lags current in a capacitor. To read phase angle, simply connect the output from the bridge to the channel 2 input of a two-channel oscilloscope and the output from the oscillator to the channel 1 input. You will then observe that the two traces on the scope's screen are offset (not in vertical alignment with each other). This offset is the phase angle.

For a component that is predomi-

nantly capacitive, the trace for the output from the bridge will be lagging the trace for the output from the oscillator. This condition will be just the opposite for an inductor.

With all we have said about the impedance bridge, we have not begun to scratch the surface in telling you how useful this "instrument" can be on your testbench. However, we hope that what has been written here will induce you to at least give the impedance bridge a try. Once you do, you are almost certain to find uses for it we have not mentioned. **ME**