

EDITED BY BILL TRAVIS & ANNE WATSON SWAGER

25-kV generator tests insulation

LUKASZ ŚLIWCZYŃSKI AND PRZEMYSŁAW KREHLIK, UNIVERSITY OF MINING AND METALLURGY, KRAKÓW, POLAND

To generate high voltages with proper insulation between the “hot node” and the rest of the circuitry, a car ignition coil can function in place of a high-voltage transformer. These coils have voltage ratings of approximately 20 kV, so you can use them to produce voltages around this value. Because you know the turns ratio of the coil, you can make a stable high-voltage source using a well-controlled voltage at the primary side (**Figure 1**).

A high-voltage source is a useful device for many applications, including when it is necessary to evaluate the continuity of the dielectric coating deposited on a metal surface. If you also want to estimate the breakdown strength of the coating, this voltage source must be stable. You can easily generate the high voltage with the use of a step-up transformer, but the serious problem of proper insulation emerges. For voltages greater than a few kilovolts, specially construct-

ed transformers with the old insulation are often useful, but these devices are rather expensive and bulky.

The main part of the generator in **Figure 1** consists of a free-running converter comprising Q_1 , Q_6 , and the transformer, T_1 . During the first part of the conversion cycle, Q_1 is saturated, and energy stores in the magnetic field of T_1 . D_1 is reverse-biased during this time. In the second part of the cycle, Q_1 is in cutoff, and the current from the secondary winding of T_1 forces D_1 into conduction. During this time, energy pumps into C_1 through part of the ignition coil, T_2 . This process allows the voltage, V_{C1} , on C_1 to build gradually in a quantized manner. The value of the individual “quantum,” ΔV_{C1} , is not constant and depends on the initial voltage, V_{CO} , which comes from the previous cycle, as follows: where

is the energy stored in the magnetic field of T_1 in the first cycle

FIGURE 1

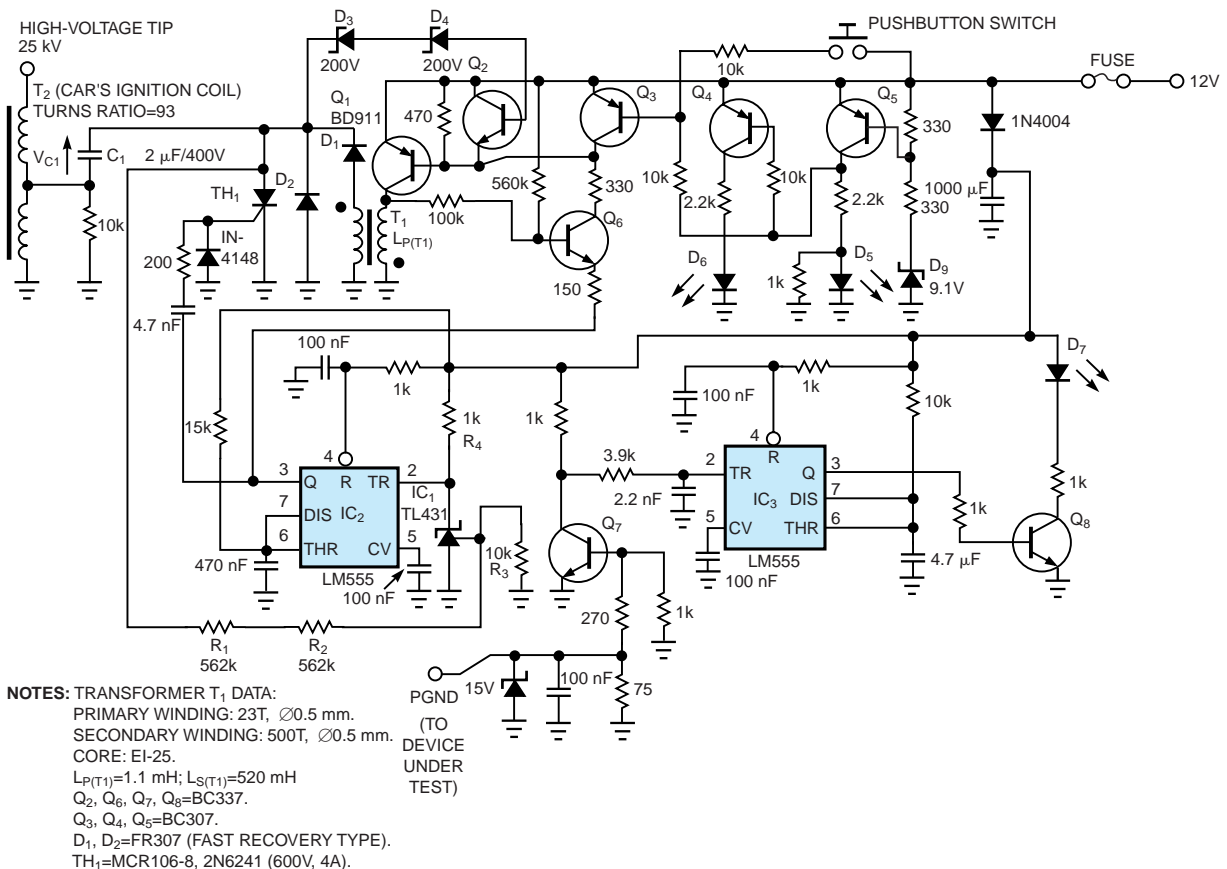

Using a car's ignition coil produces a test voltage as high as 25 kV for insulation testing.

and $I_{C_{MAX}(Q1)}$ is the collector current of Q_1 at the end of the first cycle. For the component values in **Figure 1**, $\Delta E_C \approx 0.5$

$$\Delta V_{C1} = V_{C0} \left(\sqrt{1 + \frac{2\Delta E_C}{V_{C0}^2 \cdot C_1}} - 1 \right) \approx \frac{\Delta E_C}{V_{C0} \cdot C_1},$$

$$\Delta E_C = \frac{L_{P(T1)} \cdot I_{C_{MAX}(Q1)}^2}{2}$$

mJ, and $I_{C_{MAX}(Q1)} \approx 1A$.

R_1 , R_2 , and R_3 divide down V_{C1} . When this reduced voltage reaches 2.5V, the TL431's 2.5V reference starts to sink the current through R_4 , so the voltage at the trigger input of the one-shot, IC_2 , rapidly decreases. An output pulse from IC_2 stops the converter for about 8 msec; the emitter node of Q_6 goes high, driving it into cutoff. The rising edge of IC_2 's output pulse also triggers thyristor TH_1 . The thyristor connects C_1 , which is charged to the appropriate voltage, directly to the primary winding of the ignition coil, and the high-voltage pulse appears at the "hot" end of the coil. A damped oscillation also starts because the ignition coil and C_1 form a resonant circuit.

When a path between the "hot" end and ground exists, part of the energy from the capacitor disperses in the electric arc, and the rest returns to the capacitor through D_2 . When there is no path from this end of the current to flow, almost all of the energy pumps back into C_1 . This scheme provides the circuit with relatively high efficiency.

You can calculate the voltage at the "hot" side using the following formula:

where $N_{SEC(T2)}/N_{PRI(T2)}$ is the turns ratio of the ignition coil, which equals 93 in this case. Changing the value of R_3 conveniently regulates V_{HIGH} . The accuracy of this voltage is in

$$V_{HIGH} = 2.5 \left[1 + \frac{R_1 + R_2}{R_3} \right] \left[1 + \frac{N_{SEC(T2)}}{N_{PRI(T2)}} \right],$$

the range of one "quantum" ΔV_{C1} multiplied by T_2 's turns

ratio. Thus, ΔV_{C1} should be small to achieve good stabilization. On the other hand, a smaller value increases the time between subsequent high-voltage pulses. In this case, the accuracy estimate of the high-voltage pulse is better than 0.5% at 25 kV.

The free-running frequency of the converter depends on the time it takes to lead Q_1 out of saturation (first part of the cycle) and the time when the current from the secondary winding of T_1 drops to a value near zero (second part of the cycle). This circuit doesn't tightly control this frequency, which isn't a critical design parameter; the values in **Figure 1** set the frequency to approximately 6 kHz.

Q_2 , D_3 , and D_4 prevent V_{C1} from exceeding about 400V, which protects the generator from producing excessively high voltages. Q_3 , Q_4 , Q_5 , and associated circuitry allow for blocking the converter when the power supply to the circuit is too low. A too-low power-supply level may lead to an output-pulse amplitude from IC_2 that is too low to trigger the thyristor, so V_{C1} may reach a very high value, limited only by the breakdown voltage of the thyristor. This breakdown voltage is the second level of protection, but you can never take too much care in circuits like these.

Two LEDs indicate the status of the power supply: D_5 indicates that the level is OK, and D_6 , that the power supply is too low. One-shot IC_3 , Q_4 , and associated components form the source of an alarm, indicated by a flashing D_7 , when the isolation breaks down or a discontinuity occurs. A simple push-button switch turns on the generator.

For the component values in **Figure 1**, the circuit generates 25-kV pulses with a repetition rate of approximately 0.2 sec. This repetition rate depends on the occurrence or lack of occurrence of the electric arc. Because the amount of energy stored in C_1 is relatively low, the energy of the high-voltage pulse is also low, which is good for safety purposes. Note that it is very important and absolutely necessary to connect the part you're testing to the PGND point, because the risk of electric shock exists. (DI #2199) e