

# A LOW-COST DOT / BAR GENERATOR

**A** DOT/BAR video signal generator is an essential piece of test equipment for the setup and convergence of a color-TV receiver or monitor. The generator can also be used to adjust horizontal and vertical linearity of monochrome receivers and monitors.

The circuit (Fig. 1) shown here can be built for about \$15, and is small enough to be permanently installed in a color-TV cabinet. It can also be housed in a small case (including a 9-volt battery) for portable use. Since the output is video, some form of FCC-approved r-f modulator is required if you wish to inject the signal into the antenna of a TV receiver.

**Circuit Operation.** Oscillator *IC1* is preset to 251,752 Hz (16 times the horizontal scanning rate) by the setting of potentiometer *R1*. When a 555 is operated with *D17* as shown, the data sheet formulas for frequency are not valid, and the frequency of oscillations becomes more dependent on the supply voltage. The output of *IC1* (pin 3), drives 12-stage counter *IC2* to generate the other frequencies required to create the composite video output signal. Various *IC2* outputs are diode OR'ed to produce the proper pulse widths.

Horizontal and vertical video components are combined in NOR gate *IC3A*, while the horizontal and vertical sync components are mixed in *IC3B*. Output transistors *Q1* and *Q2*, arranged as an AND gate, combine video and sync into

composite video and provide sufficient drive for a 75-ohm output load.

With *S1* in its center (off) position, the video display will be white dots on a black background. The other positions of *S1* yield horizontal or vertical white bars on a black field. These are the output signals most commonly used for static and dynamic convergence of color receivers. They can also be used to set linearity of monochrome receivers.

The values of *R9* and *R10* determine the base currents of *Q1* or *Q2*, and their connections to *IC3* determine positive or negative video. Resistor *R11* determines the blanking (black) level of the display. Resistor *R12* determines the peak-to-peak output voltage level, while *R13* determines the output impedance.

When powered by 9 volts, the values shown for *R9* through *R13* provide a nominal one volt peak-to-peak composite video with negative-going sync into a 75-ohm load.

If *R9* is disconnected, the unit becomes a sync generator. Increasing the value of *R3* (retuning *R1*) will increase the width of the bars or dots. Eliminating *D9* will increase the height of the bars or dots.

**Construction.** The circuit can be assembled using any type of wiring technique; the foil pattern shown in Fig. 2 may be used. This illustration also shows component installation.

With the generator powered and *S1* in

*Build this essential instrument for setup and convergence of color TV for \$15.*

## PARTS LIST

- C1—100-pF, disc ceramic
- C2—0.1- $\mu$ F, disc ceramic
- C3—220- $\mu$ F, 35-volt electrolytic (optional)
- D1 through D17—1N914 silicon diode
- IC1—555 timer
- IC2—CD4040, 12-stage ripple counter (CMOS)
- IC3—CD4001, quad 2-input NOR gate (CMOS)
- Q1, Q2—2N5449 npn silicon transistor
- The following resistors are 1/4-watt, 10%:
- R2—10,000 ohms
- R3, R13—75 ohms
- R4, R11—2200 ohms
- R5, R6, R7—100,000 ohms
- R8—27,000 ohms
- R9, R10—1000 ohms
- R12—470 ohms
- R1—10,000-ohm trimmer potentiometer
- S1—Spdt, center-off switch
- Misc.—battery holder, suitable enclosure, interconnect cable, mounting hardware, etc.

Note—A complete kit of parts including drilled pc board, is available for \$14.95 plus \$1.50 P+H within the continental US from ABCOR Inc., Box 58216, Houston, TX 77058. Texas residents, please add 5% sales tax. The r-f modulator is available from ABCOR, or M&R Enterprises, PO Box 1011, Sunnyvale, CA 94088 for \$24.95 with 60-dB isolation switch and cables. Modulator only is \$14.95.

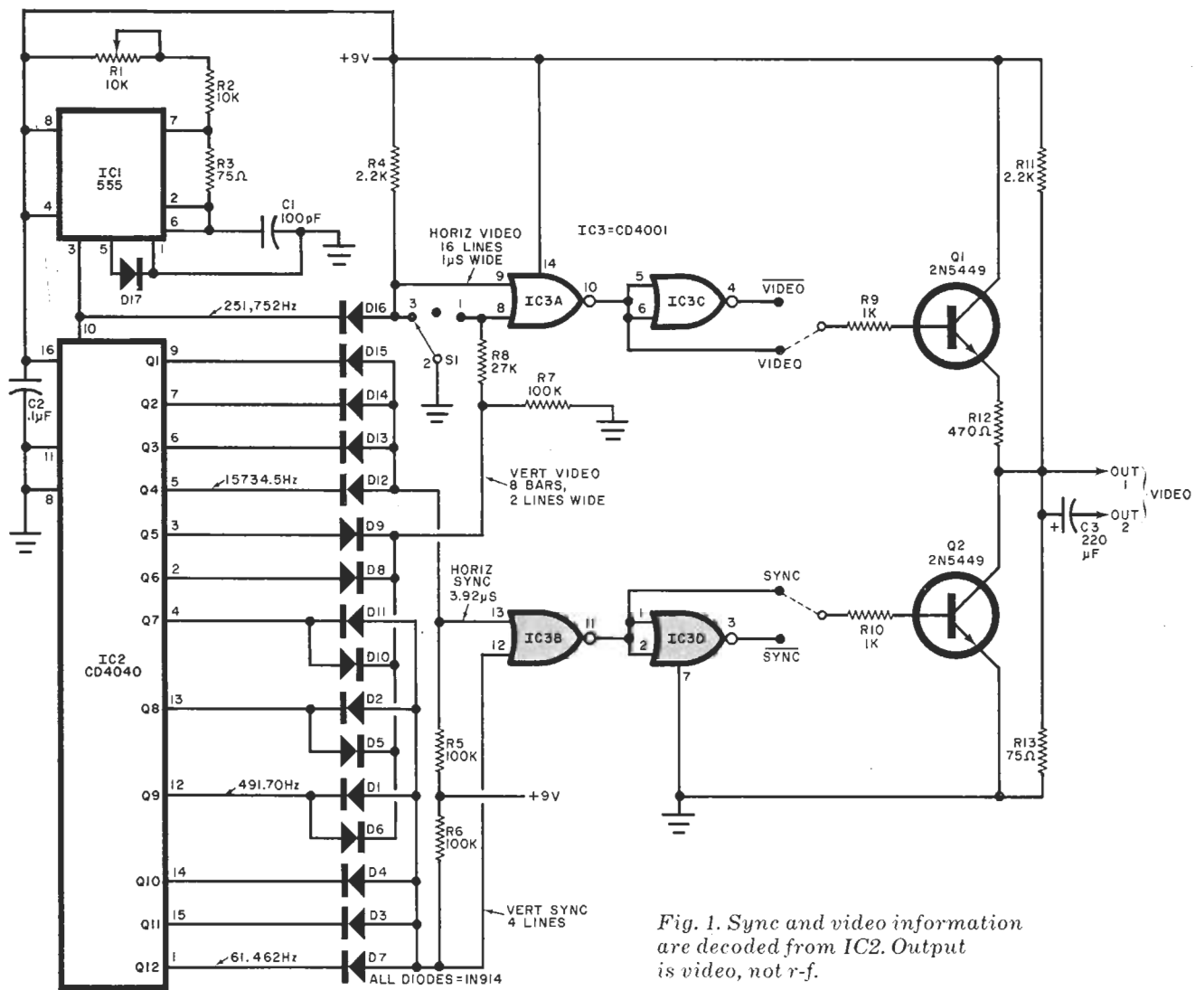

Fig. 1. Sync and video information are decoded from IC2. Output is video, not r-f.

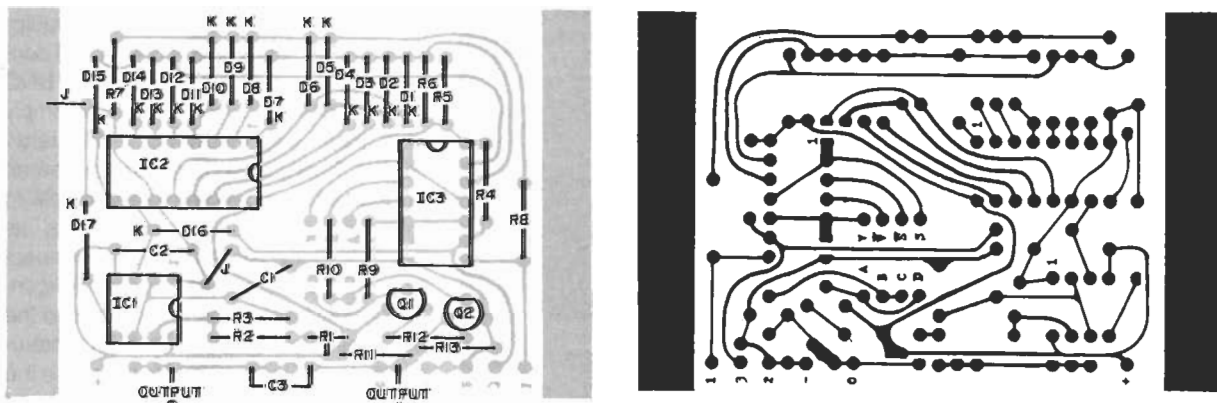

Fig 2. Actual-size foil pattern and component installation for the generator. The two large end bars are used for mounting, and are not required for operation.

the center position, connect the generator to the video input of the receiver to be checked, and turn on the power. Adjust R1 until the sync locks and a stable pattern appears on the screen.

With the manual provided by the color-TV receiver manufacturer or other source, the generator can now be used for convergence. In a monochrome system, the bars or dots can be used in con-

junction with the linearity controls to set up the screen for proper proportions.

Two video outputs are provided: One (out 1) is dc coupled to the output stage, while the other (out 2) is dc isolated from the output stage. Use either one, depending on the type of input required. If the video stage will not tolerate a dc offset, then use output 2. If the video stage has capacitor input, use output 1. ◇