

The NE602 could very well become the RF experimenter's "555" chip. Learn about this fascinating and versatile device for your next RF project.

# USING THE NE602

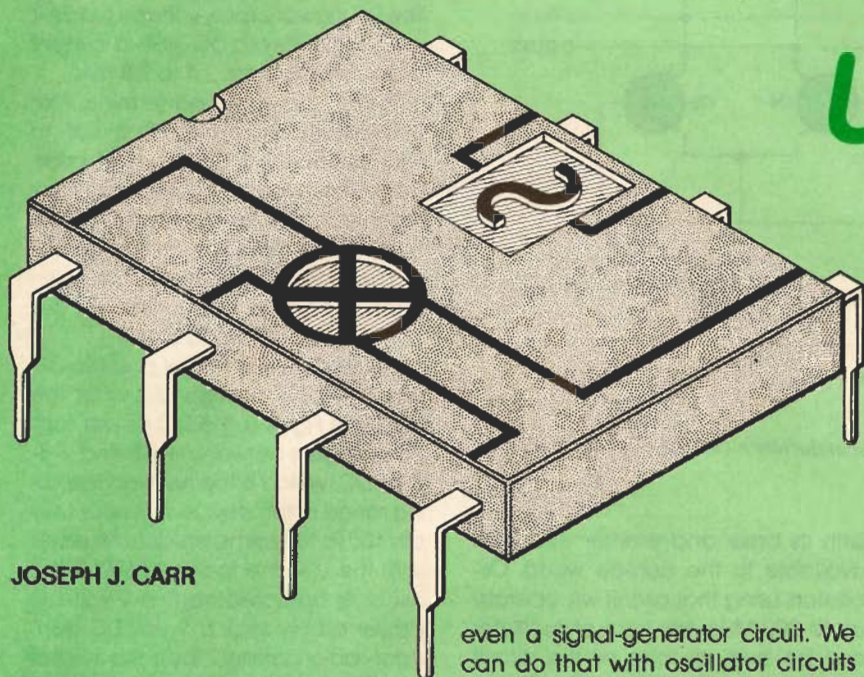

JOSEPH J. CARR

Every now and then a chip comes along that strikes the public imagination, so it gets used in a lot of projects. The 741 operational amplifier was like that in the early 1970s. Also reaching a high pitch of popularity was the 555 IC timer chip. Both of those chips reached such heights because they were both useful and well-behaved (i.e. they did what they did with little fuss or fuss). The radio frequency (RF) hobbyist, however, only recently found a chip that meets those requirements: the NE602 from Signetics.

The NE602 device is a monolithic integrated circuit containing a double-balanced mixer (DBM) and an internal oscillator circuit. The DBM has balanced inputs (pins 1 and 2), balanced outputs (pins 4 and 5), and can operate at up to 500 MHz. The internal oscillator circuit provides an emitter connection and a base connection to the outside world. Figure 1-a shows the block diagram, and Fig. 1-b the pinouts for the NE602 device.

The NE602 is meant to be used as the receiver front-end in VHF portable telephones, but a lot of amateur radio and electronics enthusiasts have used the chip for a wider variety of applications, some of which we'll talk about here. The NE602 is a strong candidate whenever you want to build a frequency converter or translator, or

even a signal-generator circuit. We can do that with oscillator circuits consisting of inductor-capacitor (L-C) variable-frequency oscillators, or piezoelectric crystals in either voltage-tuned or swept-frequency arrangements. We're going to explore some of the various configurations of circuits for the NE602 device, including the DC-power-supply connections, the RF-input configurations, the local-oscillator circuits, and the output circuits.

The NE602 version of the device operates over a temperature range of 0- to +70°C, while the related SA-602 device operates over an extended temperature range of -40- to +85°C. The most common form of the NE602, and most useful for the hobbyist and experimenter, is the NE602N, which is in an eight-pin mini-DIP package. An eight-lead surface-mount package (NE602D) is also available.

**Heart of the NE602.** Because the NE602 contains both a DBM and a local oscillator (LO), it can be used as the entire front-end of a radio receiver. Figure 2 shows a partial view of the internal circuit of the heart of the NE602: the double-balanced mixer stage. That configuration is known as a Gilbert transconductance cell. It consists of a pair of cross-coupled differential amplifiers. One feature of the design is that it offers a very good

noise figure, which is typically 5 dB at 45 MHz. The third-order intercept point is -15-dBm referenced to a matched input. Unfortunately, the dynamic range is not what it could be, so a good idea is to be sure that the input signal levels do not exceed -25 dBm ( $\approx 3.16$  mW). That signal level is similar to about 12.6 mV into a 50-ohm load, or 68 mV into the 1,500-ohm input impedance of the NE602. The NE602 is capable of providing 0.2- $\mu$ V sensitivity without the need for external RF amplification. Although the straight NE602 suffers from dynamic range problems, the improved NE602A is said to solve that problem.

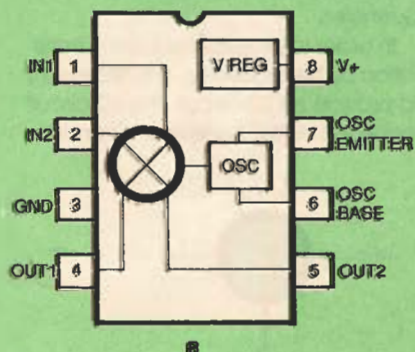
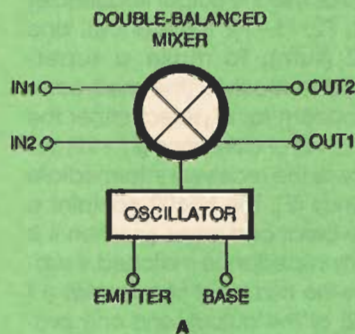

Fig. 1. The NE602 contains a double-balanced mixer and local oscillator. Here are its block diagram (A) and pinouts (B).

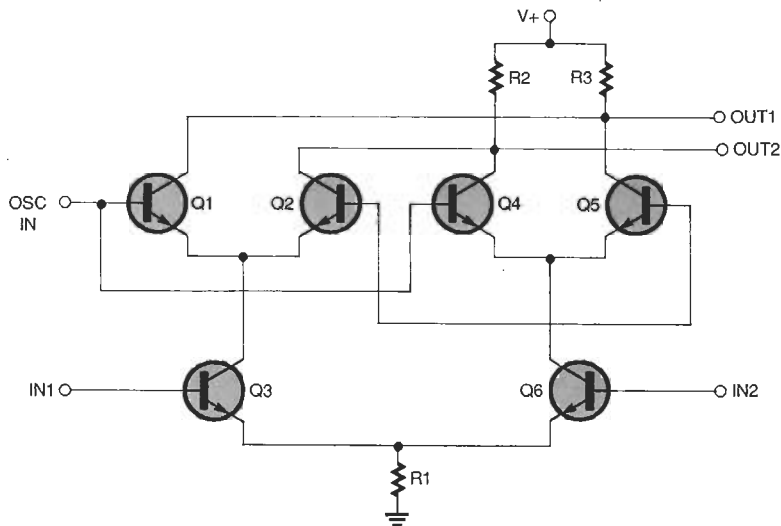

Fig. 2. The heart of the NE602: a Gilbert transconductance cell used for the double-balanced mixer.

**Frequency Translation.** The process of frequency translation or conversion is called heterodyning. When two frequencies ( $F_1$  and  $F_2$  in Fig. 3) are mixed together in a nonlinear circuit, a collection of different frequencies will appear at the output. Those frequencies are characterized as  $mF_1 + /-nF_2$ , where  $n$  and  $m$  are integers or zero (0, 1, 2, 3...). For the sake of simplicity, we normally consider only the cases where  $m$  and  $n$  are either 0 or 1, so the output frequencies are  $F_1$ ,  $F_2$ ,  $F_1 - F_2$  (difference), and  $F_1 + F_2$  (sum). To make a superheterodyne receiver (the most common modern form), select either the sum ( $F_1 + F_2$ ) or difference ( $F_1 - F_2$ ) frequency as the receiver's intermediate frequency (IF). The NE602 contains a double-balanced mixer, so when it is properly impedance matched, it suppresses the two input frequencies ( $F_1$  and  $F_2$ ) at the output, and only produces the sum and difference frequencies.

In order to provide frequency translation by heterodyning, it is necessary to provide an LO circuit. The LO circuit inside the NE602 consists of a transistor

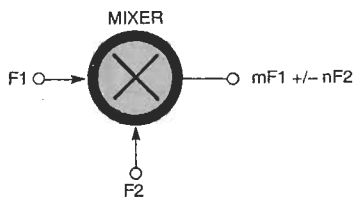

Fig. 3. In a basic mixer circuit, the sum ( $F_1 + F_2$ ) and difference ( $F_1 - F_2$ ) of two input frequencies appear at the output.

with its base and emitter elements available to the outside world. Oscillators using that circuit will operate up to 200 MHz. Any form of oscillator can be built, as long as the circuit does not need a connection to the collector of the oscillator transistor. Because of that restriction, both L-C and crystal variants of the Colpitts, Clapp, Hartley, Butler and other oscillator circuits can be built, while the Pierce and Miller circuits are not possible.

**DC Power Supply Connections.**

The power is applied to the NE602 between pins 3 (ground) and 8 ( $V_+$ ). The DC power supply voltage range is +4.5- to +8-volts DC, with a current drain ranging from 2.4 to 2.8 mA.

The DC power supply terminal (pin 8) must be decoupled with a 0.01- to 1- $\mu$ F capacitor (0.1  $\mu$ F is most common). The bypass capacitor must be mounted as close as possible to the body of the NE602, and must be capable of good performance at RF frequencies (some capacitors act like complex RLC networks at RF).

Figure 4 shows several possible DC power-supply configurations for the NE602. In Fig. 4-a, the DC power supply voltage is between +4.5 and +8-volts DC, which is the normal operating range of the device. A resistor, usually 100 to 180 ohms, is placed in series with the  $V_+$  line to the NE602. If the circuit is operated from a 9-volt DC power supply (e.g. a 9-volt DC transistor-radio battery), then the resistor should be increased to a value between 1,000 and 1,500 ohms, as in Fig. 4-b.

If the DC power supply voltage is either unstable, or at a value higher than 9-volts DC, you might want to use some form of voltage regulation. In

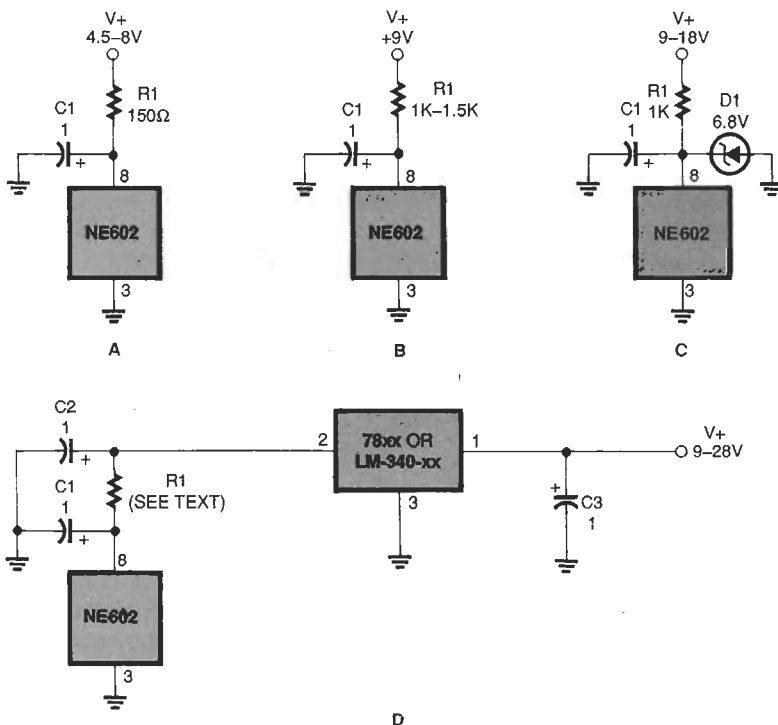

Fig. 4. There are several ways to power the NE602. A resistor should be placed in series between the power supply and the NE602 (a and b). A Zener diode (c) or a voltage regulator (d) can also be used.

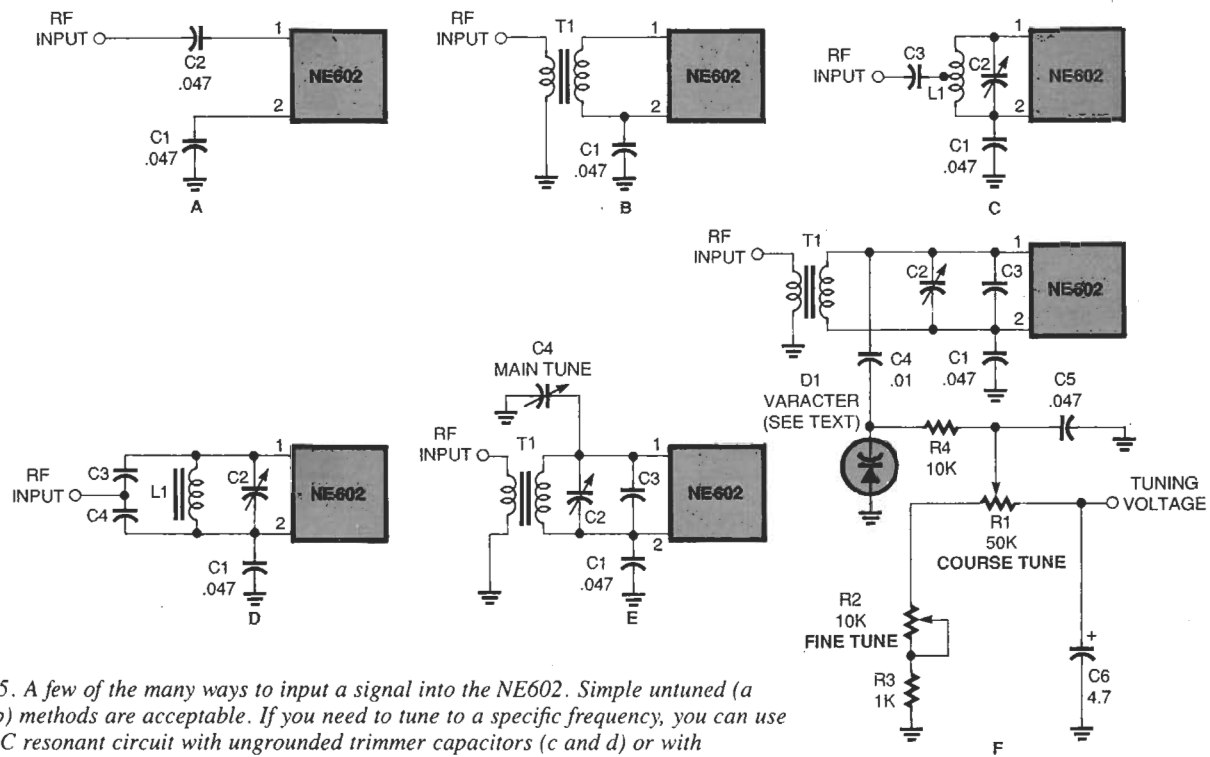

Fig. 5. A few of the many ways to input a signal into the NE602. Simple untuned (a and b) methods are acceptable. If you need to tune to a specific frequency, you can use an L-C resonant circuit with ungrounded trimmer capacitors (c and d) or with grounded variable capacitors (e). You can even use a tuning voltage in connection with a varactor (f).

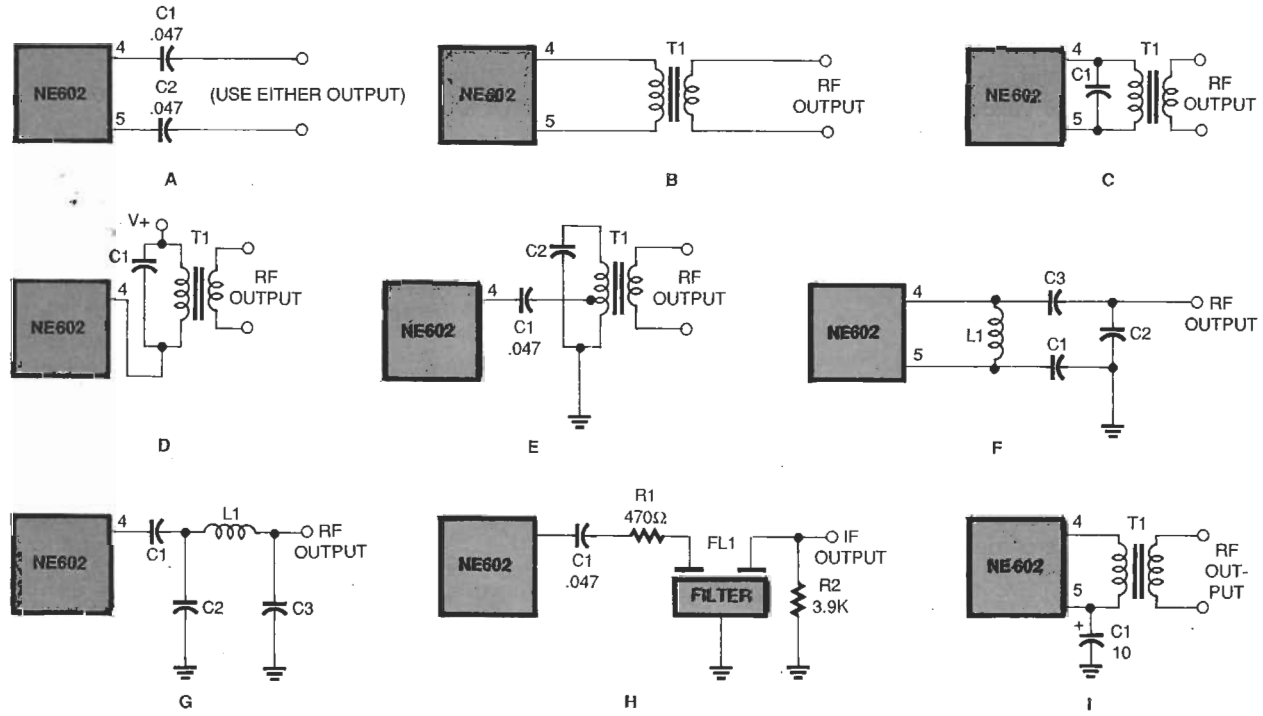

Fig. 6. The various output circuits shown here demonstrate how to either pass all the frequencies from the NE602, or allow only the sum or difference frequencies through, depending on which circuit is used.

fact, that's highly recommended. Figure 4-c shows the use of a Zener diode, rated at 6.8-volts DC, which keeps the supply voltage seen by the NE602 at that level even though the source power supply voltage might

vary from 9 to 18 volts, or so. The use of a three-terminal voltage regulator is shown in Fig. 4-d. Those devices provide a constant output voltage for a wide range of DC input voltages. A typical voltage regulator

can accept input voltages from a minimum of about 2.5-volts higher than its rated output voltage, up to a maximum of about 30 to 38 volts. Almost any positive voltage regulator can be used in the circuit of Fig. 4-d if it

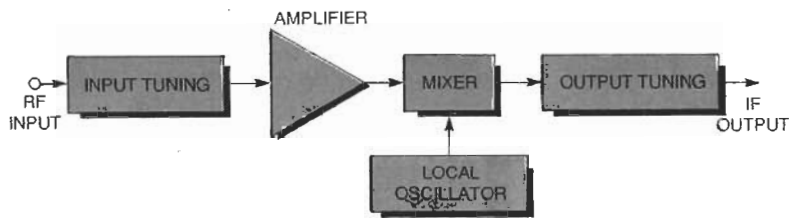

Fig. 12. If we add input and output tuning to the basic block diagram of Fig. 1-a, we can use the NE602 as a frequency translator.

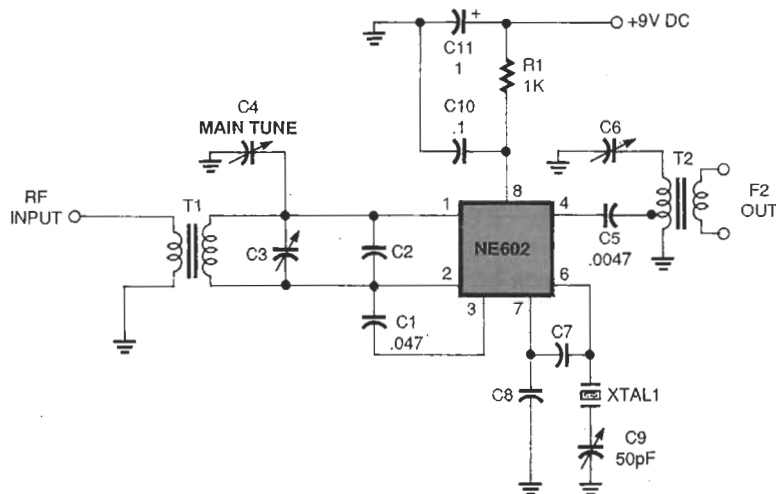

Fig. 13. This basic frequency translator/converter circuit is based on the block diagram of Fig. 12. It is useful as a demodulator in radio receivers.

and the primary of T1 as before, but the tank circuit is connected to either pin 4 or 5 and the DC-power-supply line. Another variation is shown in Fig. 6-e. There, impedance matching is provided between a higher impedance transformer primary and the output of the NE602 by using a tap on the transformer. Capacitor C1 (0.047-μF) is used to provide DC isolation between the output and the coil. That capacitor is needed because the coil is grounded. Still another variation (not shown) connects the capacitor to the top of T1, rather than a tap. That would be a grounded version of Fig. 6-d.

Still another single-ended output configuration is shown in Fig. 6-f. The inductor (L1) is connected across the balanced outputs, pins 4 and 5, but the pin 5 end is bypassed to ground through capacitor C1. The inductor is resonated by the series combination C2/C3, which also serves as a capacitor voltage divider for impedance transformation.

The output network in Fig. 6-g is an L-C low-pass filter circuit. That configuration will select the difference IF frequency (F1 - F2) if the -3-dB point of

the filter is set correctly. If you want to select the sum IF frequency (F1 + F2), then use a high-pass L-C filter. That is done by replacing C2 and C3 with inductors, and L1 with a capacitor. The values of those components can be found using the normalized method in The ARRL Radio Amateur's Handbook (any recent edition), or by using the software FilterMaker for Windows (available from the author at P.O. Box 1099, Falls Church, VA, 22041 for \$20. VA residents should add appropriate sales tax).

The network in Fig. 6-h is for use with fixed-frequency filters such as a crystal, ceramic, or mechanical types. Such filters are used to provide the IF-bandpass characteristic in receivers, and are available with characteristics from "sorta decent" for a few bucks, to real good for \$100 and up. The center frequency of the filter is set to either the sum or difference IF; and its bandwidth is set according to application (e.g. 500 Hz for CW, 2.8 kHz for SSB, or 5 to 6 kHz for AM). An output circuit for a direct-conversion receiver is shown in Fig. 6-i. A direct-conversion receiver is similar to a superheterodyne, except that the LO and RF frequencies are

very close to each other, so that the difference is the recovered audio. For example, to receive SSB, set the LO 2.8-kHz from the RF or to receive CW set it 400- to 1,000-Hz (depending on the tone you'd like to hear). To receive an AM signal, set the LO to exactly the same frequency as the RF. Transformer T1 in Fig. 6-i is an audio transformer. It can be a 1,000:1,000-ohm transformer if the next stage has a high impedance input, or it can be a 1,000:8-ohm audio-output transformer.

### NE602 Local Oscillator Circuits.

There are two general methods for controlling the frequency of the LO in any oscillator circuit: inductor-capacitor (LC) resonant tank circuits, and piezoelectric-crystal resonators. We'll talk about both methods, starting with the crystal oscillator.

Figure 7-a shows a basic Colpitts crystal oscillator. It will operate with fundamental-mode crystals on frequencies up to about 20 MHz. The feedback network consists of a capacitor voltage divider (C1/C2). The values of those capacitors are critical, and should be approximately:

$$C1 = 100 / \sqrt{F(\text{MHz})}$$

$$C2 = 1000 / F(\text{MHz})$$

The values predicted by these formulas are approximate, but work well under circumstances where external stray capacitance does not dominate the total. However, the practical truth is that capacitors come in standard values and those may not be exactly the values calculated. When the capacitor values are correct, oscillation will be consistent. If you pull the crystal out, and then reinsert it, the oscillator will restart immediately. Alternatively, if the power is turned off and then back on again, the oscillator will always restart. If the capacitor values are incorrect, then the oscillator will either fail to run at all, or will operate intermittently. Generally, an increase in the capacitances will suffice to make operation consistent.

A problem with the circuit of Fig. 7-a is that the crystal frequency is not controllable except by replacing the crystal. The actual operating frequency of any crystal depends, in part, on the circuit capacitance seen by the crystal. Most crystals are designed for load capacitances of 20 or 32 pF; but

that can be specified if crystals are being ordered directly from a manufacturer. In Fig. 7-b, a variable, or "trimmer" capacitor is placed in series with the crystal in order to set the frequency. The trimmer capacitor can be adjusted to set the oscillator to the desired frequency.

The two previous crystal oscillators operate in the fundamental mode of crystal oscillation. The resonant frequency in the fundamental mode is set by the dimensions of the slab of quartz used for the crystal; the thinner the slab, the higher the frequency. Fundamental-mode crystals work reliably up to about 20 MHz, but at higher frequencies the slabs become too thin for safe operation; at that point, the thinness of the slabs of fundamental-mode crystal causes them to fracture easily. An alternative is to use overtone-mode crystals. The overtone frequency of a crystal is not necessarily an exact harmonic of the fundamental mode, but is close to it. The overtones tend to be close to odd

integer multiples of the fundamental (3rd, 5th, 7th, etc.). Overtone crystals are marked with the appropriate overtone frequency, rather than the fundamental.

Figures 7-c and 7-d are overtone-mode crystal-oscillator circuits. The circuit in Fig. 7-c is a Butler oscillator. The overtone crystal is connected between the oscillator emitter of the NE602 (pin 7) and a capacitive voltage divider that is connected between the oscillator base (pin 6) and ground. There is also an inductor in the circuit (L1) that must resonate with C1 to the overtone frequency of crystal XTAL1. Figure 7-c can use either 3rd- or 5th-overtone crystals up to about 80 MHz. The circuit in Fig. 7-d is a third-overtone crystal oscillator that works from 25 to about 50 MHz, and is simpler than Fig. 7-c.

A pair of variable-frequency oscillator (VFO) circuits are shown in Fig. 7-e and 7-f. The circuit in Fig. 7-e is a Colpitts-oscillator version, while Fig. 7-f is a Hartley-oscillator version. In both

oscillators, the resonating element is an inductor-capacitor (LC) tuned-resonant circuit. In Fig. 7-e, however, the feedback network is a tapped-capacitor voltage divider, while in Fig. 7-f it is a tap on the resonating inductor. In both cases, a DC-blocking capacitor to pin 6 is needed in order to prevent the oscillator from being DC grounded through the resistance of the inductor.

### Voltage Tuned NE602 Oscillator Circuits.

Figure 8-a and 8-b show a pair of VFO circuits in which the capacitor element of the tuned circuit is a voltage-variable capacitance diode, or varactor (D1 in Fig. 8-a and 8-b). Those diodes exhibit a junction capacitance that varies in direct response to the reverse-bias voltage applied across the diode. Thus, the oscillating frequency of those circuits is controlled by a tuning voltage. The version shown in Fig. 8-a is a parallel-resonant Colpitts oscillator, while Fig. 8-b is a series-tuned Clapp oscillator.

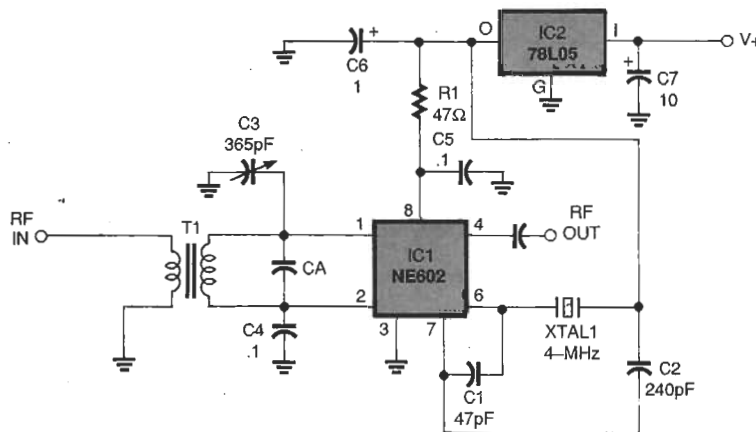

Fig. 14. Here is another simple frequency translator circuit; it does not select which frequency appears at the output.

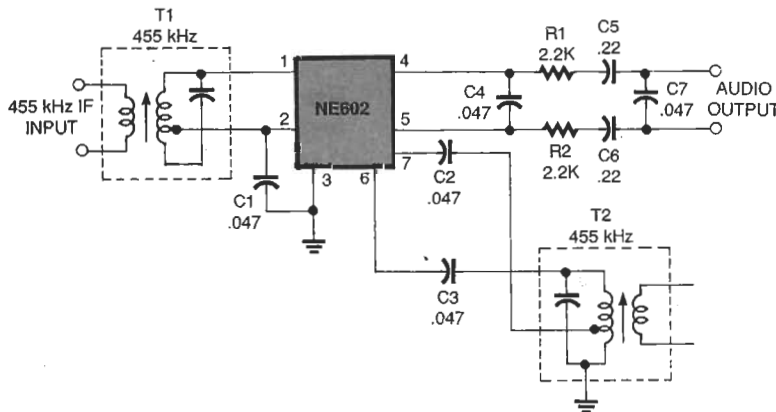

Fig. 15. After you've tuned in a particular radio frequency and demodulated it, this product-detector circuit can be used for Morse code (CW) or single-side band (SSB) reception.

### Using the NE602 as a Signal Generator.

The NE602 is normally used as a receiver front-end or as a frequency converter. It can also be used as a signal generator. Figure 9 shows the basic configuration for providing the LO signal at output pins 4 and 5; place a 10,000-ohm resistor (R1) between pin 1 and ground, while bypassing pin 2 to ground through a 0.047-µF capacitor. The output signal is taken from either pin 4 or 5 through another 0.047-µF capacitor.

The output signal of Fig. 9 will be a sine wave at the frequency of oscillation for the oscillator circuit connected to pins 6 and 7. That signal can be swept or frequency modulated by using one of the varactor LO circuits shown in Fig. 8. To sweep the frequency, make the tuning voltage a sawtooth waveform, while to frequency-modulate it, use a sine wave. If you want to amplitude-modulate the signal, then use a circuit such as Fig. 10.

The signal source is any of the NE602 oscillators (IC1 in Fig. 10), while the modulator is IC2, an MC-1350P chip. That chip is also available from the service-repair industry replacement lines as the NTE-746 or ECG-746. It is an RF-gain block with a gain-control terminal (pin 5), and that gain-control terminal can be used for the

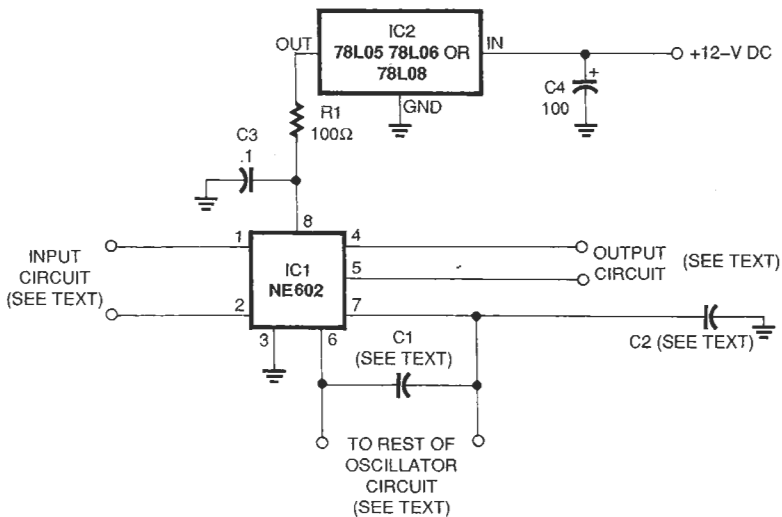

Fig. 16. There is just enough circuitry on the universal project board for NE602 to get you up and running with many different projects.

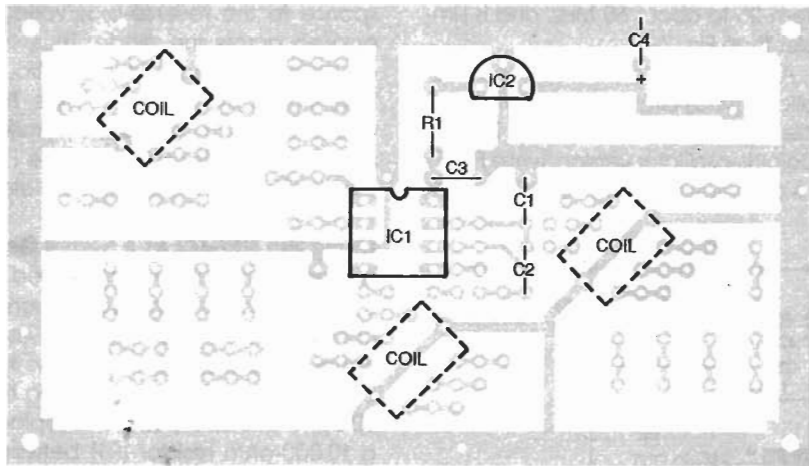
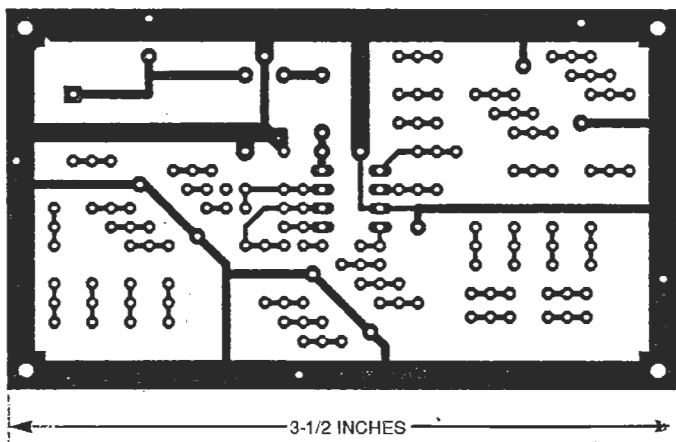

Fig. 17. Component placement on the universal project board leaves plenty of room for your own circuitry.



Here's the foil pattern for the NE602 universal project board. Many stand-alone pads are included to hold your circuitry.

amplitude-modulation function. Two signals are applied to the gain-control terminal as shown in Fig. 10; a DC level from potentiometer R4, and the

audio signal from the MODULATION LEVEL control (R5). Adjust both DC LEVEL and MODULATION LEVEL until the output signal, as viewed on an oscilloscope, looks

like Fig. 11. There should be good symmetry and no clipping of the peaks.

### Using the NE602 in Converter Projects.

The basic frequency converter was shown in block form back in Fig. 1-a; now it is time to expand upon that as shown in Fig. 12. The NE602 and its supporting circuitry might be used as the mixer and local oscillator. The amplifier is optional, and should only be used when sensitivity is poor. Poor sensitivity might be caused when insertion loss of the input tuning network is high.

The input and output tuning networks are used to segregate the signals. The input tuning selects the desired RF-input frequency ( $F_1$ ), and rejects all other frequencies. The output tuning network selects either  $F_1 - F_2$  (difference), or  $F_1 + F_2$  (sum) signals. Those filters can be L-C resonant-tank circuits, low-pass filters, high-pass filters, or band-pass filters as needed for the specific application.

Figure 13 shows a basic NE602 frequency-converter circuit. The input circuit consists of a transformer with a secondary winding resonated by C2, C3, and C4. The LO circuit is a crystal Colpitts circuit that uses a trimmer capacitor (C9) for adjusting the oscillation frequency over a small range. The output circuit is a variant of the parallel-resonant tank circuit in which the primary of the transformer (T2) is tapped to match the impedance of the NE602 output to the coil.

Another variant is shown in Fig. 14. That circuit is similar, except that the output is not tuned. The reason for that approach is that the frequency converter is used to drive the antenna input of a radio receiver, which performs the frequency selection (sum vs. difference) function.

### Using the NE602 as a Product Detector.

Figure 15 shows the circuit for a product detector based on the NE602. A product detector is a frequency converter that sets the LO frequency close enough to the RF or IF signal so a single-sideband (SSB) or CW signal is demodulated. For example, a 455-kHz IF signal from a receiver can be converted to an 800-Hz CW audio output ("beep-beep") by using an LO at 455.8 kHz or 454.2 kHz. The difference tone is found in the output.

(Continued on page 79)

---

## USING THE NE602

(Continued from page 54)

---

If the signal is an SSB signal, then the LO is set at a frequency of 2.5- to 2.8-kHz higher or lower than the IF, depending on whether you want to demodulate an upper-sideband (USB) or lower-sideband (LSB) signal.

The input signal circuit in Fig. 15 uses a 455-kHz IF transformer of the sort used for transistor radios (see Digi-Key or Mouser catalogs for suitable types). The transformer that you want to use for T1 is the type that has a resonant secondary with a tapped inductance. The LO circuit uses the same type of transformer as the input, but configured as a Hartley oscillator.

The output signal is at audio frequencies, and is filtered by an R-C network. The audio output is balanced, so it should be fed to a differential audio amplifier such as an op-amp.

### **NE602 "Universal" Project Board.**

We've included a printed circuit pattern for a "universal" project board based on the NE602. The on-board circuitry (Fig. 16) is limited to the DC power connection, which is regulated by a three-terminal IC voltage regulator. All other functions can be set by you to make any project that you want. There are a large number of multi-pad stand-alone connections for various components depending on the circuit that you want to make, as well as positions for three six-pin standard shielded coils of the sort manufactured by Toko and sold by Digi-Key. You can also use these same holes for mounting home-brew toroid inductors. Figure 17 shows the parts placement of the universal project board. The universal NE602 board can be bought from FAR Circuits, 18N640 Field Court, Dundee, IL, 60118 for \$4 plus \$1.50 shipping for every four boards ordered (*i.e.* 1 to 4 boards shipped for \$1.50). IL residents will have to add appropriate sales tax.

Now you've seen how well-behaved the NE602 is. Here is an RF chip that will function in a variety of applications from receivers, to converters, to oscillators, to signal generators. With the universal project board, the task of testing a new design based on the NE602 becomes "duck soup."  $\Omega$