

Ask The Applications Engineer—11

by James Bryant

All analog-to-digital converters (ADCs) and digital-to-analog converters (DACs) require a reference signal, usually a voltage. The digital output of the ADC represents the ratio of the input to the reference, the digital input to a DAC defines the ratio of its analog output to its reference. Some converters have their references built-in, some require an external reference, but all must have a voltage (or current) reference of some sort.

Most early applications of data converters were in “dc” measurements of slowly varying signals, where the exact timing of the measurement was unimportant. Today most data-converter applications are in *sampled data systems*, where large numbers of equally spaced analog samples must be processed and spectral information is as important as amplitude information. Here the quality of the frequency or time reference (the “sampling clock” or “reconstruction clock”) is comparable in importance to that of the voltage reference.

VOLTAGE REFERENCES

Q. *How good must a voltage reference be?*

A. It depends on the system. Where absolute measurements are required, accuracy is limited by the accuracy with which the reference value is known. In many systems, however, stability or repeatability are more important than absolute accuracy; and in some sampled-data systems the long-term accuracy of the voltage reference is scarcely important at all—but errors can be introduced by deriving reference from a noisy system supply.

Monolithic buried-Zener references (for example the AD588 and AD688) can have initial accuracy of 1 mV in 10V (0.01% or 100 ppm) and a temperature coefficient of 1.5 ppm/°C. They are accurate enough to use untrimmed in 12-bit systems (1 LSB = 244 ppm) but not in 14- or 16-bit systems. With the initial error trimmed to zero, they can be used in 14- and 16-bit systems over a limited temperature range. (1 LSB = 61 ppm, a 40°C temperature change in an AD588 or AD688).

For higher absolute accuracy, the temperature of the reference may need to be stabilized in a thermostatically controlled oven and calibrated against a standard. In many systems, while 12-bit absolute accuracy is unnecessary, 12-bit or higher resolution may be required; here, less accurate (and less costly) bandgap references may be used.

Q. *What do you mean by “buried Zener” and “bandgap”?*

A. These are the two commonest types of precision references used in integrated circuits.

The “buried” or subsurface Zener is the more stable and accurate. It consists of a diode with the correct value of reverse-breakdown voltage, formed below the surface level of the integrated-circuit chip, then covered by a protective diffusion to keep the breakdown below the surface.

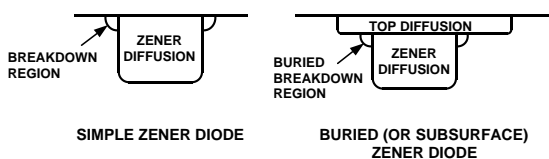

At the surface of a silicon chip there are more impurities, mechanical stresses and crystal-lattice dislocations than within the chip. Since these contribute to noise and long-term instability, the buried breakdown diode is less noisy and much more stable than surface Zeners—it is the preferred on-chip reference source for accurate IC devices.

However, its breakdown voltage is normally about 5V or more and it must draw several hundred microamperes for optimum operation, so the technique is not suitable for references which must run from low voltage and have low power consumption. For such applications, the “bandgap” reference is preferred. It develops a voltage with a positive temperature coefficient to compensate for the negative temperature coefficient of a transistor’s V_{be} , maintaining a constant “bandgap” voltage. In the circuit shown,* Q2 has 8 times the emitter area of Q1; the pair produces a current proportional to their absolute temperature (PTAT) in R1, developing a PTAT voltage in series with the V_{be} of Q1, resulting in a voltage, V_z , which does not vary with temperature and can be amplified, as shown. It is equal to the silicon bandgap voltage (extrapolated to absolute zero).

Bandgap references are somewhat less accurate and stable than the best buried-Zener references, but temperature variation of better than 3 ppm/°C may be achieved.

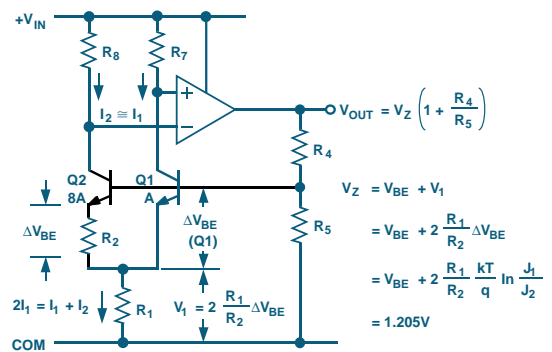

Q. *What precautions should I take when using voltage references?*

A. Remember the basics of good analog circuit design: beware of voltage drops in high impedance conductors, noise from common ground impedances, and noise from inadequately decoupled supply rails. Consider in which direction the reference current is flowing, and be careful of capacitive loads.

Q. *I know about the effects of voltage drop and noise, but do references have to supply large-enough currents for voltage drop in conductors to be significant?*

A. Generally, references are internally buffered; most will source and sink 5-10 mA. Some applications may require currents of this order or greater; an example is where the reference serves as the system reference; another is in driving the reference input of a high speed flash ADC which, has very low impedance. A current of 10 mA flowing in 100 mΩ will experience a voltage drop of 1 mV, which may be significant. The highest-performance voltage references, such as the AD588 and AD688, have Kelvin (force-sense) connections for both their output and output ground terminals. By closing a feedback

*From *Analog Dialogue* 9-1 (1975) also *The Best of Analog Dialogue*, 1967 to 1991, p. 72.

loop around the sources of error, these connections avoid the effects of voltage drops; they also correct gain and offset errors when current-buffer amplifiers are used to drive substantial loads or sink currents flowing in the wrong direction. The sense terminal should be connected to the output side of the buffer amplifier, preferably at the load.

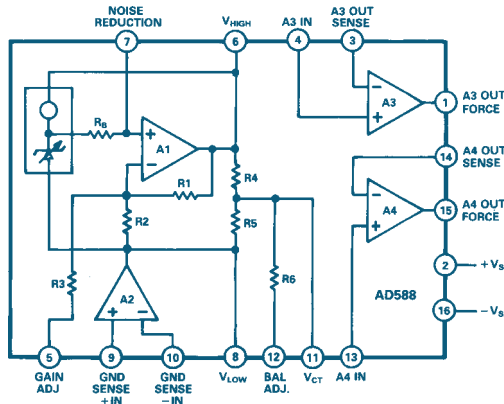

Q. What do you mean by flow in the wrong direction?”

A. Consider a +5-V reference operated from a +10-V supply. If its 5-volt output terminal is loaded by a resistor to ground, current will flow out of the terminal. If the resistor is instead connected to the +10-V supply, current will flow into the terminal. Most references will allow net current flow in either direction; but some will source current but not sink it—or will sink much less than can be sourced. Such devices, identifiable by the way their output current is specified on the data sheet, may not be used in applications where substantial net current must flow *into* the reference terminal. A common example is the use of a positive reference as a negative reference.

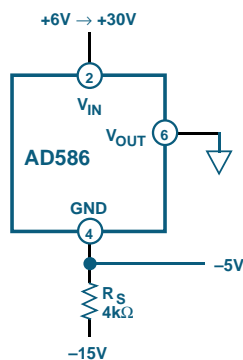

Q. Why not just buy a negative reference?

A. Because most single voltage-output references are positive references. Two-pin active references, of course, can be used for either polarity; they are used in the same way as Zener diodes (and they are usually bandgap devices).

For a three-terminal positive reference to be used as a negative reference, it must be able to sink current. Its output terminal is connected to ground and its ground terminal (which becomes the negative-reference terminal) is connected to the negative supply via a resistor (or a constant current source). The positive supply pin must generally be connected to a positive supply at least a few volts above ground. But some devices can provide negative reference in the two-terminal mode: the positive and output terminals are connected together to ground.

R_S (or a current source) must be chosen so that for all expected values of negative supply and reference load current the ground- and output-terminal currents are within ratings.

Q. What about capacitive loads?

A. Many references have output amplifiers that become unstable and may oscillate when operated with large capacitive loads; so it is inadvisable to connect high capacitance (several μF or more) to the output of a reference to reduce noise, but 1-10 nF capacitors are often recommended—and some references (e.g., AD588) have noise-reduction terminals to which capacitance can be safely connected. If force-sense terminals are available, it may be possible to tailor loop dynamics under capacitive load. Consult data sheets and manufacturers’ Application Engineers to be sure. Even if the circuit is stable, it may not be advisable to use large capacitive loads since they increase the turn-on time of the reference.

Q. Don’t references turn on as soon as power is applied?

A. By no means. In many references the current that drives the reference element (Zener or bandgap) is derived from the stabilized output. This positive feedback increases *dc* stability but leads to a stable “off” state that resists startup. On-chip circuitry to deal with this and facilitate startup is normally designed to draw minimal current, so many references come up somewhat slowly (1-10 ms is typical). Some devices are indeed specified for faster turn-on; but some are even slower.

If the designer needs reference voltage very quickly after power is applied to the circuit, the reference chosen must have a sufficiently fast turn-on specification; and noise reduction capacitance should be minimized. Reference turn-on delay may limit the opportunities for strobing the supplies of data conversion systems in order to conserve system power. The problem must still be considered even if the reference is built into the converter chip; it is also important in systems of this type to consider the power-up characteristics of the converter as well [discussed in “Ask The Applications Engineer—1,” *Analog Dialogue* 22-2 (1988), p. 29].

High-precision references may require an additional period of thermal stabilization after turn-on before the chip reaches thermal stability and thermally induced offsets arrive at their final values. Such effects will be mentioned on the data sheet and are unlikely to exceed a few seconds.

Q. Does using these high precision references instead of its internal reference make a converter more accurate?

A. Not necessarily. For example, the AD674B, a high-speed descendant of the classical AD574, has a factory-trimmed calibration error of 0.25% (± 10 LSB) max, with an internal reference guaranteed accurate to within +100 mV (1%). Since 0.25% of 10 V = 25 mV, full scale is 10.000 V + 25 mV. Suppose that an AD674B with a 1% high internal reference (10.1 V) had been factory-trimmed for 10.000 V full scale, by a 1% gain increase. If an accurate 10.00-V AD588 system reference were to be connected to the device’s reference input, full scale would become 10.100 V, at 4 times the specified max error.

Q. Please discuss the role of the clock as a system reference.

A. Oops, we’re out of space! This question introduces a topic that merits thoughtful discussion. We’ll do it in a future issue. ▶