

# PC Power Saver



Wolfgang Gscheidle (Germany)

This circuit is designed to help minimise the quiescent power consumption of PCs and notebooks, using just our old friend the 555 timer and a relay as the main components. The circuit itself dissipates around 0.5 W in operation (that is, when the connected PC is on); when switched off (with the relay not energised) the total power draw is precisely zero. A prerequisite for the circuit is a PC or notebook with a USB or PS/2 keyboard socket that is powered only when the PC is on.

The power saver can be used to switch PCs or even whole multi-way extension leads. The unit can be built into an ordinary mains adaptor (which must have an earth pin!) as the photograph of the author's prototype shows. The PC is plugged in to the socket at the output of the power saver unit, and an extra connection is made to the control input of the unit from a PS/2 (keyboard or mouse) socket or USB port. Only the 5 V supply line of the interface is used.

When button S1 on the power saver is pressed the unit turns on, and the monostable formed by the 555 timer is triggered via the network composed by R4 and C7. This drives relay RE1, whose contacts close. The connected PC is now tentatively powered up via the relay for a period determined by P1 (approximately in the range from 5 s to 10 s).

If, during this interval, the PC fails to indicate that it is alive by supplying 5 V from its USB or PS/2 connector (that is, if you do not switch it on), the monostable period will expire, the relay will drop out and any connected device will be powered down. No further current will be drawn from the supply, and, of course, it will not be possible to turn the PC on. Whenever you want to turn the PC on, you must always press the button on the power saver shortly beforehand.

If, however, 5 V is delivered by the PC to the input of optocoupler IC2 before the monostable times out (which will be the case if the PC is switched on during that period), the transistor in the optocoupler will conduct and discharge capacitor C6. The monostable will now remain triggered and the relay will remain energised until the PC is switched off and power disappears from its USB or PS/2 interface. Then, after the monostable time period expires, the relay will drop out and the power saver will disconnect itself from the

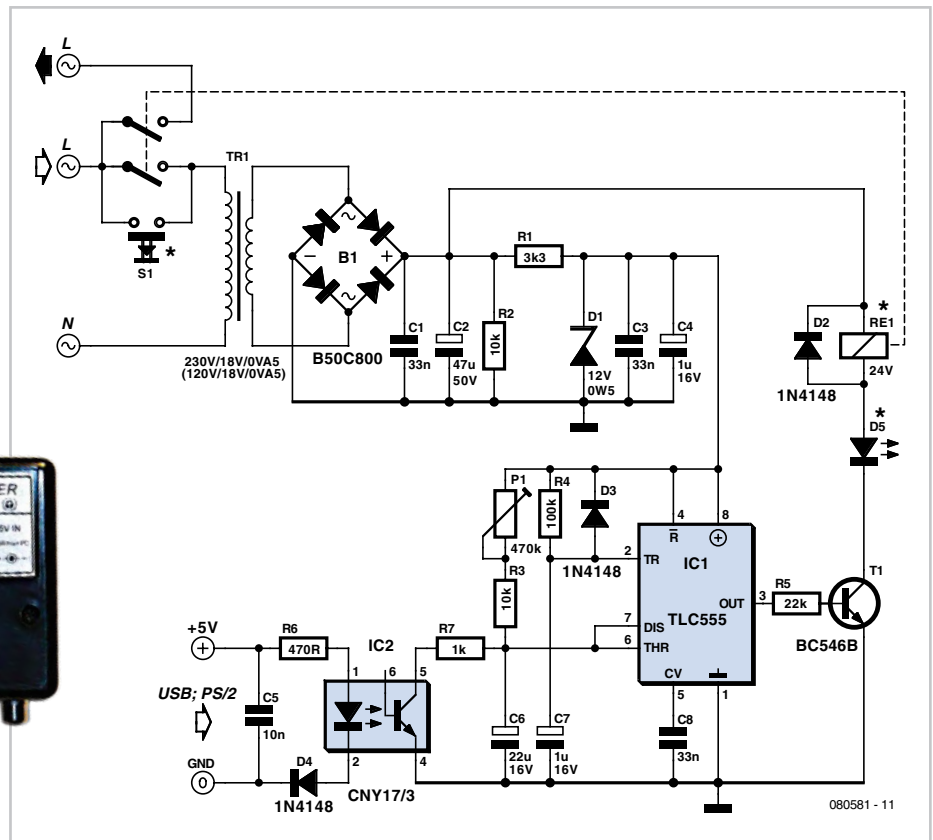

used to supply power to the device itself, and the other contact carries all the current for the connected PC or for the extension lead to which the PC and peripherals are connected.

mains. There is no need to switch anything else off: just shut down the system and the power saver will take care of the rest. It is also possible to leave the machine as it updates its software, and the power saver will do its job shortly after the machine shuts down.

Power for the unit itself is obtained using a simple supply circuit based around a miniature transformer. Alternatively, a 12 V mains adaptor can be used, as long as a relay with a 12 V coil voltage is used for RE1. In his prototype the author used a relay with a 24 V coil connected as shown directly to the positive side of reservoir capacitor C2, the 555 being powered from 12 V regulated from that supply using R1 and D1. A fixed resistor can of course be used in place of P1 if desired. If the adjustment range of P1 is not sufficient (for example if the PC powers up very slowly) the monostable period can be increased by using a larger capacitor at C6.

The relay must have at least two normally-open (or changeover) contacts rated at at least 8 A. The contact in parallel with S1 is

Pushbutton S1 **must be rated for 230 VAC (US: 120 VAC) operation**: this is no place to make economies. The coil current for the relay flows through LED D5, which must therefore be a 20 mA type. If a low-current LED is used, a 120 Ω resistor can be connected in parallel with it to carry the remaining current. The Fujitsu FTR-F1CL024R relay used in the author's prototype has a rated coil current of 16.7 mA.

Optocoupler IC2 provides isolation between the circuit and the PC, and is protected from reverse polarity connection by diode D4. The power saver should be built into an insulated enclosure and great care should be taken to ensure that there is proper isolation between components and wires carrying the mains voltage and the other parts of the circuit. In particular, the connection to the PC and associated components (R6, C5, D4 and IC2) should be carefully arranged with at least a 6 mm gap between them and any part of the circuit at mains potential.

(080581-1)