

# Easily Tuned Sine Wave Oscillators

National Semiconductor  
Linear Brief 16



One approach to generating sine waves is to filter a square wave. This leaves only the sine wave fundamental as the output. Since a square wave is easily amplitude stabilized by clipping, the sine wave output is also amplitude stabilized. A clipping oscillator eliminates the problems encountered with agc stabilized oscillators such as those using Wein bridges. Additionally, since there is no slow agc loop, the oscillator starts quickly and reaches final amplitude within a few cycles.

If a lower distortion oscillator is needed, the circuit in *Figure 2* can be used. Instead of driving the tuned circuit with a square wave, a symmetrically clipped sine wave is used. The clipped sine wave, of course, has less distortion than a square wave and yields a low distortion output when filtered. This circuit is not as tolerant of component values as the one shown in *Figure 1*. To insure oscillation, it is necessary that sufficient signal is applied to the zeners for clipping to occur. Clipping about 20% of the sine wave is usually a good value. The level of clipping must be high enough to

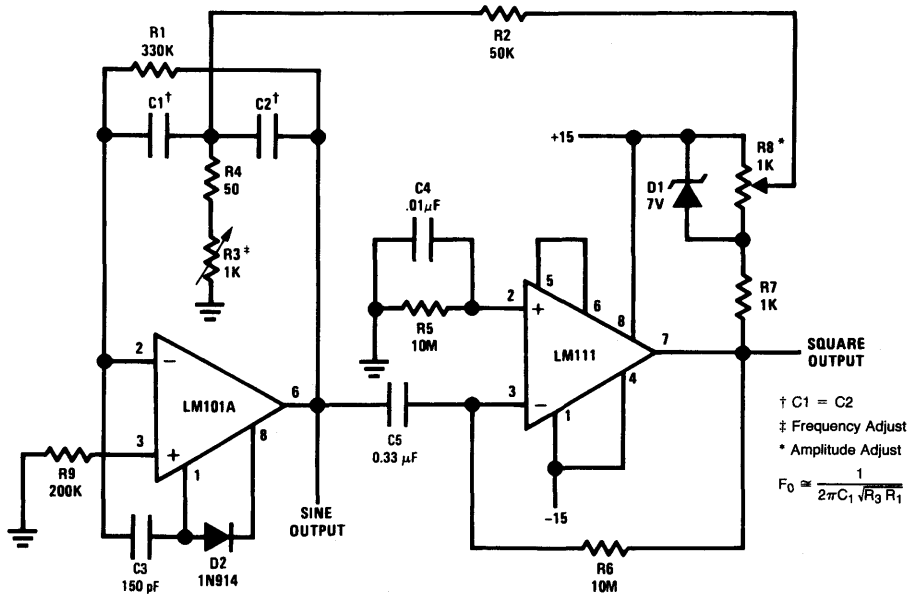

TL/H/8466-1

FIGURE 1. Easily Tuned Sine Wave Oscillator

The circuit in *Figure 1* will provide both a sine and square wave output for frequencies from below 20 Hz to above 20 kHz. The frequency of oscillation is easily tuned by varying a single resistor. This is a considerable advantage over Wein bridge circuits where two elements must be tuned simultaneously to change frequency. Also, the output amplitude is relatively stable when the frequency is changed.

An operational amplifier is used as a tuned circuit, driven by square wave from a voltage comparator. Frequency is controlled by R<sub>1</sub>, R<sub>2</sub>, C<sub>1</sub>, C<sub>2</sub>, and R<sub>3</sub>, with R<sub>3</sub> used for tuning. Tuning the filter does not affect its gain or bandwidth so the output amplitude does not change with frequency. A comparator is fed with the sine wave output to obtain a square wave. The square wave is then fed back to the input of the tuned circuit to cause oscillation. Zener diode, D<sub>1</sub>, stabilizes the amplitude of the square wave fed back to the filter input. Starting is insured by R<sub>6</sub> and C<sub>5</sub> which provide dc negative feedback around the comparator. This keeps the comparator in the active region.

insure oscillation over the entire tuning range. If the clipping is too small, it is possible for the circuit to cease oscillation due to tuning, component aging, or temperature changes. Higher clipping levels increase distortion. As with the circuit in *Figure 1*, this circuit is self-starting.

Table I shows the component values for the various frequency ranges. Distortion from the circuit in *Figure 1* ranges between 0.75% and 2% depending on the setting of R<sub>3</sub>. Although greater tuning range can be accomplished by increasing the size of R<sub>3</sub> beyond 1 kΩ, distortion becomes excessive. Decreasing R<sub>3</sub> lower than 50Ω can make the filter oscillate by itself. The circuit in *Figure 2* varies between 0.2% and 0.4% distortion for 20% clipping.

About 20 kHz is the highest usable frequency for these oscillators. At higher frequencies the tuned circuit is incapable of providing the high Q bandpass characteristic needed to filter the input into a clean sine wave. The low frequency end of oscillation is not limited except by capacitor size.

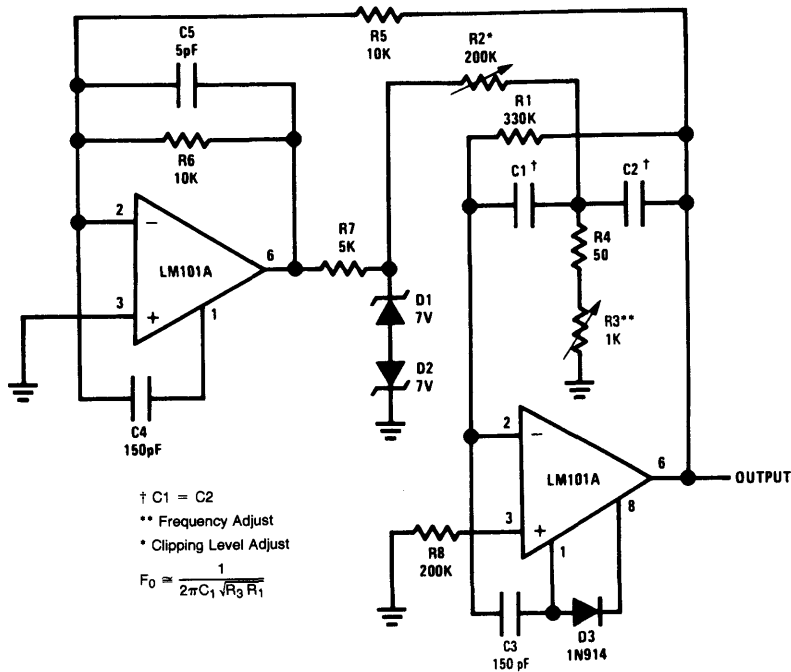

FIGURE 2. Low Distortion Sine Wave Oscillator

TL/H/8466-2

TABLE I

C <sub>1</sub> , C <sub>2</sub>	Min Frequency	Max Frequency
0.47 μF	18 Hz	80 Hz
0.1 μF	80 Hz	380 Hz
.022 μF	380 Hz	1.7 kHz
.0047 μF	1.7 kHz	8 kHz
.002 μF	4.4 kHz	20 kHz

In both oscillators, feedforward compensation<sup>3</sup> is used on the LM101A amplifiers to increase their bandwidth. Feedforward increases the bandwidth to over 10 MHz and the slew rate to better than 10 V/μs. With standard compensation the maximum output frequency would be limited to about 6 kHz.

Although these oscillators are not particularly tricky, good construction techniques are important. Since the amplifiers and the comparators are both wide band devices, proper power supply bypassing is in order. Both the positive and negative supplies should be bypassed with a 0.1 μF disc ceramic capacitor. The fast transition at the output of the comparator can be coupled to the sine wave output by stray

capacitance, causing spikes on the output. Therefore the output of the comparator with the associated circuitry should be shielded from the inputs of the op amp.

Component choice is also important. Good quality resistors and capacitors must be used to insure temperature stability. Capacitor should be mylar, polycarbonate, or polystyrene — electrolytics will not work. One percent resistors are usually adequate.

The circuits shown provide an easy method of generating a sine wave. The frequency of oscillation can be varied over greater than a 4 to 1 range by changing a single resistor. The ease of tuning as well as the elimination of critical ac loops make these oscillators well suited for high volume production since no component selection is necessary.

REFERENCES

1. N.P. Doyle, "Swift, Sure Design of Active Bandpass Filters," *EDN*, Vol. 15, No. 2, January 15, 1970.
2. R.J. Widlar, "Precision IC Comparator Runs from 5V Logic Supply," *National Semiconductor AN-41*, October, 1970.
3. Robert C. Dobkin, "Feedforward Compensation Speeds Op Amp," *National Semiconductor LB-2*, March, 1969.