

AN1040

Mounting Considerations for Power Semiconductors

Prepared by Bill Roehr
 Staff Consultant, Motorola Semiconductor Sector

TABLE OF CONTENTS

Introduction	1	Connecting and Handling Terminals	14
Mounting Surface Preparation	2	Cleaning Circuit Boards	16
Interface Decisions	3	Thermal System Evaluation	16
Insulation Considerations	4	Appendix A Thermal Resistance Concepts	17
Fastener and Hardware Characteristics	7	Appendix B Measurement of Interface	18
Fastening Techniques	8	Appendix C Sources of Accessories	19
Free Air and Socket Mounting	13	Package Index	20

INTRODUCTION

Current and power ratings of semiconductors are inseparably linked to their thermal environment. Except for lead-mounted parts used at low currents, a heat exchanger is required to prevent the junction temperature from exceeding its rated limit, thereby running the risk of a high failure rate. Furthermore, the semiconductor industry's field history indicated that the failure rate of most silicon semiconductors decreases approximately by one-half for a decrease in junction temperature from 160°C to 135°C.⁽¹⁾ Guidelines for designers of military power supplies impose a 110°C limit upon junction temperature.⁽²⁾ Proper mounting minimizes the temperature gradient between the semiconductor case and the heat exchanger.

Most early life field failures of power semiconductors can be traced to faulty mounting procedures. With metal packaged devices, faulty mounting generally causes unnecessarily high junction temperature, resulting in reduced component lifetime, although mechanical damage has occurred on occasion from improperly mounting to a warped surface. With the widespread use of various plastic-packaged semiconductors, the prospect of mechanical damage is very significant. Mechanical damage can impair the case moisture resistance or crack the semiconductor die.

(1) MIL-HANDBOOK — 2178, SECTION 2.2.
 (2) "Navy Power Supply Reliability — Design and Manufacturing Guidelines" NAVMAT P4855-1, Dec. 1982 NAVPUBFORCEN, 5801 Tabor Ave., Philadelphia, PA 19120.

Cho-Therm is a registered trademark of Chromerics, Inc.
 Grafoil is a registered trademark of Union Carbide
 Kapton is a registered trademark of E.I. DuPont
 Rubber-Duc is a trademark of AAVID Engineering
 Sil Pad is a trademark of Berquist
 Sync-Nut is a trademark of ITW Shakeproof
 Thermafil is a registered trademark and Thermafilm is a trademark of Thermalloy, Inc.
 ICePAK, Full Pak, POWERTAP and Thermopad are trademarks of Motorola, Inc.

Figure 1 shows an example of doing nearly everything wrong. A tab mount TO-220 package is shown being used as a replacement for a TO-213AA (TO-66) part which was socket mounted. To use the socket, the leads are bent — an operation which, if not properly done, can crack the package, break the internal bonding wires, or crack the die. The package is fastened with a sheet-metal screw through a 1/4" hole containing a fiber-insulating sleeve. The force used to tighten the screw tends to pull the package into the hole, possibly causing enough distortion to crack the die. In addition the contact area is small because of the area consumed by the large hole and the bowing of the package; the result is a much higher junction temperature than expected. If a rough heatsink surface and/or burrs around the hole were displayed in the illustration, most but not all poor mounting practices would be covered.

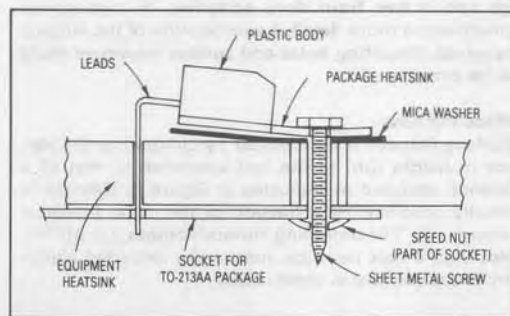

Figure 1. Extreme Case of Improperly Mounting A Semiconductor (Distortion Exaggerated)



In many situations the case of the semiconductor must be electrically isolated from its mounting surface. The isolation material is, to some extent, a thermal isolator as well, which raises junction operating temperatures. In addition, the possibility of arc-over problems is introduced if high voltages are present. Various regulating agencies also impose creepage distance specifications which further complicates design. Electrical isolation thus places additional demands upon the mounting procedure.

Proper mounting procedures usually necessitate orderly attention to the following:

1. Preparing the mounting surface
2. Applying a thermal grease (if required)
3. Installing the insulator (if electrical isolation is desired)
4. Fastening the assembly
5. Connecting the terminals to the circuit

In this note, mounting procedures are discussed in general terms for several generic classes of packages. As newer packages are developed, it is probable that they will fit into the generic classes discussed in this note. Unique requirements are given on data sheets pertaining to the particular package. The following classes are defined:

- Stud Mount
- Flange Mount
- Pressfit
- Plastic Body Mount
- Tab Mount
- Surface Mount

Appendix A contains a brief review of thermal resistance concepts. Appendix B discusses measurement difficulties with interface thermal resistance tests. Appendix C indicates the type of accessories supplied by a number of manufacturers.

MOUNTING SURFACE PREPARATION

In general, the heatsink mounting surface should have a flatness and finish comparable to that of the semiconductor package. In lower power applications, the heatsink surface is satisfactory if it appears flat against a straight edge and is free from deep scratches. In high-power applications, a more detailed examination of the surface is required. Mounting holes and surface treatment must also be considered.

Surface Flatness

Surface flatness is determined by comparing the variance in height (Δh) of the test specimen to that of a reference standard as indicated in Figure 2. Flatness is normally specified as a fraction of the Total Indicator Reading (TIR). The mounting surface flatness, i.e. $\Delta h/TIR$, if less than 4 mils per inch, normal for extruded aluminum, is satisfactory in most cases.

Surface Finish

Surface finish is the average of the deviations both above and below the mean value of surface height. For minimum interface resistance, a finish in the range of 50 to 60 microinches is satisfactory; a finer finish is costly to achieve and does not significantly lower contact resis-

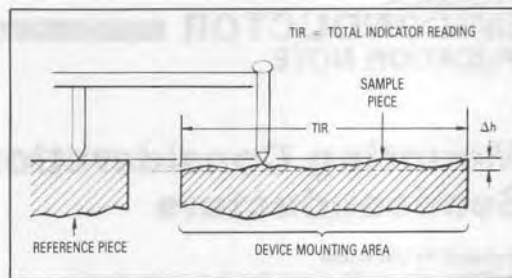

Figure 2. Surface Flatness Measurement

tance. Tests conducted by Thermalloy using a copper TO-204 (TO-3) package with a typical 32-microinch finish, showed that heatsink finishes between 16 and 64 μ -in caused less than $\pm 2.5\%$ difference in interface thermal resistance when the voids and scratches were filled with a thermal joint compound.⁽³⁾ Most commercially available cast or extruded heatsinks will require spotfacing when used in high-power applications. In general, milled or machined surfaces are satisfactory if prepared with tools in good working condition.

Mounting Holes

Mounting holes generally should only be large enough to allow clearance of the fastener. The larger thick flange type packages having mounting holes removed from the semiconductor die location, such as the TO-3, may successfully be used with larger holes to accommodate an insulating bushing, but many plastic encapsulated packages are intolerant of this condition. For these packages, a smaller screw size must be used such that the hole for the bushing does not exceed the hole in the package.

Punched mounting holes have been a source of trouble because if not properly done, the area around a punched hole is depressed in the process. This "crater" in the heatsink around the mounting hole can cause two problems. The device can be damaged by distortion of the package as the mounting pressure attempts to conform it to the shape of the heatsink indentation, or the device may only bridge the crater and leave a significant percentage of its heat-dissipating surface out of contact with the heatsink. The first effect may often be detected immediately by visual cracks in the package (if plastic), but usually an unnatural stress is imposed, which results in an early-life failure. The second effect results in hotter operation and is not manifested until much later.

Although punched holes are seldom acceptable in the relatively thick material used for extruded aluminum heatsinks, several manufacturers are capable of properly utilizing the capabilities inherent in both fine-edge blanking or sheared-through holes when applied to sheet metal as commonly used for stamped heatsinks. The holes are pierced using Class A progressive dies mounted on four-post die sets equipped with proper pressure pads and holding fixtures.

(3) Catalog #87-HS-9 (1987), page 8, Thermalloy, Inc., P.O. Box 810839, Dallas, Texas 75381-0839.

When mounting holes are drilled, a general practice with extruded aluminum, surface cleanup is important. Chamfers must be avoided because they reduce heat transfer surface and increase mounting stress. However, the edges must be broken to remove burrs which cause poor contact between device and heatsink and may puncture isolation material.

Surface Treatment

Many aluminum heatsinks are black-anodized to improve radiation ability and prevent corrosion. Anodizing results in significant electrical but negligible thermal insulation. It need only be removed from the mounting area when electrical contact is required. Heatsinks are also available which have a nickel plated copper insert under the semiconductor mounting area. No treatment of this surface is necessary.

Another treated aluminum finish is iridite, or chromate-acid dip, which offers low resistance because of its thin surface, yet has good electrical properties because it resists oxidation. It need only be cleaned of the oils and films that collect in the manufacture and storage of the sinks, a practice which should be applied to all heatsinks.

For economy, paint is sometimes used for sinks; removal of the paint where the semiconductor is attached is usually required because of paint's high thermal resistance. However, when it is necessary to insulate the semiconductor package from the heatsink, hard anodized or painted surfaces allow an easy installation for low voltage applications. Some manufacturers will provide anodized or painted surfaces meeting specific insulation voltage requirements, usually up to 400 volts.

It is also necessary that the surface be free from all foreign material, film, and oxide (freshly bared aluminum forms an oxide layer in a few seconds). Immediately prior to assembly, it is a good practice to polish the mounting area with No. 000 steel wool, followed by an acetone or alcohol rinse.

INTERFACE DECISIONS

When any significant amount of power is being dissipated, something must be done to fill the air voids between mating surfaces in the thermal path. Otherwise the interface thermal resistance will be unnecessarily high and quite dependent upon the surface finishes.

For several years, thermal joint compounds, often called grease, have been used in the interface. They have a resistivity of approximately $60^{\circ}\text{C}/\text{W}/\text{in}$ whereas air has $1200^{\circ}\text{C}/\text{W}/\text{in}$. Since surfaces are highly pock-marked with minute voids, use of a compound makes a significant reduction in the interface thermal resistance of the joint. However, the grease causes a number of problems, as discussed in the following section.

To avoid using grease, manufacturers have developed dry conductive and insulating pads to replace the more traditional materials. These pads are conformal and therefore partially fill voids when under pressure.

Thermal Compounds (Grease)

Joint compounds are a formulation of fine zinc or other conductive particles in a silicone oil or other synthetic base fluid which maintains a grease-like consistency with time and temperature. Since some of these compounds do not spread well, they should be evenly applied in a

very thin layer using a spatula or lintless brush, and wiped lightly to remove excess material. Some cyclic rotation of the package will help the compound spread evenly over the entire contact area. Some experimentation is necessary to determine the correct quantity; too little will not fill all the voids, while too much may permit some compound to remain between well mated metal surfaces where it will substantially increase the thermal resistance of the joint.

To determine the correct amount, several semiconductor samples and heatsinks should be assembled with different amounts of grease applied evenly to one side of each mating surface. When the amount is correct a very small amount of grease should appear around the perimeter of each mating surface as the assembly is slowly torqued to the recommended value. Examination of a dismantled assembly should reveal even wetting across each mating surface. In production, assemblers should be trained to slowly apply the specified torque even though an excessive amount of grease appears at the edges of mating surfaces. Insufficient torque causes a significant increase in the thermal resistance of the interface.

To prevent accumulation of airborne particulate matter, excess compound should be wiped away using a cloth moistened with acetone or alcohol. These solvents should not contact plastic-encapsulated devices, as they may enter the package and cause a leakage path or carry in substances which might attack the semiconductor chip.

The silicone oil used in most greases has been found to evaporate from hot surfaces with time and become deposited on other cooler surfaces. Consequently, manufacturers must determine whether a microscopically thin coating of silicone oil on the entire assembly will pose any problems. It may be necessary to enclose components using grease. The newer synthetic base greases show far less tendency to migrate or creep than those made with a silicone oil base. However, their currently observed working temperature range are less, they are slightly poorer on thermal conductivity and dielectric strength and their cost is higher.

Data showing the effect of compounds on several package types under different mounting conditions is shown in Table 1. The rougher the surface, the more valuable the grease becomes in lowering contact resistance; therefore, when mica insulating washers are used, use of grease is generally mandatory. The joint compound also improves the breakdown rating of the insulator.

Conductive Pads

Because of the difficulty of assembly using grease and the evaporation problem, some equipment manufacturers will not, or cannot, use grease. To minimize the need for grease, several vendors offer dry conductive pads which approximate performance obtained with grease. Data for a greased bare joint and a joint using Grafoil, a dry graphite compound, is shown in the data of Figure 3. Grafoil is claimed to be a replacement for grease when no electrical isolation is required; the data indicates it does indeed perform as well as grease. Another conductive pad available from Aavid is called KON-DUX. It is made with a unique, grain oriented, flake-like structure (patent pending). Highly compressible, it becomes

Table 1
Approximate Values for Interface Thermal Resistance Data from Measurements Performed
in Motorola Applications Engineering Laboratory

Dry interface values are subject to wide variation because of extreme dependence upon surface conditions. Unless otherwise noted the case temperature is monitored by a thermocouple located directly under the die reached through a hole in the heatsink. (See Appendix B for a discussion of Interface Thermal Resistance Measurements.)

Package Type and Data		Interface Thermal Resistance ($^{\circ}\text{C}/\text{W}$)						
JEDEC Outlines	Description	Test Torque In-Lb	Metal-to-Metal		With Insulator			See Note
			Dry	Lubed	Dry	Lubed	Type	
DO-203AA, TO-210AA TO-208AB	10-32 Stud 7/16" Hex	15	0.3	0.2	1.6	0.8	3 mil Mica	
DO-203AB, TO-210AC TO-208	1/4-28 Stud 11/16" Hex	25	0.2	0.1	0.8	0.6	5 mil Mica	
DO-208AA	Pressfit, 1/2"	—	0.15	0.1	—	—	—	
TO-204AA (TO-3)	Diamond Flange	6	0.5	0.1	1.3	0.36	3 mil Mica	1
TO-213AA (TO-66)	Diamond Flange	6	1.5	0.5	2.3	0.9	2 mil Mica	
TO-126	Thermopad 1/4" x 3/8"	6	2.0	1.3	4.3	3.3	2 mil Mica	
TO-220AB	Thermowatt	8	1.2	1.0	3.4	1.6	2 mil Mica	1, 2

NOTES: 1. See Figures 3 and 4 for additional data on TO-3 and TO-220 packages.
 2. Screw not insulated. See Figure 12.

formed to the surface roughness of both the heatsink and semiconductor. Manufacturer's data shows it to provide an interface thermal resistance better than a metal interface with filled silicone grease. Similar dry conductive pads are available from other manufacturers. They are a fairly recent development; long term problems, if they exist, have not yet become evident.

INSULATION CONSIDERATIONS

Since most power semiconductors use vertical device construction it is common to manufacture power semiconductors with the output electrode (anode, collector or drain) electrically common to the case; the problem of isolating this terminal from ground is a common one. For lowest overall thermal resistance, which is quite important when high power must be dissipated, it is best to isolate the entire heatsink/semiconductor structure from ground, rather than to use an insulator between the semiconductor and the heatsink. Heatsink isolation is not always possible, however, because of EMI requirements, safety reasons, instances where a chassis serves as a heatsink or where a heatsink is common to several non-isolated packages. In these situations insulators are used to isolate the individual components from the heatsink. Newer packages, such as the Motorola Full Pak and EMS modules, contain the electrical isolation material within, thereby saving the equipment manufacturer the burden of addressing the isolation problem.

Insulator Thermal Resistance

When an insulator is used, thermal grease is of greater importance than with a metal-to-metal contact, because two interfaces exist instead of one and some materials,

such as mica, have a hard, markedly uneven surface. With many isolation materials reduction of interface thermal resistance of between 2 to 1 and 3 to 1 are typical when grease is used.

Data obtained by Thermalloy, showing interface resistance for different insulators and torques applied to TO-204 (TO-3) and TO-220 packages, are shown in Figure 3, for bare and greased surfaces. Similar materials to those shown are available from several manufacturers. It is obvious that with some arrangements, the interface thermal resistance exceeds that of the semiconductor (junction to case).

Referring to Figure 3, one may conclude that when high power is handled, beryllium oxide is unquestionably the best. However, it is an expensive choice. (It should not be cut or abraded, as the dust is highly toxic.) Thermafilm is a filled polyimide material which is used for isolation (variation of Kapton). It is a popular material for low power applications because of its low cost ability to withstand high temperatures, and ease of handling in contrast to mica which chips and flakes easily.

A number of other insulating materials are also shown. They cover a wide range of insulation resistance, thermal resistance and ease of handling. Mica has been widely used in the past because it offers high breakdown voltage and fairly low thermal resistance at a low cost but it certainly should be used with grease.

Silicone rubber insulators have gained favor because they are somewhat conformal under pressure. Their ability to fill in most of the metal voids at the interface reduces the need for thermal grease. When first introduced, they suffered from cut-through after a few years in service. The ones presently available have solved this problem by having imbedded pads of Kapton or fiberglass. By

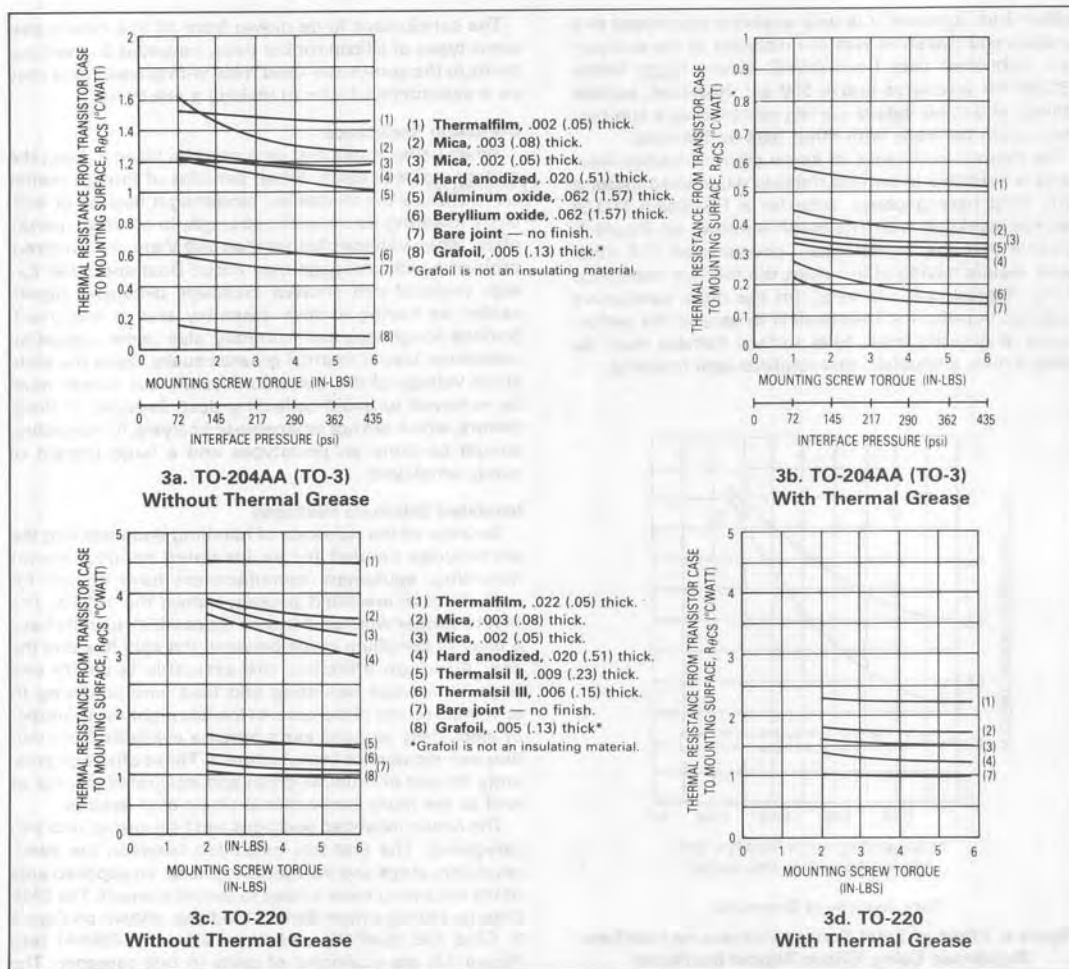

Figure 3. Interface Thermal Resistance for TO-204, TO-3 and TO-220 Packages using Different Insulating Materials as a Function of Mounting Screw Torque (Data Courtesy Thermalloy)

comparing Figures 3c and 3d, it can be noted that Thermasil, a filled silicone rubber, without grease, has about the same interface thermal resistance as greased mica for the TO-220 package.

A number of manufacturers offer silicone rubber insulators. Table 2 shows measured performance of a number of these insulators under carefully controlled, nearly identical conditions. The interface thermal resistance extremes are over 2:1 for the various materials. It is also clear that some of the insulators are much more tolerant than others of out-of-flat surfaces. Since the tests were performed, newer products have been introduced. The Bergquist K-10 pad, for example, is described as having about 2/3 the interface resistance of the Sil Pad 1000 which would place its performance close to the Chomerics 1671 pad. AAVID also offers an isolated pad called

Table 2. Thermal Resistance of Silicone Rubber Pads

Manufacturer	Product	$R_{\theta CS}$ @ 3 Mils*	$R_{\theta CS}$ @ 7.5 Mils*
Wakefield	Delta Pad 173-7	.790	1.175
Bergquist	Sil Pad K-4	.752	1.470
Stockwell Rubber	1867	.742	1.015
Bergquist	Sil Pad 400-9	.735	1.205
Thermalloy	Thermalsil II	.680	1.045
Shin-Etsu	TC-30AG	.664	1.260
Bergquist	Sil Pad 400-7	.633	1.060
Chomerics	1674	.592	1.190
Wakefield	Delta Pad 174-9	.574	.755
Bergquist	Sil Pad 1000	.529	.935
Ablestik	Thermal Wafers	.500	.990
Thermalloy	Thermalsil III	.440	1.035
Chomerics	1671	.367	.655

*Test Fixture Deviation from flat from Thermalloy EIR86-1010.

Rubber-Duc, however it is only available vulcanized to a heatsink and therefore was not included in the comparison. Published data from AAVID shows $R_{\theta CS}$ below 0.3°C/W for pressures above 500 psi. However, surface flatness and other details are not specified so a comparison cannot be made with other data in this note.

The thermal resistance of some silicone rubber insulators is sensitive to surface flatness when used under a fairly rigid base package. Data for a TO-204AA (TO-3) package insulated with Thermasil is shown on Figure 4. Observe that the "worst case" encountered (7.5 mils) yields results having about twice the thermal resistance of the "typical case" (3 mils), for the more conductive insulator. In order for Thermasil III to exceed the performance of greased mica, total surface flatness must be under 2 mils, a situation that requires spot finishing.

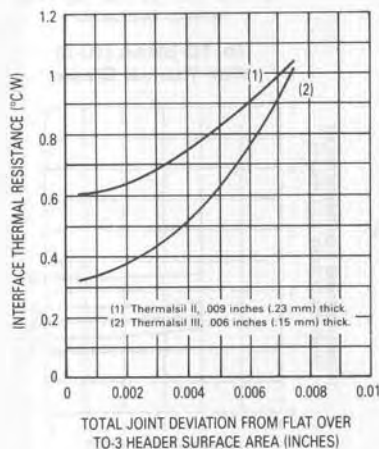

Data courtesy of Thermalloy

Figure 4. Effect of Total Surface Flatness on Interface Resistance Using Silicon Rubber Insulators

Silicon rubber insulators have a number of unusual characteristics. Besides being affected by surface flatness and initial contact pressure, time is a factor. For example, in a study of the Cho-Therm 1688 pad thermal interface impedance dropped from 0.90°C/W to 0.70°C/W at the end of 1000 hours. Most of the change occurred during the first 200 hours where $R_{\theta CS}$ measured 0.74°C/W . The torque on the conventional mounting hardware had decreased to 3 in-lb from an initial 6 in-lb. With non-conformal materials, a reduction in torque would have increased the interface thermal resistance.

Because of the difficulties in controlling all variables affecting tests of interface thermal resistance, data from different manufacturers is not in good agreement. Table 3 shows data obtained from two sources. The relative performance is the same, except for mica which varies widely in thickness. Appendix B discusses the variables which need to be controlled. At the time of this writing ASTM Committee D9 is developing a standard for interface measurements.

The conclusions to be drawn from all this data is that some types of silicon rubber pads, mounted dry, will out perform the commonly used mica with grease. Cost may be a determining factor in making a selection.

Insulation Resistance

When using insulators, care must be taken to keep the mating surfaces clean. Small particles of foreign matter can puncture the insulation, rendering it useless or seriously lowering its dielectric strength. In addition, particularly when voltages higher than 300 V are encountered, problems with creepage may occur. Dust and other foreign material can shorten creepage distances significantly; so having a clean assembly area is important. Surface roughness and humidity also lower insulation resistance. Use of thermal grease usually raises the withstand voltage of the insulation system but excess must be removed to avoid collecting dust. Because of these factors, which are not amenable to analysis, hi-pot testing should be done on prototypes and a large margin of safety employed.

Insulated Electrode Packages

Because of the nuisance of handling and installing the accessories needed for an insulated semiconductor mounting, equipment manufacturers have longed for cost-effective insulated packages since the 1950's. The first to appear were stud mount types which usually have a layer of beryllium oxide between the stud hex and the can. Although effective, the assembly is costly and requires manual mounting and lead wire soldering to terminals on top of the case. In the late eighties, a number of electrically isolated parts became available from various semiconductor manufacturers. These offerings presently consist of multiple chips and integrated circuits as well as the more conventional single chip devices.

The newer insulated packages can be grouped into two categories. The first has insulation between the semiconductor chips and the mounting base; an exposed area of the mounting base is used to secure the part. The EMS (Energy Management Series) Modules, shown on Figure 8, Case 806 (ICePAK) and Case 388A (TO-258AA) (see Figure 11) are examples of parts in this category. The second category contains parts which have a plastic over-mold covering the metal mounting base. The Full Pak,

Table 3. Performance of Silicon Rubber Insulators Tested per MIL-I-49456

Material	Measured Thermal Resistance ($^{\circ}\text{C/W}$)	
	Thermalloy Data(1)	Berquist Data(2)
Bare Joint, greased	0.033	0.008
BeO, greased	0.082	—
Cho-Therm, 1617	0.233	—
Q Pad (non-insulated)	—	0.009
Sil-Pad, K-10	0.263	0.200
Thermasil III	0.267	—
Mica, greased	0.329	0.400
Sil-Pad 1000	0.400	0.300
Cho-therm 1674	0.433	—
Thermasil II	0.500	—
Sil-Pad 400	0.533	0.440
Sil-Pad K-4	0.583	0.440

(1) From Thermalloy EIR 87-1030

(2) From Berquist Data Sheet

Case 221C, illustrated in Figure 13, is an example of parts in the second category.

Parts in the first category — those with an exposed metal flange or tab — are mounted the same as their non-insulated counterparts. However, as with any mounting system where pressure is bearing on plastic, the over-molded type should be used with a conical compression washer, described later in this note.

FASTENER AND HARDWARE CHARACTERISTICS

Characteristics of fasteners, associated hardware, and the tools to secure them determine their suitability for use in mounting the various packages. Since many problems have arisen because of improper choices, the basic characteristics of several types of hardware are discussed next.

Compression Hardware

Normal split ring lock washers are not the best choice for mounting power semiconductors. A typical #6 washer flattens at about 50 pounds, whereas 150 to 300 pounds is needed for good heat transfer at the interface. A very useful piece of hardware is the conical, sometimes called a Belleville washer, compression washer. As shown in Figure 5, it has the ability to maintain a fairly constant pressure over a wide range of its physical deflection — generally 20% to 80%. When installing, the assembler applies torque until the washer depresses to half its original height. (Tests should be run prior to setting up the assembly line to determine the proper torque for the fastener used to achieve 50% deflection.) The washer will absorb any cyclic expansion of the package, insulating washer or other materials caused by temperature changes. Conical washers are the key to successful mounting of devices requiring strict control of the mounting force or when plastic hardware is used in the mounting scheme. They are used with the large face contacting the packages. A new variation of the conical washer includes it as part of a nut assembly. Called a Sync Nut, the patented device can be soldered to a PC board and the semiconductor mounted with a 6-32 machine screw.⁽⁴⁾

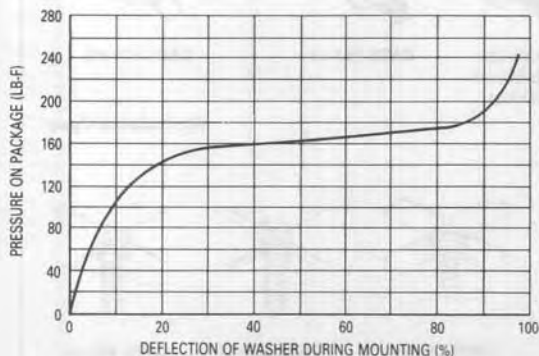

Figure 5. Characteristics of the Conical Compression Washers Designed for Use with Plastic Body Mounted Semiconductors

(4) ITW Shakeproof, St. Charles Road, Elgin, IL 60120.

Clips

Fast assembly is accomplished with clips. When only a few watts are being dissipated, the small board-mounted or free-standing heat dissipators with an integral clip, offered by several manufacturers, result in a low cost assembly. When higher power is being handled, a separate clip may be used with larger heatsinks. In order to provide proper pressure, the clip must be specially designed for a particular heatsink thickness and semiconductor package.

Clips are especially popular with plastic packages such as the TO-220 and TO-126. In addition to fast assembly, the clip provides lower interface thermal resistance than other assembly methods when it is designed for proper pressure to bear on the top of the plastic over the die. The TO-220 package usually is lifted up under the die location when mounted with a single fastener through the hole in the tab because of the high pressure at one end.

Machine Screws

Machine screws, conical washers, and nuts (or sync-nuts) can form a trouble-free fastener system for all types of packages which have mounting holes. However, proper torque is necessary. Torque ratings apply when dry; therefore, care must be exercised when using thermal grease to prevent it from getting on the threads as inconsistent torque readings result. Machine screw heads should not directly contact the surface of plastic packages types as the screw heads are not sufficiently flat to provide properly distributed force. Without a washer, cracking of the plastic case may occur.

Self-Tapping Screws

Under carefully controlled conditions, sheet-metal screws are acceptable. However, during the tapping process with a standard screw, a volcano-like protrusion will develop in the metal being threaded; an unacceptable surface that could increase the thermal resistance may result. When standard sheet metal screws are used, they must be used in a clearance hole to engage a speed-nut. If a self tapping process is desired, the screw type must be used which roll-forms machine screw threads.

Rivets

Rivets are not a recommended fastener for any of the plastic packages. When a rugged metal flange-mount package or EMS module is being mounted directly to a heatsink, rivets can be used provided press-riveting is used. Crimping force must be applied slowly and evenly. Pop-riveting should never be used because the high crimping force could cause deformation of most semiconductor packages. Aluminum rivets are much preferred over steel because less pressure is required to set the rivet and thermal conductivity is improved.

The hollow rivet, or eyelet, is preferred over solid rivets. An adjustable, regulated pressure press is used such that a gradually increasing pressure is used to pan the eyelet. Use of sharp blows could damage the semiconductor die.

Solder

Until the advent of the surface mount assembly technique, solder was not considered a suitable fastener for power semiconductors. However, user demand has led to the development of new packages for this application. Acceptable soldering methods include conventional belt-

furnace, irons, vapor-phase reflow, and infrared reflow. It is important that the semiconductor temperature not exceed the specified maximum (usually 260°C) or the die bond to the case could be damaged. A degraded die bond has excessive thermal resistance which often leads to a failure under power cycling.

Adhesives

Adhesives are available which have coefficients of expansion compatible with copper and aluminum.⁽⁵⁾ Highly conductive types are available; a 10 mil layer has approximately 0.3°C/W interface thermal resistance. Different types are offered: high strength types for non-field-serviceable systems or low strength types for field-serviceable systems. Adhesive bonding is attractive when case mounted parts are used in wave soldering assembly because thermal greases are not compatible with the conformal coatings used and the greases foul the solder process.

Plastic Hardware

Most plastic materials will flow, but differ widely in this characteristic. When plastic materials form parts of the fastening system, compression washers are highly valuable to assure that the assembly will not loosen with time and temperature cycling. As previously discussed, loss of contact pressure will increase interface thermal resistance.

FASTENING TECHNIQUES

Each of the various classes of packages in use requires different fastening techniques. Details pertaining to each type are discussed in following sections. Some general considerations follow.

To prevent galvanic action from occurring when devices are used on aluminum heatsinks in a corrosive atmosphere, many devices are nickel- or gold-plated. Consequently, precautions must be taken not to mar the finish.

Another factor to be considered is that when a copper based part is rigidly mounted to an aluminum heatsink, a bimetallic system results which will bend with temperature changes. Not only is the thermal coefficient of expansion different for copper and aluminum, but the temperature gradient through each metal also causes each component to bend. If bending is excessive and the package is mounted by two or more screws the semiconductor chip could be damaged. Bending can be minimized by:

1. Mounting the component parallel to the heatsink fins to provide increased stiffness.
2. Allowing the heatsink holes to be a bit oversized so that some slip between surfaces can occur as temperature changes.
3. Using a highly conductive thermal grease or mounting pad between the heatsink and semiconductor to minimize the temperature gradient and allow for movement.

Stud Mount

Parts which fall into the stud-mount classification are shown in Figure 6. Mounting errors with non-insulated stud-mounted parts are generally confined to application

(5) Robert Batson, Elliot Fraunglass and James P. Moran, "Heat Dissipation Through Thermalloy Conductive Adhesives," EMTAS '83. Conference, February 1-3, Phoenix, AZ; Society of Manufacturing Engineers, One SME Drive, P.O. Box 930, Dearborn, MI 48128.

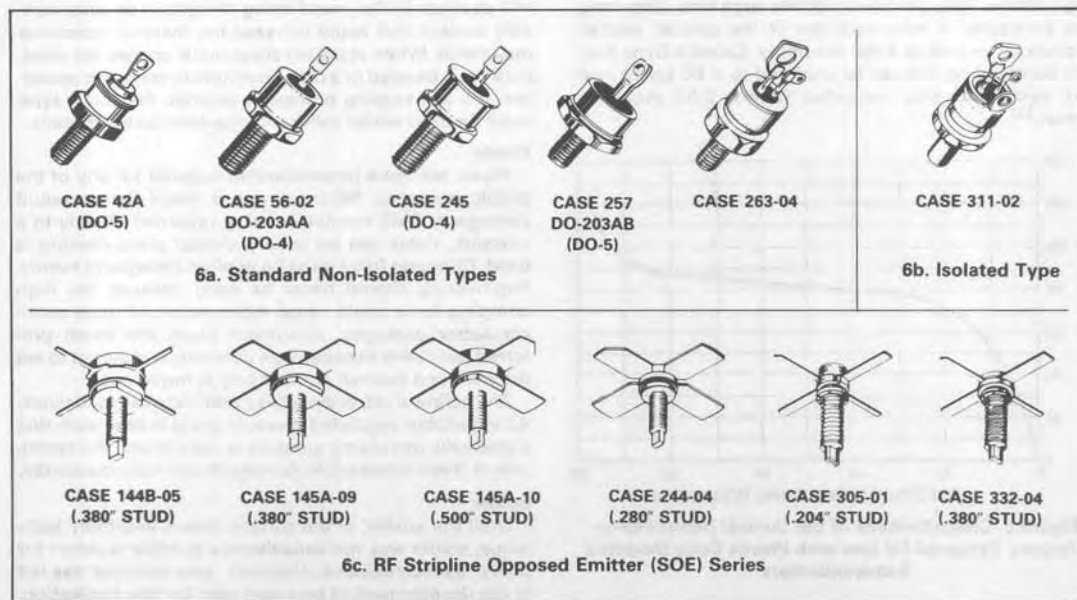

Figure 6. A Variety of Stud-Mount Parts

of excessive torque or tapping the stud into a threaded heatsink hole. Both these practices may cause a warpage of the hex base which may crack the semiconductor die. The only recommended fastening method is to use a nut and washer; the details are shown in Figure 7.

Insulated electrode packages on a stud mount base require less hardware. They are mounted the same as their non-insulated counterparts, but care must be exercised to avoid applying a shear or tension stress to the insulation layer, usually a beryllium oxide (BeO) ceramic. This requirement dictates that the leads must be attached to the circuit with flexible wire. In addition, the stud hex should be used to hold the part while the nut is torqued.

R.F. transistors in the stud-mount stripline opposed emitter (SOE) package impose some additional constraints because of the unique construction of the package. Special techniques to make connections to the stripline leads and to mount the part so no tension or shear forces are applied to any ceramic — metal interface are discussed in the section entitled "Connecting and Handling Terminals."

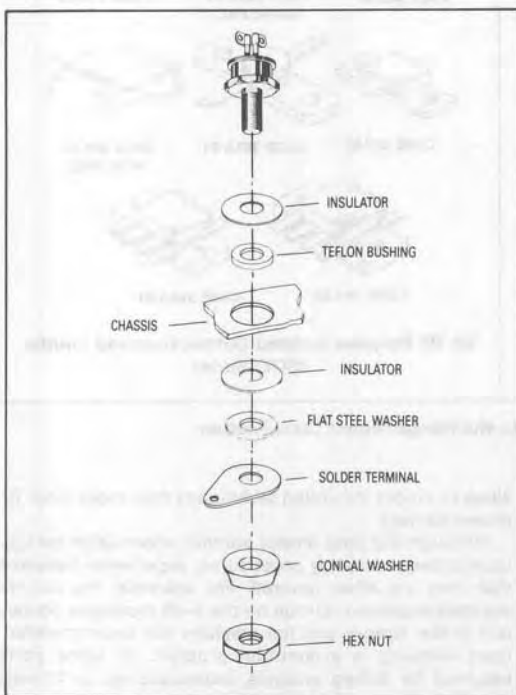

Figure 7. Isolating Hardware Used for a Non-Isolated Stud-Mount Package

Press Fit

For most applications, the press-fit case should be mounted according to the instructions shown in Figure 8. A special fixture meeting the necessary requirements must be used.

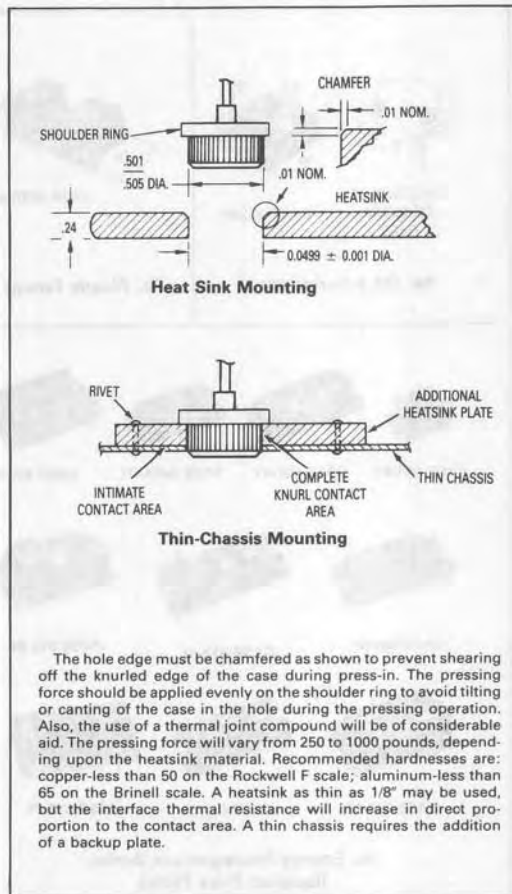

Figure 8. Press-Fit Package

The hole edge must be chamfered as shown to prevent shearing off the knurled edge of the case during press-in. The pressing force should be applied evenly on the shoulder ring to avoid tilting or canting of the case in the hole during the pressing operation. Also, the use of a thermal joint compound will be of considerable aid. The pressing force will vary from 250 to 1000 pounds, depending upon the heatsink material. Recommended hardnesses are: copper—less than 50 on the Rockwell F scale; aluminum—less than 65 on the Brinell scale. A heatsink as thin as 1/8" may be used, but the interface thermal resistance will increase in direct proportion to the contact area. A thin chassis requires the addition of a backup plate.

Flange Mount

A large variety of parts fit into the flange mount category as shown in Figure 9. Few known mounting difficulties exist with the smaller flange mount packages, such as the TO-204 (TO-3). The rugged base and distance between die and mounting holes combine to make it extremely difficult to cause any warpage unless mounted on a surface which is badly bowed or unless one side is tightened excessively before the other screw is started. It is therefore good practice to alternate tightening of the screws so that pressure is evenly applied. After the screws are finger-tight the hardware should be torqued to its final specification in at least two sequential steps. A typical mounting installation for a popular flange type part is shown in Figure 10. Machine screws (preferred) self-tapping screws, eyelets, or rivets may be used to secure the package using guidelines in the previous section. "Fastener and Hardware Characteristics."

The copper flange of the Energy Management Series (EMS) Modules is very thick. Consequently, the parts are rugged and indestructible for all practical purposes. No

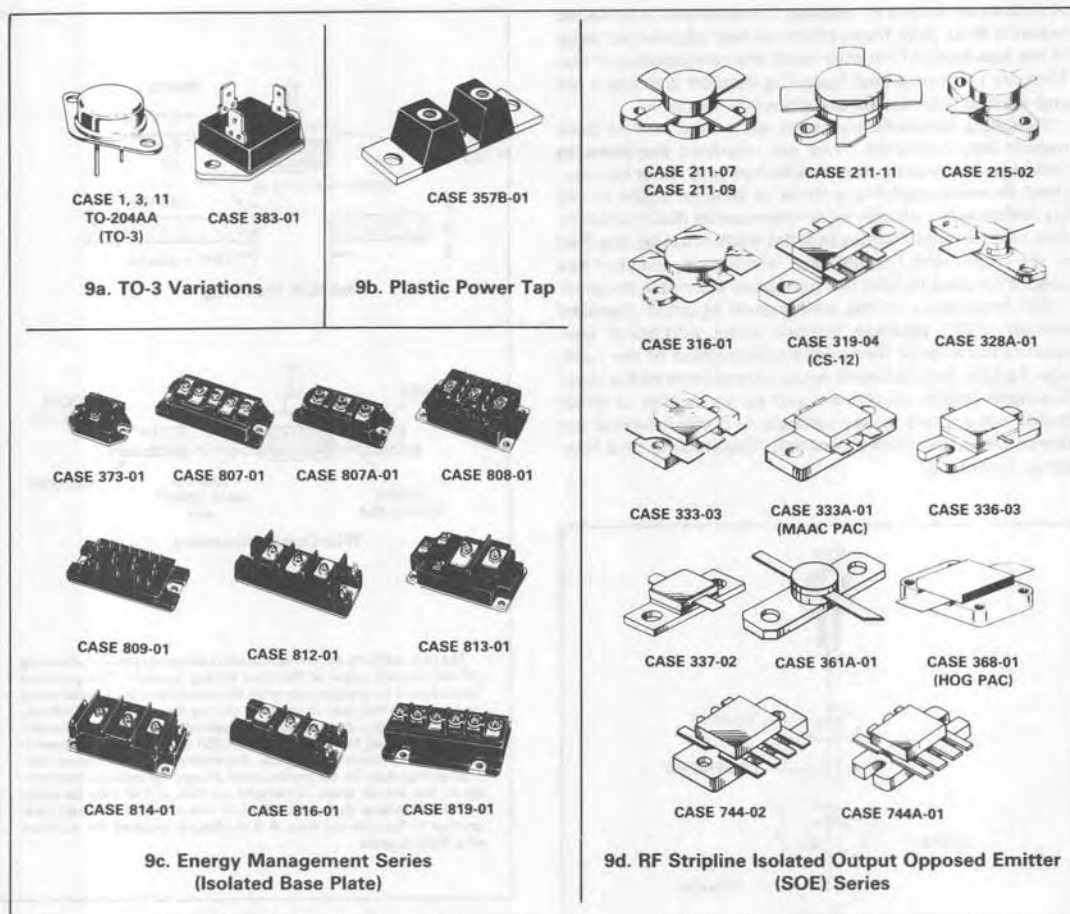

Figure 9. A Large Array of Parts Fit into the Flange-Mount Classification

special precautions are necessary when fastening these parts to a heatsink.

Some packages specify a tightening procedure. For example, with the Power Tap package, Figure 9b, final torque should be applied first to the center position.

The RF power modules (MHW series) are more sensitive to the flatness of the heatsink than other packages because a ceramic (BeO) substrate is attached to a relatively thin, fairly long, flange. The maximum allowable flange bending to avoid mechanical damage has been determined and presented in detail in EB107 "Mounting Considerations for Motorola RF Power Modules." Many of the parts can handle a combined heatsink and flange deviation from flat of 7 to 8 mils which is commonly available. Others must be held to 1.5 mils, which requires that the heatsink have nearly perfect flatness.

Specific mounting recommendations are critical to RF devices in isolated packages because of the internal ceramic substrate. The large area Case 368-1 (HOG PAC) will be used to illustrate problem areas. It is more sen-

sitive to proper mounting techniques than most other RF power devices.

Although the data sheets contain information on recommended mounting procedures, experience indicates that they are often ignored. For example, the recommended maximum torque on the 4-40 mounting screws is 5 in./lbs. Spring and flat washers are recommended. Over torquing is a common problem. In some parts returned for failure analysis, indentions up to 10 mils deep in the mounting screw areas have been observed.

Calculations indicate that the length of the flange increases in excess of two mils with a temperature change of 75°C. In such cases, if the mounting screw torque is excessive, the flange is prevented from expanding in length, instead it bends upwards in the mid-section, cracking the BeO and the die. A similar result can also occur during the initial mounting of the device if an excessive amount of thermal compound is applied. With sufficient torque, the thermal compound will squeeze out of the mounting hole areas, but will remain under the center

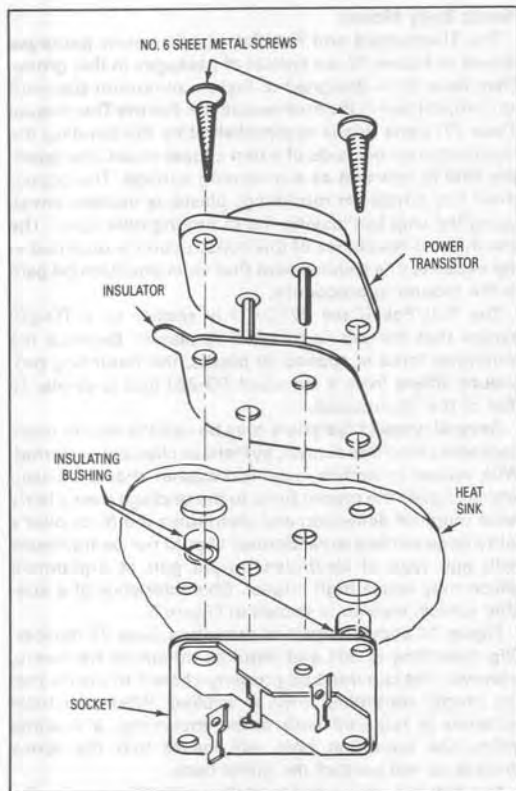

Figure 10. Hardware Used for a TO-204AA (TO-3) Flange Mount Part

of the flange, deforming it. Deformations of 2-3 mils have been measured between the center and the ends under such conditions (enough to crack internal ceramic).

Another problem arises because the thickness of the flange changes with temperature. For the 75°C temperature excursion mentioned, the increased amount is around 0.25 mils which results in further tightening of the mounting screws, thus increasing the effective torque from the initial value. With a decrease in temperature, the opposite effect occurs. Therefore thermal cycling not only causes risk of structural damage but often causes the assembly to loosen which raises the interface resistance. Use of compression hardware can eliminate this problem.

Tab Mount

The tab mount class is composed of a wide array of packages as illustrated in Figure 11. Mounting considerations for all varieties are similar to that for the popular TO-220 package, whose suggested mounting arrangements and hardware are shown in Figure 12. The rectangular washer shown in Figure 12a is used to minimize distortion of the mounting flange; excessive distortion could cause damage to the semiconductor chip. Use of

the washer is only important when the size of the mounting hole exceeds 0.140 inch (6-32 clearance). Larger holes are needed to accommodate the lower insulating bushing when the screw is electrically connected to the case; however, the holes should not be larger than necessary to provide hardware clearance and should never exceed a diameter of 0.250 inch. Flange distortion is also possible if excessive torque is used during mounting. A maximum torque of 8 inch-pounds is suggested when using a 6-32 screw.

Care should be exercised to assure that the tool used to drive the mounting screw never comes in contact with the plastic body during the driving operation. Such contact can result in damage to the plastic body and internal device connections. To minimize this problem, Motorola TO-220 packages have a chamfer on one end. TO-220 packages of other manufacturers may need a spacer or combination spacer and isolation bushing to raise the screw head above the top surface of the plastic.

The popular TO-220 Package and others of similar construction lift off the mounting surface as pressure is applied to one end. (See Appendix B, Figure B1.) To counter this tendency, at least one hardware manufacturer offers a hard plastic cantilever beam which applies more even pressure on the tab.⁽⁶⁾ In addition, it separates

(6) Catalog, Edition 18, Richco Plastic Company, 5825 N. Tripp Ave., Chicago, IL 60546.

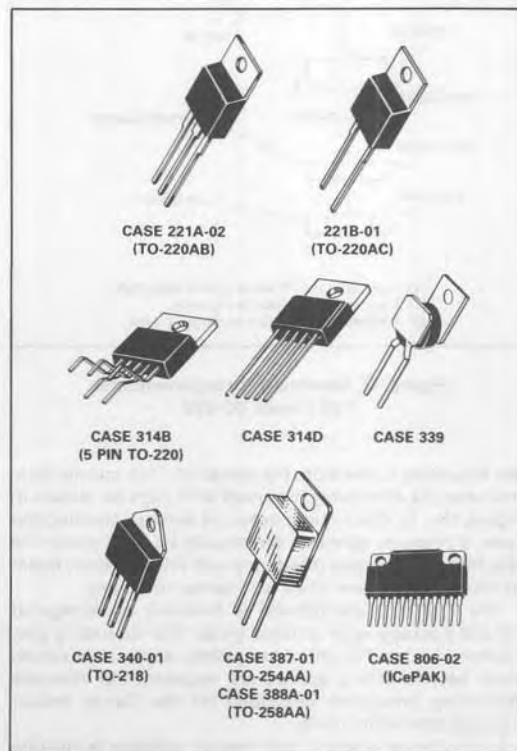

Figure 11. Several Types of Tab-Mount Parts

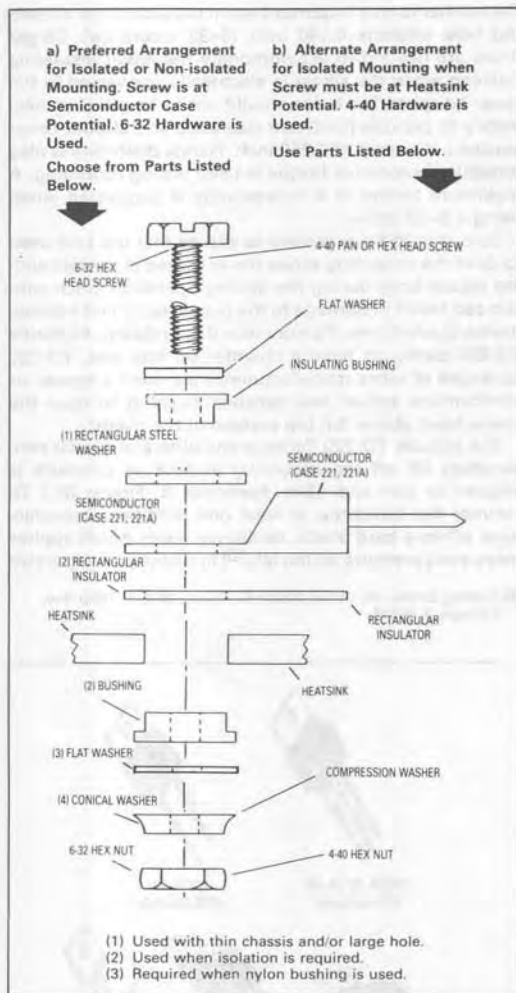

Figure 12. Mounting Arrangements for Tab Mount TO-220

the mounting screw from the metal tab. Tab mount parts may also be effectively mounted with clips as shown in Figure 15c. To obtain high pressure without cracking the case, a pressure spreader bar should be used under the clip. Interface thermal resistance with the cantilever beam or clips can be lower than with screw mounting.

The ICePAK (Case 806-02) is basically an elongated TO-220 package with isolated chips. The mounting precautions for the TO-220 consequently apply. In addition, since two mounting screws are required, the alternate tightening procedure described for the flange mount package should be used.

In situations where a tab mount package is making direct contact with the heatsink, an eyelet may be used, provided sharp blows or impact shock is avoided.

Plastic Body Mount

The Thermopad and Full Pak plastic power packages shown in Figure 13 are typical of packages in this group. They have been designed to feature minimum size with no compromise in thermal resistance. For the Thermopad (Case 77) parts this is accomplished by die-bonding the silicon chip on one side of a thin copper sheet; the opposite side is exposed as a mounting surface. The copper sheet has a hole for mounting; plastic is molded enveloping the chip but leaving the mounting hole open. The low thermal resistance of this construction is obtained at the expense of a requirement that strict attention be paid to the mounting procedure.

The Full Pak (Case 221C-01) is similar to a TO-220 except that the tab is encased in plastic. Because the mounting force is applied to plastic, the mounting procedure differs from a standard TO-220 and is similar to that of the Thermopad.

Several types of fasteners may be used to secure these packages; machine screws, eyelets, or clips are preferred. With screws or eyelets, a conical washer should be used which applies the proper force to the package over a fairly wide range of deflection and distributes the force over a fairly large surface area. Screws should not be tightened with any type of air-driven torque gun or equipment which may cause high impact. Characteristics of a suitable conical washer is shown in Figure 5.

Figure 14 shows details of mounting Case 77 devices. Clip mounting is fast and requires minimum hardware, however, the clip must be properly chosen to insure that the proper mounting force is applied. When electrical isolation is required with screw mounting, a bushing inside the mounting hole will insure that the screw threads do not contact the metal base.

The Full Pak, (Case 221C, 221D and 340B) permits the mounting procedure to be greatly simplified over that of a standard TO-220. As shown in Figure 15c, one properly chosen clip, inserted into two slotted holes in the heat-sink, is all the hardware needed. Even though clip pressure is much lower than obtained with a screw, the thermal resistance is about the same for either method. This occurs because the clip bears directly on top of the die and holds the package flat while the screw causes the package to lift up somewhat under the die. (See Figure B1 of Appendix B.) The interface should consist of a layer of thermal grease or a highly conductive thermal pad. Of course, screw mounting shown in Figure 15b may also be used but a conical compression washer should be included. Both methods afford a major reduction in hardware as compared to the conventional mounting method with a TO-220 package which is shown in Figure 15a.



Figure 13. Plastic Body-Mount Packages

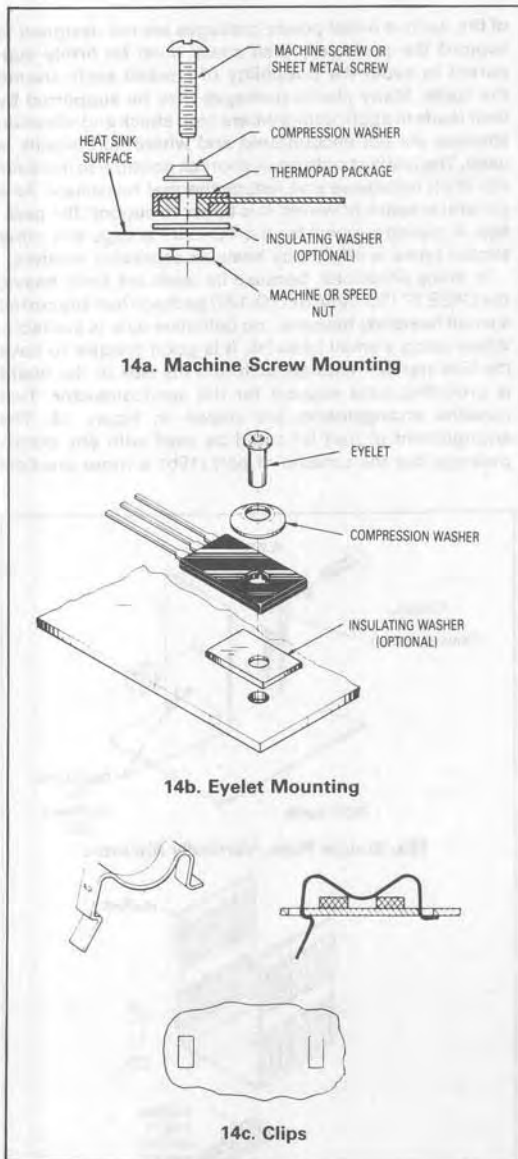

Figure 14. Recommended Mounting Arrangements for TO-225AA (TO-126) Thermopad Packages

Surface Mount

Although many of the tab mount parts have been surface mounted, special small footprint packages for mounting power semiconductors using surface mount assembly techniques have been developed. The DPAK, shown in Figure 16, for example, will accommodate a die up to 112 mils x 112 mils, and has a typical thermal resistance around 2°C/W junction to case. The thermal resistance

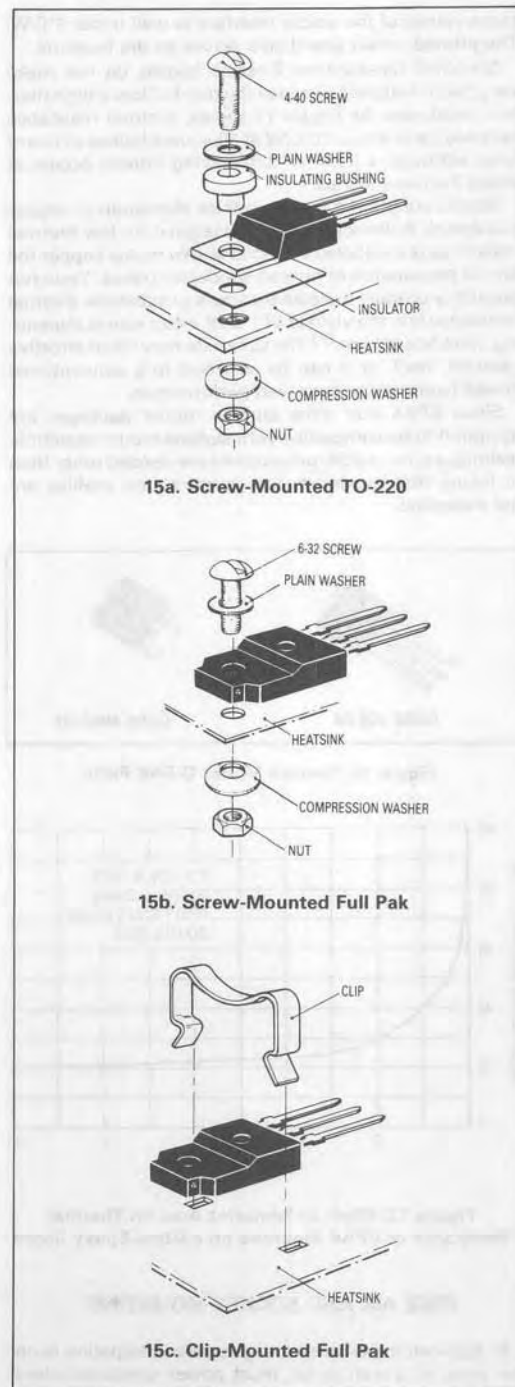

Figure 15. Mounting Arrangements for the Full Pak as Compared to a Conventional TO-220

tance values of the solder interface is well under 1°C/W. The printed circuit board also serves as the heatsink.

Standard Glass-Epoxy 2-ounce boards do not make very good heatsinks because the thin foil has a high thermal resistance. As Figure 17 shows, thermal resistance asymptotes to about 20°C/W at 10 square inches of board area, although a point of diminishing returns occurs at about 3 square inches.

Boards are offered that have thick aluminum or copper substrates. A dielectric coating designed for low thermal resistance is overlaid with one or two ounce copper foil for the preparation of printed conductor traces. Tests run on such a product indicate that case to substrate thermal resistance is in the vicinity of 1°C/W, exact values depending upon board type.⁽⁷⁾ The substrate may be an effective heatsink itself, or it can be attached to a conventional finned heatsink for improved performance.

Since DPAK and other surface mount packages are designed to be compatible with surface mount assembly techniques, no special precautions are needed other than to insure that maximum temperature/time profiles are not exceeded.



Figure 16. Surface Mount D-PAK Parts

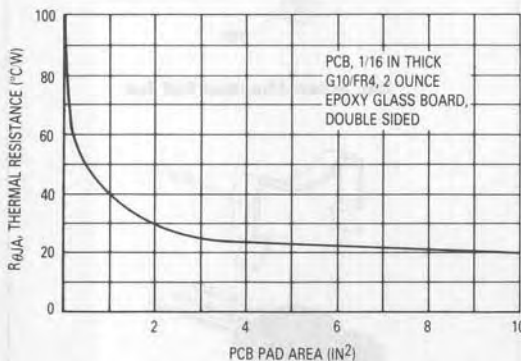

Figure 17. Effect of Footprint Area on Thermal Resistance of DPAK Mounted on a Glass-Epoxy Board

FREE AIR AND SOCKET MOUNTING

In applications where average power dissipation is on the order of a watt or so, most power semiconductors may be mounted with little or no heatsinking. The leads

(7) Herb Fick, "Thermal Management of Surface Mount Power Devices," Powerconversion and Intelligent Motion, August 1987.

of the various metal power packages are not designed to support the packages; their cases must be firmly supported to avoid the possibility of cracked seals around the leads. Many plastic packages may be supported by their leads in applications where high shock and vibration stresses are not encountered and where no heatsink is used. The leads should be as short as possible to increase vibration resistance and reduce thermal resistance. As a general practice however, it is better to support the package. A plastic support for the TO-220 Package and other similar types is offered by heatsink accessory vendors.

In many situations, because its leads are fairly heavy, the CASE 77 (TO-225AA) (TO-127) package has supported a small heatsink; however, no definitive data is available. When using a small heatsink, it is good practice to have the sink rigidly mounted such that the sink or the board is providing total support for the semiconductor. Two possible arrangements are shown in Figure 18. The arrangement of part (a) could be used with any plastic package, but the scheme of part (18b) is more practical

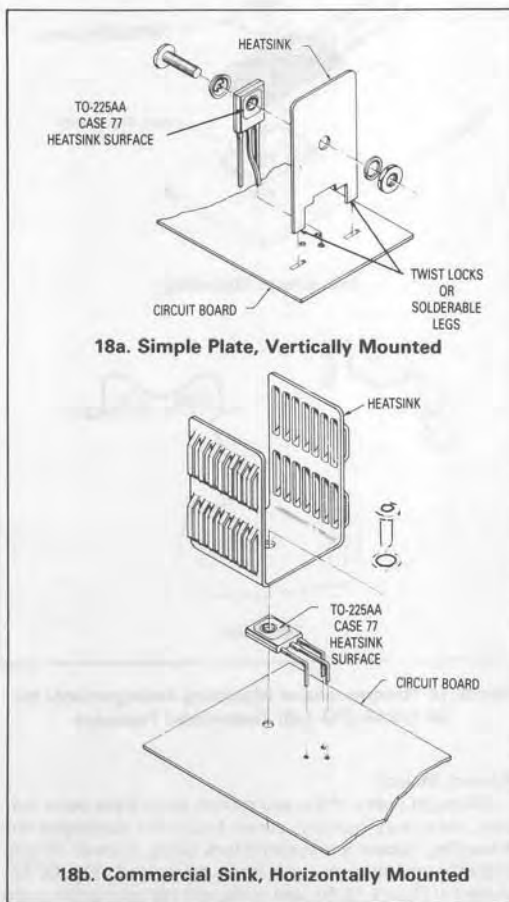

Figure 18. Methods of Using Small Heatsinks With Plastic Semiconductor Packages

with Case 77 Thermopad devices. With the other package types, mounting the transistor on top of the heatsink is more practical.

In certain situations, in particular where semiconductor testing is required or prototypes are being developed, sockets are desirable. Manufacturers have provided sockets for many of the packages available from Motorola. The user is urged to consult manufacturers' catalogs for specific details. Sockets with Kelvin connections are necessary to obtain accurate voltage readings across semiconductor terminals.

CONNECTING AND HANDLING TERMINALS

Pins, leads, and tabs must be handled and connected properly to avoid undue mechanical stress which could cause semiconductor failure. Change in mechanical dimensions as a result of thermal cycling over operating temperature extremes must be considered. Standard metal, plastic, and RF stripline packages each have some special considerations.

Metal Packages

The pins and lugs of metal packaged devices using glass to metal seals are not designed to handle any significant bending or stress. If abused, the seals could crack. Wires may be attached using sockets, crimp connectors or solder, provided the data sheet ratings are observed. When wires are attached directly to the pins, flexible or braided leads are recommended in order to provide strain relief.

EMS Modules

The screw terminals of the EMS modules look deceptively rugged. Since the flange base is mounted to a rigid heatsink, the connection to the terminals must allow some flexibility. A rigid buss bar should not be bolted to terminals. Lugs with braid are preferred.

Plastic Packages

The leads of the plastic packages are somewhat flexible and can be reshaped although this is not a recommended procedure. In many cases, a heatsink can be chosen which makes lead-bending unnecessary. Numerous lead-and-tab-forming options are available from Motorola on large quantity orders. Preformed leads remove the users risk of device damage caused by bending.

If, however, lead-bending is done by the user, several basic considerations should be observed. When bending the lead, support must be placed between the point of bending and the package. For forming small quantities of units, a pair of pliers may be used to clamp the leads at the case, while bending with the fingers or another pair of pliers. For production quantities, a suitable fixture should be made.

The following rules should be observed to avoid damage to the package.

1. A lead bend radius greater than 1/16 inch is advisable for TO-225AA (CASE 77) and 1/32 inch for TO-220.
2. No twisting of leads should be done at the case.
3. No axial motion of the lead should be allowed with respect to the case.

The leads of plastic packages are not designed to withstand excessive axial pull. Force in this direction greater than 4 pounds may result in permanent damage to the device. If the mounting arrangement imposes axial stress on the leads, a condition which may be caused by thermal cycling, some method of strain relief should be devised. When wires are used for connections, care should be

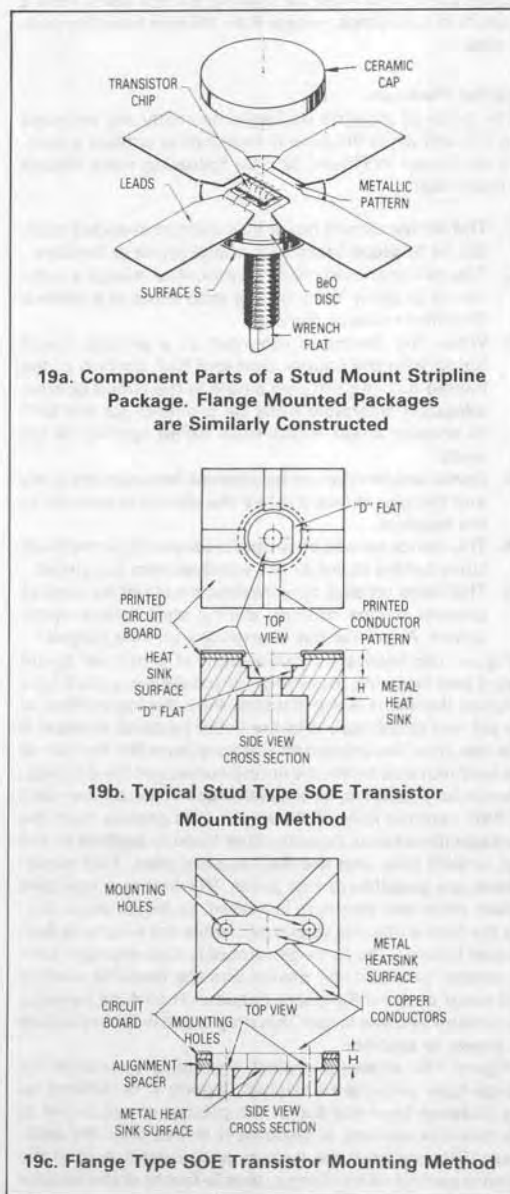

Figure 19. Mounting Details for SOE Transistors

exercised to assure that movement of the wire does not cause movement of the lead at the lead-to-plastic junctions. Highly flexible or braided wires are good for providing strain relief.

Wire-wrapping of the leads is permissible, provided that the lead is restrained between the plastic case and the point of the wrapping. The leads may be soldered; the maximum soldering temperature, however, must not exceed 260°C and must be applied for not more than 5 seconds at a distance greater than 1/8 inch from the plastic case.

Stripline Packages

The leads of stripline packages normally are soldered into a board while the case is recessed to contact a heatsink as shown in Figure 19. The following rules should be observed:

1. The device should never be mounted in such a manner as to place ceramic-to-metal joints in tension.
2. The device should never be mounted in such a manner as to apply force on the strip leads in a vertical direction towards the cap.
3. When the device is mounted in a printed circuit board with the copper stud and BeO portion of the header passing through a hole in the circuit boards, adequate clearance must be provided for the BeO to prevent shear forces from being applied to the leads.
4. Some clearance must be allowed between the leads and the circuit board when the device is secured to the heatsink.
5. The device should be properly secured into the heatsinks before its leads are attached into the circuit.
6. The leads on stud type devices must not be used to prevent device rotation during stud torque application. A wrench flat is provided for this purpose.

Figure 19b shows a cross-section of a printed circuit board and heatsink assembly for mounting a stud type stripline device. H is the distance from the top surface of the printed circuit board to the D-flat heatsink surface. If H is less than the minimum distance from the bottom of the lead material to the mounting surface of the package, there is no possibility of tensile forces in the copper stud — BeO ceramic joint. If, however, H is greater than the package dimension, considerable force is applied to the cap to BeO joint and the BeO to stud joint. Two occurrences are possible at this point. The first is a cap joint failure when the structure is heated, as might occur during the lead-soldering operation; while the second is BeO to stud failure if the force generated is high enough. Lack of contact between the device and the heatsink surface will occur as the differences between H and the package dimension become larger, this may result in device failure as power is applied.

Figure 19c shows a typical mounting technique for flange-type stripline transistors. Again, H is defined as the distance from the top of the printed circuit board to the heatsink surface. If distance H is less than the minimum distance from the bottom of transistor lead to the bottom surface of the flange, tensile forces at the various joints in the package are avoided. However, if distance H exceeds the package dimension, problems similar to those discussed for the stud type devices can occur.

CLEANING CIRCUIT BOARDS

It is important that any solvents or cleaning chemicals used in the process of degreasing or flux removal do not affect the reliability of the devices. Alcohol and unchlorinated Freon solvents are generally satisfactory for use with plastic devices, since they do not damage the package. Hydrocarbons such as gasoline and chlorinated Freon may cause the encapsulant to swell, possibly damaging the transistor die.

When using an ultrasonic cleaner for cleaning circuit boards, care should be taken with regard to ultrasonic energy and time of application. This is particularly true if any packages are free-standing without support.

THERMAL SYSTEM EVALUATION

Assuming that a suitable method of mounting the semiconductor without incurring damage has been achieved, it is important to ascertain whether the junction temperature is within bounds.

In applications where the power dissipated in the semiconductor consists of pulses at a low duty cycle, the instantaneous or peak junction temperature, not average temperature, may be the limiting condition. In this case, use must be made of transient thermal resistance data. For a full explanation of its use, see Motorola Application Note, AN569.

Other applications, notably RF power amplifiers or switches driving highly reactive loads, may create severe current crowding conditions which render the traditional concepts of thermal resistance or transient thermal impedance invalid. In this case, transistor safe operating area, thyristor di/dt limits, or equivalent ratings as applicable, must be observed.

Fortunately, in many applications, a calculation of the average junction temperature is sufficient. It is based on the concept of thermal resistance between the junction and a temperature reference point on the case. (See Appendix A.) A fine wire thermocouple should be used, such as #36 AWG, to determine case temperature. Average operating junction temperature can be computed from the following equation:

$$T_J = T_C + R_{\theta JC} \times P_D$$

where T_J = junction temperature (°C)

T_C = case temperature (°C)

$R_{\theta JC}$ = thermal resistance junction-to-case as specified on the data sheet (°C/W)

P_D = power dissipated in the device (W)

The difficulty in applying the equation often lies in determining the power dissipation. Two commonly used empirical methods are graphical integration and substitution.

Graphical Integration

Graphical integration may be performed by taking oscilloscope pictures of a complete cycle of the voltage and current waveforms, using a limit device. The pictures should be taken with the temperature stabilized. Corresponding points are then read from each photo at a suitable number of time increments. Each pair of voltage and current values are multiplied together to give instant-

neous values of power. The results are plotted on linear graph paper, the number of squares within the curve counted, and the total divided by the number of squares along the time axis. The quotient is the average power dissipation. Oscilloscopes are available to perform these measurements and make the necessary calculations.

Substitution

This method is based upon substituting an easily measurable, smooth dc source for a complex waveform. A switching arrangement is provided which allows operating the load with the device under test, until it stabilizes

in temperature. Case temperature is monitored. By throwing the switch to the "test" position, the device under test is connected to a dc power supply, while another pole of the switch supplies the normal power to the load to keep it operating at full power level. The dc supply is adjusted so that the semiconductor case temperature remains approximately constant when the switch is thrown to each position for about 10 seconds. The dc voltage and current values are multiplied together to obtain average power. It is generally necessary that a Kelvin connection be used for the device voltage measurement.

APPENDIX A THERMAL RESISTANCE CONCEPTS

The basic equation for heat transfer under steady-state conditions is generally written as:

$$q = hA\Delta T \quad (1)$$

where q = rate of heat transfer or power dissipation (P_D)
 h = heat transfer coefficient,
 A = area involved in heat transfer,
 ΔT = temperature difference between regions of heat transfer.

However, electrical engineers generally find it easier to work in terms of thermal resistance, defined as the ratio of temperature to power. From Equation 1, thermal resistance, R_{θ} , is

$$R_{\theta} = \Delta T/q = 1/hA \quad (2)$$

The coefficient (h) depends upon the heat transfer mechanism used and various factors involved in that particular mechanism.

An analogy between Equation (2) and Ohm's Law is often made to form models of heat flow. Note that T could be thought of as a voltage thermal resistance corresponds to electrical resistance (R); and, power (q) is analogous to current (I). This gives rise to a basic thermal resistance model for a semiconductor as indicated by Figure A1.

The equivalent electrical circuit may be analyzed by using Kirchoff's Law and the following equation results:

$$T_J = P_D(R_{\theta JC} + R_{\theta CS} + R_{\theta SA}) + T_A \quad (3)$$

where T_J = junction temperature,
 P_D = power dissipation
 $R_{\theta JC}$ = semiconductor thermal resistance (junction to case),
 $R_{\theta CS}$ = interface thermal resistance (case to heatsink),
 $R_{\theta SA}$ = heatsink thermal resistance (heatsink to ambient),
 T_A = ambient temperature.

The thermal resistance junction to ambient is the sum of the individual components. Each component must be minimized if the lowest junction temperature is to result.

The value for the interface thermal resistance, $R_{\theta CS}$, may be significant compared to the other thermal-resistance terms. A proper mounting procedure can minimize $R_{\theta CS}$.

The thermal resistance of the heatsink is not absolutely constant; its thermal efficiency increases as ambient temperature increases and it is also affected by orientation of the sink. The thermal resistance of the semiconductor is also variable; it is a function of biasing and temperature. Semiconductor thermal resistance specifications are normally at conditions where current density is fairly uniform. In some applications such as in RF power amplifiers and short-pulse applications, current density is not uniform and localized heating in the semiconductor chip will be the controlling factor in determining power handling ability.

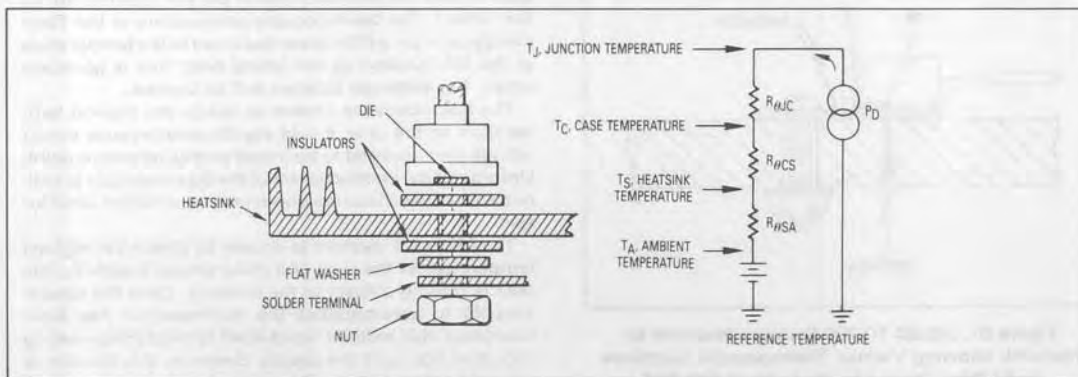

Figure A1. Basic Thermal Resistance Model Showing Thermal to Electrical Analogy for a Semiconductor

APPENDIX B MEASUREMENT OF INTERFACE THERMAL RESISTANCE

Measuring the interface thermal resistance $R_{\theta CS}$ appears deceptively simple. All that's apparently needed is a thermocouple on the semiconductor case, a thermocouple on the heatsink, and a means of applying and measuring DC power. However, $R_{\theta CS}$ is proportional to the amount of contact area between the surfaces and consequently is affected by surface flatness and finish and the amount of pressure on the surfaces. The fastening method may also be a factor. In addition, placement of the thermocouples can have a significant influence upon the results. Consequently, values for interface thermal resistance presented by different manufacturers are not in good agreement. Fastening methods and thermocouple locations are considered in this Appendix.

When fastening the test package in place with screws, thermal conduction may take place through the screws, for example, from the flange ear on a TO-3 package directly to the heatsink. This shunt path yields values which are artificially low for the insulation material and dependent upon screw head contact area and screw material. MIL-I-49456 allows screws to be used in tests for interface thermal resistance probably because it can be argued that this is "application oriented."

Thermalloy takes pains to insulate all possible shunt conduction paths in order to more accurately evaluate insulation materials. The Motorola fixture uses an insulated clamp arrangement to secure the package which also does not provide a conduction path.

As described previously, some packages, such as a TO-220, may be mounted with either a screw through the tab or a clip bearing on the plastic body. These two methods often yield different values for interface thermal resistance. Another discrepancy can occur if the top of the package is exposed to the ambient air where radiation and convection can take place. To avoid this, the package should be covered with insulating foam. It has been estimated that a 15 to 20% error in $R_{\theta CS}$ can be incurred from this source.

Another significant cause for measurement discrepancies is the placement of the thermocouple to measure

the semiconductor case temperature. Consider the TO-220 package shown in Figure B1. The mounting pressure at one end causes the other end — where the die is located — to lift off the mounting surface slightly. To improve contact, Motorola TO-220 Packages are slightly concave. Use of a spreader bar under the screw lessens the lifting, but some is inevitable with a package of this structure. Three thermocouple locations are shown:

a. The Motorola location is directly under the die reached through a hole in the heatsink. The thermocouple is held in place by a spring which forces the thermocouple into intimate contact with the bottom of the semi's case.

b. The JEDEC location is close to the die on the top surface of the package base reached through a blind hole drilled through the molded body. The thermocouple is swaged in place.

c. The Thermalloy location is on the top portion of the tab between the molded body and the mounting screw. The thermocouple is soldered into position.

Temperatures at the three locations are generally not the same. Consider the situation depicted in the figure. Because the only area of direct contact is around the mounting screw, nearly all the heat travels horizontally along the tab from the die to the contact area. Consequently, the temperature at the JEDEC location is hotter than at the Thermalloy location and the Motorola location is even hotter. Since junction-to-sink thermal resistance must be constant for a given test setup, the calculated junction-to-case thermal resistance values decrease and case-to-sink values increase as the "case" temperature thermocouple readings become warmer. Thus the choice of reference point for the "case" temperature is quite important.

There are examples where the relationship between the thermocouple temperatures are different from the previous situation. If a mica washer with grease is installed between the semiconductor package and the heatsink, tightening the screw will not bow the package; instead, the mica will be deformed. The primary heat conduction path is from the die through the mica to the heatsink. In this case, a small temperature drop will exist across the vertical dimension of the package mounting base so that the thermocouple at the EIA location will be the hottest. The thermocouple temperature at the Thermalloy location will be lower but close to the temperature at the EIA location as the lateral heat flow is generally small. The Motorola location will be coolest.

The EIA location is chosen to obtain the highest temperature on the case. It is of significance because power ratings are supposed to be based on this reference point. Unfortunately, the placement of the thermocouple is tedious and leaves the semiconductor in a condition unfit for sale.

The Motorola location is chosen to obtain the highest temperature of the case at a point where, hopefully, the case is making contact to the heatsink. Once the special heatsink to accommodate the thermocouple has been fabricated, this method lends itself to production testing and does not mark the device. However, this location is not easily accessible to the user.

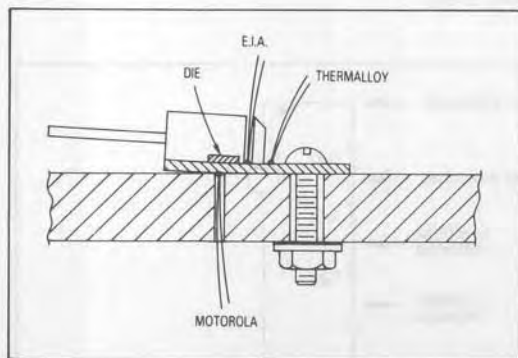

Figure B1. JEDEC TO-220 Package Mounted to Heatsink Showing Various Thermocouple Locations and Lifting Caused by Pressure at One End

The Thermalloy location is convenient and is often chosen by equipment manufacturers. However, it also blemishes the case and may yield results differing up to 1°C/W for a TO-220 package mounted to a heatsink without thermal grease and no insulator. This error is small when compared to the thermal resistance of heat dissipaters often used with this package, since power dissipation is usually a few watts. When compared to the specified junction-to-case values of some of the higher power semiconductors becoming available, however, the difference becomes significant and it is important that the semiconductor manufacturer and equipment manufacturer use the same reference point.

Another EIA method of establishing reference temper-

atures utilizes a soft copper washer (thermal grease is used) between the semiconductor package and the heatsink. The washer is flat to within 1 mil/inch, has a finish better than 63 μ -inch, and has an imbedded thermocouple near its center. This reference includes the interface resistance under nearly ideal conditions and is therefore application-oriented. It is also easy to use but has not become widely accepted.

A good way to improve confidence in the choice of case reference point is to also test for junction-to-case thermal resistance while testing for interface thermal resistance. If the junction-to-case values remain relatively constant as insulators are changed, torque varied, etc., then the case reference point is satisfactory.

APPENDIX C Sources of Accessories

Manufacturer	Joint Compound	Adhesives	Insulators						Heatsinks
			BeO	AlO ₂	Anodize	Mica	Plastic Film	Silicone Rubber	
Aavid Eng.	X	X	—	—	—	—	—	X	X
AHAM-TOR	—	—	—	—	—	—	—	—	X
Astrodynamicis	X	—	—	—	—	—	—	—	X
Delbert Blinn	—	—	X	—	X	X	X	X	X
IERC	X	—	—	—	—	—	—	—	X
Staver	—	—	—	—	—	—	—	—	X
Thermalloy	X	X	X	X	X	X	X	X	X
Tran-tec	—	—	X	X	X	X	—	X	X
Wakefield Eng.	X	X	X	—	X	—	—	X	X

Other sources for silicone rubber pads: Chomerics, Berquist

Suppliers Addresses

Aavid Engineering, Inc., 30 Cook Court, Laconia, New Hampshire 03246 (603) 524-4443

AHAM-TOR Heatsinks, 27901 Front Street, Rancho, California 92390 (714) 676-4151

Astro Dynamics, Inc., 2 Gill St., Woburn, Massachusetts 01801 (617) 935-4944

Berquist, 5300 Edina Industrial Blvd., Minneapolis, Minnesota 55435 (612) 835-2322

Chomerics, Inc., 16 Flagstone Drive, Hudson, New Hampshire 03051 1-800-633-8800

Delbert Blinn Company, P.O. Box 2007, Pomona, California 91769 (714) 629-3900

International Electronic Research Corporation, 135 West Magnolia Boulevard, Burbank, California 91502

(213) 849-2481

The Staver Company, Inc., 41-51 Saxon Avenue, Bay Shore, Long Island, New York 11706 (516) 666-8000

Thermalloy, Inc., P.O. Box 34829, 2021 West Valley View Lane, Dallas, Texas 75234 (214) 243-4321

Tran-tec Corporation, P.O. Box 1044, Columbus, Nebraska 68601 (402) 564-2748

Wakefield Engineering, Inc., Wakefield, Massachusetts 01880 (617) 245-5900

PACKAGE INDEX

PREFACE

When the JEDEC registration system for package outlines started in 1957, numbers were assigned sequentially whenever manufacturers wished to establish a package as an industry standard. As minor variations developed from these industry standards, either a new, non-related number was issued by JEDEC or manufacturers would attempt to relate the part to an industry standard via some appended description.

In an attempt to ease confusion, JEDEC established the present system in late 1968 in which new packages are assigned into a category, based on their general physical appearance. Differences between specific packages in a category are denoted by suffix letters. The older package

designations were re-registered to the new system as time permitted.

For example the venerable TO-3 has many variations. Can heights differ and it is available with 30, 40, 50, and 60 mil pins, with and without lugs. It is now classified in the TO-204 family. The TO-204AA conforms to the original outline for the TO-3 having 40 mil pins while the TO-204AE has 60 mil pins, for example.

The new numbers for the old parts really haven't caught on very well. It seems that the DO-4, DO-5 and TO-3 still convey sufficient meaning for general verbal communication.

Motorola Case Number	JEDEC Outline		Notes	Mounting Class	See Page	Motorola Case Number	JEDEC Outline		Notes	Mounting Class	See Page	Motorola Case Number	JEDEC Outline		Notes	Mounting Class	See Page
	Original System	Revised System					Original System	Revised System					Original System	Revised System			
001	TO-3	TO-204AA		Flange	9	211-11				Flange	9	337-02				Flange	9
003	TO-3		2	Flange	9	215-02				Flange	9	340		TO-218AC		Tab	11
009	TO-61	TO-210AC		Stud	8	221		TO-220AB		Tab	11	340A-02				Plastic	12
011	TO-3	TO-204AA		Flange	9	221C-02				Plastic	12	340B-03			Isolated TO-218	Plastic	12
011A	TO-3		2	Flange	9	221D-01			Isolated TO-220	Plastic	12	342-01				Flange	9
012	TO-3		2	Flange	9	235		TO-208	1	Stud	8	357B-01				Flange	9
036	TO-60	TO-210AB		Stud	8	235-03				Stud	8	361-01				Flange	9
042A	DO-5	DO-203AB		Stud	8	238		TO-208	1	Stud	8	368-01				Flange	9
044	DO-4	DO-203AA		Stud	8	239		TO-208		Stud	8	369-03		TO-251		Insertion	14
054	TO-3		2	Flange	9	244-04				Stud	8	369A-04		TO-252		Surface	13
056	DO-4			Stud	8	245	DO-4			Stud	8	373-01			Isolated	Flange	9
058	DO-5		2	Stud	8	257-01	DO-5			Stud	8	383-01			Isolated	Flange	10
61-03				Flange	9	263		TO-208		Stud	8	387-01		TO-254AA	Isolated 2	Tab	11
63-02	TO-64	TO-208AB		Stud	8	263-04				Stud	8	388A-01		TO-258AA	Isolated 2	Tab	11
63-03	TO-64	TO-2088AB		Stud	8	283	DO-4			Stud	8	744-02				Flange	9
077	TO-126	TO-225AA		Plastic	12	289		TO-209	1	Stud	8	744A-01				Flange	9
080	TO-66	TO-213AA		Flange	9	305-01				Stud	8	806-02			Isolated	Flange	9
086		TO-208	1	Stud	8	310-02				Pressfit	9	807-01			Isolated	Flange	9
086L		TO-298	1	Stud	8	311-01			Isolated	Stud	8	807-02			Isolated	Flange	9
144B-05				Stud	8	311-02				Pressfit	9	807A-01			Isolated	Flange	9
145A-09				Stud	8	311-02				Stud	8	808-01			Isolated	Flange	9
145A-10				Stud	8	314B-01				Tab	11	809-01			Isolated	Flange	9
145C	TO-232		1	Stud	8	314D-01				Tab	11	812-01			Isolated	Flange	9
157		DO-203	1	Stud	8	316-01				Flange	9	813-01			Isolated	Flange	9
160-03	TO-59	TO-210AA		Stud	8	319-04				Flange	9	814-01			Isolated	Flange	9
167		DO-203	1	Stud	8	328A-01				Flange	9	814A-01			Isolated	Flange	9
174-04				Pressfit	9	332-04				Stud	8	084B-01			Isolated	Flange	9
175-03				Stud	8	333-03				Flange	9	816-01			Isolated	Flange	9
197		TO-204AE		Flange	9	333A-01				Flange	9	819-01			Isolated	Flange	9
211-07				Flange	9	336-03				Flange	9	043-02	DO-21	DO-208AA		Pressfit	9
211-09				Flange	9												

Notes: 1. Would fit within this family outline if registered with JEDEC.
2. Not within all JEDEC dimensions.

Motorola reserves the right to make changes without further notice to any products herein to improve reliability, function or design. Motorola does not assume any liability arising out of the application or use of any product or circuit described herein; neither does it convey any license under its patent rights nor the rights of others. Motorola products are not authorized for use as components in life support devices or systems intended for surgical implant into the body or intended to support or sustain life. Buyer agrees to notify Motorola of any such intended end use whereupon Motorola shall determine availability and suitability of its product or products for the use intended. Motorola and (M) are registered trademarks of Motorola, Inc. Motorola, Inc. is an Equal Employment Opportunity/Affirmative Action Employer.

Literature Distribution Centers:

USA: Motorola Literature Distribution; P.O. Box 20912; Phoenix, Arizona 85036.

EUROPE: Motorola Ltd.; European Literature Center; 88 Tanners Drive, Blakelands Milton Keynes, MK145BP, England.

ASIA PACIFIC: Motorola Semiconductors H.K. Ltd.; P.O. Box 80300; Cheung Sha Wan Post Office; Kowloon Hong Kong.



MOTOROLA

AN1040

RR3-20