

Fast IC Power Transistor with Thermal Protection

National Semiconductor
Application Note 110



INTRODUCTION

Overload protection is perhaps most necessary in power circuitry. This is shown by recent trends in power transistor technology. Safe-area, voltage and current handling capability have been increased to limits far in excess of package power dissipation. In RF transistors, devices are now available and able to withstand badly mismatched loads without destruction. However, for anyone working with power transistors, they are still easily destroyed.

Since power circuitry, in many cases, drives other low level circuitry—such as a voltage regulator—protection is doubly important. Overloads that cause power transistor failure can result in the destruction of the entire circuit. This is because the common failure mode for power transistors is a short from collector to emitter—applying full voltage to the load. In the case of a voltage regulator, the raw supply voltage would be applied to the low level circuitry.

A new monolithic power transistor provides virtually absolute protection against any type of overload. Included on the chip are current limiting, safe area protection and thermal limiting. Current limiting controls the peak current through the chip to a safe level below the fusing current of the aluminum metallization. At high collector to emitter voltage the safe area limiting reduces the peak current to further protect the power transistor. If, under prolonged overload, power dissipation causes chip temperature to rise toward destructive levels, thermal limiting turns off the device keeping the devices at a safe temperature. The inclusion of thermal limiting, a feature not easily available in discrete circuitry makes this device especially attractive in applications where normal protective schemes are ineffective.

The device's high gain and fast response further reduce requirements of surrounding circuitry. As well as being used in linear applications, the IC can interface transistor-transistor logic or complementary-MOS logic to power loads without external devices. In fact, the input-current requirement of 3 microamperes is small enough for one CMOS gate to drive over 400 LM195's.

Besides high dc current gain, the IC has low input capacitance so it can be easily driven from high impedance sources—even at high frequencies. In a standard TO-3 power package, the monolithic structure ties the emitter, rather than the collector, to the case effectively boot-strapping the base-to-package capacitance. Additionally, connecting the emitter to the package is especially convenient for grounded emitter circuits.

The device is fully protected against any overload condition when it is used below the maximum voltage rating. The current-limiting circuitry restricts the power dissipation to 35 watts, 1.8 amperes are available at collector-to-emitter volt-

age of 17V decreasing to about 0.8 amperes at 40V. In reality, however, like standard transistors, power dissipation in actual use is limited by the size of the external heat sink.

Switching time is fast also. At 40V 25 Ohm load can be switched on or off in a relatively fast 500 ns. The internal planar double diffused monolithic transistors have an f_t of 200 MHz to 400 MHz. The limiting factor on overall speed is the protective and biasing circuitry around the output transistors. An important performance point is that no more than the normal 3 μ A base current is needed for fast switching.

To the designer, the LM195 acts like an ordinary power transistor, and its operation is almost identical to that of a standard power device. However, it provides almost absolute protection against any type of overload. And, since it is manufactured with standard seven-mask IC technology, the device is producible in large quantities at reasonable cost.

CIRCUIT DESIGN

Besides the protective features, the monolithic power transistor should function as closely to a discrete transistor as possible. Of course, due to the circuitry on the chip, there will be some differences.

Figure 1 shows a simplified schematic of the power transistor. A power NPN Darlington is driven by an input PNP. The PNP and output NPN's are biased by internal current source I_1 . The composite three transistors yield a total current gain in excess of 10^6 making it easy to drive the power transistors from high impedance sources. Unlike normal power transistors, the base current is negative, flowing out of the PNP. However, in most cases this is not a problem.

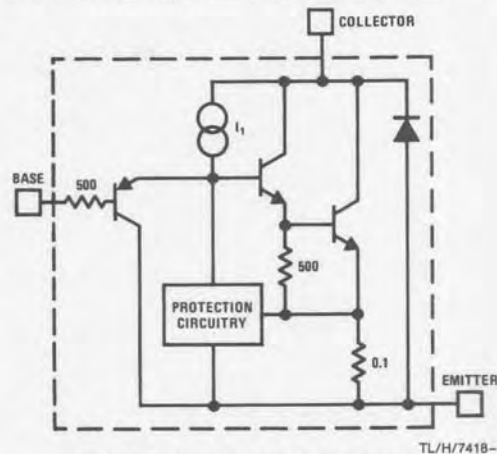

FIGURE 1. Simplified Circuit of the LM195

The input PNP transistor is made with standard IC processing and has a reverse base-emitter breakdown voltage in excess of 40V. This allows the power transistor to be driven from a stiff voltage source without damage due to excessive base current. At input voltages in excess of about 1V the input PNP becomes reverse biased and no current is drawn from the base lead. In fact it is possible for the base of the monolithic transistor to be driven with up to 40V even though the collector to emitter voltage is low. Further, the input PNP isolates the base drive from the protective circuitry insuring that even with high base drive the device will be protected. When the device is turned off current I_1 is shunted from the base of the NPN transistor by the PNP and appears at the emitter terminal. This sets the minimum load current to about 2 mA, not a severe restriction for a power transistor. Because of the PNP and I_1 , the power transistor turns "on" rather than "off" if the base is opened; however, most power circuits already include a base-emitter resistor to absorb leakage currents in present power transistors.

A schematic of the LM195 is shown in Figure 2. The circuitry is biased by four current sources comprised of Q4, Q7, Q8 and Q9. The operating current is set by Q5 and Q6 and is relatively independent of supply voltage. FET Q1 and R2 insure reliable starting of the bias circuitry while D1 clamps the output of the FET limiting the starting current at high supply voltage.

The output transistors Q19 and Q20 are driven from input PNP Q14. Current limiting independent of temperature changes is provided by Q21, Q16, and Q15. At high collector to emitter voltages the current limit decreases due to the voltage across R21 from D3, D4 and R20. The double emitter structure used on Q21 allows the power limiting to more closely approximate constant power curve rather than a

straight line decrease in output current as input voltage increases.

Transistor Q13 thermally limits the device by removing the base drive at high temperature. The actual temperature sensing is done by Q11 and Q12 with Q10 regulating the voltage across the sensors so thermal limit temperature remains independent of supply. As temperature increases, the collector current of Q11 increases while the V_{BE} of Q12 decreases. At about 170°C the Q12 turns on Q13 removing the base drive from the output transistors. Finally, C1, Q2 and Q3 boost operating currents during switching to obtain faster response time and Q17 and Q18 compensate for h_{fe} variations in the power devices.

PERFORMANCE

The new power transistor is packaged in a standard TO-3 transistor package making it compatible with standard power transistors. An added advantage of the monolithic structure is that the emitter is tied to the case rather than the collector. This allows the device to be connected directly to ground in collector output applications.

A photomicrograph of the LM195 is shown in Figure 3. More than half of the die area is needed for the output power transistor (Q20). Actually, the power transistor is many individual small transistors connected in parallel with a common collector. Partitioning the power device into small discrete areas improves power handling over a single large device. Firstly, the power device has ten base sections spread across the chip. Between the base diffusion are N+ collector contacts. Each section has its own emitter ballasting resistor to insure current sharing between sections. One of these resistors is used to sense the output current for current limiting.

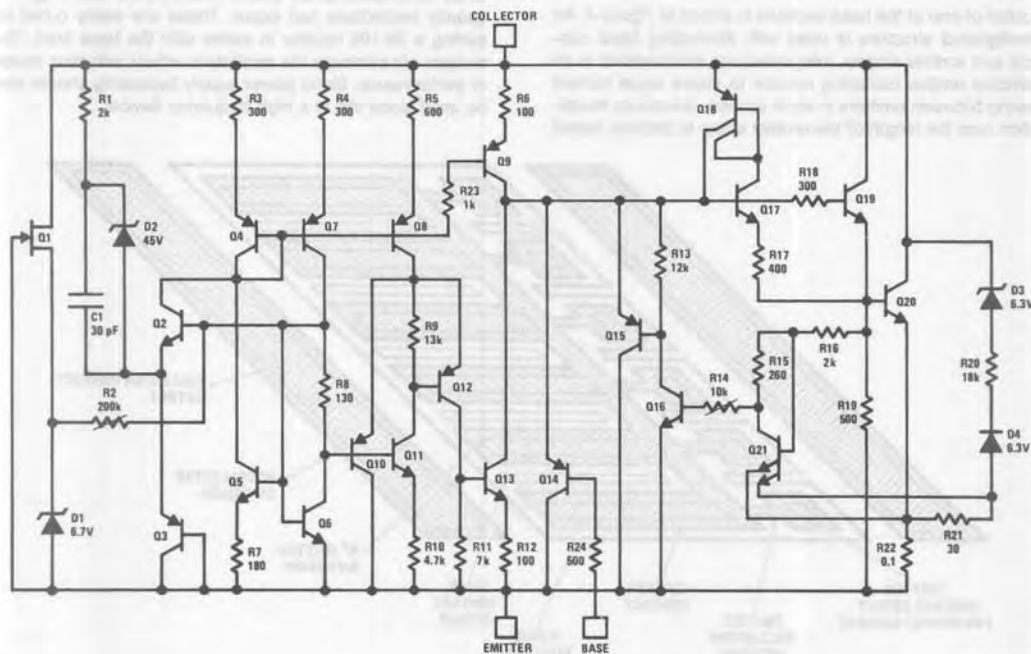

FIGURE 2. Schematic Diagram of the LM195

TL/H/7418-2

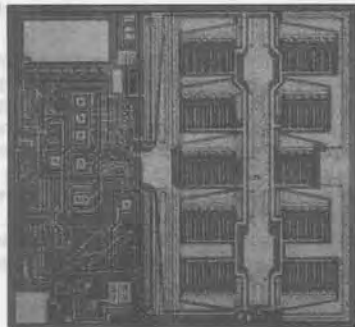

FIGURE 3. LM195 Chip

TL/H/7418-3

TABLE I. Typical Performance

Collector to Emitter Voltage	42V
Base to Emitter Voltage (max.)	42V
Peak Collector Current (internally limited)	1.8 amps
Reverse Base Emitter Voltage	20V
Base to Emitter Voltage ($I_C = 1.0$ amp)	0.9V
Base Current	3 μ A
Saturation Voltage	2V
Switching Time (turn on or turn off)	500 ns
Power Dissipation (internally limited)	35 watts
Thermal Limit Temperature	165°C
Maximum Operating Temperature	150°C
Thermal Resistance (Junction to Case)	2.3°C/W

A detail of one of the base sections is shown in *Figure 4*. An interdigitated structure is used with alternating base contacts and emitter stripes. Integrated into each emitter is an individual emitter ballasting resistor to insure equal current sharing between emitters in each section. Aluminum metallization runs the length of the emitter stripe to prevent lateral

voltage drop from debiasing a section of the stripe at high operating currents. All current in the stripe flows out through the small ballasting resistor where it is summed with the currents from the other stripes in the section. The partitioning in conjunction with the emitter resistor gives a power transistor with large safe-area and good power handling capability.

APPLICATIONS

With the full protection and high gain offered by this monolithic power transistor, circuit design is considerably simplified. The inclusion of thermal limiting, not normally available in discrete design allows the use of smaller heat sinks than with conventional protection circuitry. Further, circuits where protection of the power device is difficult—if not impossible—now cause no problems.

For example, with only current limiting, the power transistor heat sink must be designed to dissipate worst case overload power dissipation at maximum ambient temperature. When the power transistor is thermally limited, only normal power need be dissipated by the heat sink. During overload, the device is allowed to heat up and thermally limit, drastically reducing the size of the heat sink needed.

Switching circuits such as lamp drivers, solenoid drivers or switching regulators do not dissipate much power during normal operation and usually no heat sink is necessary. However, during overload, the full supply voltage times the maximum output current must be dissipated. Without a large heat sink standard power transistors are quickly destroyed.

Using this new device is easier than standard power transistors but a few precautions should be observed. About the only way the device can be destroyed is excessive collector to emitter voltage or improper power supply polarity. Sometimes when used as an emitter follower, low level high frequency oscillations can occur. These are easily cured inserting a 5k-10k resistor in series with the base lead. The resistor will eliminate the oscillation without effecting speed or performance. Good power supply bypassing should also be used since this is a high frequency device.

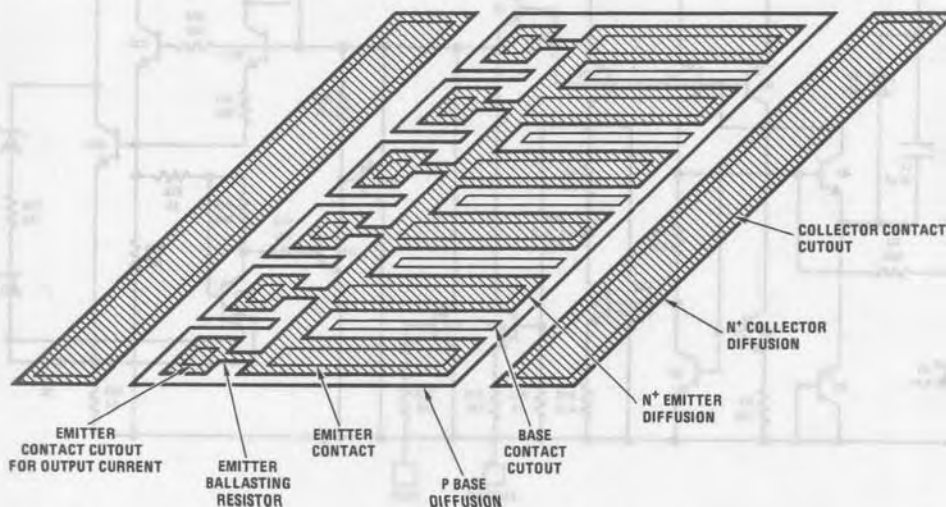
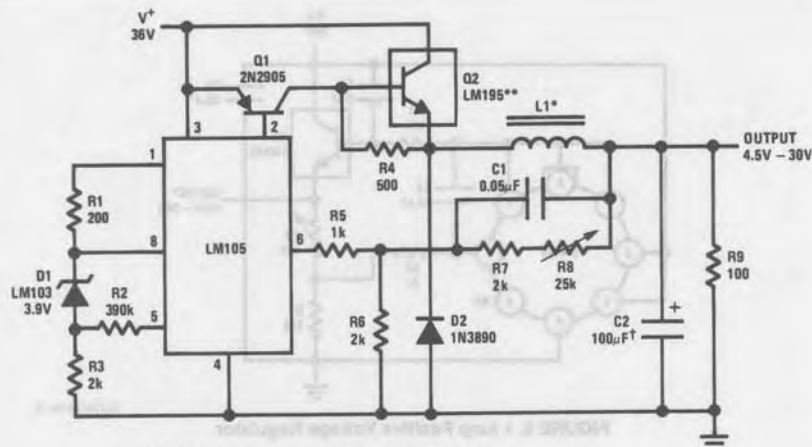

FIGURE 4. Detailed Structure of one Section of the Power Transistor

TL/H/7418-4



*Sixty turns wound on arnold type A-083081-2 core.

**Four devices in parallel.

†Solid tantalum.

TL/H/7418-5

FIGURE 5. 6 Amp Variable Output Switching Regulator

Figure 5 shows a 6 amp, variable output switching regulator for general purpose applications. An LM105 positive regulator is used as the amplifier-reference for the switching regulator. Positive feedback to induce switching is obtained from the LM105 at pin 1 through an LM103 diode. The positive feedback is applied to the internal amplifier at pin 5 and is independent of supply voltage. This forces the LM105 to drive the pass devices either "on" or "off," rather than linearly controlling their conduction. Negative feedback, delayed by L1 and the output capacitor, C2, causes the regulator to switch with the duty cycle automatically adjusting to provide a constant output. Four LM195's are used in parallel to obtain a 6 amp output since each device can only supply about 2 amps. Note that no ballasting resistors are needed for current sharing. When Q1 turns "on" all bases are pulled up to V⁺ and no base current flows in the LM195 transistors since the input PNP's are reverse biased.

A two terminal current/power limiter is shown in Figure 6. The base and collector are shorted—turning the power transistor on. If the load current exceeds 2 amps, the device current limits protecting the load. If the overload remains on, the device will thermal limit, further protecting itself and the load. In normal operation, only 2V appear across the device so high efficiency is realized and no heat sink is needed. Another method of protection would be to place the monolithic power transistor on a common heat sink with the devices to be protected. Overheating will then cause the LM195 to thermal limit protecting the rest of the circuitry.

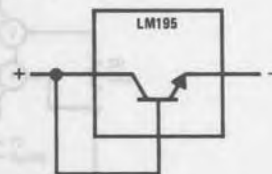

TL/H/7418-6

FIGURE 6. Two Terminal Current Limiter

The low base current make this power device suitable for many unique applications. Figure 7 shows a time delay circuit. Upon application of power or S1 closing, the load is energized. Capacitor C1 slowly charges toward V⁻ through R1. When the voltage across R1 decreases below about 0.8 volts the load is de-energized. Long delays can be obtained with small capacitor values since a high resistance can be used.

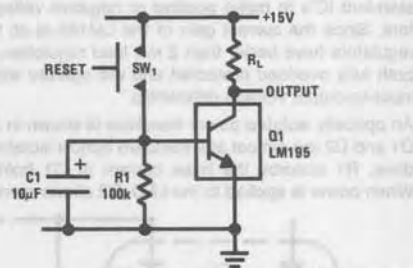

TL/H/7418-7

FIGURE 7. Time Delay Circuit

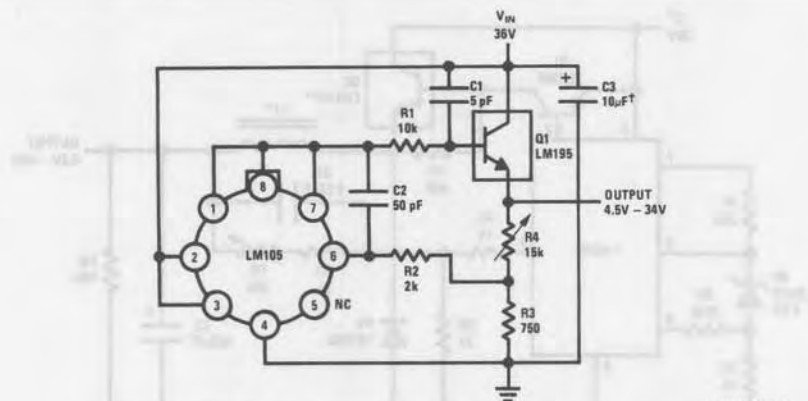

FIGURE 8. 1 Amp Positive Voltage Regulator

TL/H/7418-8

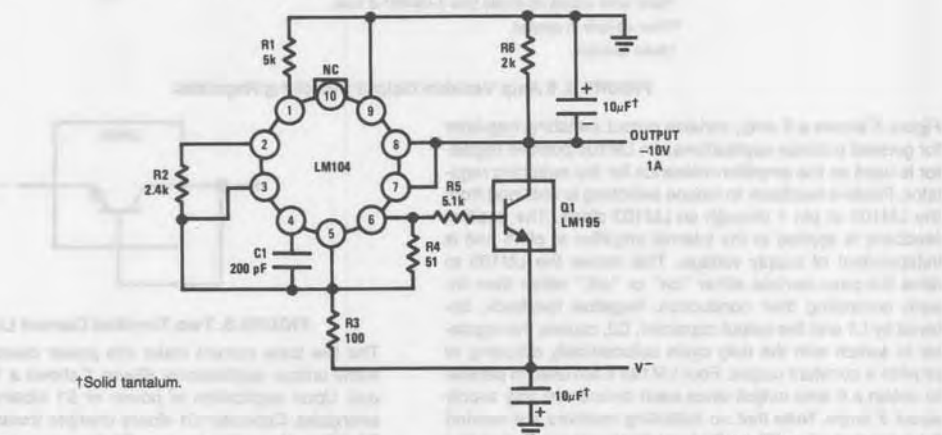
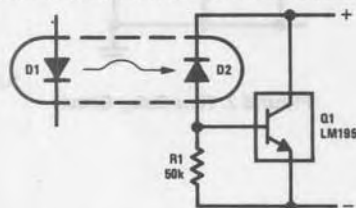

FIGURE 9. 1 Amp Negative Regulator

TL/H/7418-9

Figures 8 and 9 show how the LM195 can be used with standard IC's to make positive or negative voltage regulators. Since the current gain of the LM195 is so high, both regulators have better than 2 mV load regulation. They are both fully overload protected and will operate with only 2V input-to-output voltage differential.

An optically isolated power transistor is shown in Figure 10. D1 and D2 are almost any standard optical isolator. With no drive, R1 absorbs the base current of Q1 holding it off. When power is applied to the LED, D2 allows current to flow



TL/H/7418-10

FIGURE 10. Optically Isolated Power Transistor

from the collector to base. Less than 20 μ A from the diode is needed to turn the LM195 fully on.

An alternate connection for better ac response is to return the cathode of D2 to separate positive supply rather than the collector of Q1, as shown in Figure 11, eliminating the added collector to base capacitance of the diode. With this circuit a 40V 1 amp load can be switched in 500 ns. Of course, any photosensitive diode can be used instead of the opto-isolator to make a light activated switch.

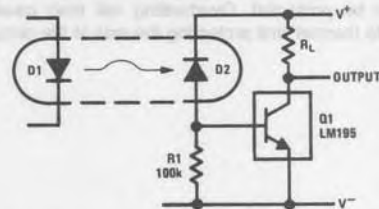

TL/H/7418-11

FIGURE 11. Fast Optically Isolated Switch

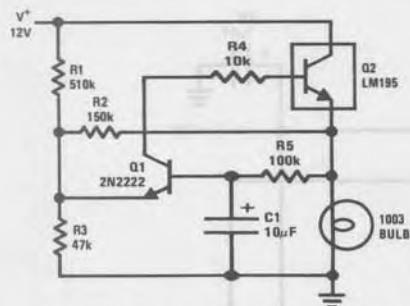
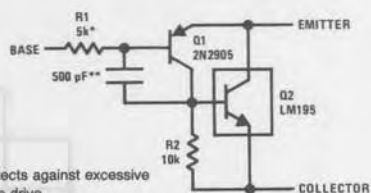

FIGURE 12. 1 Amp Lamp Flasher TL/H/7418-12



*Protects against excessive base drive.
**Needed for stability.

TL/H/7418-13

FIGURE 13. PNP Configuration for LM195

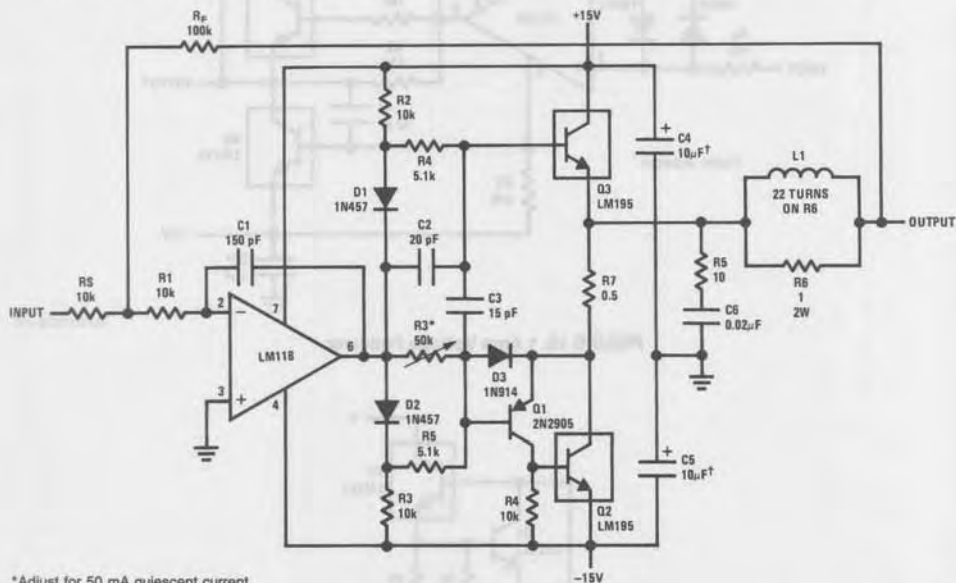

*Adjust for 50 mA quiescent current.
†Solid tantalum.

FIGURE 14. Power Op Amp

TL/H/7418-14

A power lamp flasher is shown in Figure 12. It is designed to flash a 12V bulb at about a once-per second rate. The reverse base current of Q2 provides biasing for Q1 eliminating the need for a resistor. Typically, a cold bulb can draw 8 times its normal operating current. Since the LM195 is current limited, high peak currents to the bulb are not experienced during turn-on. This prolongs bulb life as well as easing the load on the power supply.

Since no PNP equivalent of this device is available, it is advantageous to use the LM195 in a quasi-complementary configuration to simulate a power PNP. Figure 13 shows a quasi PNP made with an LM195. A low current PNP is used to drive the LM195 as the power output device. Resistor R1 protects against overdrive destroying the PNP and, in conjunction with C1, frequency compensates the loop against oscillations. Resistor R2 sets the operating current for the PNP and limits the collector current.

Figure 14 shows a power op amp with a quasi-complementary power output stage. Q1 and Q2 form the equivalent of a power PNP. The circuit is simply an op amp with a power output stage. As shown, the circuit is stable for almost any load. Better bandwidth can be obtained by decreasing C1 to 15 pF (to obtain 150 kHz full output response), but capaci-

tive loads can cause oscillation. If due to layout, the quasi-complementary loop oscillates, collector to base capacitance on Q1 will stabilize it. A simpler power op amp for up to 300 Hz operation is shown in Figure 15.

One of the more difficult circuit types to protect is a current regulator. Since the current is already fixed, normal protection doesn't work. Circuits to limit the voltage across the current regulator may allow excessive current to flow through the load. About the only protection method that protects both the regulator and the driven circuit is thermal limiting.

A 100 mA, two terminal regulator is shown in Figure 16. The circuit has low temperature coefficient and operates down to 3V. Once again, the reverse base current of the LM195 to bias the operating circuitry.

A 2N2222 is used to control the voltage across a current sensing resistor, R2 and diode D1, and therefore the current through it. The voltage across the sense network is the V_{BE} of the 2N2222 plus 1.2V from the LM113. In the sense network R2 sets the current while D1 compensates for the V_{BE} of the transistor. Resistor R1 sets the current through the LM113 to 0.6 mA.

