

# SUPER SNOOP

Great gadget ferrets out those hidden sounds of impending disaster in your ailing buggy.

By Alexander Prokop

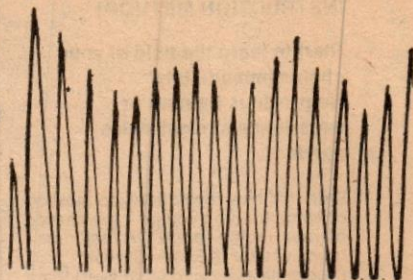

**A**re you a perfectionist? One of those guys that practically goes around the bend if your car has a well-concealed clatter, squeak, or rumble? Have you tried in vain to ferret out a little sound that to your sensitive ear bespeaks impending doom, only to find that neither you nor your local mechanical genius can put a finger on the buggy's hangup? Well, take heart, for the author understands, sympathizes, and has for you an answer to the source of your trepidations; a goody that'll check your transmission at 80 mph or your generator bearings at 30. It can tell you if your clutch is slipping on those five-G take-offs, or locate the source of a mysterious thump, clunk, squeak or rattle. Sound like the Super Snoop is for you? Well, read on, MacDuff.

**Heart Of Super Snoop.** The heart of the little beastie is a crystal transducer originally designed as a mouth-organ pickup. This pickup was found to be highly sensitive to vibrations of all sorts. As shown in the photos, the pickup is attached with a clamp

to the part or area you want to check out.

By virtue of picking up sounds only from the item to which it's attached, Super Snoop will tell you what's going on there without confusing you with extraneous noise. This selective pickup allows you to easily localize the source of the problem. Combined with a little training of the ear, the heap can be given a complete physical in a matter of a dozen or two minutes.

**Pickup Construction.** The first step in making Super Snoop is to visit your local hardware store and purchase a C-clamp as pictured in the photos. Most stores carry the bar handle type; however, if you can find one whose clamp screw and handle are one solid piece your task is simplified.

Now drill a hole as indicated with a No. 29 or .136 drill through the clamp and tap a (8-32) thread for the crystal mount. Next, if you have bar handle type clamp, wrap electrical tape around the handle so that it can't wiggle and generate extraneous noise in your pickup to confound your ear.



*The young lady is checking out her sports-car's transmission with the aid of Super Snoop. Here the transducer is attached right next to the gearshift lever with the C-clamp mount.*

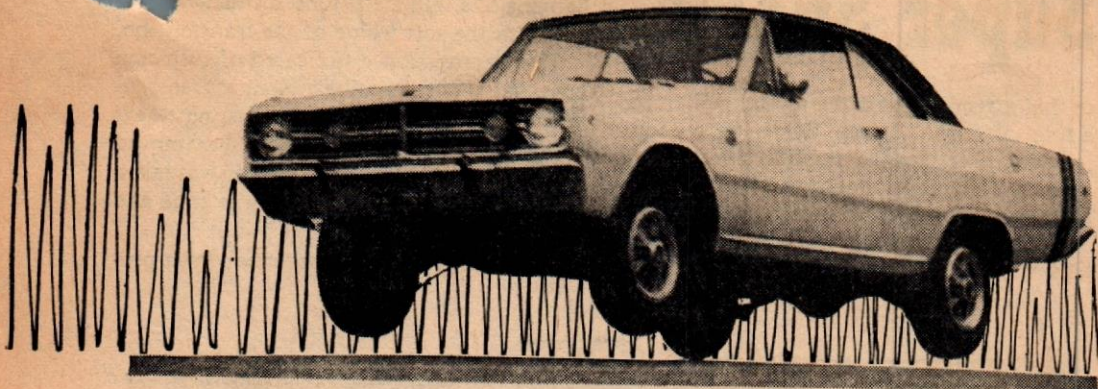

Add an 8-32 screw with a washer and the clamp is completed. The crystal transducer can be fastened to the clamp at any time with a screwdriver to complete the pickup. While the pickup is of a sturdy nature, care to prevent mechanical and water damage should be observed as with any sensitive device.

**Amplifier—Buy Or Make.** Construction of the amplifier should pose no problem as parts layout is not critical and requires no shielding other than the pickup cable.

For the softy who doesn't feel up to making his own amplifier, there are several ready-made, high-gain amplifier modules on the market that are ready to go with the addition of a battery, such as Radio Shack's Super High Gain Amp # 277-251. The amplifier will get knocked around a good deal and placing it in a firm plastic box with padding will insure trouble-free operation for years to come.

If you decide to build your own, the layout shown may be altered as box dimensions

demand. Use transistor sockets if you can, and take care to observe polarities on the electrolytic capacitors (C1, C2, C3) when wiring. When perf-board wiring is completed, install it in the plastic box, wire in the phono sockets, volume control, and switch. Then, power the rig with two 9-volt transistor radio batteries in series, and place a voltmeter from ground (B-) to the test point in the schematic diagram. Turn on the amplifier, and adjust potentiometer R8 for a reading of 2 volts on the voltmeter. This completes the only adjustment necessary.

Resistor R2 and capacitor C5 comprise a tone control which has been fixed for a nearly flat response to 15 kHz. By lowering the value of R2, the response will eliminate the higher frequencies. The entire sound spectrum is equally informative over the amplifier's range and a flat response is normally most desirable in tracking down and identifying sources of noise in autos and other applications.

Finally, splice eight feet of shielded cable

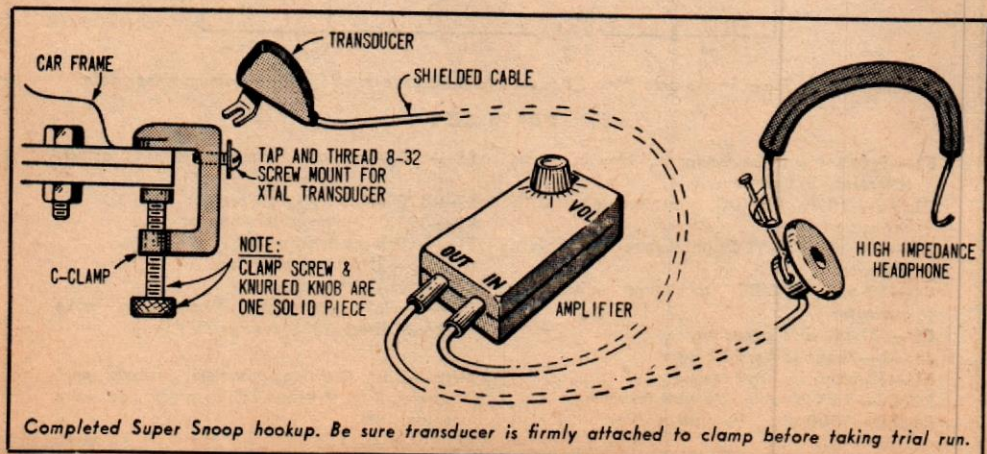

# Super Snoop

to that extending from the crystal pickup for a total of about 12 feet. Solder on a phone jack and plug into the amplifier's input, add a pair of 500-ohm phones and Super Snoop is ready for some super snooping.

**Case History.** Perhaps an actual application will best serve as an illustration. Re-

be a sharp ringing sound, not unlike the banging of a thin metal tube, distinctly different from the soft whine of the transmission.

The transmission was cleared of suspicion but what about the noise? A careful inspection revealed a dent in the exhaust pipe next to the transmission. The pipe was moved away as far as possible and the car was taken on a second run. The rumble was gone and with it all the worries.

**Auto Diagnosis.** A good trackdown pro-

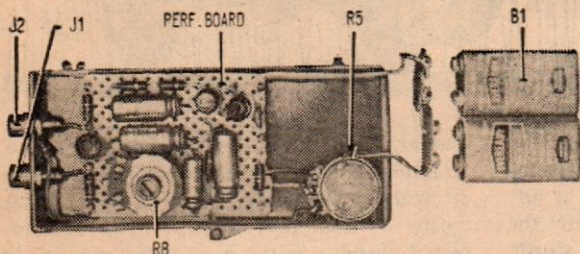

Perf-board construction of Super Snoop's amplifier speeds assembly and simplifies layout. Parts arrangement isn't critical and can be modified to suit individual preference.

cently, a '59 Buick Le Sabre produced a deep rumbling sound from under the floor when accelerating but otherwise ran quietly. The first suspect was the transmission. Placing the C-clamp pickup on the immediate frame supporting the transmission, the subsequent test run revealed the rumble heard inside to

cedure is to place the pickup on the frame near a suspected noise to obtain a better idea of its position after analyzing its sound.

Repeat this process until the offending part is identified. With a little practice and careful interpretation, Super Snoop will  
(Continued on page 109)

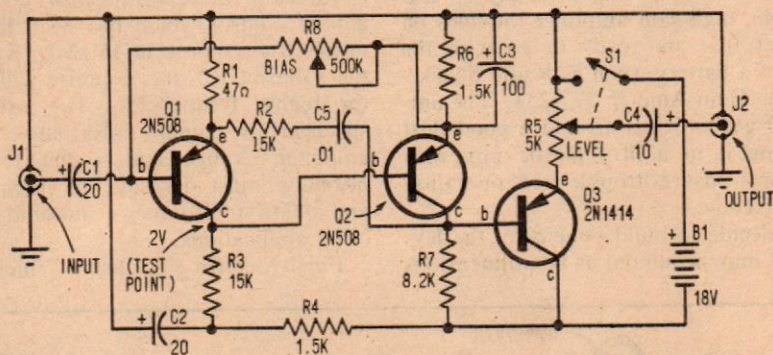

Schematic of Super Snoop amplifier. R8 is used to set bias level of Q1 for maximum linear gain.

## PARTS LIST

- B1—9-volt transistor batteries, two in series (Eveready 216 or equiv.)
- C1, C2—20 $\mu$ F, 20-VDC miniature electrolytic capacitor
- C3—100- $\mu$ F, 20-VDC miniature electrolytic capacitor
- C4—10- $\mu$ F, 15-VDC miniature electrolytic capacitor
- C5—.01- $\mu$ F, disc capacitor
- J1, J2—Phono jacks, RCA type
- R1—47-ohm, 1/2-watt resistor
- R2, R3—15,000-ohm, 1/2-watt resistors
- R4, R6—1500-ohm, 1/2-watt resistor

- R5—5000-ohm potentiometer (with S1 attached)
- R7—8200-ohm, 1/2-watt resistor
- R8—500,000-ohm potentiometer
- S1—Switch mounted on R5
- Q1, Q2—2N508 transistors
- Q3—2N1414 transistor
- X1—Crystal transducer, "harmonica mike" (Radio Shack 33-115 or equiv.)

Misc.—3-in. C-clamp, transistor sockets, perf-board, 8-ft. shielded cable, plastic box, wire, solder, etc.

## Super Snoop

*Continued from page 32*

prove to be a valuable aid in automobile and mechanical diagnosis.

A few points on safety should be observed and remembered. When tracing those squeaks or merely listening to your transmission switch gears, take care that the pickup cable is safely clear of moving parts capable of snagging it on the road and producing a dangerous situation by distracting your attention from driving. Use tape to hold the cable secure to the car body and areas where the cable cannot be strung through.

Similarly, when listening in the phones, keep in mind that a little recognized but important driving aid is removed—your hearing. So be cautious! The best safety measure is to let a friend drive and you can listen with a great deal more attention.

**Wide World Of Super Snoop.** Super Snoop can be used to detect worn brakes, frozen bearings, chipped gears, and a variety of other problems. It can also be used for listening to walls in 007 fashion; just place the pickup on any attachable wall-framing such as a door jamb, and conversations from the other side are easily monitored. Plaster walls, as far as sound sensitivity is concerned, are the best type of walls. If there is no framing on the wall, remove the transducer from the C-clamp and tape it to the wall. This method may be better in some cases for picking up conversations.

Finally, one last application of Super Snoop is its use in producing sound effects, such as water running through the pipes, marbles being dropped in empty metal pails, or salt being poured onto a card table. The possibilities are endless, and the results make Super Snoop a worthwhile addition to anybody's family. Happy snooping! ■