

CASE & CHASSIS

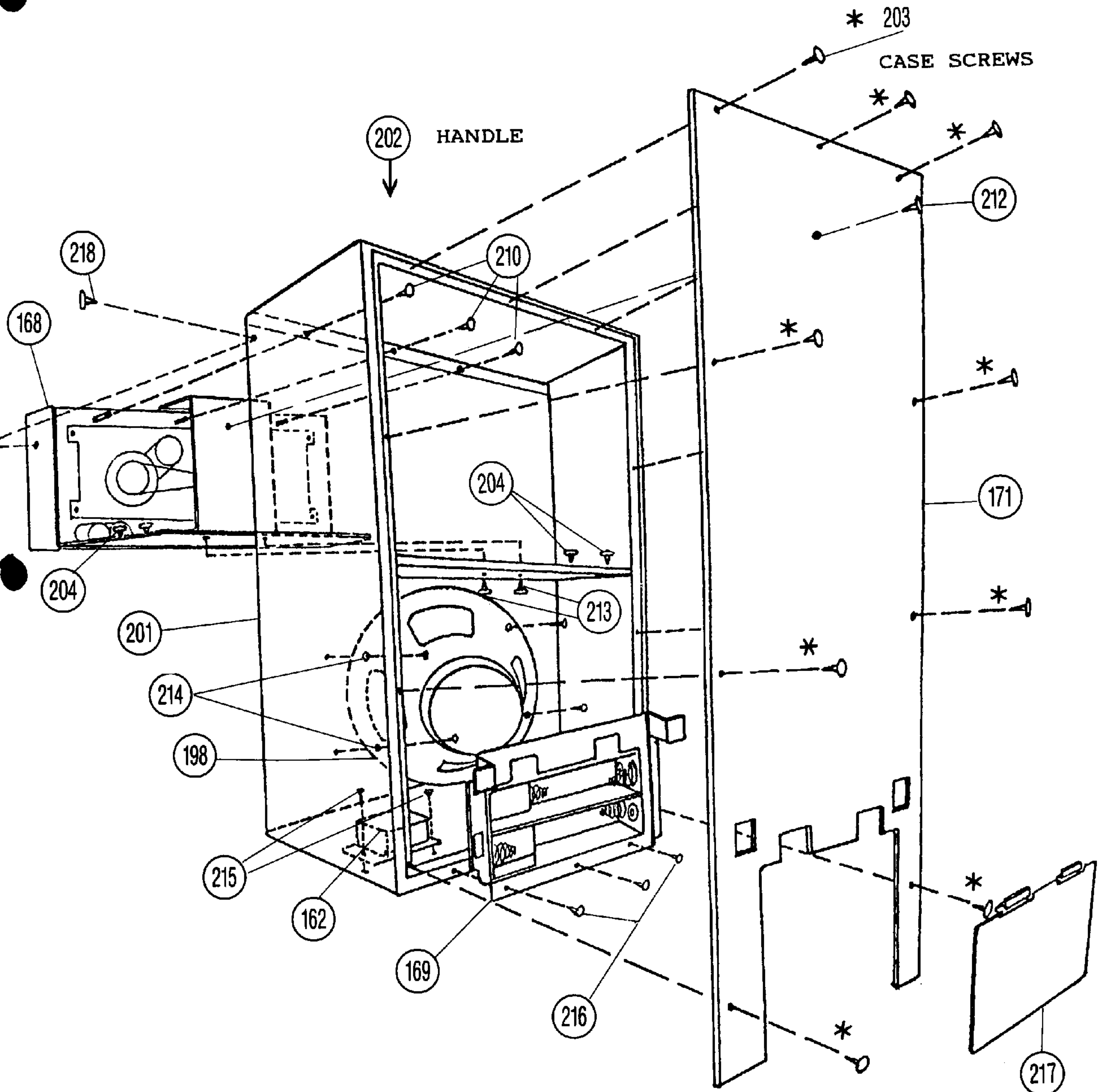

MODEL # 2485C

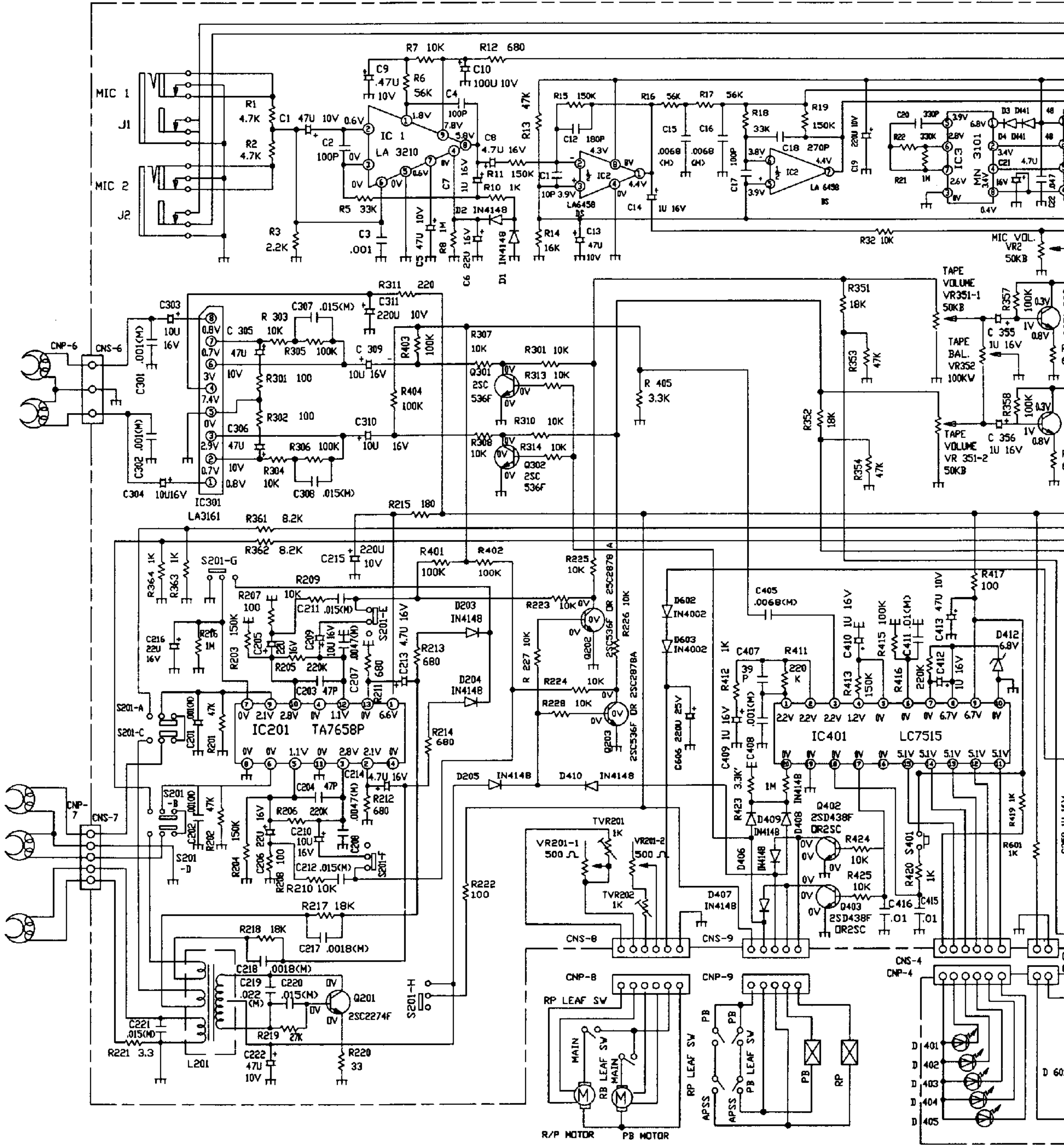

SCHEMATIC DIAGRAM

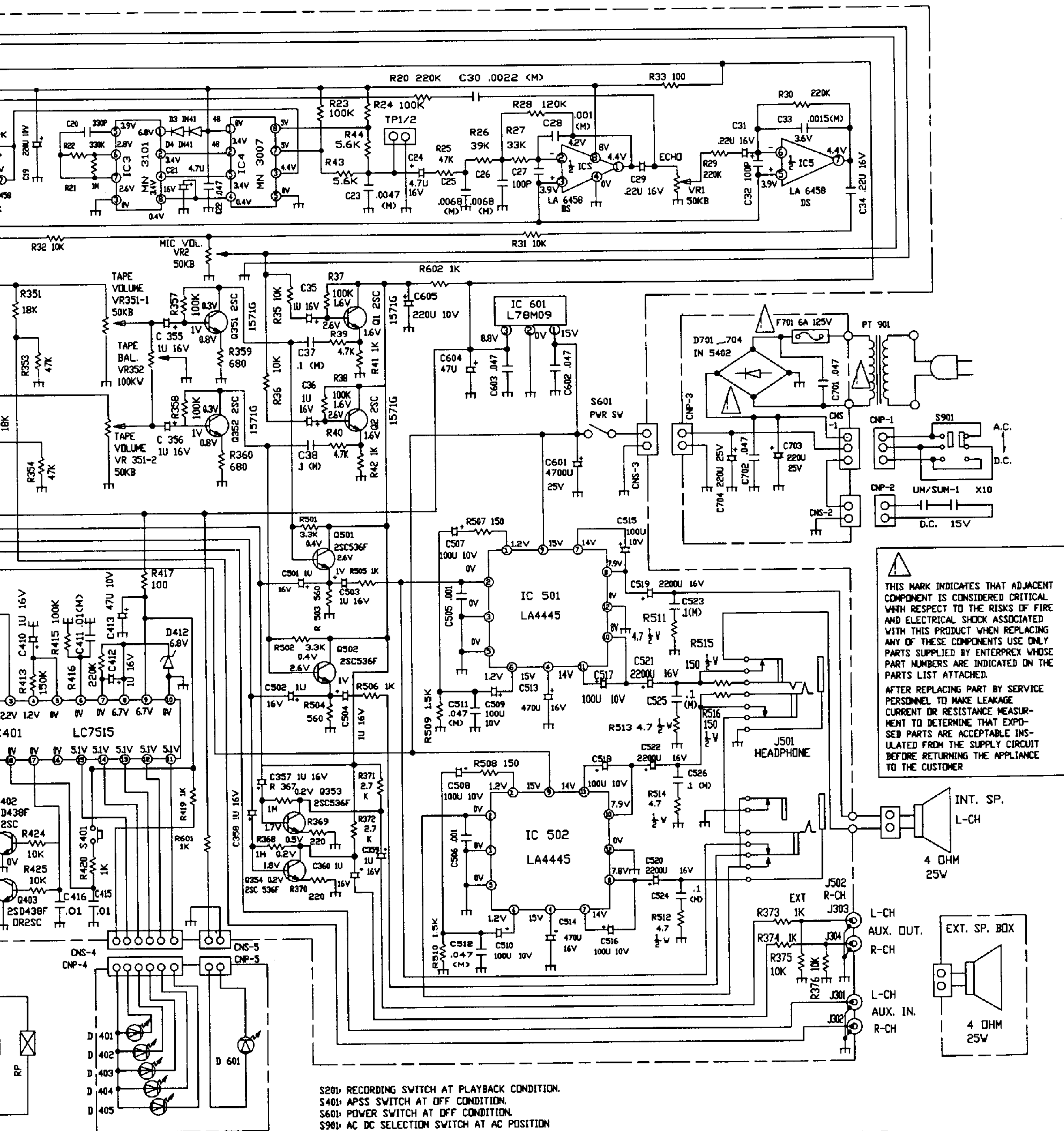

- S201: RECORDING SWITCH AT PLAYBACK CONDITION.
- S401: APSS SWITCH AT OFF CONDITION.
- S601: POWER SWITCH AT OFF CONDITION.
- S901: AC DC SELECTION SWITCH AT AC POSITION
- LEAF SW: A. RP DECK MAIN LEAF SW
- B. PB DECK MAIN LEAF SW
- LEAF SW: A. RP DECK PLAY BACK LEAF SW
- B. PB DECK PLAY BACK LEAF SW
- LEAF SW: A. RP DECK F.FWD & REV LEAF SW
- B. PB DECK F.FWD & REV LEAF SW

MODEL 2485C

PLAY TRANSPORT

RECORD TRANSPORT

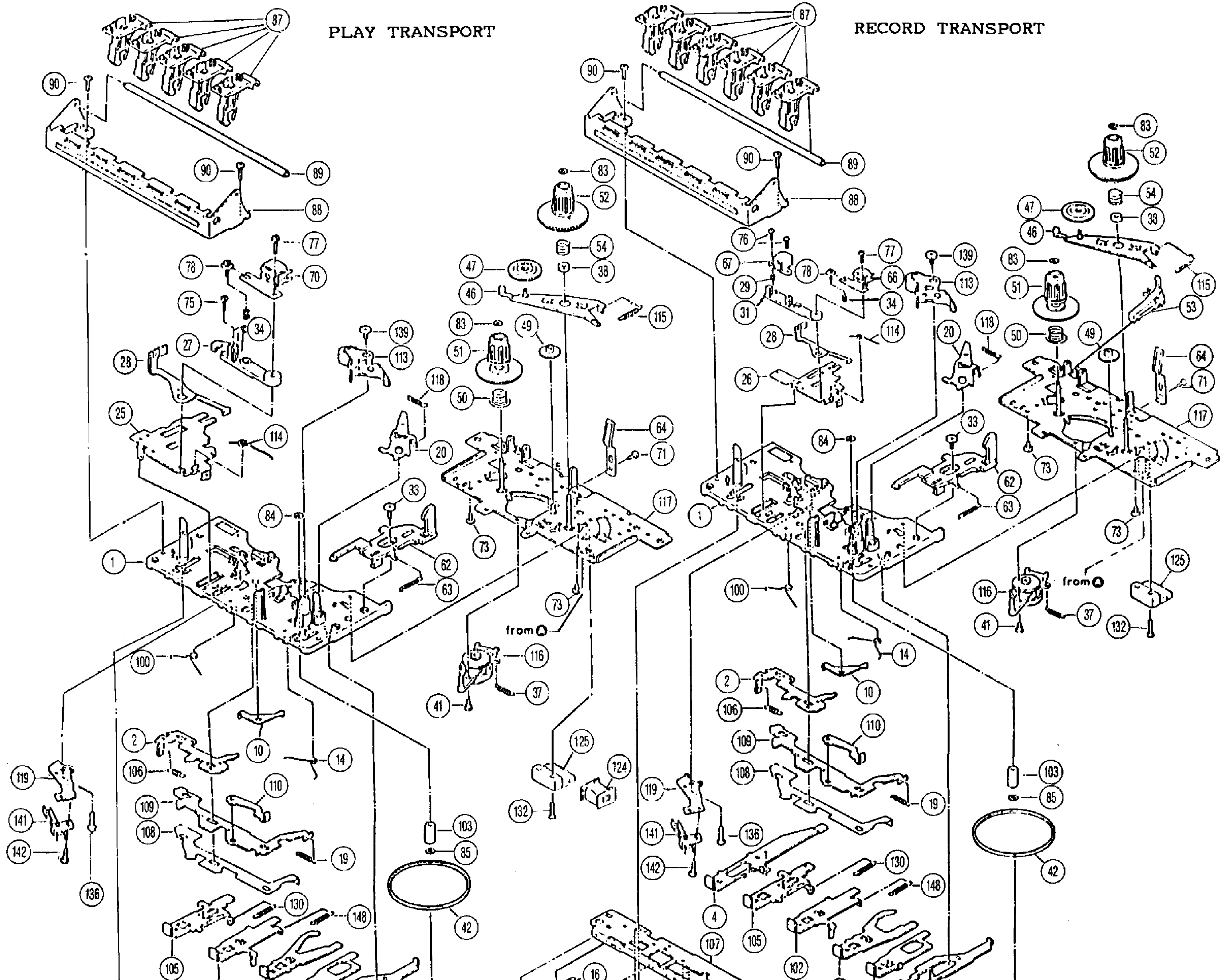

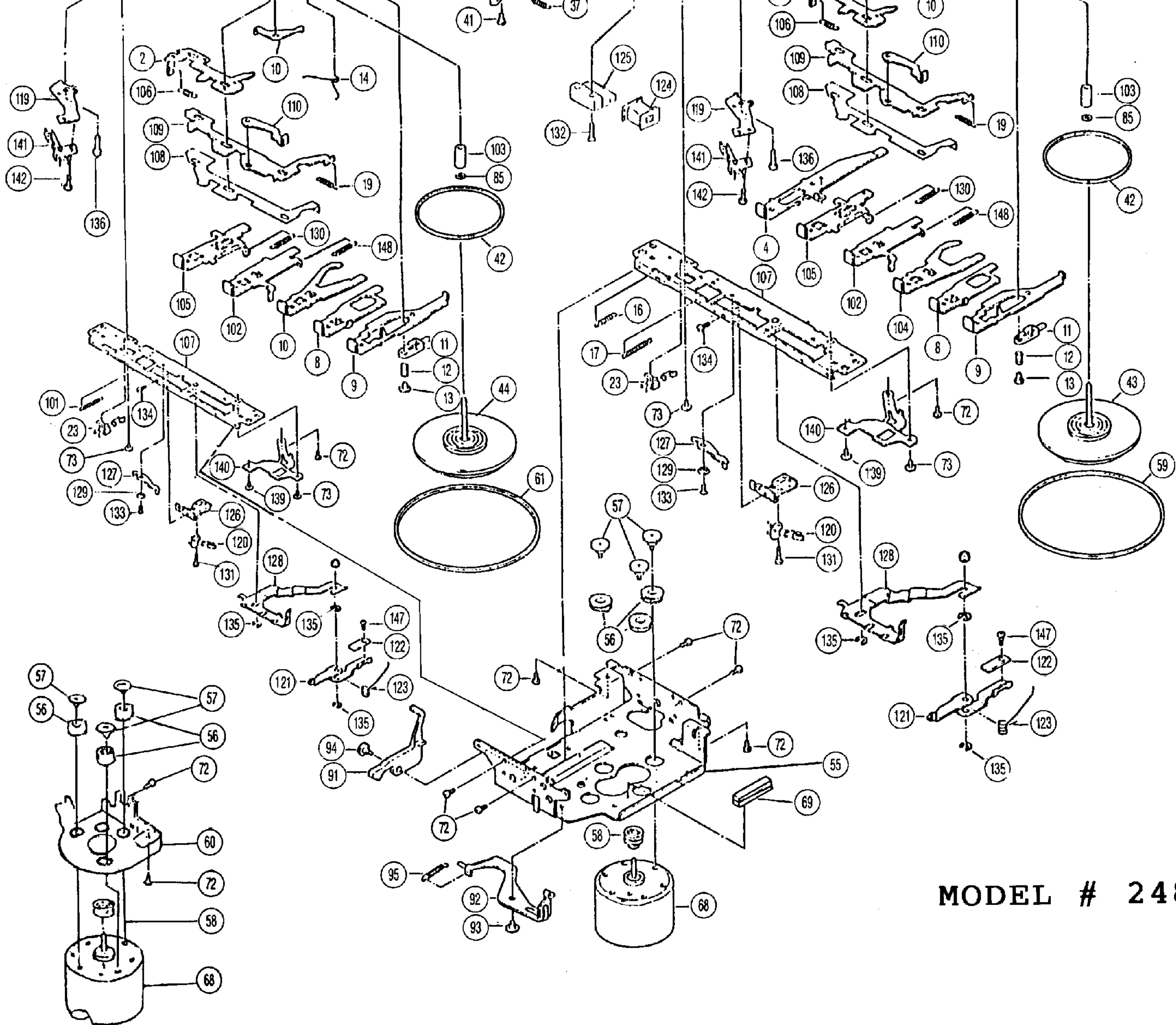

MODEL # 2485C