

This Manual Also Covers Model 973
Executive Radio-Phonograph

Service Manual

THE FISHER®

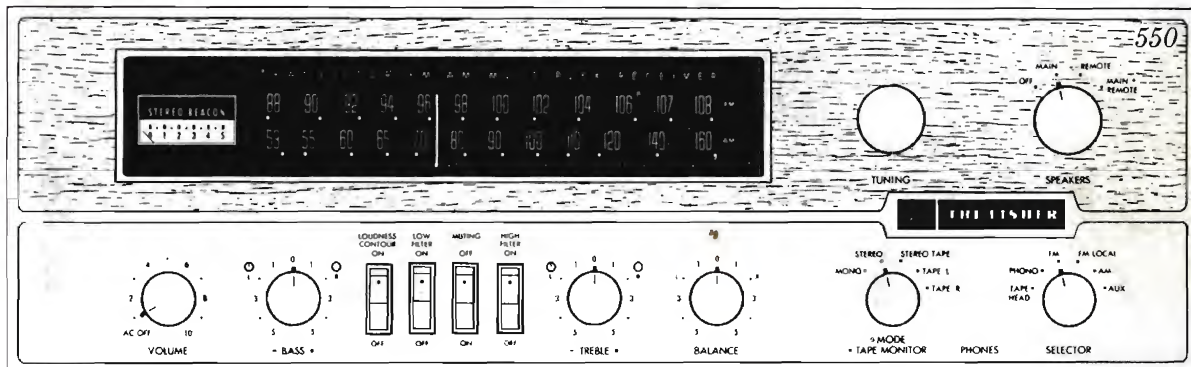

550-T™

CHASSIS SERIAL NUMBERS
BEGINNING 10001

PRICE \$1.00

FISHER RADIO CORPORATION • 11-40 45th ROAD • LONG ISLAND CITY, N.Y. 11101

CAUTION: This is a FISHER precision high-fidelity instrument. It should be serviced only by qualified personnel — trained in the repair of transistor equipment and printed circuitry.

TEST EQUIPMENT REQUIRED

The following are needed to completely test and align modern high-fidelity instruments such as amplifiers, tuners and receivers.

Vacuum-Tube Voltohmmeter (100-mV DC scale)	10.7-MHz Sweep Generator
Audio Vacuum-Tube Voltmeter (10-mV AC scale)	455-kHz Sweep Generator
Oscilloscope (Flat to 100 kHz Minimum)	Line Voltage Autotransformer or Voltage Regulator
Audio (Sine-Wave) Generator	2 — Load Resistors, 4 or 8 Ohm, 50 Watt
Intermodulation Distortion Analyzer	2 — Full Range Speakers for Listening Tests
Harmonic Distortion Analyzer	Stereo Source — Turntable or Tape Recorder for Listening Tests
AM/FM Signal Generator	Soldering Iron with Small Tip
Multiplex Generator (preferably with RF output — FISHER Model 300 or equal)	Fully Insulated from Power Line
	Suction Desoldering Tool

PRECAUTIONS

Many of these items are included just as a reminder—they are normal procedures for experienced technicians. Short-cuts can be taken but often they cause additional damage — to transistors, circuit components or the printed-circuit board.

Soldering—A well-tinned, hot, clean soldering iron tip will make it easier to solder without damage to the printed-circuit board or the many circuit components mounted on it. It is not the wattage of the iron that counts — it is the heat available at the tip. Some 50-watt irons reach temperatures of 1,000° F — others will hardly melt solder. Small-diameter tips should be used for single solder connections — larger pyramid and chisel tips are needed for larger areas.

- When removing defective resistors, capacitors, etc., the leads should be cut as close to the body of the circuit component as possible. (If the part is not being returned for in-warranty factory replacement it may be cut in half — with diagonal-cutting pliers — to make removal easier.)

- Special de-soldering tips are made for unsoldering multiple-terminal units like IF transformers and electrolytic capacitors. By unsoldering all terminals at the same time the part can be removed with little chance of breaking the printed-circuit board.

- Always disconnect the chassis from the power line when soldering. Turning the power switch OFF is not enough. Power-line leakage paths, through the heating element, can destroy transistors.

Transistors—Never attempt to do any work on the transistor amplifiers without first disconnecting the AC linecord and waiting until the power supply filter-capacitors have discharged.

- Guard against shorts — it takes only an instant for a base-to-collector short to destroy that transistor and possibly others direct-coupled to it. (In the time it takes for a dropped machine screw, washer or even the screwdriver, to glance off a pair of socket terminals (or between a terminal and the chassis) a transistor can be ruined.)

- DO NOT bias the base of any transistor to, or near, the same voltage applied to its collector.

- DO NOT use an ohmmeter for testing transistors. The voltage applied through the test probes may be higher than the base-emitter breakdown voltage of the transistor.

Output Stage and Driver — Replacements for output and

driver transistors, if necessary, must be made from the same beta group as the original type. The beta group is indicated by a colored dot on the mounting flange of the transistor. Be sure to include this information, when ordering replacement transistors.

- If one output transistor burns out (open or shorts), always remove ALL output transistors in that channel and check the bias adjustment, the control and other parts in the network with an ohmmeter before inserting a new transistor. All output transistors in one channel will be destroyed if the base-biasing circuit is open on the emitter end.

- When mounting a replacement power transistor be sure the bottom of the flange, the mica insulator and the surface of the heat sink are free of foreign matter. Dust and grit can prevent perfect contact reducing heat transfer to the heat sink. Metallic particles can puncture the insulator and cause shorts — ruining the transistor.

- Silicone grease must be used between the transistor and the mica insulator and between the mica and the heat sink for best heat conduction. (Use Dow-Corning DC-3 or C20194 or equivalent compounds made for power transistor heat conduction.)

- Use care when making connections to speakers and output terminals. Any frayed wire ends can cause shorts that may burn out the output transistors — they are direct-coupled to the speakers. To reduce the possibility of shorts at the speakers, lugs should be used on the exposed ends or at least the ends of the stranded wires should be tinned to prevent frayed wire ends. The current in the speakers and output circuitry is quite high. Poor contacts or small size wire can cause power losses in the speaker system. Use 14 or 16 AWG for long runs of speaker wiring.

Voltage Measurements—Voltage measurements are made with the line voltage adjusted to 117 volts and all readings are $\pm 10\%$. All voltages are DC, measured with a VTVM to ground, with no signal input unless otherwise noted. indicates 1-kHz audio voltages, measured with an audio AC VTVM to ground at various points from the phono input to the power amplifier output.

Alignment Procedures — Replacement of transistors and components in the front end, IF amplifier and multiplex decoder will normally not require realignment of these circuits. Realignment of these circuits, unless absolutely necessary, is not recommended. Do not attempt a realignment unless the required test equipment is available and the alignment procedure is thoroughly understood.

BECAUSE ITS PRODUCTS ARE SUBJECT TO CONTINUOUS IMPROVEMENT, FISHER RADIO CORPORATION RESERVES THE RIGHT TO MODIFY ANY DESIGN OR SPECIFICATION WITHOUT NOTICE AND WITHOUT INCURRING ANY OBLIGATION.

SERVICE PROCEDURES

DIAL STRINGING

- (1) Disconnect AC power cord. Remove the screws which hold the top cover to the chassis and lift off the top cover.
- (2) Gently pull all knobs off the front panel control shafts. Remove the hex nuts from the control shafts and lift off the front panel.
- (3) Remove the dial pointer from the dial cord.
- (4) Lift out the left dial glass lamp and remove the screw holding the left side of the dial glass panel.
- (5) Remove the two screws holding the right side of the dial glass panel.
- (6) Pull dial glass panel towards the left and tilt the panel down as far as the leads allow.
- (7) Rotate the tuning capacitor drive drum to its maximum counterclockwise position.
- (8) Tie end of dial cord to one end of small spring. Fasten spring to top right ear inside drive drum (Figure 1).
- (9) Run the dial cord through the slot in the rim of the drive drum and set in the underside of groove 1 (see side view).
- (10) Pull dial cord taut and wrap 1½ turns around the fly-wheel shaft.
- (11) Rotate the drive drum to its maximum clockwise position, allowing the dial cord to follow the grooves in the drum (Figure 2). Keep the dial cord taut during this procedure.
- (12) Guide the dial cord over the top of the drive drum and place it in groove 3 (see top view).
- (13) Run the dial cord through the slot in the drive drum and bring it under and around the beveled washer. Pull the dial cord taut until the spring stretches open. Tighten the machine screw to hold the dial cord under the washer.
- (14) Rotate the drive drum to its maximum counterclockwise position (Figure 3).
- (15) Run the loose end of the dial cord out through the slot in the drive drum and place it in groove 3 (see side view). Guide the dial cord around pulleys A and B.
- (16) Rotate the drive drum to its maximum clockwise position (Figure 4). Keep the dial cord taut during this procedure.
- (17) Guide the dial cord under the drive drum and into the last groove (see top view). Bring the dial cord up and around groove 6 and into the slot in the drive drum.

NOTE: Check that there is an empty groove between this turn and the next to last turn of dial cord on the drive drum.

- (18) Loosen the machine screw. Pull the dial cord taut until the spring tab lifts off the bottom of the cutout in the panel. Loosen the machine screw, place the cord under the beveled washer and retighten the screw.

CAUTION: Do not disturb the dial cord already under the washer.

- (19) Replace the dial glass panel using the reverse of Steps 4, 5, and 6.
- (20) Place the dial cord over and under the tabs on the rear of the dial pointer. Place the dial pointer on the top of the dial glass panel.
- (21) Replace the top cover and secure with the screws removed previously.
- (22) Replace the front panel and secure with the hex nuts removed previously. Replace the knobs on the control shafts.

REPLACING DIAL LAMPS

- (1) Disconnect AC power cord.
- (2) Gently pull all knobs off the front panel control shafts. Remove the hex nuts from the control shafts and lift off the front panel.
- (3) Snap out the defective lamp from the spring clip. Place

the new lamp in the socket making sure that the unpainted side of the lamp faces the edge of the dial glass.

- (4) Replace the front panel and secure with the hex nuts removed previously. Replace the knobs on the control shafts.

REPLACING METER AND STEREO BEACON LAMPS

- (1) Disconnect AC power cord.
- (2) Remove the screws which hold the top cover to the chassis and lift off the top cover.
- (3) Gently pry the lamp reflector shield off the top rear of the meter.
- (4) Gently pull the four wires off the pins on the top rear of the meter. Label each wire with its associated pin location to make replacement easier later.
- (5) Loosen the two nuts which hold the meter spring. Lift the compartmented lamp assembly out from under the meter spring. Place the new lamp assembly under the meter spring and line up the holes on the bottom with the projections on the rear of the meter. Tighten the two nuts which hold the meter spring.

NOTE: The lamp assembly must be replaced as a complete unit to insure proper illumination levels.

- (6) Replace the lamp reflector shield on the top rear of the meter.
- (7) Carefully insert the terminal connector at the end of the four wires removed previously on their associated pins at the top rear of the meter.
- (8) Replace the top cover on the chassis and secure with the screws removed previously.

CLEANING DIAL GLASS

- (1) Disconnect AC power cord.
- (2) Gently pull all knobs off the front panel control shafts. Remove the hex nuts from the control shafts and lift off the front panel.
- (3) If there are foam-cushion strips located at the ends of the dial glass, carefully remove them.
- (4) Loosen the screws which hold the retaining clips to the dial glass. Swing the clips aside and lift off the dial glass.
- (5) Remove dust with a dry cloth. If you wish to clean more thoroughly, use only plain lukewarm water; any stronger cleaning agent may damage the markings on the glass.
- (6) Replace the dial glass and position it down and towards the left of the chassis front. Swing the retaining clips back into place and tighten the retaining-clip screws. Replace the foam-cushion strips, if removed previously.
- (7) Replace the front panel and secure with the hex nuts removed previously. Replace the knobs on the control shafts.

CLEANING FRONT PANEL

WARNING: Use only plain lukewarm water and a freshly laundered, soft lint-free cloth to clean the front control panel.

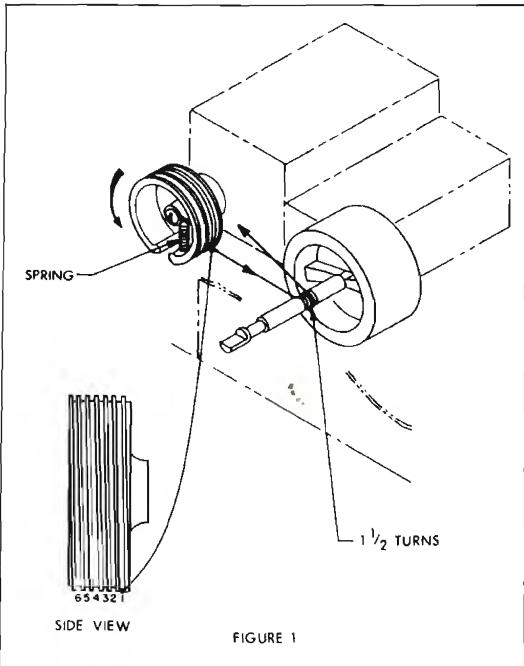
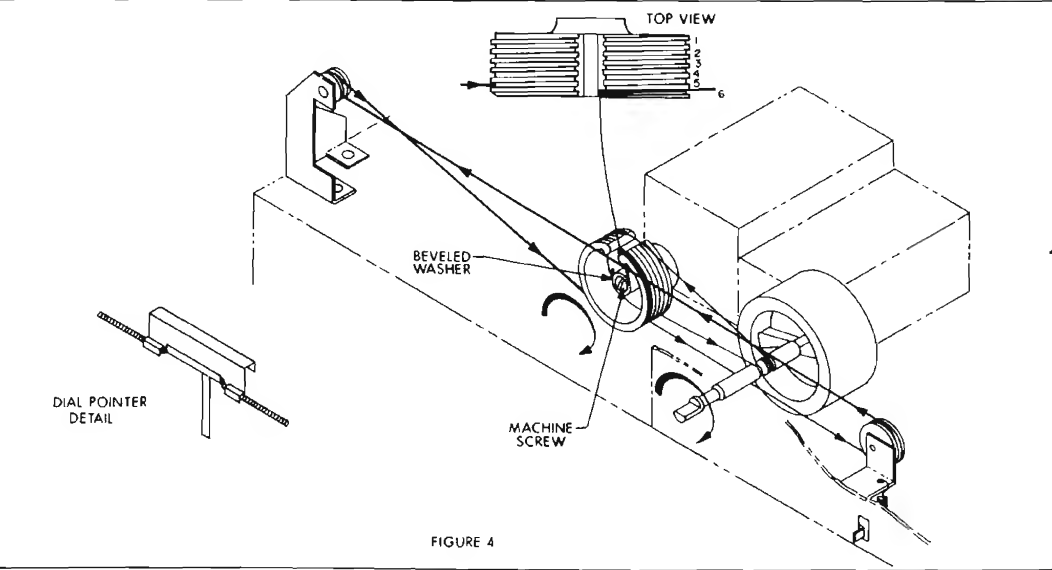
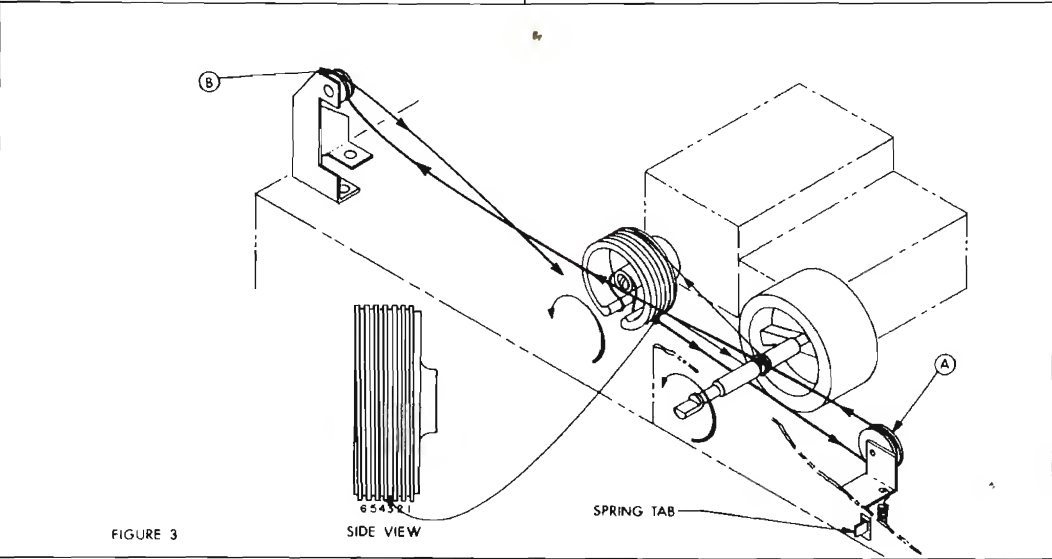
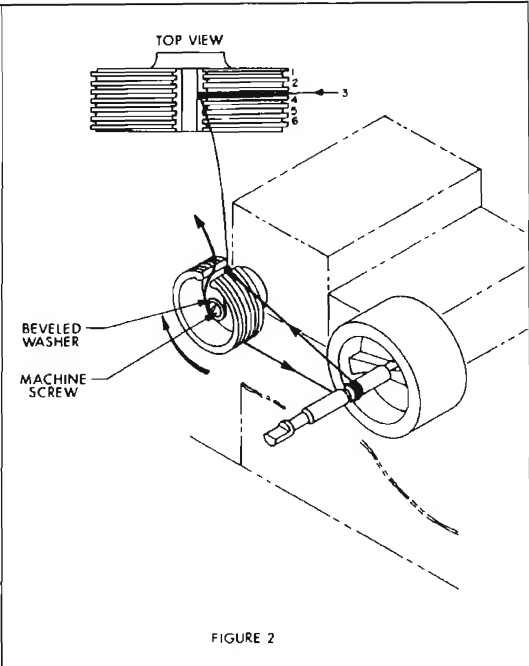

FIGURE 1



SERVICE PROCEDURES

MULTIPLEX ALIGNMENT

Two methods of aligning the multiplex decoder are given. The preferred procedure uses a multiplex generator with RF and 19 kHz (kc) outputs and with 1 kHz (kc) modulation, such as the FISHER 300 Multiplex Generator. This is the better method of alignment since the front end and IF stages are also checked through the use of this procedure. An alternate procedure for use with multiplex generators not having an RF output is also given.

PREFERRED ALIGNMENT PROCEDURE

Set SELECTOR switch to FM, MODE/TAPE MONITOR switch to STEREO and MUTING switch to OFF.

- (1) Connect RF output of multiplex generator to the FM ANT. antenna terminals. Set TUNING dial pointer to RF frequency of multiplex generator.
- (2) Connect output of audio generator, set for 1 kHz (kc), to the external modulation input of multiplex generator and to the external sync input of an oscilloscope. Connect the vertical input of the scope to pin 4B on the multiplex board and adjust the output of the multiplex generator for 1.4 volts peak-to-peak composite multiplex input (see Figure 1).
- (3) Ground pin 4C on the multiplex board to the chassis.
- (4) Follow procedures given in Table 1 below.
- (5) After alignment is complete, disconnect pin 4C from the chassis.

NOTE: Check the alignment of the IF amplifier before aligning the multiplex decoder. Poor IF alignment can make proper multiplex adjustment impossible.

ALTERNATE ALIGNMENT PROCEDURE

Set SELECTOR switch to FM, MODE/TAPE MONITOR switch to STEREO and MUTING switch to OFF.

- (1) Connect output of audio generator, set for 1 kHz (kc), to the external modulation input of multiplex generator and to the external sync input of an oscilloscope. Connect the vertical input of the scope to the composite output of the multiplex generator and adjust the output of the multiplex generator for 2 volts peak-to-peak composite multiplex output (see Figure 1).
- (2) Disconnect the lead going to pin 4B on the multiplex board. Connect the output of the multiplex generator through a 15K ohm to pin 4B on the multiplex board.
- (3) Ground pin 4C on the multiplex board to the chassis.
- (4) Follow procedures given in Table 1 below.
- (5) After alignment is complete, disconnect multiplex generator and resistor, and reconnect the lead going to pin 4B on the multiplex board. Disconnect pin 4C from the chassis.

INTERMODULATION DISTORTION TEST

Set BALANCE, BASS and TREBLE controls to their center positions. Set SELECTOR switch to AUX and

MODE/TAPE MONITOR switch to STEREO TAPE. Set LOUDNESS CONTOUR, LOW FILTER and HIGH FILTER switches to OFF. Unplug AC power cord.

- (1) Connect a 4-ohm, 50-watt resistor across the LEFT SPKRS MAIN terminals. In parallel with the load resistor, connect the input leads of an IM (Inter-Modulation) distortion analyzer and the input leads of an AC VTVM capable of reading 0.1 volts with accuracy.
- (2) Connect IM-analyzer generator output to the LEFT CHANNEL MON IN jack.
- (3) Connect AC power cord and rotate VOLUME control to its maximum clockwise position—full volume.
- (4) Increase IM-analyzer generator input to set for 25 watts output (8.2 VAC across 4-ohm load resistor). AFTER ONE FULL MINUTE OF WARM-UP TIME, PROCEED TO NEXT STEP.
- (5) IM meter reading should be 0.8% or less.
- (6) Repeat preceding steps for right channel.

NOTE: If any of the preceding instructions are different from those in the IM-analyzer instruction manual, it is best to follow those in the manual. If a load resistor of 50-watt rating is built into the IM analyzer, a separate load resistor is not required.

HARMONIC DISTORTION TEST

Set BALANCE, BASS and TREBLE controls to their center positions. Set SELECTOR switch to AUX and MODE/TAPE MONITOR switch to STEREO TAPE. Set LOUDNESS CONTOUR, LOW FILTER and HIGH FILTER switches to OFF. Unplug AC power cord.

- (1) Connect a 4-ohm, 50-watt resistor across the LEFT SPKRS MAIN terminals. In parallel with the load resistor, connect the input leads of a harmonic distortion analyzer and the input leads of an AC VTVM capable of reading 0.1 volts with accuracy.
- (2) Connect a low-distortion audio sine wave generator, set for 1000 Hz (cps), to the LEFT CHANNEL MON IN jack.
- (3) Connect AC power cord and rotate VOLUME control to its maximum clockwise position—full volume.
- (4) Increase audio generator input to set for 35 watts output (11.8 VAC across 4-ohm load resistor). Harmonic distortion meter should read 0.8% or less.
- (5) Repeat preceding steps for right channel.

POWER OUTPUT MEASUREMENT

The output amplifier of this unit is designed to deliver its full-rated power with program material (voice or music) into 4- to 16-ohm loads for an indefinite period of time. When a constant audio tone is used as a signal to measure the continuous RMS power output, the following precautions must be taken:

- (1) Measure the power output of one channel at a time.
- (2) Limit the measurement period to 10 minutes with a load resistance between 4 and 16 ohms.

WARNING: If the power output of both channels must ever be measured simultaneously, use a load of 4 to 8 ohms per channel and limit measurements to a period not longer than 3 minutes for a 4-ohm load and not longer than 5 minutes for an 8-ohm load.

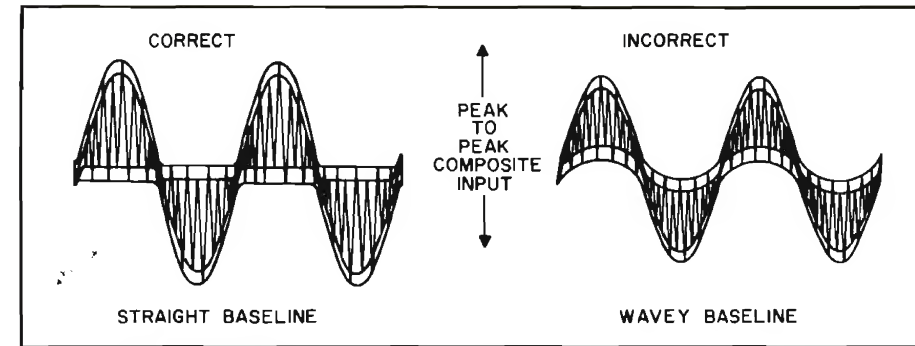

Figure 1. Composite Input To Multiplex Decoder.

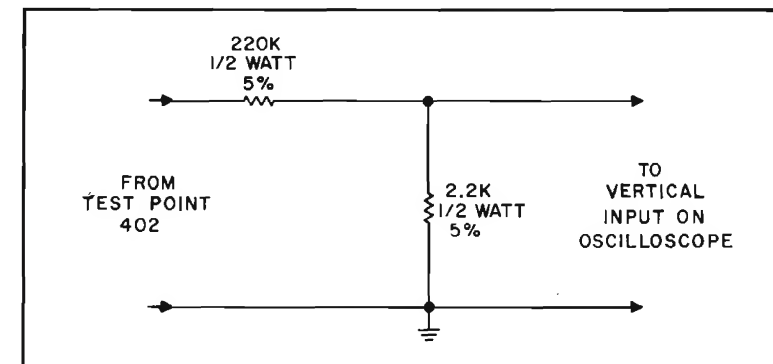

Figure 2. Voltage Divider Probe.

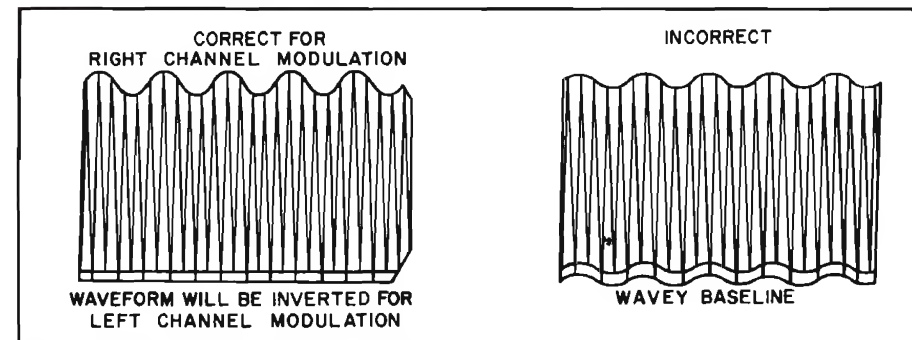

Figure 3. Waveform At Test Point 402.

TABLE 1. MULTIPLEX ALIGNMENT

STEP	Multiplex Generator Modulation	Indicator Type And Connection	Alignment	
			Adjust	Indication
1	Composite MPX signal modulated with 1 kHz (kc) on left channel only.	DC VTVM to Test Point 403.	Z401, Z402	Maximum reading on DC VTVM; approximately 3 VDC. Stereo Beacon should light.
2	Same as Step 1.	AC VTVM to left channel RCDR OUTPUT jack; scope thru voltage divider probe (see Figure 2) to Test Point 402.	Z403	Maximum waveform amplitude while maintaining straight baseline (see Figure 3) and maximum reading on AC VTVM. Record reading.
3	Same as Step 1.	AC VTVM to right channel RCDR OUTPUT jack.	Separation Control	Minimum reading on AC VTVM; at least 30 db below that recorded in Step 2. Record reading.
4	Composite MPX signal modulated with 1 kHz (kc) on right channel only.	Same as Step 3.	—	Same reading ± 2 DB on AC VTVM as recorded in Step 2.
5	Same as Step 4.	AC VTVM to left channel RCDR OUTPUT jack.	—	Same reading ± 2 db on AC VTVM as recorded in Step 3.*

* NOTE: If equal readings cannot be obtained in Steps 3 and 5, readjust Separation Control to make both readings approximately the same and 30 db below the readings in Steps 2 and 4.

SERVICE PROCEDURES

FM FRONT END ALIGNMENT

NOTE: FM IF alignment must be performed before starting this procedure. Set SELECTOR switch to FM, MODE/TAPE MONITOR switch to STEREO and MUTING switch to OFF.

(1) Set TUNING dial pointer to zero (0) calibration mark on the logging scale. If the dial pointer does not coincide with the 0 at the extreme end of the knob rotation, reposition the pointer assembly on the dial cord and cement the pointer in place to prevent slippage.

NOTE: Moving the dial pointer will make realignment of AM RF board necessary.

(2) Connect an FM generator to the FM ANT. antenna terminals. Use a 120-ohm composition resistor in series with each lead from the generator (see Figure 1).

(3) Connect a scope and an AC VTVM to either the LEFT or RIGHT CHANNEL RCDR HIGH jack.

(4) Set FM generator frequency and TUNING dial pointer to 90 MHz (Mc). Modulate generator with 400 Hz (cps) ± 75 kHz (kc) deviation. Use as low a generator output as possible.

NOTE: Use the tuning meter during alignment and adjust the generator output voltage to keep the meter reading between 2 and 4.

(5) Align FM oscillator coil (L504) core first—then align the FM RF coil (L502) and the FM mixer coil (L503) cores for maximum reading on AC VTVM and tuning meter and maximum waveform amplitude and symmetry.

(6) Set FM generator frequency and TUNING dial pointer to 106 MHz (Mc).

(7) Adjust FM oscillator trimmer (C507) first—then adjust the FM RF trimmer (C503) and the FM mixer trimmer (C506) for maximum reading on AC VTVM and tuning meter and maximum waveform amplitude and symmetry.

(8) Repeat alignment several times until accurate dial calibration and maximum gain are obtained. Keep the generator output as low as possible during all adjustments.

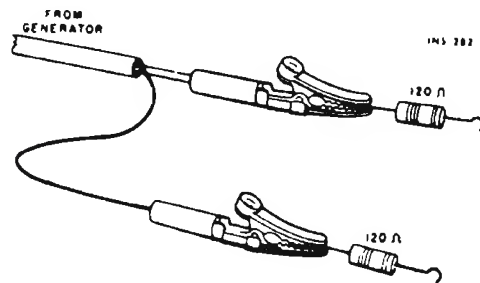

Figure 1. Connections To Provide 300-ohm Generator Output Impedance. Matching Resistors Reduce Generator Voltage By Half At The Antenna Terminals.

FM IF ALIGNMENT

Set SELECTOR switch to FM, MODE/TAPE MONITOR switch to STEREO and MUTING switch to OFF.

(1) Disconnect Test Point 501 on front end from ground.
(2) Connect 10.7-MHz (Mc) sweep generator to Test Point 501 on the front end. Connect scope's vertical input to Test Point 301 on the 10.7-MHz (Mc) IF amplifier board.

NOTE: Connect ground lead of generator to ground near Test Point 501 and ground of scope closest to the scope input.

(3) Adjust generator output voltage and frequency to observe IF response curve. Use as low a generator output as possible.

(4) Turn top core of Z302 on IF amplifier board fully out.

(5) Align top and bottom cores of Z303, bottom core of Z302, and top and bottom cores of Z301 on IF amplifier board, and core of L505 on front end for maximum gain and symmetry (see Figure 3). Repeat alignment until maximum gain and symmetry are obtained.

(6) Align top core of Z302 on IF amplifier board for maximum gain and symmetry (see Figure 2). Realign slightly top and bottom cores of Z302 for maximum gain and symmetry.

(7) Connect DC VTVM, set to 1.5-volt range, through a 100K to Test Point 302. Set generator to 10.7 MHz (Mc) with no sweep.

(8) Align top core of Z304 on IF amplifier board for reading on DC VTVM of 0 ± 0.2 VDC.

(9) Connect scope to LEFT or RIGHT CHANNEL RCDR HIGH jack. Set generator for sweep.

(10) Align bottom core of Z304 for maximum amplitude, linearity and symmetry (see Figure 4).

(11) Set generator to 10.7 MHz (Mc) with no sweep. Increase generator output to 200 mV.

(12) Adjust FM Meter Adjust Pot. R702 on meter and muting board for reading on tuning meter of 5.

(13) Align core of Z701 on meter and muting board for maximum indication on tuning meter; readjust generator voltage as necessary so meter reads between 2 and 4.

(14) After alignment, reconnect Test Point 501 on front end to ground.

FM TUNING METER CALIBRATION

Set SELECTOR switch to FM, MODE/TAPE MONITOR switch to STEREO and MUTING switch to OFF.

(1) Connect an FM generator to the FM ANT. antenna terminals. Use a 120-ohm composition resistor in series with each lead from the generator (see Figure 1).

(2) Connect scope to LEFT or RIGHT CHANNEL RCDR HIGH jack.

(3) Set FM generator frequency and TUNING dial pointer

to 90 MHz (Mc). Modulate generator with 400 Hz (cps) ± 75 kHz (kc) deviation; set generator output voltage to 12 μ V.

(4) Increase deviation to 250 kHz (kc); noise interference should be visible on waveform.

(5) Adjust generator frequency for equal amount of noise on both halves of the 400 Hz (cps) waveform on the scope.

(6) Decrease generator deviation to ± 22.5 kHz (kc).

(7) Align core of Z701 on meter and muting board for maximum reading on tuning meter.

(8) Increase generator output voltage to 1 mV. Adjust FM Meter Adjust Pot. R702 on meter and muting board for meter reading of 5.

(9) Set generator output voltage to 12 μ V and adjust IF Gain Pot. R308 on 10.7-MHz (Mc) IF amplifier board for meter reading of 3.

FM MUTING TEST

Set SELECTOR switch to FM, MODE/TAPE MONITOR switch to STEREO and MUTING switch to ON.

(1) Connect an FM generator to the FM ANT. antenna terminals. Use a 120-ohm composition resistor in series with each lead from the generator (see Figure 1).

(2) Connect scope to LEFT or RIGHT CHANNEL RCDR HIGH jack.

(3) Set FM generator frequency and TUNING dial pointer to 90 MHz (Mc). Modulate generator with 400 Hz (cps) ± 22.5 kHz (kc) deviation.

(4) Set generator output voltage to 1 mV, observe signal on scope.

(5) Decrease generator voltage until signal disappears from scope; tuning meter should read between 2.5 and 3.5.

(6) Increase generator output voltage until audio signal just reaches its maximum amplitude; tuning meter should read between 3 and 4.

(7) Set SELECTOR switch to FM LOCAL. Signal on scope should disappear.

(8) Increase generator output voltage until signal reappears on scope and just reaches its maximum amplitude. Generator output voltage should be between 700 and 1400 μ V.

AM RF ALIGNMENT

NOTE: AM IF alignment must be performed before starting this procedure.

Set SELECTOR switch to AM.

(1) Set TUNING dial pointer to zero (0) calibration mark on the logging scale. If the dial pointer does not coincide with the (0) at the extreme end of the knob rotation, reposition the pointer assembly on the dial cord and cement the pointer in place to prevent slippage.

NOTE: Moving the dial pointer will make realignment of FM front end necessary.

(2) Open the ground link at the AM ANT. antenna terminals. Connect an AM generator to the AM ANT. and GND terminals.

(3) Connect a scope and an AC VTVM to either the LEFT or RIGHT CHANNEL RCDR HIGH jack.

(4) Set AM generator frequency and TUNING dial pointer to 600 kHz (kc). Use 80% modulation with 400 Hz (cps) and readjust the generator output to keep reading on AC VTVM at 200 mV during the alignment procedure.

(5) Align AM oscillator coil (Z502) core first—then align the AM RF coil (Z501) and adjust the position of the small coil on the end of the ferrite loop antenna for maximum reading on AC VTVM and maximum waveform amplitude and symmetry.

NOTE: To adjust the antenna coil, melt the wax holding the small coil to the end of the ferrite loop antenna. Shift the coil back and forth for maximum audio indication. To secure the coil in position, remelt the wax.

(6) Set AM generator frequency and TUNING dial pointer to 1400 kHz (kc). Adjust AM oscillator trimmer (C516) first—then adjust the AM RF trimmer (C513) and the AM antenna trimmer (C501) for maximum reading on AC VTVM and maximum waveform amplitude and symmetry.

(7) Repeat alignment several times until accurate dial calibration and maximum gain are obtained. Keep the generator output as low as possible during all adjustments.

AM IF ALIGNMENT

Set SELECTOR switch to AM.

(1) Connect 455-kHz (kc) sweep generator to pin 5J on the AM RF board. Connect scope's vertical input through 1K ohm resistor to Test Point 603 on the 455-kHz (kc) IF amplifier board. Connect a 0.005- μ F capacitor between the scope input and pin 6H on IF board.

(2) Adjust generator output voltage and frequency to observe IF response curve. Use as low a generator output as possible.

(3) Align top and bottom cores of Z601 and Z602 on 455-kHz (kc) IF amplifier board and top and bottom cores of Z503 of AM RF board for maximum gain and symmetry (similar to Figure 3).

(4) Detune top core of Z602 2 turns counterclockwise.

(5) Realign top and bottom cores of Z503, bottom core of Z601 and top and bottom cores of Z602 for maximum gain at center frequency.

(6) Align top core of Z601 for maximum symmetry. Readjust slightly top and bottom cores of Z601 for maximum symmetry.

(7) Repeat alignment several times until accurate dial calibration and maximum gain are obtained. Keep the generator output as low as possible during all adjustments.

(8) After alignment, disconnect 0.005- μ F capacitor.

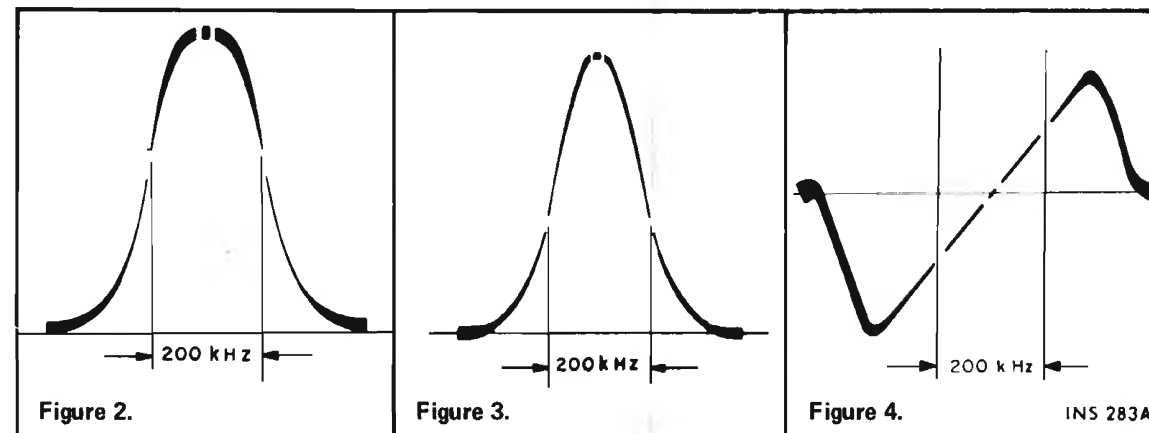

Figure 2.

Figure 3.

Figure 4.

INS 283A

SERVICE PROCEDURES

POWER AMPLIFIER CENTER VOLTAGE ADJUSTMENT

- (1) Connect two 10K $\pm 1\%$ resistors in series across capacitor C13 (3300 μ F). Connect the common lead of a DC VTVM to the junction of the two resistors.
- (2) Connect DC VTVM to the junction of resistors R827 and R829 (1 ohm) on the left channel portion of the dual channel power amplifier module. Adjust Center Voltage Adjust Pot. R813 on left channel predriver/driver board for reading of 0 ± 0.5 VDC on DC VTVM.
- (3) Connect DC VTVM to the junction of resistors R826 and R828 (1 ohm) on the right channel portion of the dual channel power amplifier module. Adjust Center Voltage Adjust Pot. R813 on right channel predriver/driver board for reading of 0 ± 0.5 VDC on DC VTVM.
- (4) Disconnect two 10K ohm resistors.

POWER AMPLIFIER IDLING CURRENT ADJUSTMENT

NOTE: Power amplifier center voltage adjustment must be performed before starting this procedure.

- (1) Connect DC VTVM across resistor R827 (1 ohm) on the left channel portion of the dual channel power amplifier module. Adjust Output Bias Adjust Pot. R818 on left channel predriver/driver board for reading of 40 ± 10 mV DC on DC VTVM.
- (2) Connect DC VTVM across resistor R826 (1 ohm) on the right channel portion of the dual channel power amplifier module. Adjust Output Bias Adjust Pot. R818 on right channel predriver/driver board for reading of 40 ± 10 mV DC on VTVM.

SERVICING INTEGRATED CIRCUITS

Integrated circuits are used in the tuner section of this unit to provide the theoretical maximum of AM suppression and limiting. The uA703E integrated circuit used in the 10.7-MHz FM IF amplifier and in the meter and muting circuit contains the equivalent of 5 transistors and 2 resistors. The TR80073 integrated circuit used in some models of the 10.7-MHz amplifier contains the equivalent of 10 transistors, 7 diodes and 11 resistors.

Both the uA703E and the TR80073 integrated circuits are high-reliability devices and should require a minimum of servicing. However, troubles may occur that will require servicing of these devices. In such an event, the integrated circuits should be serviced the same as a transistor. The preferred troubleshooting procedure is to first isolate the trouble to one stage using AC signal tracing methods. Once the suspected stage is located, the integrated circuit can be checked by measuring the DC voltages at the input and output pins of the integrated circuits using a DC VTVM. These DC voltages are the most accurate indications of the operating condition of the integrated circuit.

WARNING: Do not use an ohmmeter to check continuity with the integrated circuit on the printed circuit board; forward biasing the internal junctions within the integrated circuit may burn out the transistors.

When replacing an integrated circuit, the following precautions should be observed:

- (1) Do not replace a defective integrated circuit until the cause of the trouble is found. All external resistors, capacitors and transformers should be checked first to prevent the replacement integrated circuit from failing immediately due to a trouble in the connecting components.
- (2) Solder and unsolder each lead separately using a pliers or other heat sink on the lead to prevent damage from excessive heat.
- (3) Check that the leads of the replacement integrated circuit are connected to the correct locations on the printed circuit board before turning the set on.

1587-5 AM-FM FRONT END

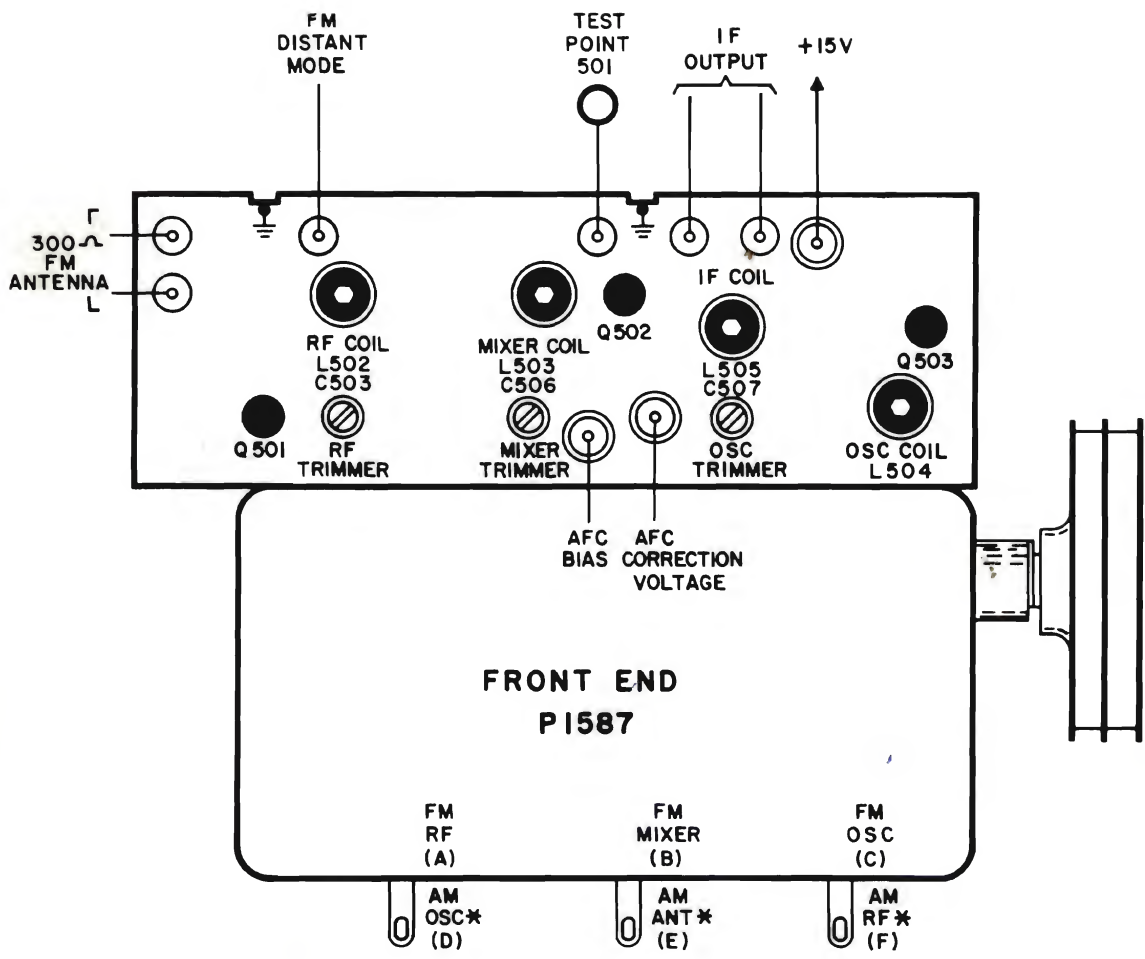
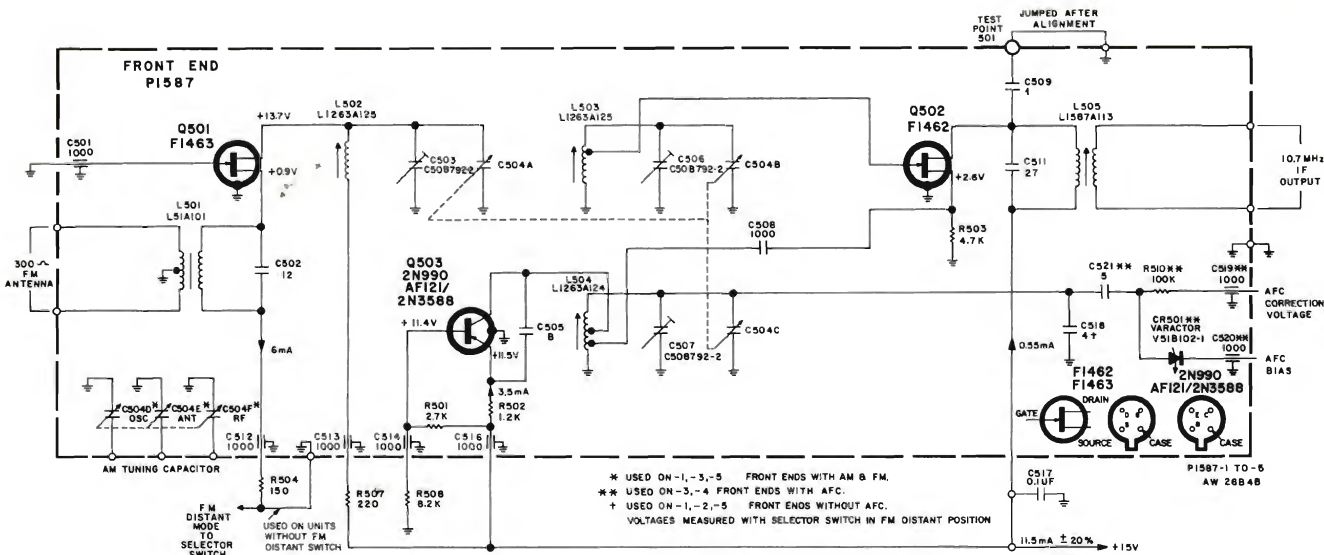

* USED ON -1, -3 FRONT ENDS

1575 10.7 MHz IF AMPLIFIER

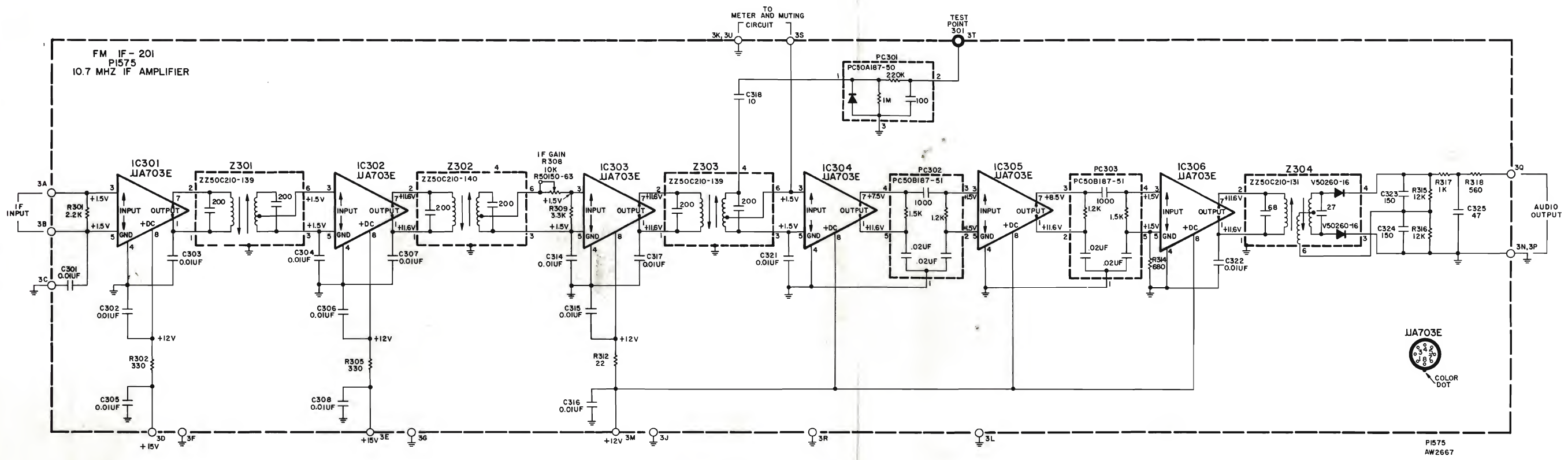

BOARD VIEWED FROM COMPONENT SIDE

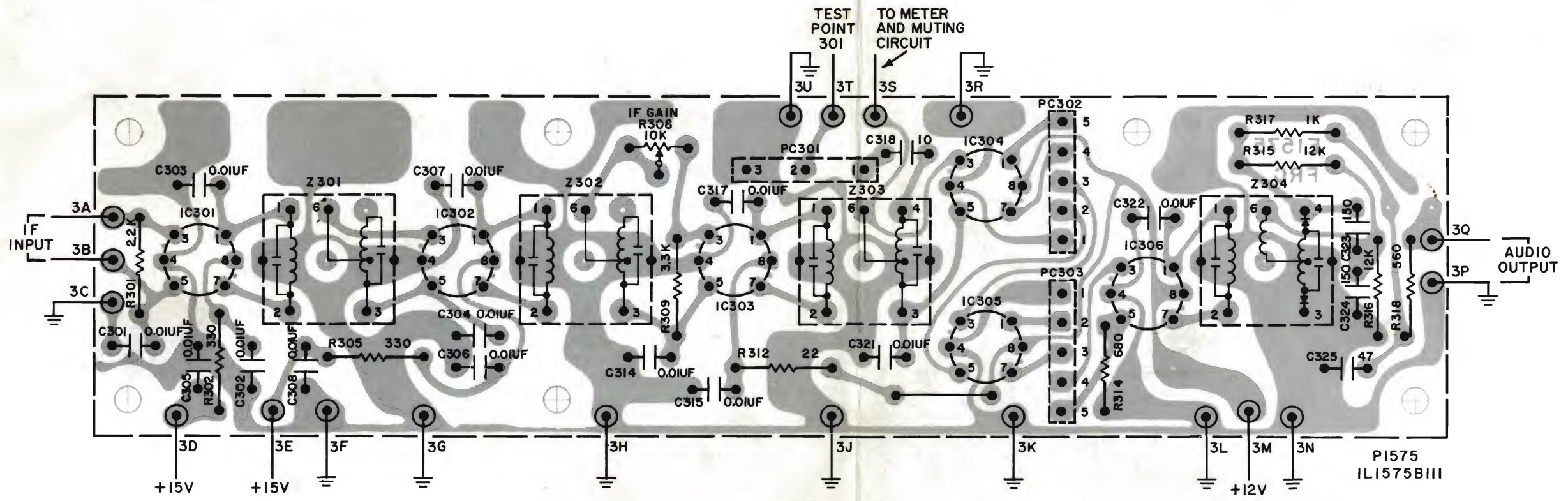

2006 AM RF

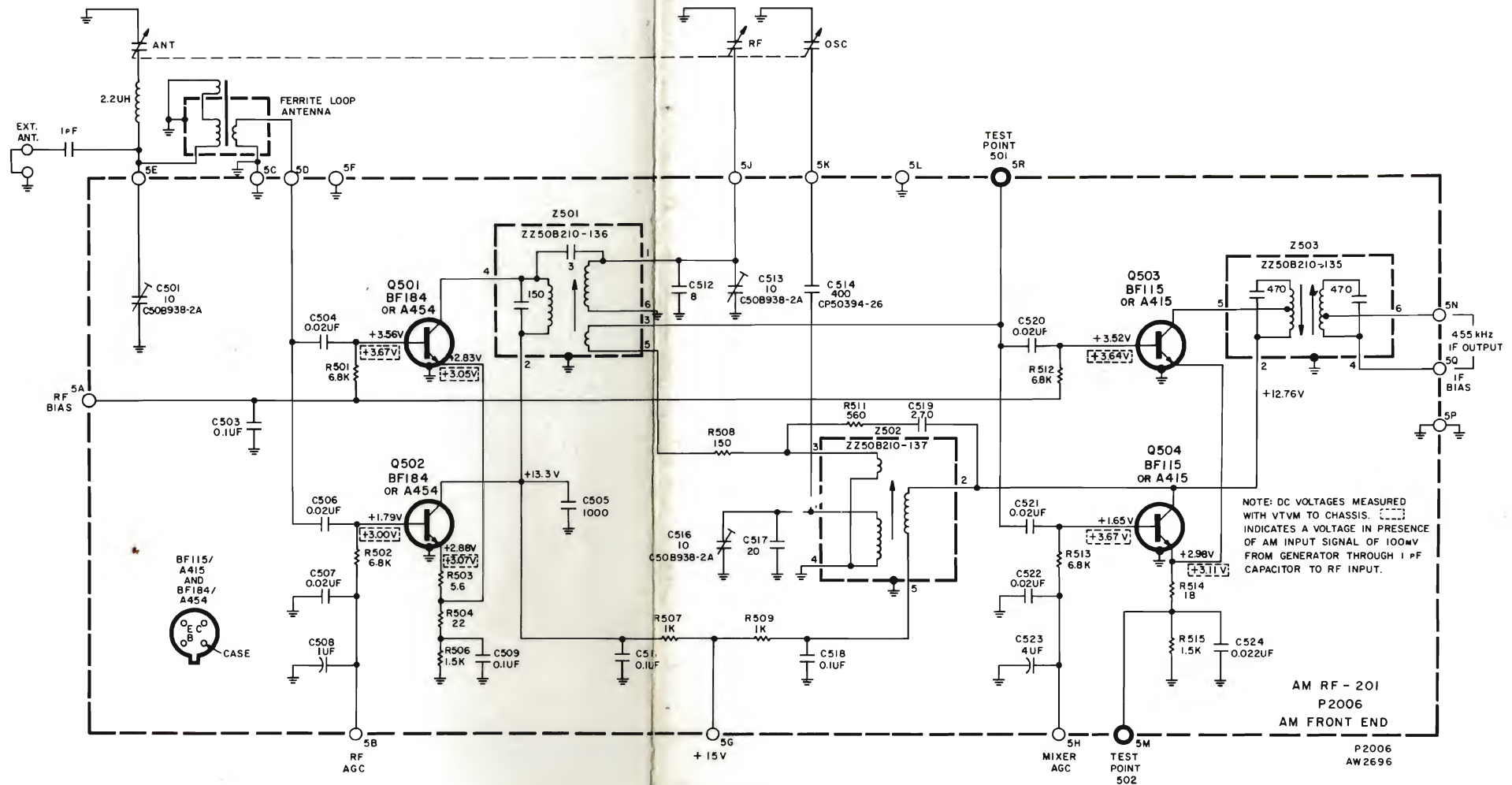

BOARD VIEWED FROM COMPONENT SIDE

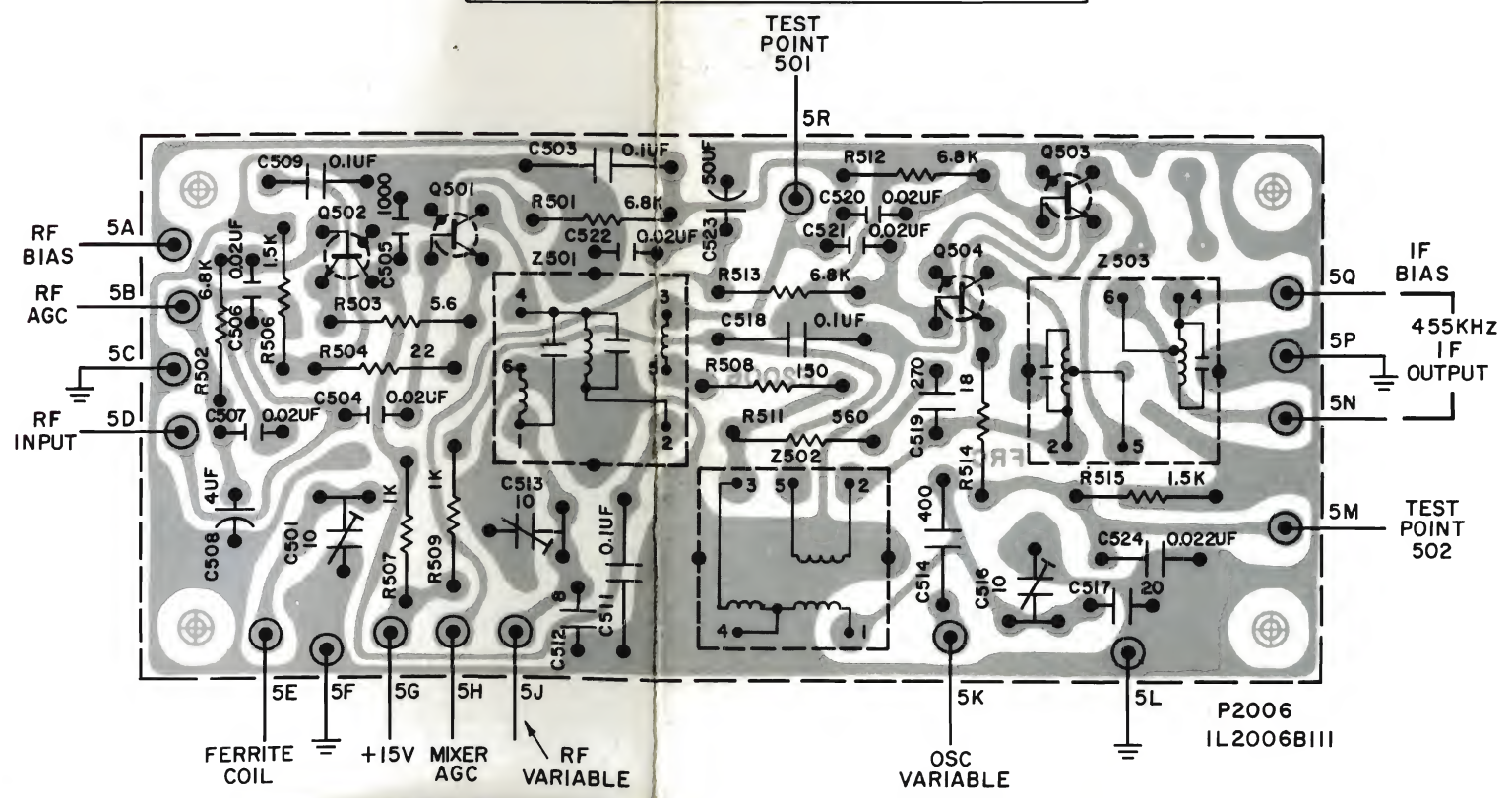

2005 455 kHz IF AMPLIFIER

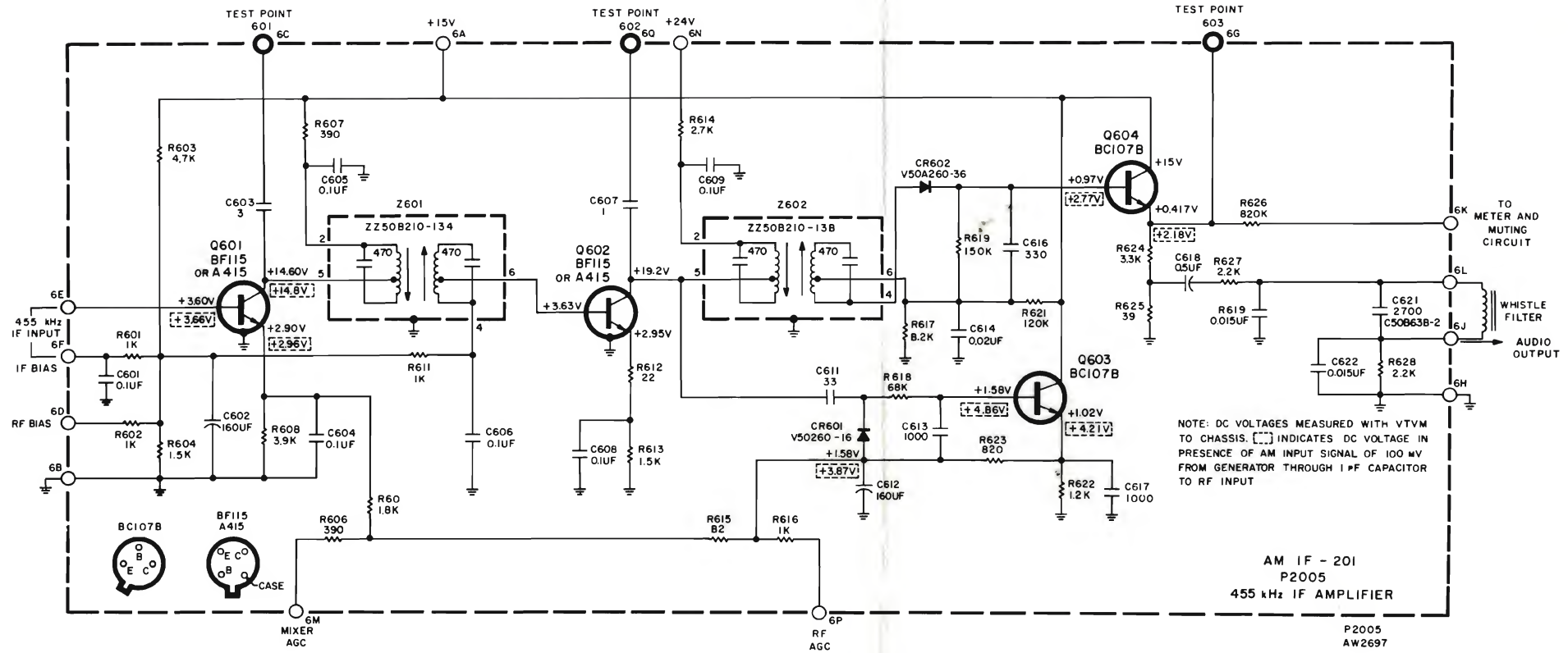

BOARD VIEWED FROM COMPONENT SIDE

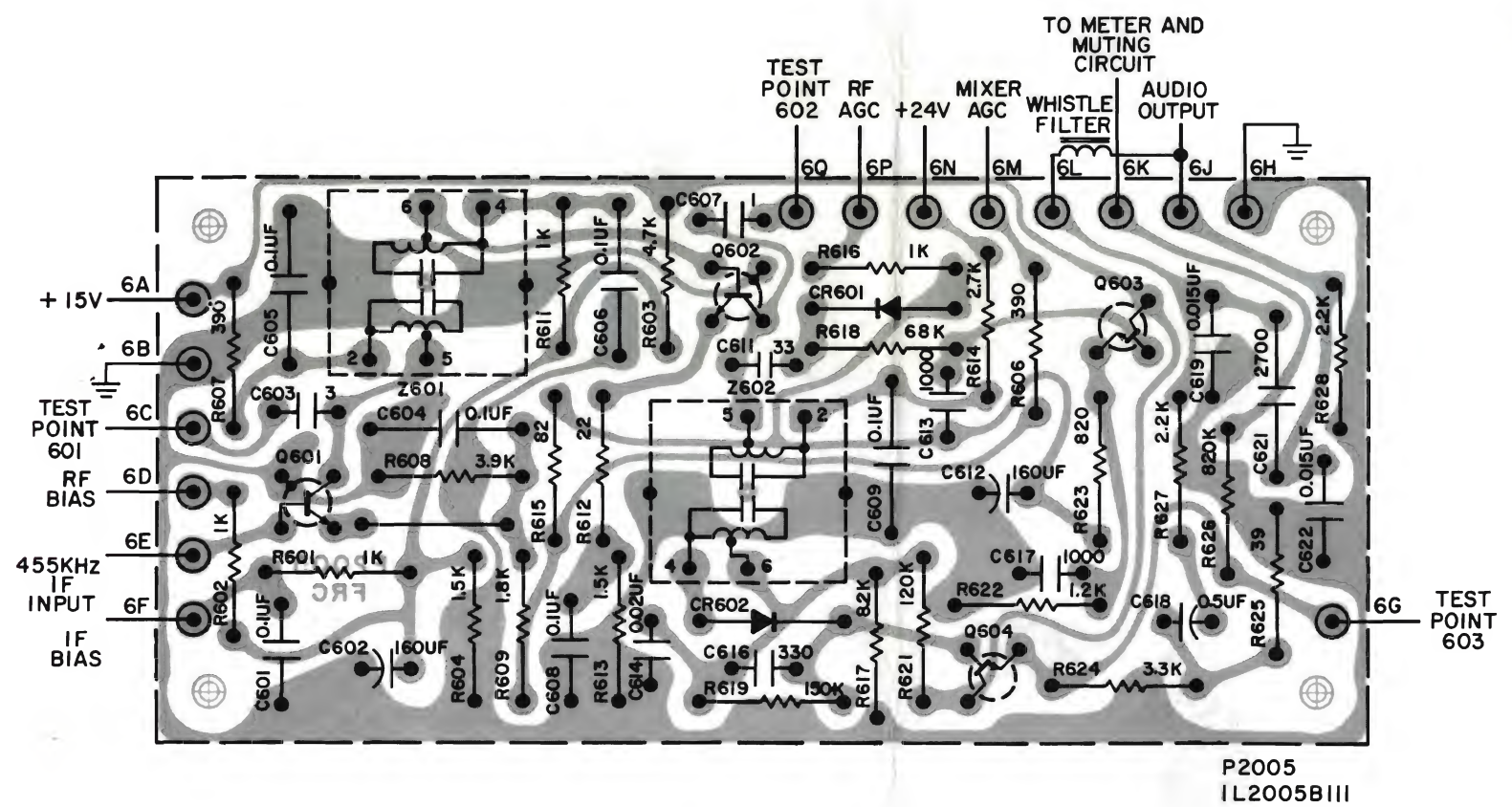

1541-1 MULTIPLEX DECODER

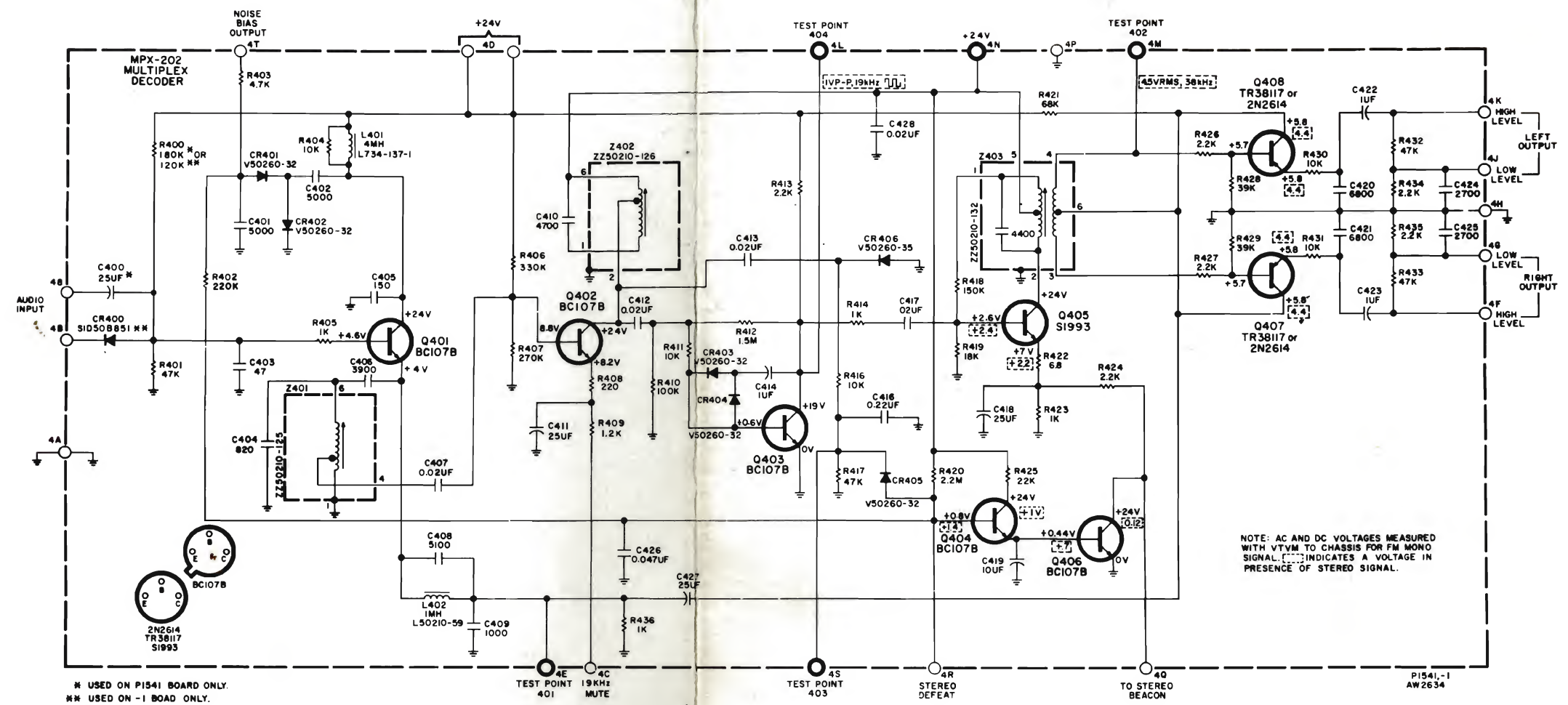

* USED ON P1541 BOARD ONLY.
 ** USED ON -1 BOARD ONLY.

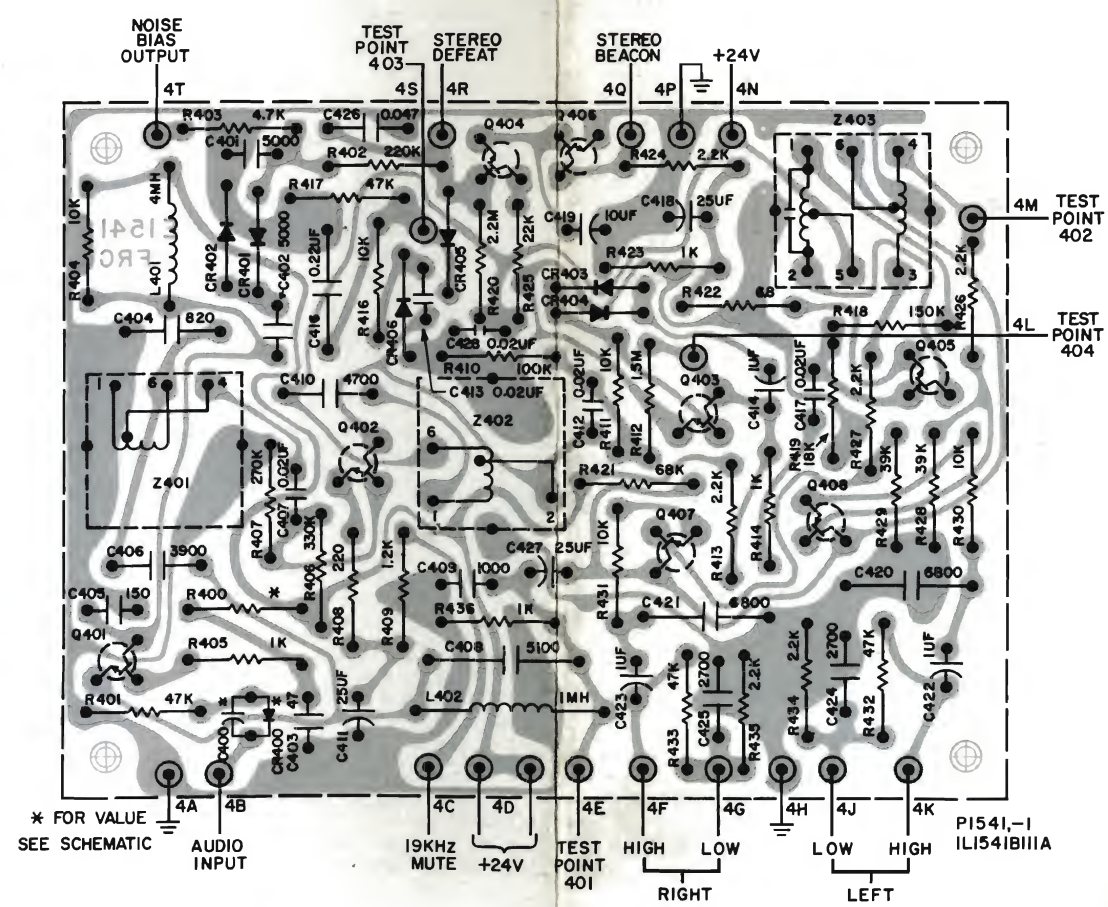

BOARD VIEWED FROM COMPONENT SIDE

P1541-1
 IL1541B11A

1278-4 AUDIO CONTROL AMPLIFIER

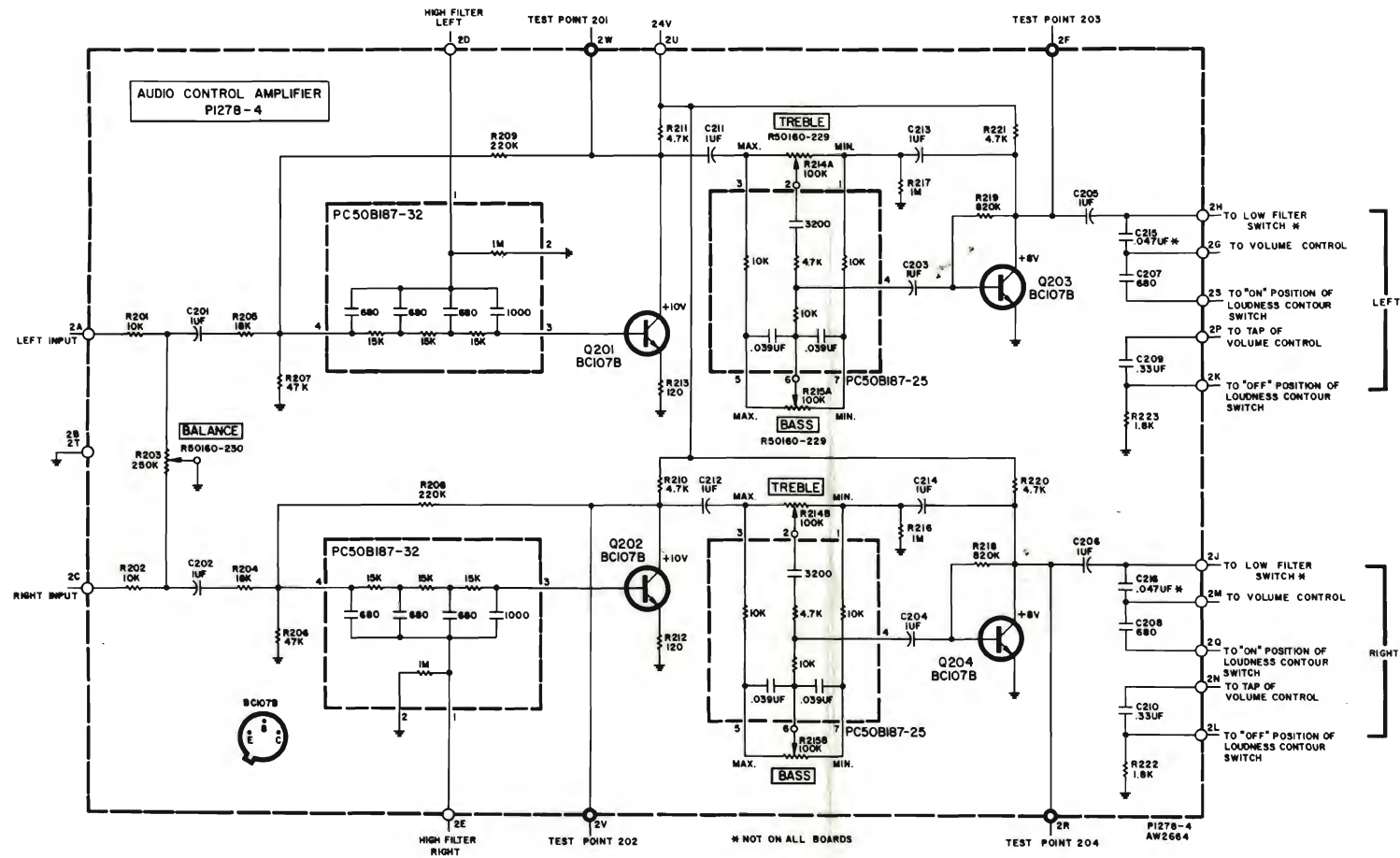

BOARD VIEWED FROM COMPONENT SIDE

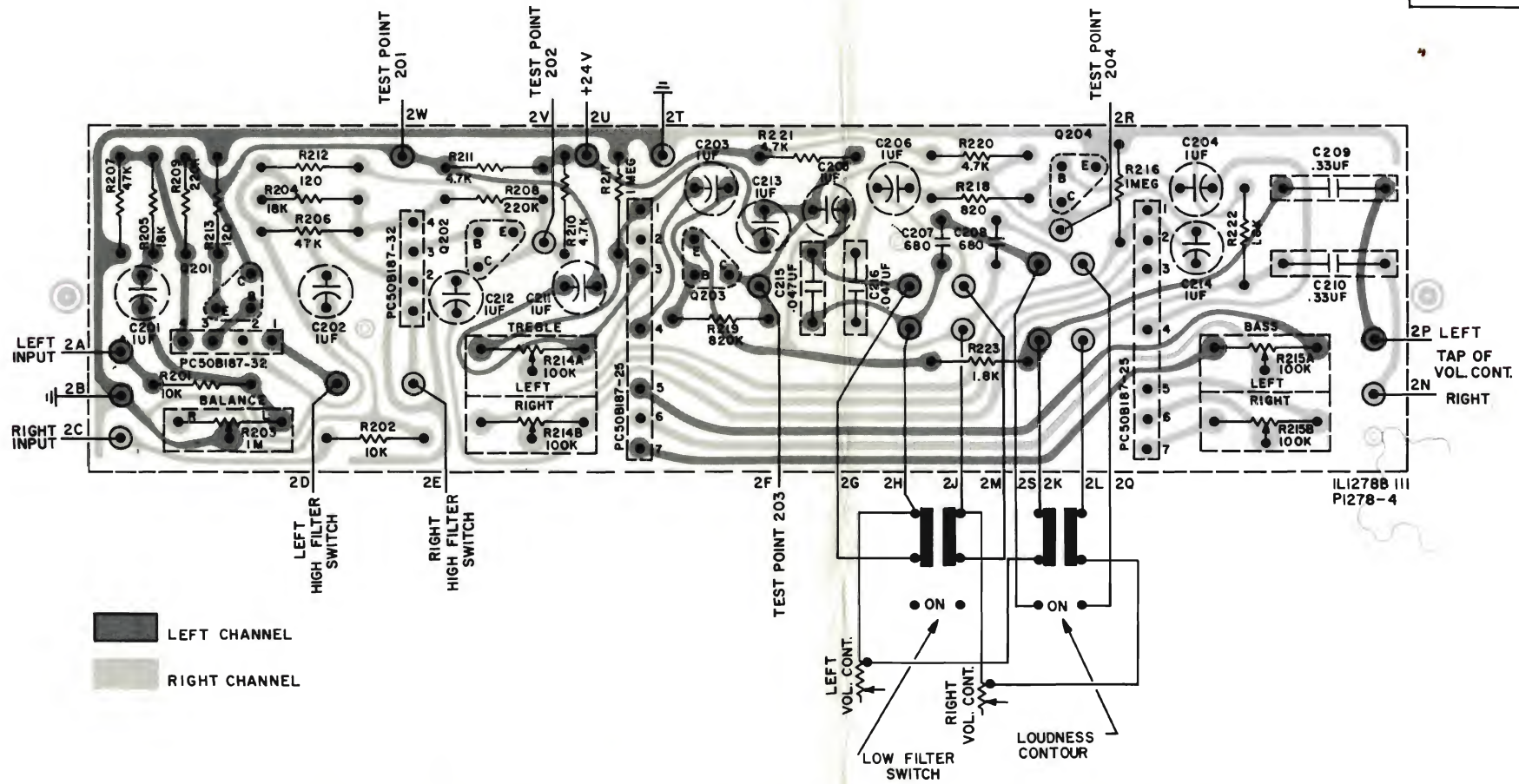

2145 DUAL CHANNEL POWER AMPLIFIER MODULE

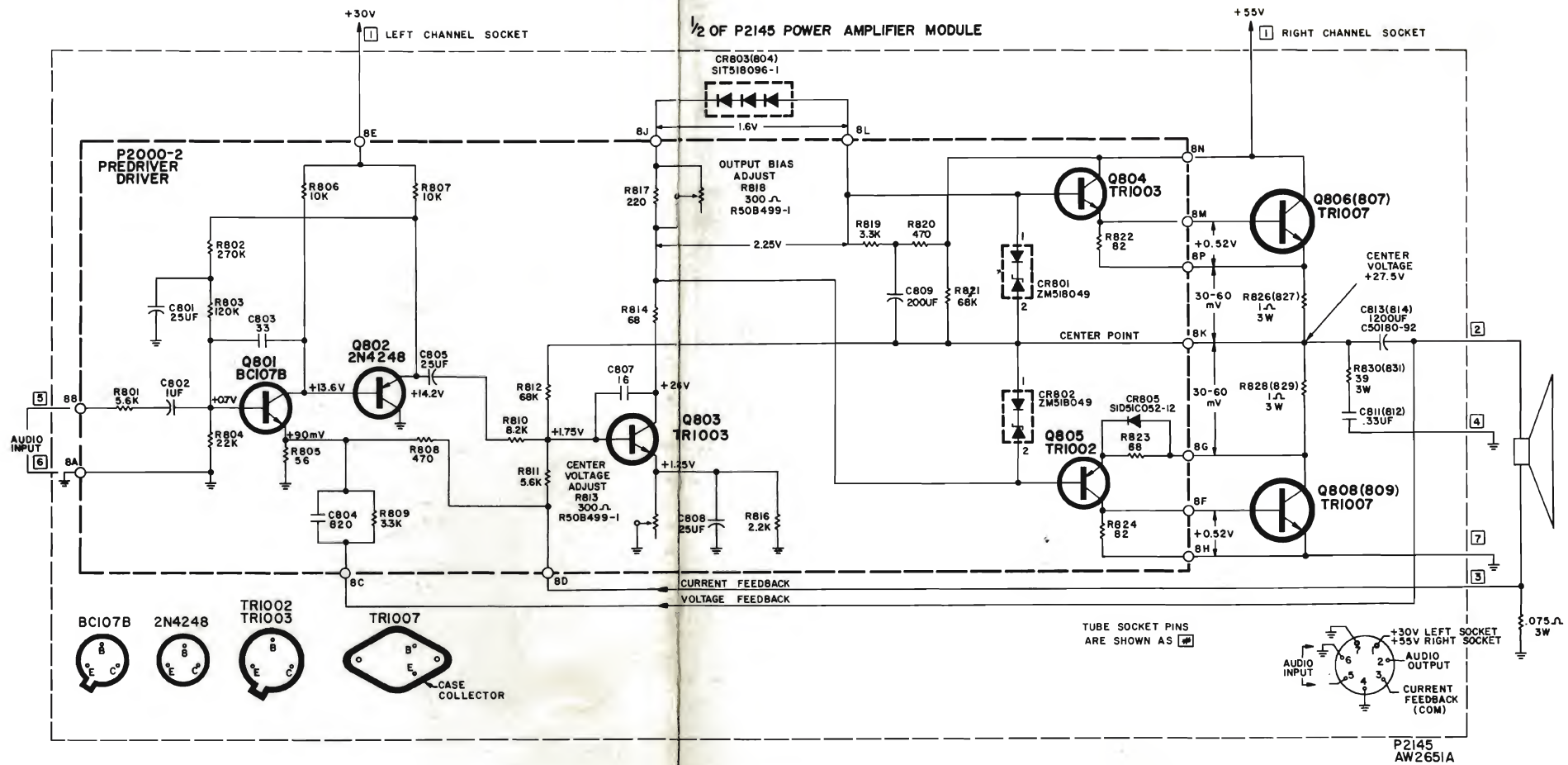

BOARD VIEWED FROM COMPONENT SIDE

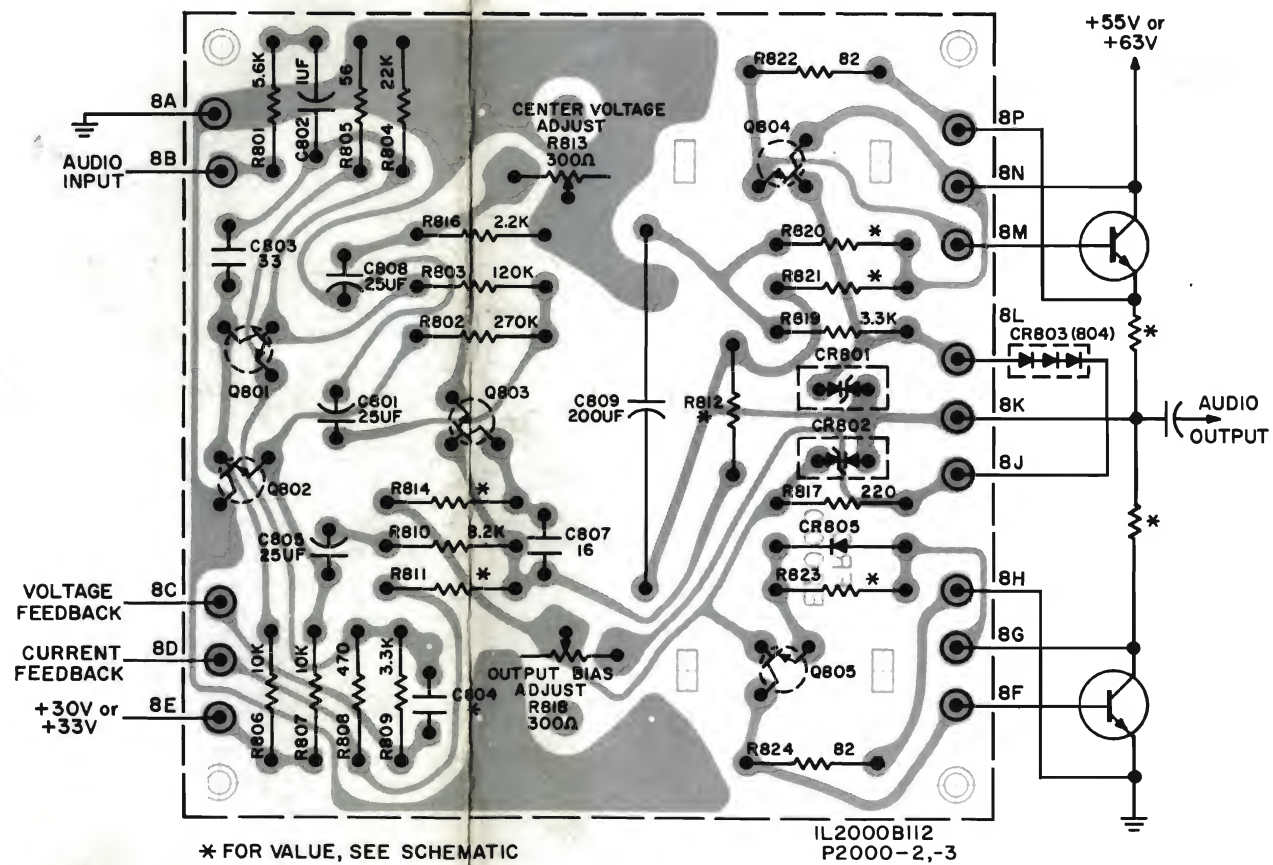

2003-2 PREAMPLIFIER

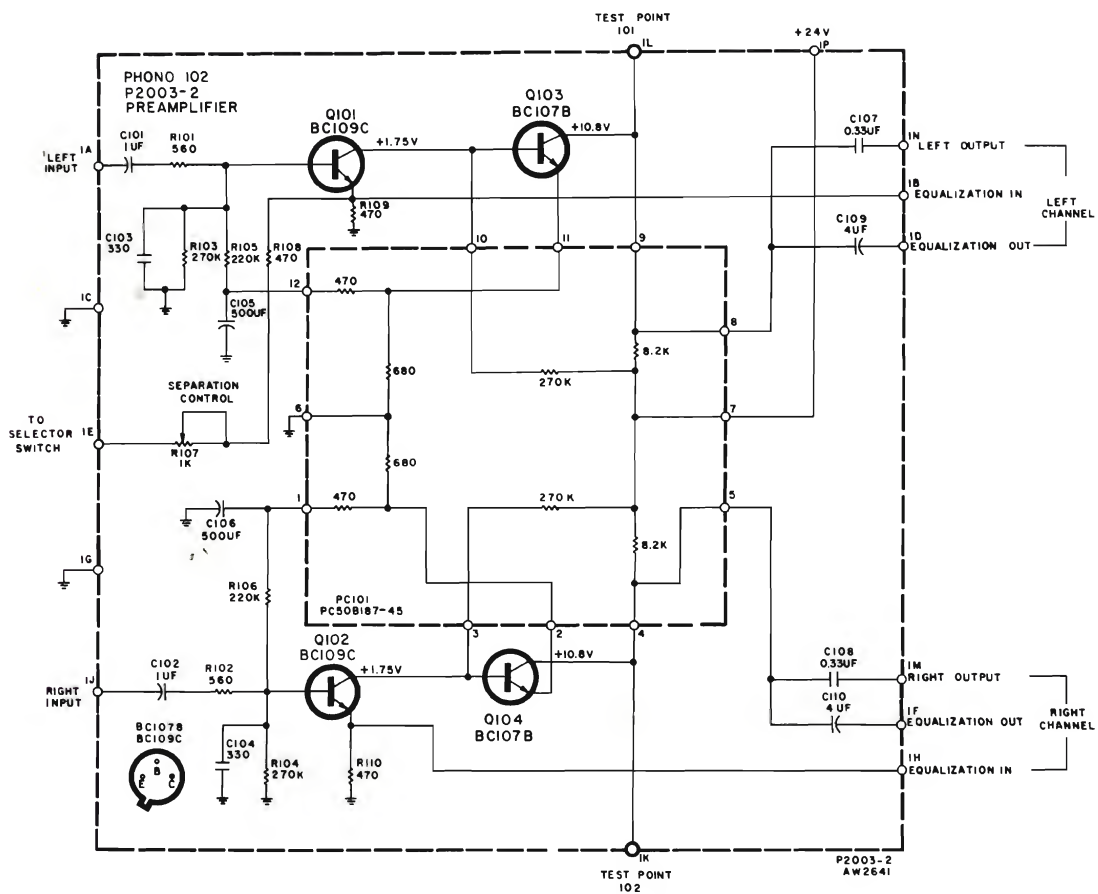

BOARD VIEWED FROM COMPONENT SIDE

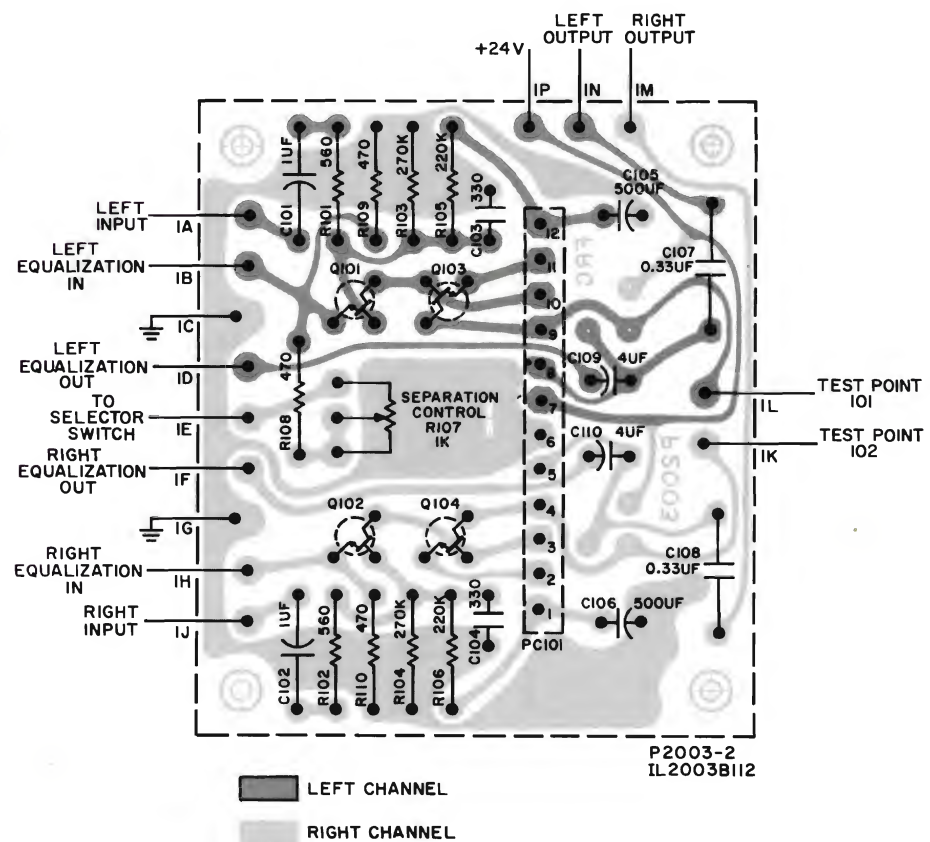

1577-3 METER AND MUTING

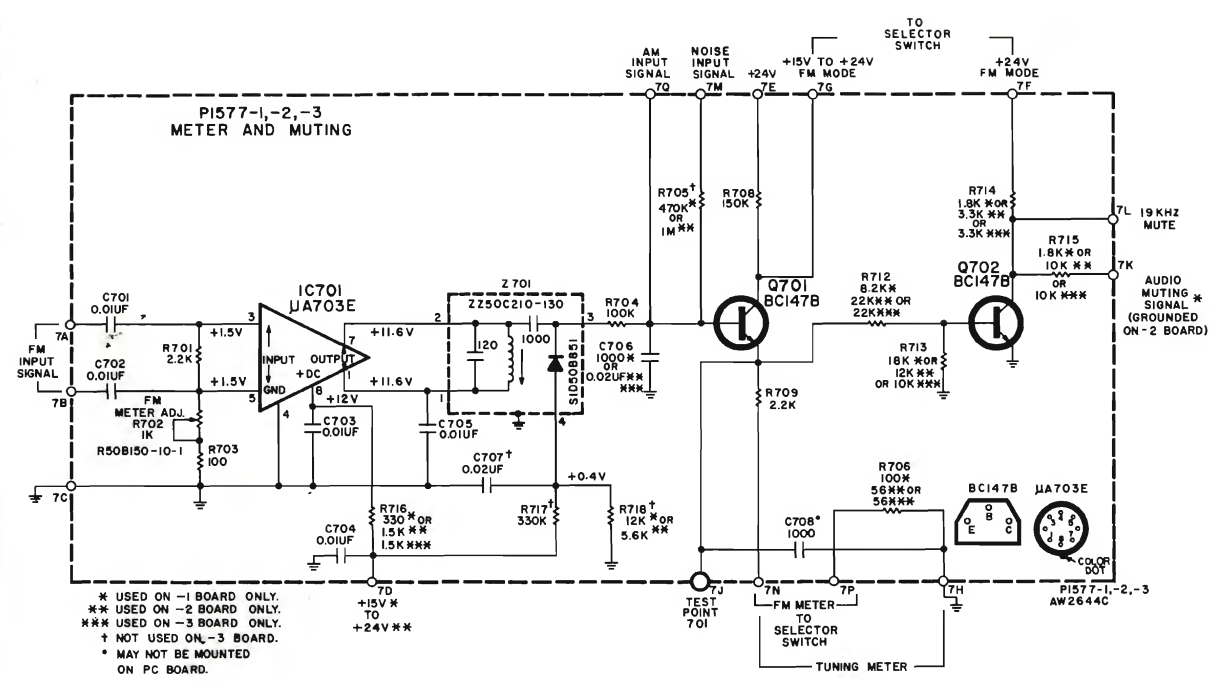

BOARD VIEWED FROM COMPONENT SIDE

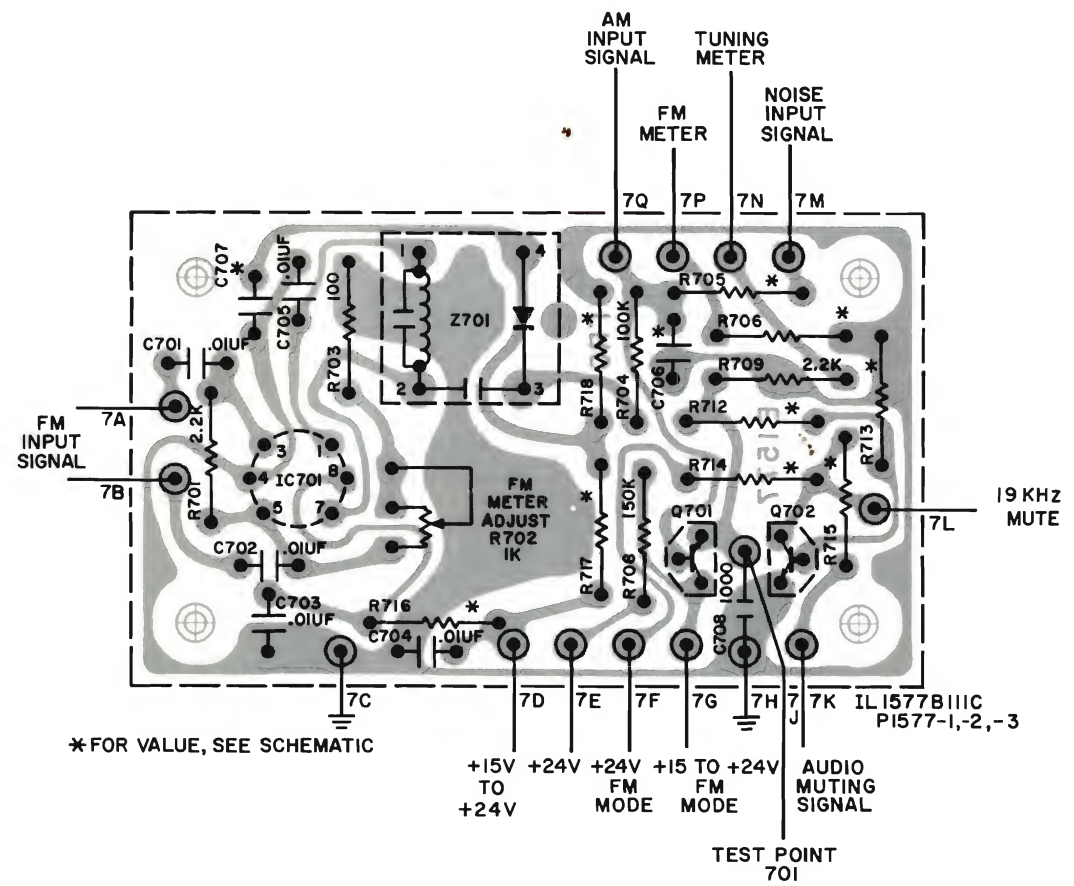

MAIN CHASSIS—TUNER SECTION

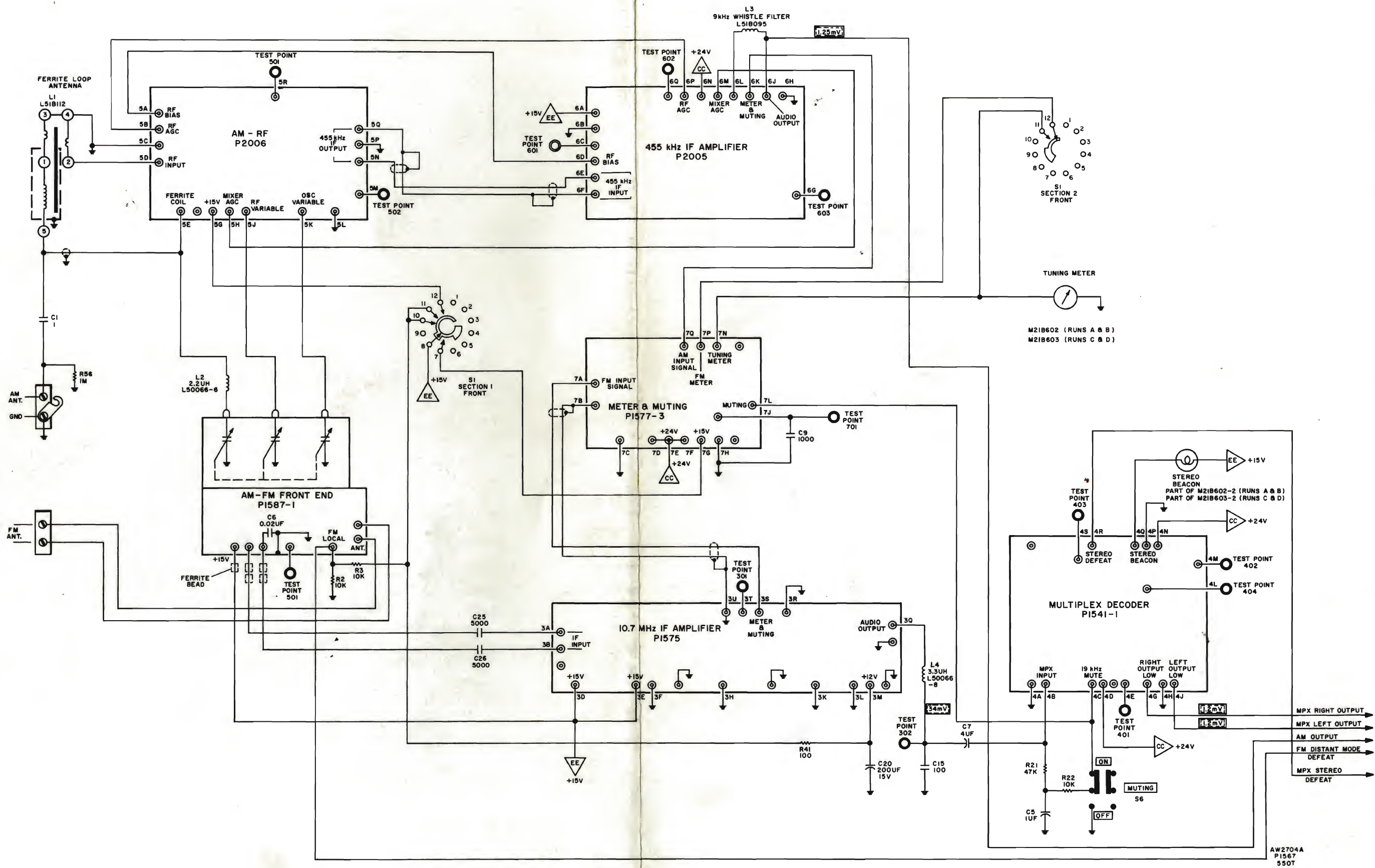

AW2704A
P1567
550T

MAIN CHASSIS-AMPLIFIER SECTION

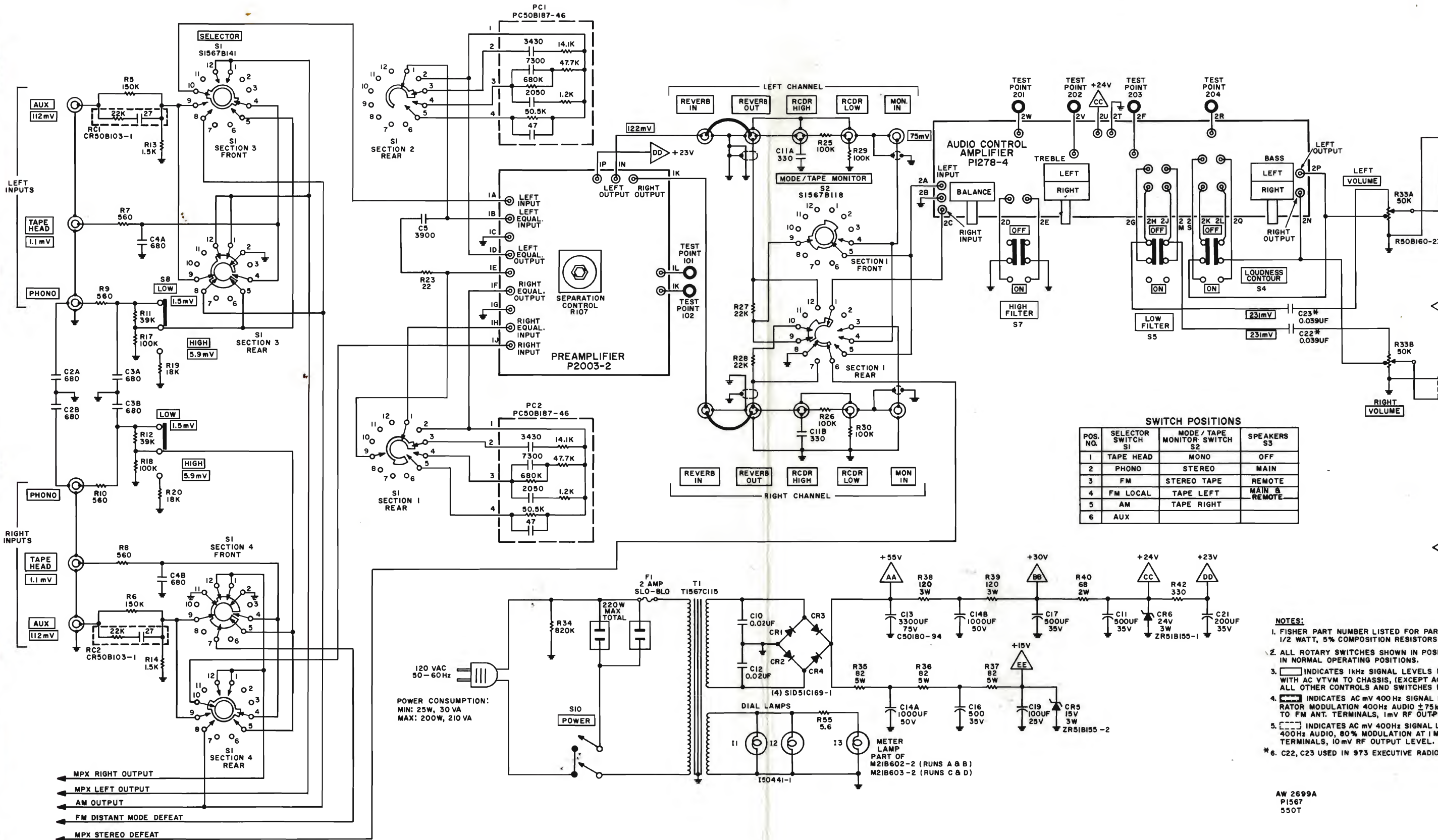

SWITCH POSITIONS

POS. NO.	SELECTOR SWITCH S1	MODE / TAPE MONITOR SWITCH S2	SPEAKERS S3
1	TAPE HEAD	MONO	OFF
2	PHONO	STEREO	MAIN
3	FM	STEREO TAPE	REMOTE
4	FM LOCAL	TAPE LEFT	MAIN & REMOTE
5	AM	TAPE RIGHT	
6	AUX		

- NOTES:**
- FISHER PART NUMBER LISTED FOR PARTS 1/2 WATT, 5% COMPOSITION RESISTORS.
 - ALL ROTARY SWITCHES SHOWN IN POSITION IN NORMAL OPERATING POSITIONS.
 - INDICATES 1kHz SIGNAL LEVELS FOR TAPE HEAD WITH AC VTVM TO CHASSIS, (EXCEPT ACROSS ALL OTHER CONTROLS AND SWITCHES).
 - INDICATES AC mV 400Hz SIGNAL LEVEL FOR TAPE HEAD MODULATION 400Hz AUDIO ±75kHz TO FM ANT. TERMINALS, 1mV RF OUTPUT.
 - INDICATES AC mV 400Hz SIGNAL LEVEL FOR TAPE HEAD MODULATION 400Hz AUDIO, 80% MODULATION AT 1MHz TERMINALS, 10mV RF OUTPUT LEVEL.
 - C22, C23 USED IN 973 EXECUTIVE RADIO-1.

MAIN CHASSIS-AMPLIFIER SECTION

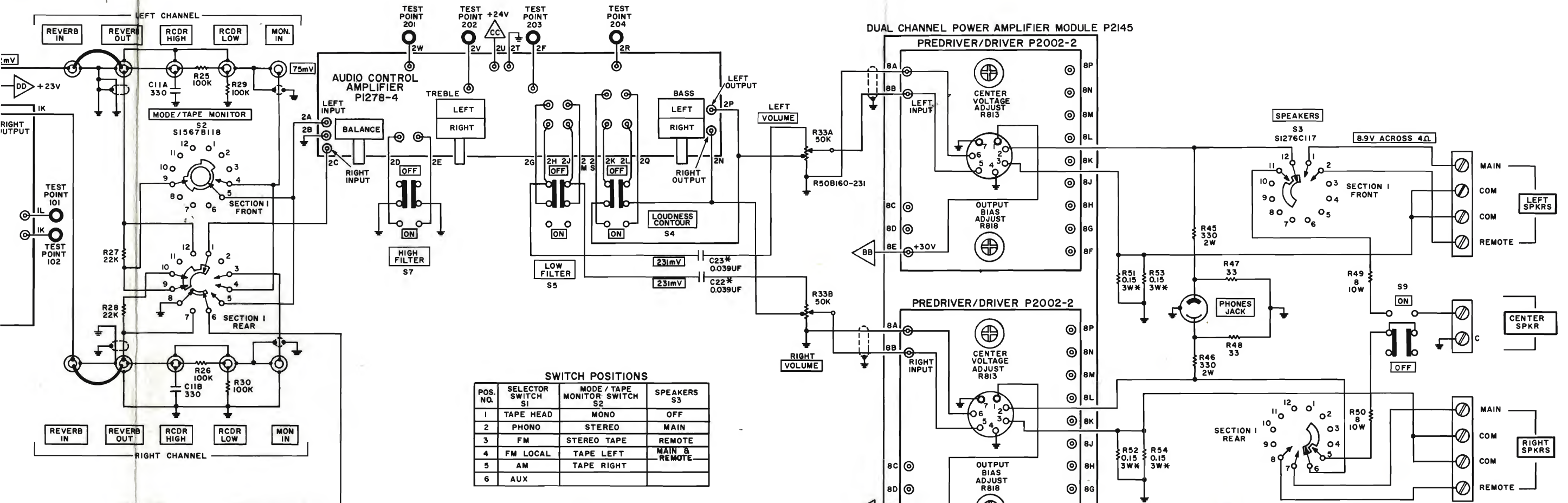

SWITCH POSITIONS

POS. NO.	SELECTOR SWITCH S1	MODE / TAPE MONITOR SWITCH S2	SPEAKERS S3
1	TAPE HEAD	MONO	OFF
2	PHONO	STEREO	MAIN
3	FM	STEREO TAPE	REMOTE
4	FM LOCAL	TAPE LEFT	MAIN & REMOTE
5	AM	TAPE RIGHT	
6	AUX		

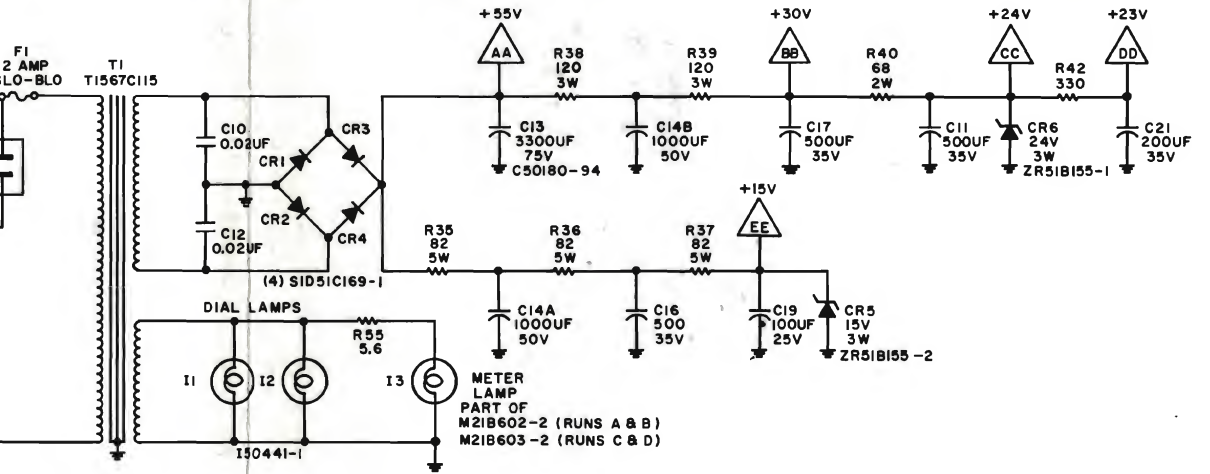

- NOTES:**
- FISHER PART NUMBER LISTED FOR PARTS SPECIALLY SELECTED FOR FISHER RADIO CORP; 1/2 WATT, 5% COMPOSITION RESISTORS MAY BE USED AS REPLACEMENTS EXCEPT AS NOTED.
 - ALL ROTARY SWITCHES SHOWN IN POSITION 1, ALL OTHER CONTROLS AND SWITCHES SHOWN IN NORMAL OPERATING POSITIONS.
 - [Symbol] INDICATES 1kHz SIGNAL LEVELS FROM AUDIO INPUTS TO AMPLIFIER OUTPUT, MEASURED WITH AC VTVM TO CHASSIS, (EXCEPT ACROSS 4Ω SPEAKER LOAD) VOLUME CONTROL MAXIMUM, ALL OTHER CONTROLS AND SWITCHES NORMAL FOR 20 WATTS OUTPUT.
 - [Symbol] INDICATES AC mV 400Hz SIGNAL LEVELS MEASURED IN FM MONO, MUTING ON. FM GENERATOR MODULATION 400Hz AUDIO ±75kHz DEVIATION AT 100MHz. GENERATOR OUTPUT CONNECTED TO FM ANT. TERMINALS, 1mV RF OUTPUT LEVEL.
 - [Symbol] INDICATES AC mV 400Hz SIGNAL LEVELS MEASURED IN AM. AM GENERATOR MODULATION 400Hz AUDIO, 80% MODULATION AT 1MHz. AM GENERATOR OUTPUT CONNECTED TO AM ANT. TERMINALS, 10mV RF OUTPUT LEVEL.
 - * C22, C23 USED IN 973 EXECUTIVE RADIO-PHONOGRAPH CHASSIS ONLY.

AW 2699A
P1567
550T

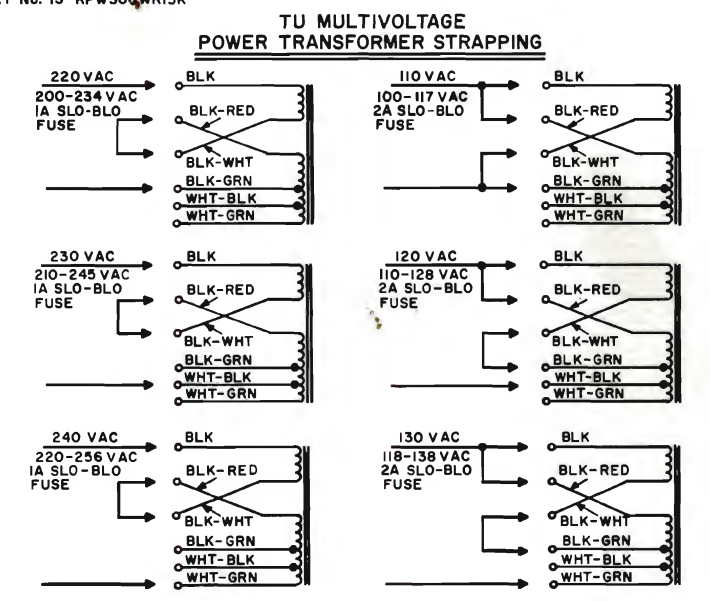

SERVICE NOTES

CHASSIS LAYOUT

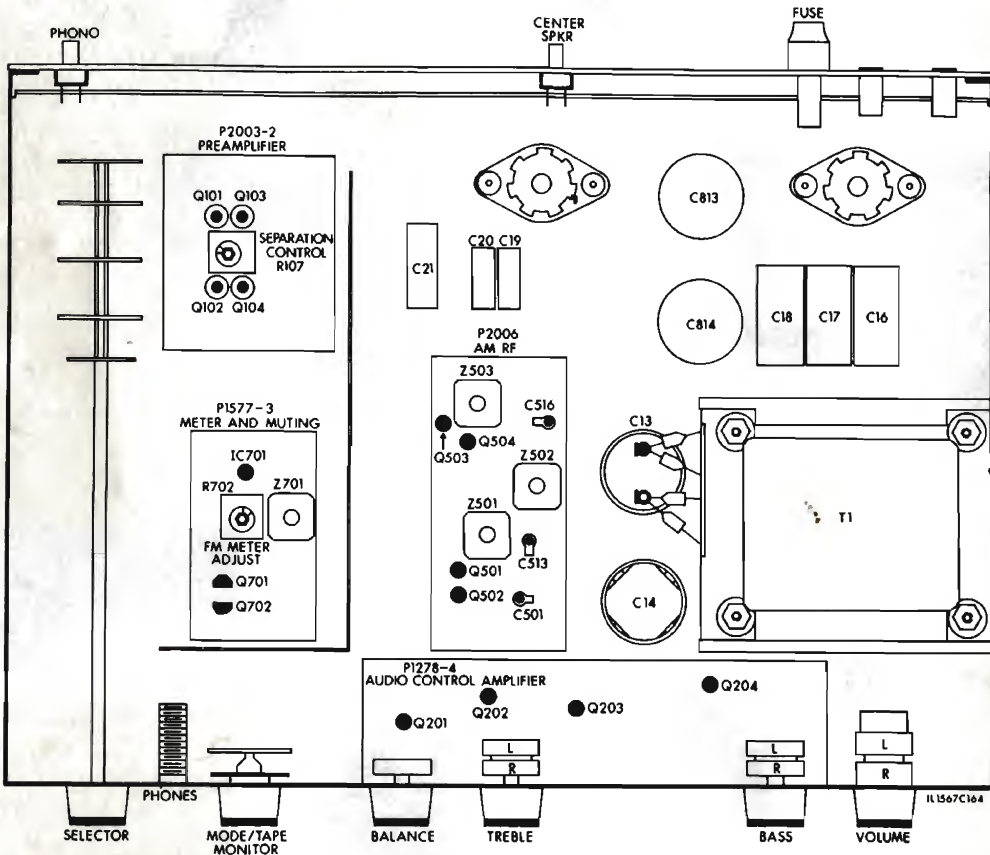
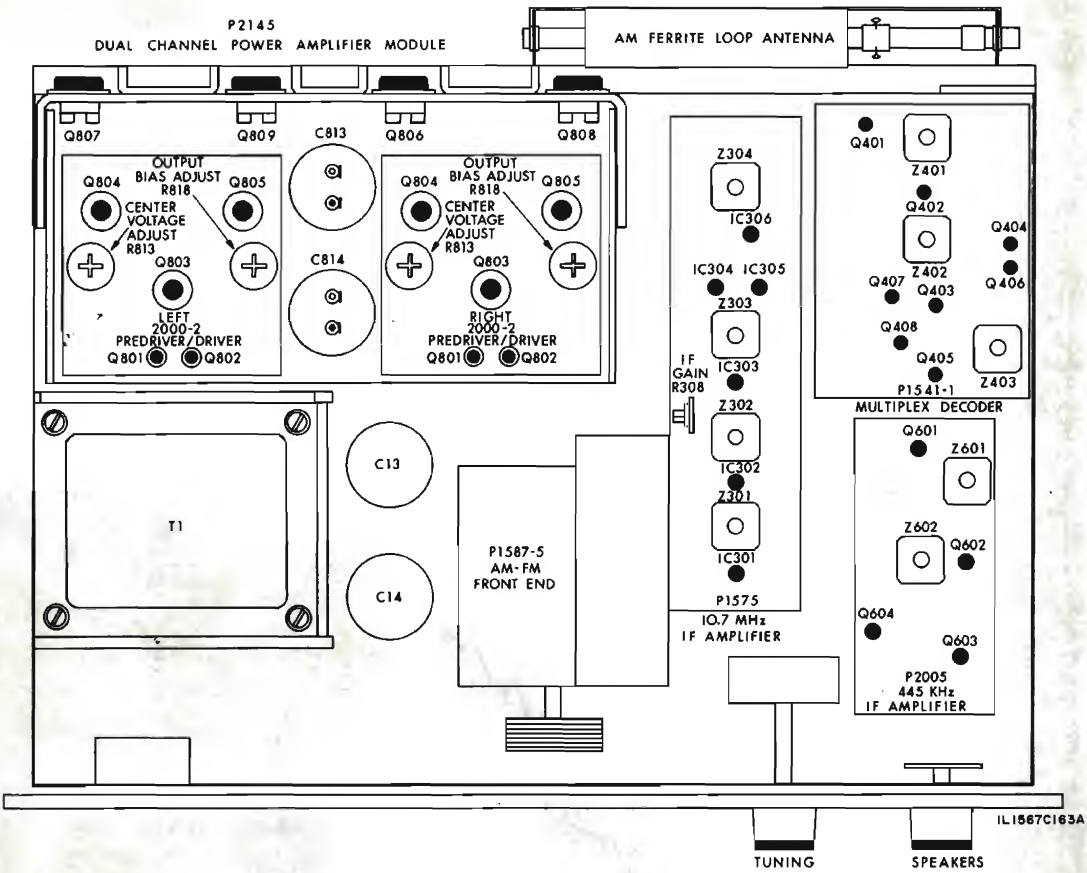

FISHER RADIO CORPORATION • NEW YORK