



Table of Contents

Introduction 3

Important Notes on Servicing 3

Ordering Replacement Parts 3

Block Diagrams 4

Start up Procedure 5

Protection Modes and Indicators 6

Troubleshooting Guide 7

Output Transistors Testing and Replacement 8

Calibrations and Adjustments 9

Parts List 10

Updates 11

Fuses 13

Voltage Change 13

Remote Interface Information 14

Schematics 15

The contents of this document as well as the files associated with it contain confidential information that is proprietary to Classé Audio Incorporated and are intended solely for the purpose of servicing product. No part of its contents may be used, copied, disclosed, or conveyed to any party in any manner whatsoever without prior written permission from Classé Audio Incorporated.

Introduction

**Please read this manual carefully before commencing servicing!
Only qualified and authorized personnel should attempt to service this product.**



The lightning flash with arrowhead symbol, within an equilateral triangle, is intended to alert the user to the presence of uninsulated dangerous voltage within the product's enclosure that may be of sufficient magnitude to constitute a risk of electric shock to persons.



The exclamation point within an equilateral triangle is intended to alert the user to the presence of important operating and maintenance (servicing) instructions.

Classé has a global product support network. For product assistance or to order replacement parts please contact your nearest service center always quoting the unit serial number.

North America

Phone: (978) 664-2870 E-mail: classe@bwgroupusa.com

Europe

Phone: 44 (0) 1903 221 700 E-mail: classe@bwgroup.com

Asia

Phone: (852) 2790 8903 E-mail: classe@bwgroup.hk

Rest of the World

Phone: (514) 636-6384 E-mail: cservice@classeaudio.com

Important Notes on Servicing

1. ALWAYS observe ESD precautions when handling electronic modules or PCBAs.
2. NEVER exchange boards with a different revision number, unless authorized by Classé.
3. ALWAYS use Classé original replacement parts. The use of generic parts may void the warranty of the unit.

Ordering Replacement Parts

There may be a delay in processing incomplete requests. Please be sure to include all required information. Remember to quote the serial number of the unit on all replacement part orders and the Classé order number when returning defective parts for credit.

Block diagrams

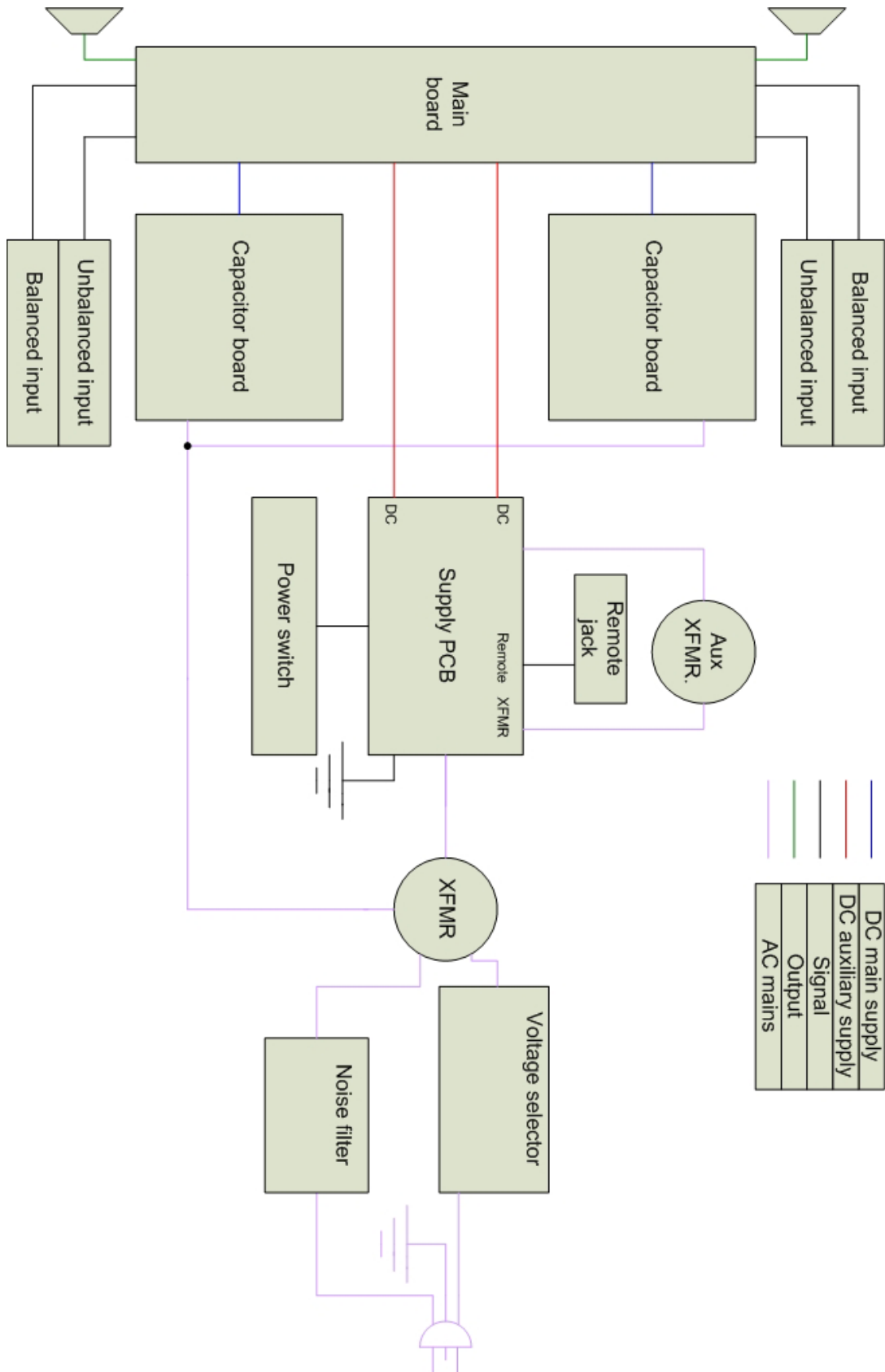

Start Up Procedure

When receiving a unit, an assiduous visual inspection must be performed. Do not connect the unit without analysing the symptoms reported by the customer and the results of the inspection.

Using the troubleshooting guide, find the problem and proceed to the repair. Once this step is done, follow these steps, known as the start-up procedure, to ensure that everything in the unit is in working condition.

1. Proceed with a post repair visual inspection. Take the time to check if every wire is reconnected properly, every screw is bolted on, no soldering and/or metal residues lying in the unit, every fuse has been replaced, etc.
2. Connect the unit to a variable transformer, setted to 0Vac.
3. Turn the bias trimpot (RV102) counter clockwise until a click is heard.
4. Connect the bypass wire to the variable transformer. This bypass is a power cord, modified on the female side in order to bypass the soft start sequence. It is connected to the line ring on voltage selector PCB.
5. Slowly raise the voltage to 10Vac, and check positive and negative rails and pre-driver supply. Check fuses.
6. If one or more supply are not within specifications, return to the troubleshooting guide.
7. Slowly raise voltage until you hear relays click, this point is around 55Vac. Recheck every supply.
8. If one or more supply are not within specifications, return to the troubleshooting guide.
9. Raise voltage to 120Vac. Recheck every supply
10. If every supply is within specifications, unplug the unit and bypass from the variable transformer. Reconnect only the unit.
11. Report to Calibration and adjustments (section 9) to adjust bias and DC offset. Note that bias can be adjusted to 14mV, and the following tests can be performed before the unit is send to the burn-in bench for a 24 hours warm-up.
12. Connect the unit to a load, and to a source using balanced inputs and single ended inputs, independently.
13. Perform a test with a 200Hz, a 2kHz and a 20kHz tone, both sinus wave and square wave. Check the output with a oscilloscope, on 4 ohms and 8 ohms loads. Take special cares about oscillation and phase correlation between channels.
14. Connect the unit to a small speaker, and short the input. Check for any noise. Perform this step with single ended inputs and balanced inputs, independently.
15. Put the unit on a burn-in bench, and let it sit for 24 hours, then readjust bias. Let the unit on the burn-in bench for another 72 hours.
16. Redo steps 11 to 14 before shipping to the customer.

Protection Modes and Indicators

The front LED shows the status of the amplifier. When starting up normally, the CA150 and CA151 will show a FLASHING RED LED for about 15 seconds and if all is normal, the LED will go SOLID RED. If there is a fault, the LED will go to a FLASHING GREEN LED. The CA150 and CA151 are equipped, except for some early production models, with four rails protection fuses. In the event that one or more of these fuses would blow, the technician will first need to identify and cure the cause of failure (please report to troubleshooting guide). When the cause has been identified, disconnect the unit from the system including the AC power. Remove the top cover and look for damaged or burned components. If no other components than the fuses appear to be damaged, the technician can then replace the broken fuses with the same value and rating (please report to fuses section). The rail fuses are located on the capacitor board. When replacing fuses, please make sure that the fuse holder are holding the fuses very tightly. A loose fuse holder can translate into distortion on top of the signal.

Troubleshooting Guide

Symptom	Possible cause
Unit won't turn on	Check connections; Check fuses; Check soft-start circuit; Check relays; Check power supply circuits (positive rail, negative rail, Mosfet supply).
Smoked and/or burned components	Check for short between components and ground; Check output transistors; Check output relays; Check power supply circuits (positive rail, negative rail, Mosfet supply).
Blown fuses	Check for short between fuse and ground; Check power supply circuits (positive rail, negative rail, Mosfet supply).
No output	Check connexions; Check output relays; Check power supply circuits (positive rail, negative rail, Mosfet supply); Check output transistors.
Unit turn into protection	Check for smoked and/or burned components; Check power supply circuits (positive rail, negative rail, Mosfet supply); Check source and load; Check protection circuit; Check sensor wires between sensor PCB and control PCB; Check outputs transistors and Mosfet drivers.
Excessive buzz and/or hum	Check electrical lines; Check for a ground loop in the system.
Oscillation	Check source; Check capacitors on main board; Check 4.7Ω resistor.
Intermittent signal	Check connections; Replace shield wires.

Output Transistors Testing and Replacement



PLEASE NOTE THAT THESE TESTS ARE ONLY EFFECTIVE ON BIPOLAR TRANSISTORS. DO NOT PERFORM THESE TESTS ON MOSFET DEVICES, AS THEY ARE LIKELY TO BECOME SHORT DURING THE TEST.

You should check all pin combinations, as there is a chance that only one side of the transistor is short. When replacing output transistors, the technician should first disconnect both outputs and main board to check if the blown outputs were caused by a faulty component on the amplifier's base. Blown output transistors should be replaced by kits, not individually. These kits contain matched transistors for both rails of one channel. When replacing blown output transistors, you must also replace positive and negative Mosfet drivers and bias transistor. Carefully inspect 4.7Ω resistor and 10Ω soft start resistor, and replace if necessary. Replace any burnt component or board.

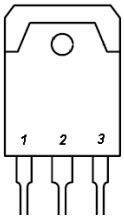

Pins : 1 Base
 2 Collector
 3 Emitter

You should have these results, if the transistor is good.

2SC3263 (NPN)

Positive lead	Negative lead	Result
B	C	Conductive
B	E	Conductive
C	B	Infinite
C	E	Infinite
E	B	Infinite
E	C	Infinite

2SA1294 (PNP)

Positive lead	Negative lead	Result
B	C	Infinite
B	E	Infinite
C	B	Conductive
C	E	Infinite
E	B	Conductive
E	C	Infinite

Calibrations and Adjustments

Bias adjustment:

Note: Bias adjustment should be made without any load connected to the amplifier's output, and no signal connected to the amplifier's input.

1. Connect a multimeter to R137 leads and set the multimeter to mV scale.
2. Turn trimpot RV102 counterclockwise until it reaches 0Ω. A click should be heard.
3. Turn on amplifier, and let it warm up for 15 minutes on idle.
4. Adjust trimpot RV102 to get a 14mV reading.
5. Let the amplifier warm up for a 24 hours period with signal and load.
6. Remove signal and load, and reconnect the multimeter, setted to mV scale, to R120 leads. Note the reading.
7. Connect the multimeter to R137, R138 and R139 leads. Note the readings.
8. Input the results into this formula:
$$((72 - mV_{R137} - mV_{R138} - mV_{R139}) \div 3) + mV_{R137}$$
9. Connect the multimeter to R137 leads, and adjust RV102 to match the reading to the formula result.
10. Results should be around 24mV.

DC offset:

Note: DC offset adjustment should be made without any load connected to the amplifier's output, and no signal connected to the amplifier's input.

1. Connect a multimeter to the output binding posts and set the multimeter to mV scale.
2. Adjust trimpot RV101 in order to reach 0mV. It is easier to turn the trimpot ½ turn at a time, and let DC offset stabilize in order to get an accurate reading.
3. A tolerance of ± 1mV is acceptable.

Parts List

This is not a detailed part list. It is a list of major chassis parts and PCBs. If you need to order a specific part, please contact Classe Audio with the part location, PCB number, and model and serial number of the unit. If you need a complete PCB, please replace the (x) in the Classe part number with the revision number printed on the board.

Parts	Description	Classe part number
B01GX	Complete PCB, filter	B01GXR(x)
B041X	Complete PCB, main	B041XR(x)
B042X	Complete PCB, supply	B042XR(x)
B043X	Complete PCB, capacitor	B043XR(x)

Updates

1. On board B041X, replace R132 and R232 with Classe part number A211-1004.
2. On chassis, install PCB filter (noise elimination module) B01GX, using the following instructions.

Noise elimination module:



EXTRA PRECAUTIONS SHOULD BE TAKEN WHEN REPAIRING, MODIFYING, OR TROUBLESHOOTING IN THE POWER SUPPLY AREA. UNIT MUST BE DISCONNECT FROM MAIN SOURCE AND CAPACITORS MUST BE DISCHARGED USING A 100W INCANDESCENT BULB.

1. Remove top cover, handles and faceplate (for more information about mechanical disassembly and reassembly, report to section 2, mechanical assembly)
2. Turn the unit upside down, front of the unit facing you
3. Using a pencil, make a mark at 3½" from the back of the unit, 5½" from the ride side. Use a punch to guide the drill bit.
4. Using a 1/8" drill bit, drill a hole at this intersection. Clean the area for any metal residue.
5. Remove two black screws holding the voltage selector PCB
6. Disconnect the wire from N (neutral). The wire should be yellow or clear. Take time to identify each wire in order to reconnect them properly.
7. Disconnect wire from L (live). The wire should be blue or black. Identify this wire.
8. Gently strip off the black shrink tubing covering both wires.
9. Cut N wire about 4 inches (10.2cm) from the edge of the lower portion of the supply PCB
10. Connect N wire to one end of the noise filter board, Classe part number B01GXR01. (Fig. 1)
11. Using the wire supplied with the kit, connect the other end of the noise filter board. (Fig. 1)
12. Fix the board to the chassis, using the screws supplied with the kit.
13. Install the heat shrink tubing supplied on N (new wire) and L wires
14. Reconnect both wires to the voltage selector PCB
15. Clean and spotcheck connections
16. Reassemble and test unit carefully for proper operation.

Updates

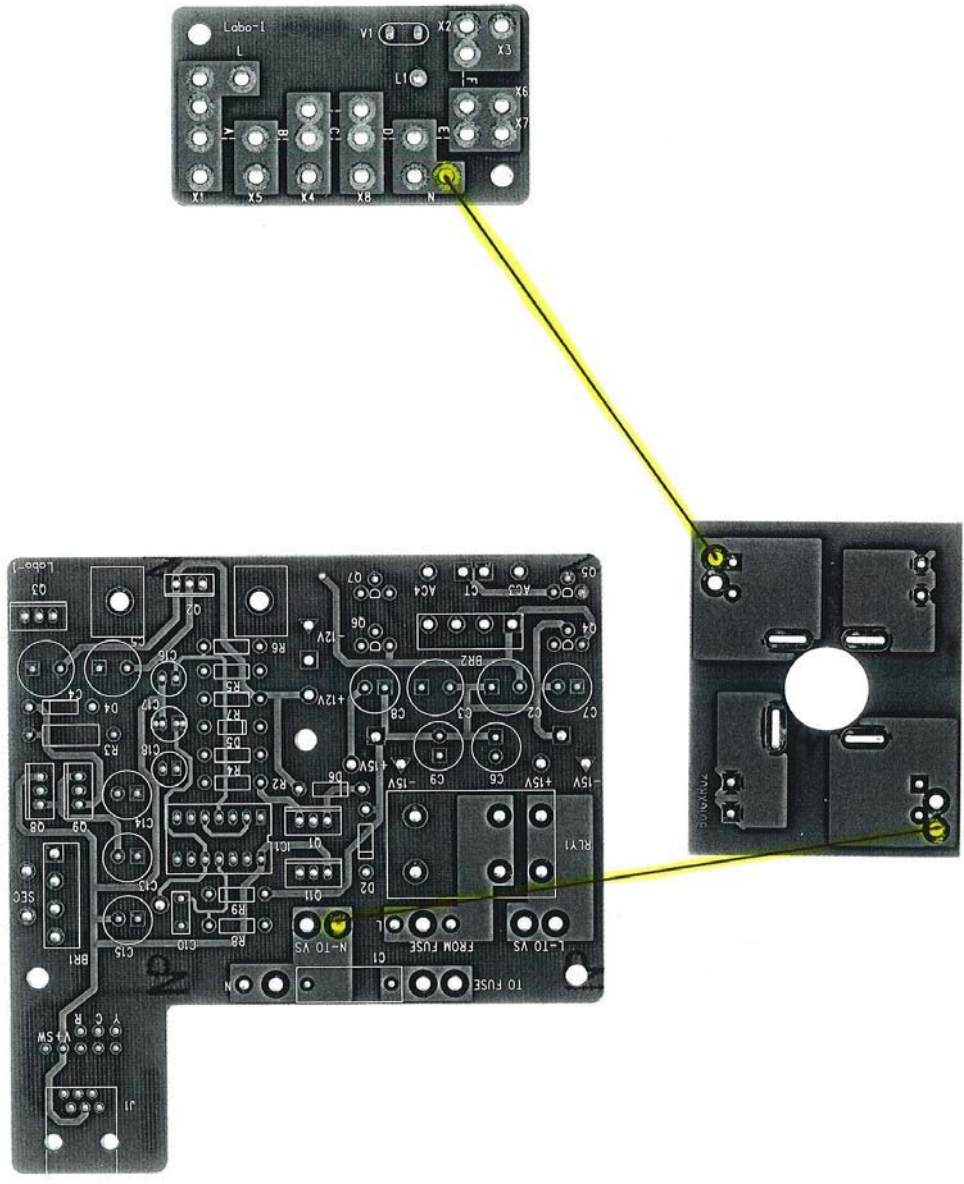

fig. 1

Fuses



EXTRA PRECAUTIONS SHOULD BE TAKEN WHEN REPAIRING, MODIFYING, OR TROUBLESHOOTING IN THE POWER SUPPLY AREA. UNIT MUST BE DISCONNECT FROM MAIN SOURCE AND CAPACITORS MUST BE DISCHARGED USING A 100W INCANDESCENT BULB.



WHEN REPLACING FUSES, PLEASE MAKE SURE THAT THE FUSE HOLDERS ARE HOLDING THE FUSES VERY TIGHTLY. A LOOSE FUSE HOLDER CAN TRANSLATE INTO DISTORTION ON TOP OF THE SIGNAL.

Main fuses:

For 100 – 120v units: 8A slo-blo, Classe part number MDL-8A

For 220 – 240v units: 6A slo-blo, Classe part number MDL-6A

The main fuse is located at the back of the unit, on the rear panel.

Rail fuses: 5A, Classe part number GDB-5A

The rail fuses are located on the capacitor boards.

Voltage Change



EXTRA PRECAUTIONS SHOULD BE TAKEN WHEN REPAIRING, MODIFYING, OR TROUBLESHOOTING IN THE POWER SUPPLY AREA. UNIT MUST BE DISCONNECT FROM MAIN SOURCE AND CAPACITORS MUST BE DISCHARGED USING A 100W INCANDESCENT BULB.

1. Set the jumper position according to the table below.
2. Replace the varistor, according to new line voltage, following Classe's recommendations. If varistor is not available, remove old varistor and leave it empty.

Jumper positions, main transformer

Mains	Jumper 1	Jumper 2	Jumper 3	Varistor
100VAC	A	E	F	221
120VAC	A	C	D	221
220VAC	B	E	-	391 / 441
240VAC	B	D	-	391 / 441

Remote Interface Information

The CA150-151 can be turned on or off using a simple interface connected to the Remote jack, located at the back of the unit.

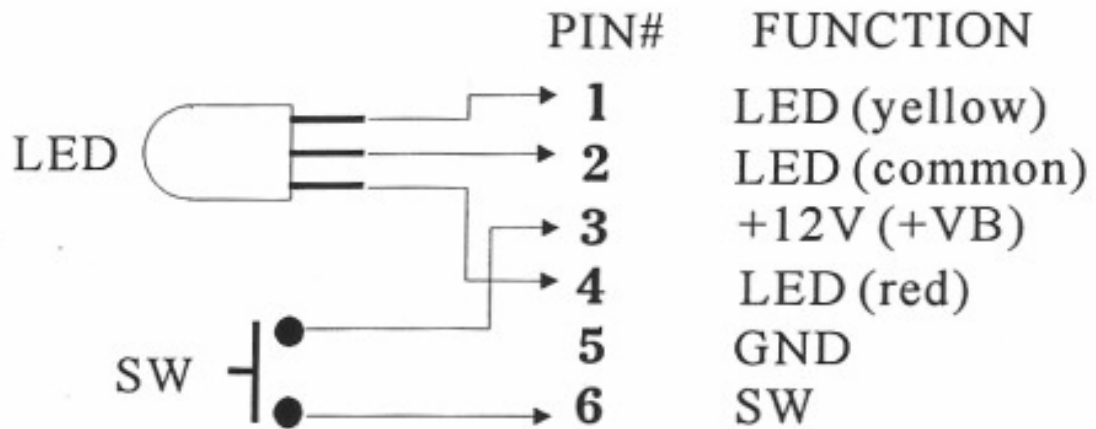
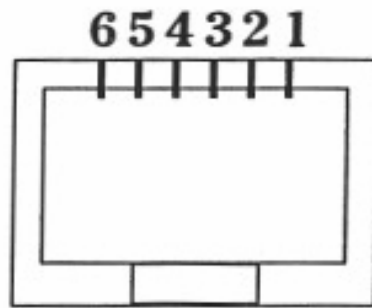

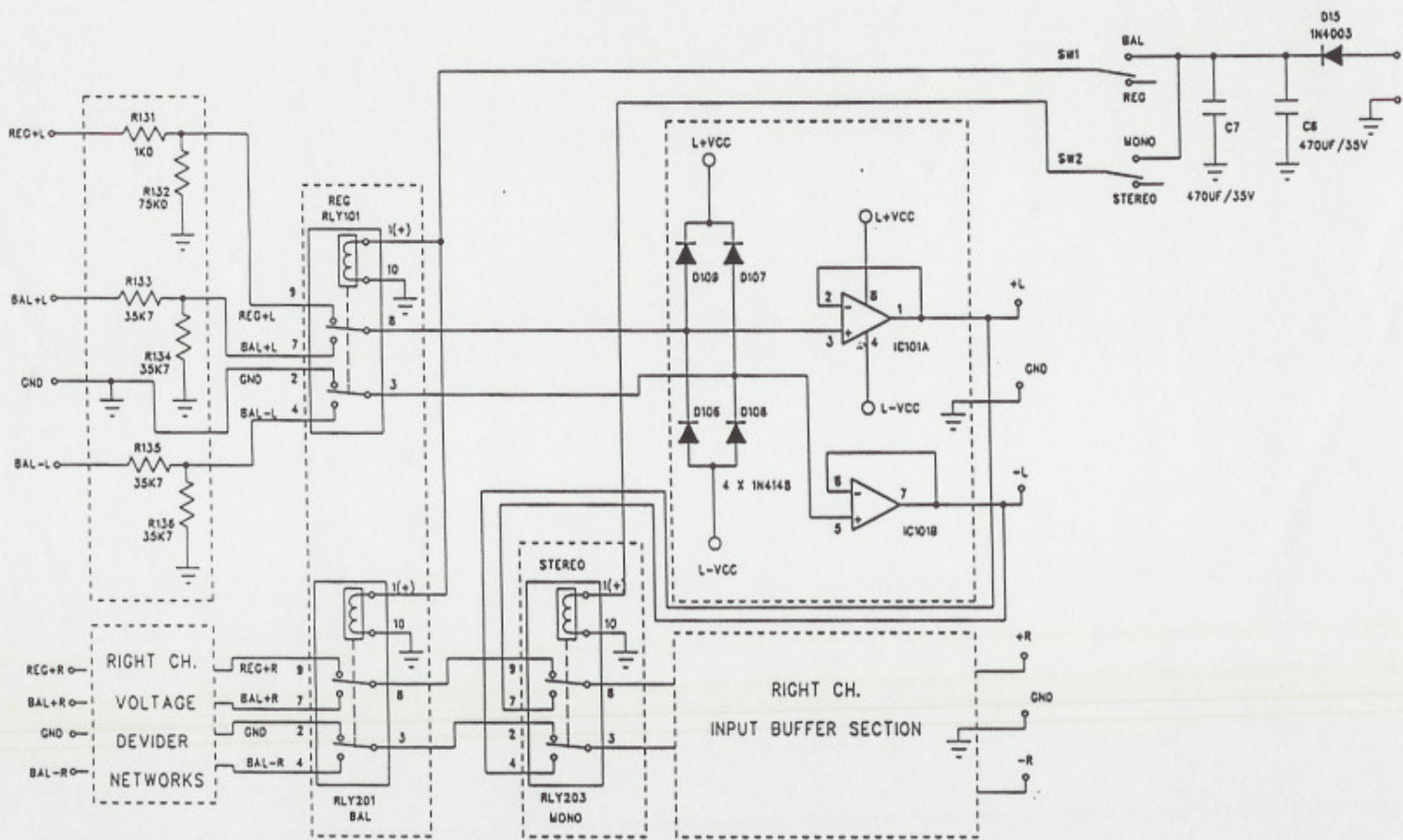

REGULAR/STEREO POSITION SHOWN (DEFAULT)

NOTE: CORRESPONDING PART NAMES ON RIGHT CHANNEL: R2XX, C2XX, D2XX, etc..

COMPANY:	CLASSE AUDIO INC.
TITLE:	CA-150 POWER AMPLIFIER
DESC:	INPUT BUFFER SECTION
DRAWING NO:	01506W1
DRAWN:	NYK
DATE:	JUN 01/94
SHEET:	1 OF 6

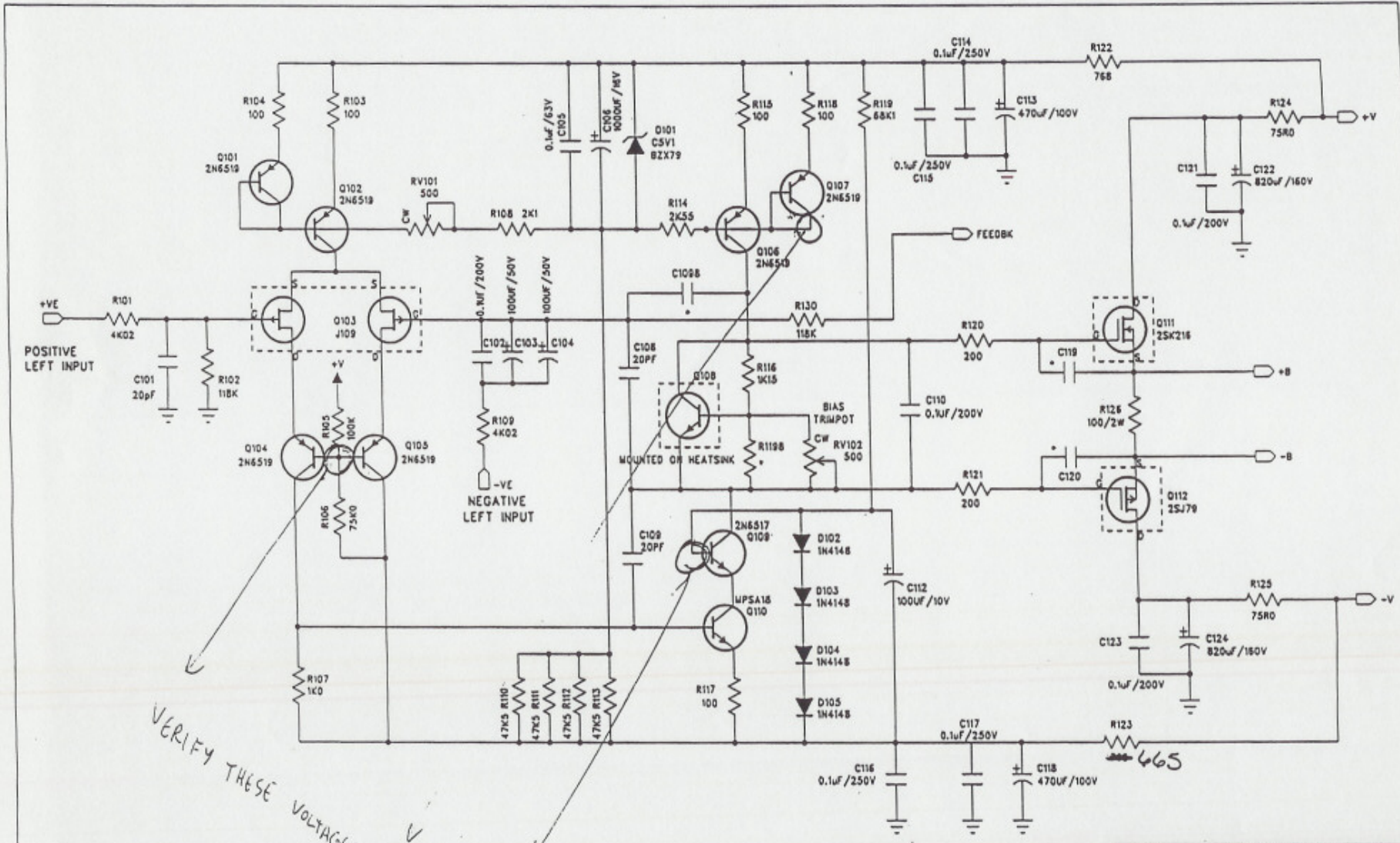

LEFT CHANNEL SHOWN

* = INSTALLED DURING CALIBRATION
 CORRESPONDING PART NAMES ON RIGHT CHANNEL: R2XX, C2XX, D2XX, etc..

COMPANY:	CLASSE AUDIO INC.
TITLE:	CA-150 POWER AMPLIFIER
DESC:	LEFT CHANNEL CIRCUITRY
DRAWING NO:	015062R1
DRAWN:	NYK
DATE:	JUN 01/94
SHEET:	2 OF 6

FUSE VALUES:
 100-120VAC: 8A SLO-BLO
 220-240VAC: 6A SLO-BLO

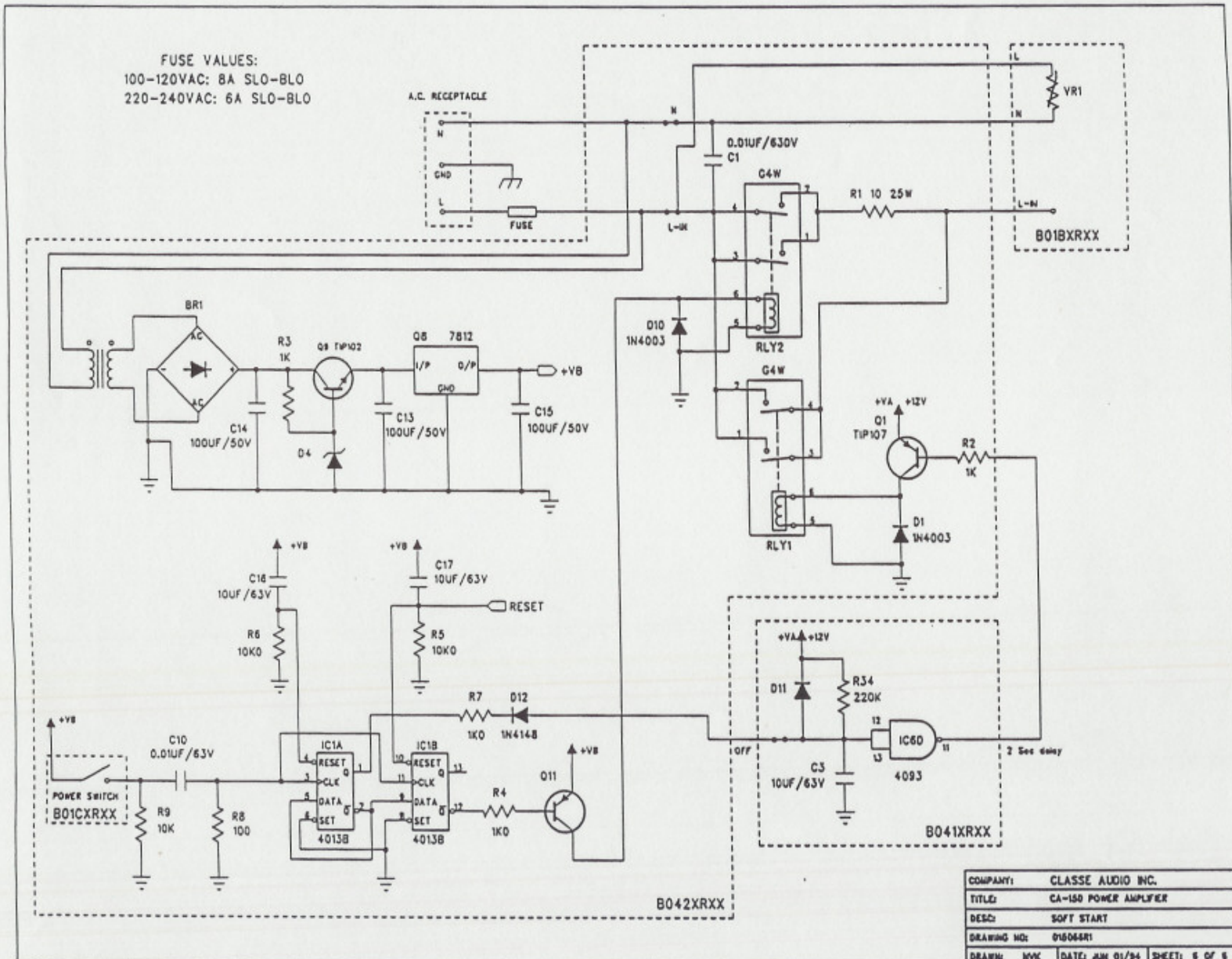

COMPANY:	CLASSE AUDIO INC.
TITLE:	CA-150 POWER AMPLIFIER
DESC:	SOFT START
DRAWING NO:	015048R1
DRAWN:	MVC
DATE:	JUN 01/84
SHEET:	6 OF 6

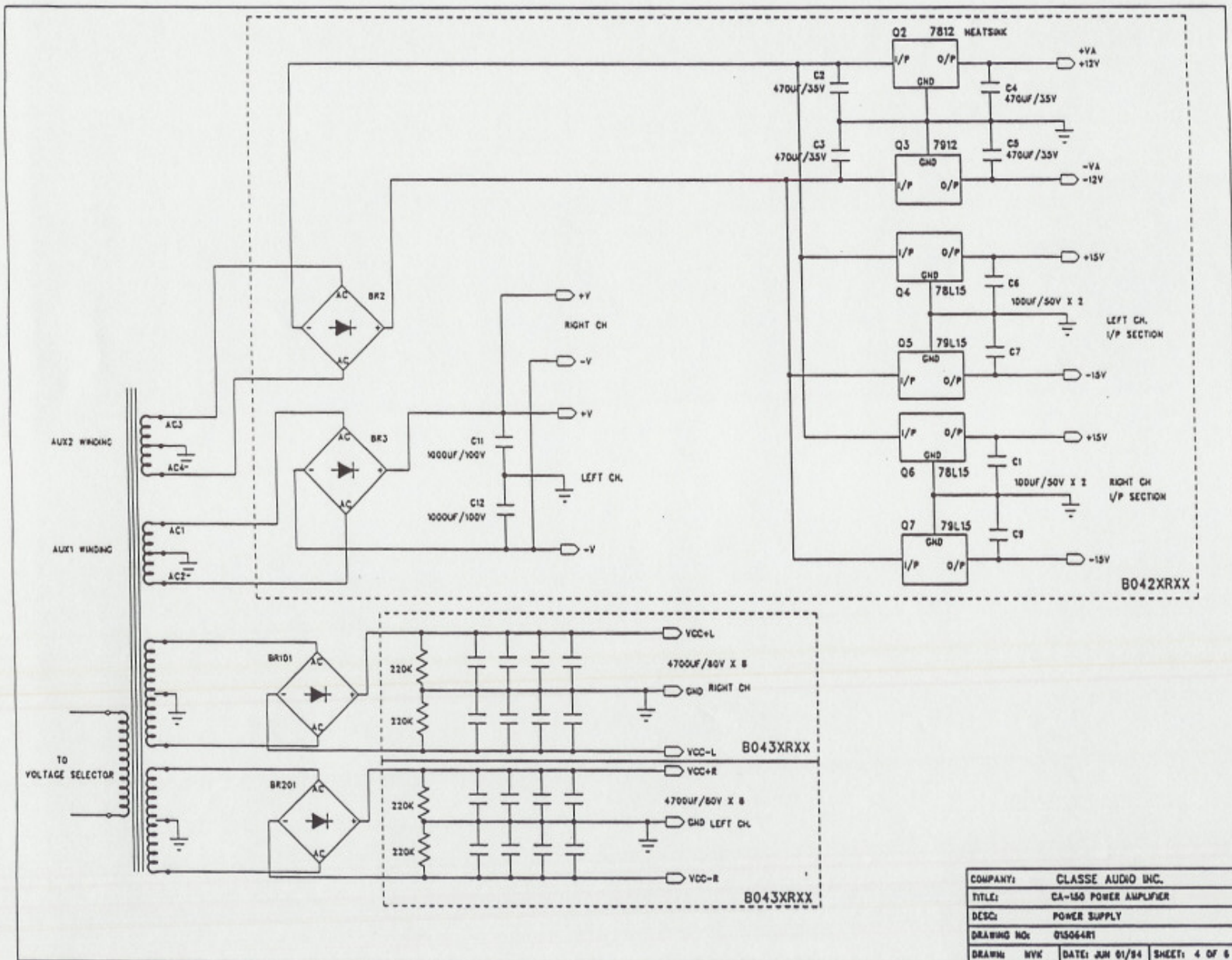

COMPANY:	CLASSE AUDIO INC.
TITLE:	CA-150 POWER AMPLIFIER
DESC:	POWER SUPPLY
DRAWING NO:	015064RT
DRAWN:	HYK
DATE:	JUN 01/84
SHEET:	4 OF 6

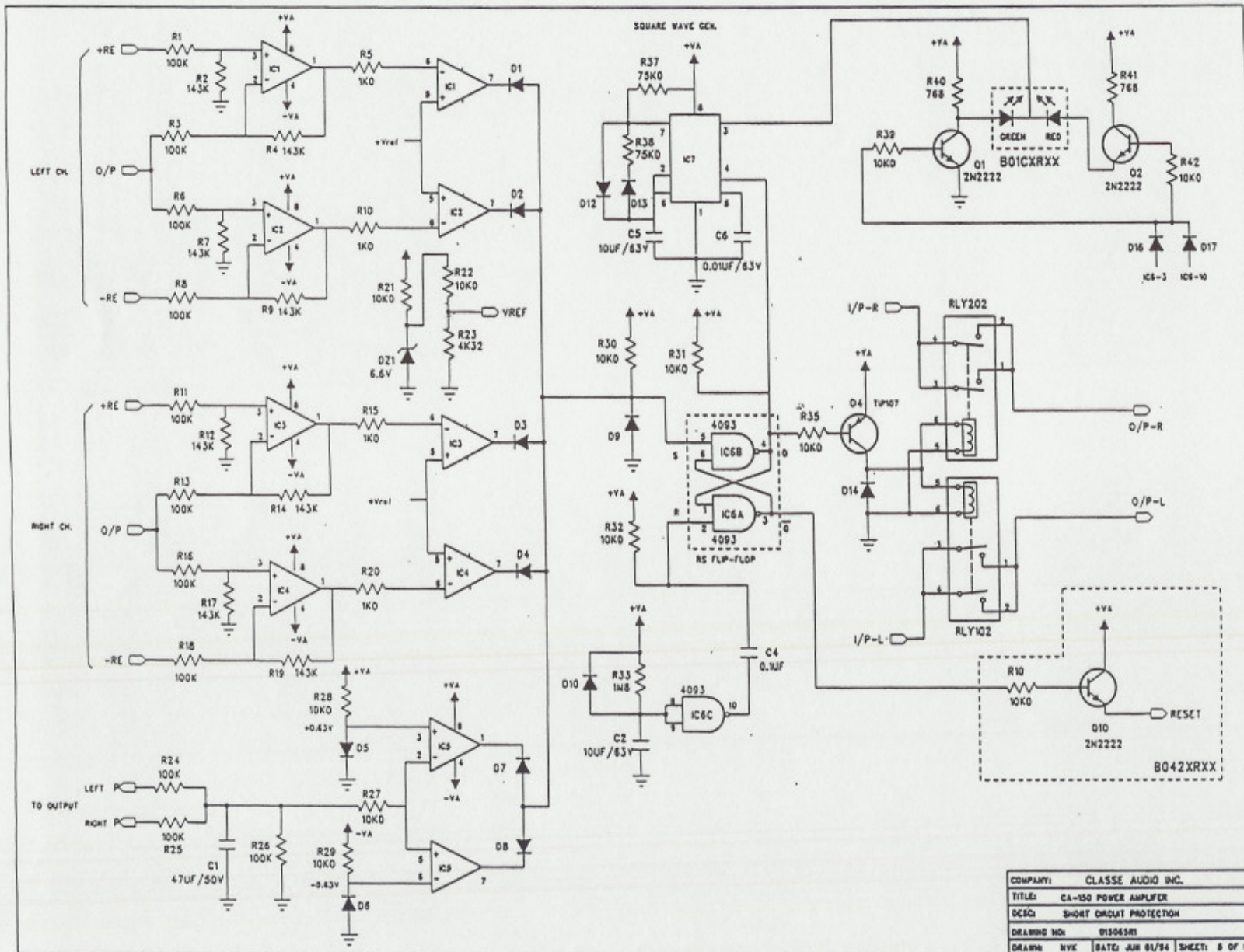

COMPANY:	CLASSE AUDIO INC.
TITLE:	CA-150 POWER AMPLIFIER
DESC:	SHORT CIRCUIT PROTECTION
DRAWING NO:	015065R1
DRAWN BY:	NVE
DATE:	JUN 81/84
SHEET:	6 OF 6

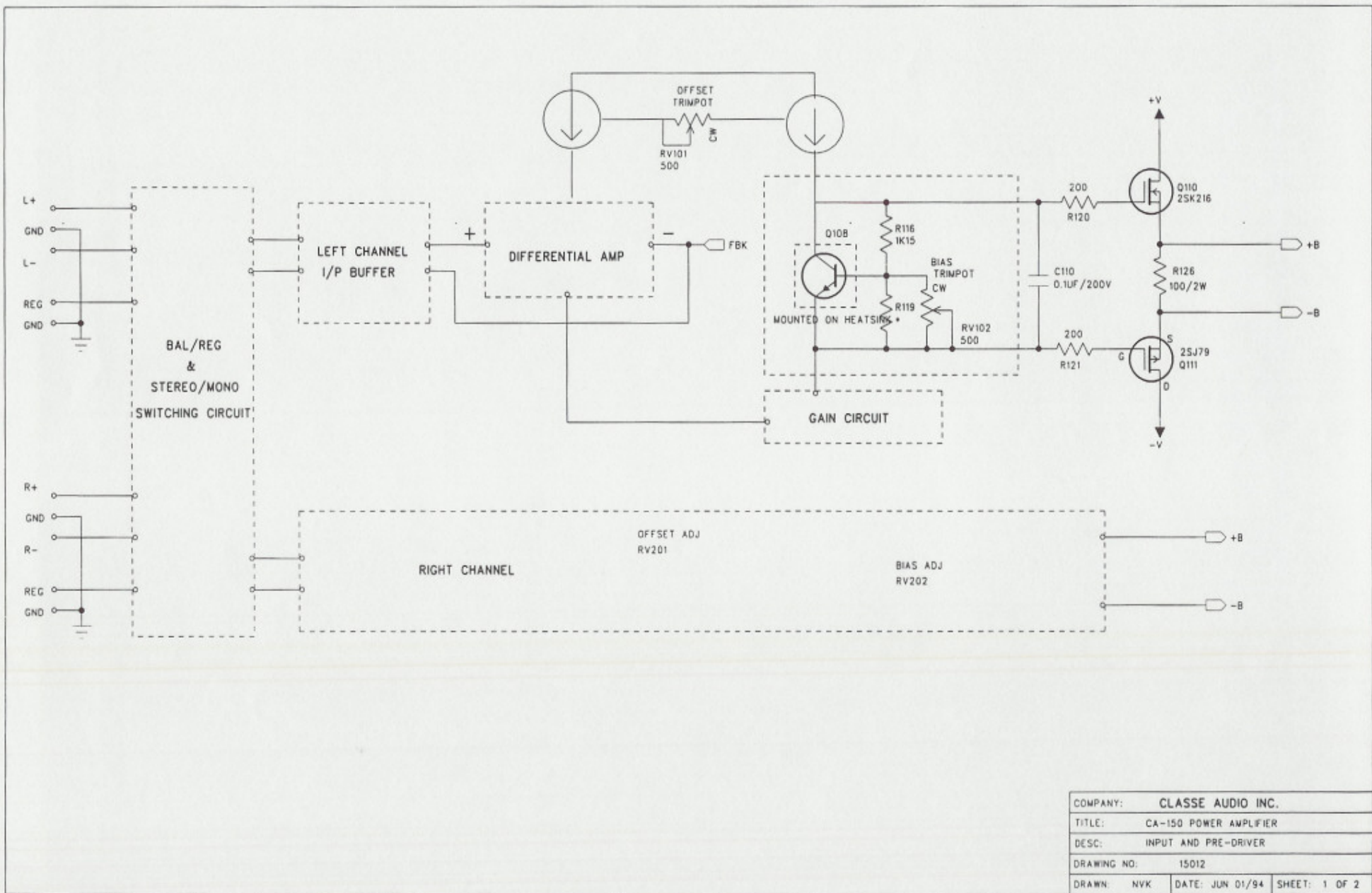

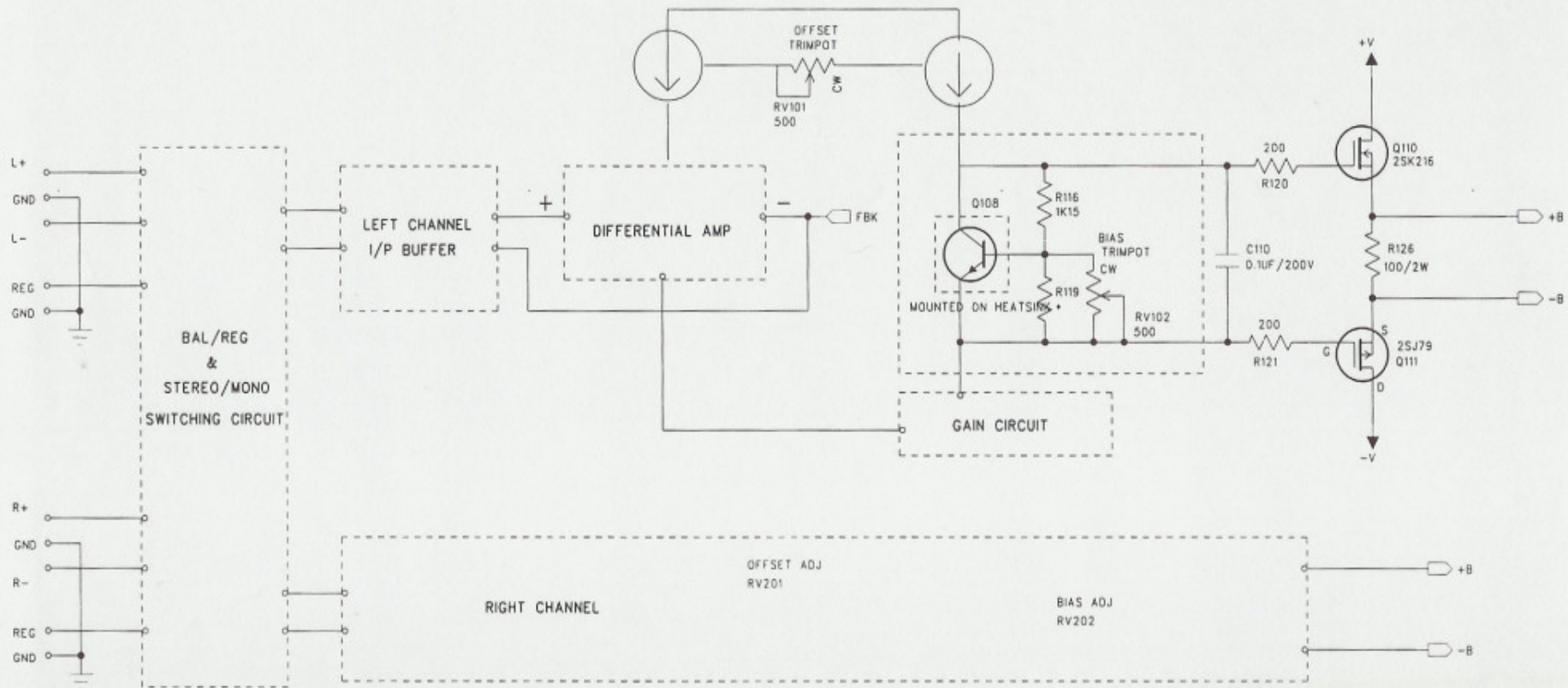

COMPANY:	CLASSE AUDIO INC.		
TITLE:	CA-150 POWER AMPLIFIER		
DESC:	INPUT AND PRE-DRIVER		
DRAWING NO:	15012		
DRAWN:	NVK	DATE:	JUN 01/94
		SHEET:	1 OF 2

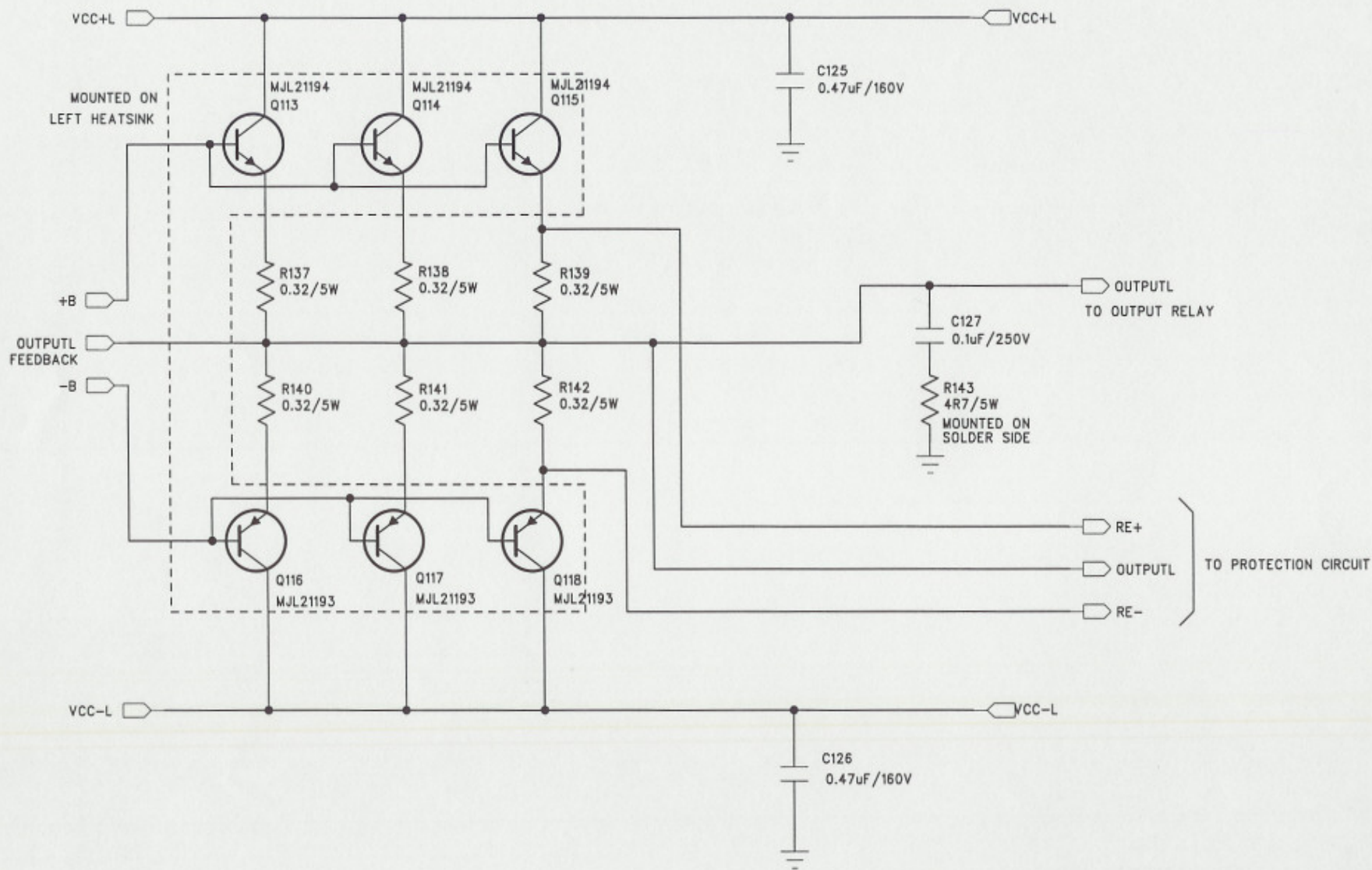

LEFT CHANNEL SHOWN

* = INSTALLED DURING CALIBRATION
 CORRESPONDING PART NAMES ON RIGHT CHANNEL: R2XX, C2XX, D2XX, etc..

COMPANY:	CLASSE AUDIO INC.	
TITLE:	CA-150 POWER AMPLIFIER	
DESC:	OUTPUT SECTION	
DRAWING NO:	15022	
DRAWN:	NVK	DATE: JUN 01/94 SHEET: 2 OF 2