

# Audio Applications of Linear Integrated Circuits

National Semiconductor  
Application Note 299



AN-299

Although operational amplifiers and other linear ICs have been applied as audio amplifiers, relatively little documentation has appeared for other audio applications. In fact, a wide variety of studio and industrial audio areas can be served by existing linear devices. The stringent demands of audio requirements often mean that unusual circuit configurations must be used to satisfy a requirement. By combining off-the-shelf linear devices with thoughtful circuit designs, low cost, high performance solutions are achievable. An example appears in *Figure 1*.

## EXPONENTIAL V-F CONVERTER

Studio-type music synthesizers require an exponentially responding V-F converter with a typical scale factor of 1V in per octave of frequency output. Exponential conformity requirements must be within 0.5% from 20 Hz-15 kHz. Almost all existing designs utilize the logarithmic relationship between  $V_{BE}$  and collector current in a transistor.

Although this method works well, it requires careful attention to temperature compensation to achieve good results. *Figure 1* shows a circuit which eliminates all temperature compensation requirements. In this circuit, the current into A1's summing junction is exponentially related to the circuit input voltage because of the logarithmic relationship between Q1's  $V_{BE}$  and its collector current. A1's output integrates negatively until the Q2-Q5 pair comes on and resets A1 back to 0V. Note that opposing junction tempcos in Q2 and Q5 provide a temperature compensated switching threshold with a small (100 ppm/ $^{\circ}$ C) drift. The -120 ppm/ $^{\circ}$ C drift of the polystyrene integrating capacitor effectively cancels this residual term. In this fashion, A1's output provides the sawtooth frequency output. The LM329 reference stabilizes the Q5-Q2 firing point and also fixes Q1's collector bias. The 3k resistor establishes a 20 Hz output frequency for 0V input, while the 10.5k unit trims the gain to 1V in per octave frequency doubling out. Exponential conformity is within 0.25% from 20 Hz to 15 kHz.

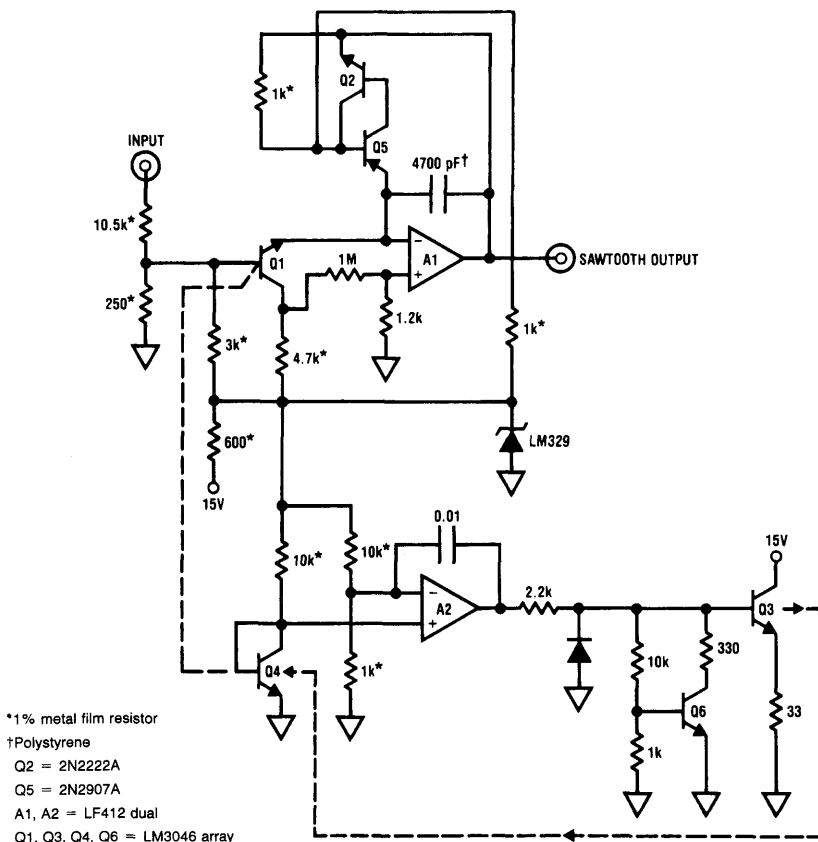

\*1% metal film resistor  
†Polystyrene  
Q2 = 2N2222A  
Q5 = 2N2907A  
A1, A2 = LF412 dual  
Q1, Q3, Q4, Q6 = LM3046 array

FIGURE 1

TL/H/7496-1

The 1M–1.2k divider at A1's "+" input achieves first order compensation for Q1's bulk emitter resistance, aiding exponential conformity at high frequencies. A2 and its associated components are used to "brute-force" stabilize Q1's operating point. Here, Q3, Q4 and A2 form a temperature-control loop that thermally stabilizes the LM3046 array, of which Q1 is a part. Q4's  $V_{BE}$  senses array temperature while Q3 acts as the chip's heater. A2 provides servo gain, forcing Q4's  $V_{BE}$  to equal the servo temperature setpoint established by the 10k–1k string. Bias stabilization comes from the LM329. The Q6 clamp and the 33 $\Omega$  emitter resistor determine the maximum power Q3 can dissipate and also prevent servo lock-up during circuit start-up. Q1, operating in this tightly controlled environment, is thus immune from effects of ambient temperature shift.

#### ULTRA-LOW FEEDTHROUGH VOLTAGE-CONTROLLED AMPLIFIER

A common studio requirement is a voltage-controlled gain amplifier. For recording purposes, it is desirable that, when the gain control channel is brought to 0V, the signal input feedthrough be as low as possible. Standard configurations use analog multipliers to achieve the voltage-controlled gain function. In Figure 2, A1–A4, along with Q1–Q3, comprise such a multiplier, which achieves about –65 dB of feedthrough suppression at 10 kHz. In this arrangement, A4 single ends a transconductance type multiplier composed

of A3 along with Q1 and Q2. A1 and A2 provide buffered inputs. The –65 dB feedthrough figure is typical for this type of multiplier. A5 and A6 are used to further reduce this feedthrough figure to –84 dB at 20 kHz by a nulling technique. Here, the circuit's audio input is inverted by A5 and then summed at A6 with the main gain control output, which comes from A4. The RC networks at A5's input provide phase shift and frequency response characteristics which are the same as the main gain control multipliers feedthrough characteristics. The amount of feedthrough compensation is adjusted with the 50k potentiometer. In this way, the feedthrough components (and only the feedthrough components) are nulled out and do not appear at A6's output. From 20 Hz to 20 kHz, feedthrough is less than –80 dB. Distortion is inside 0.05%, with a full power bandwidth of 60 kHz. To adjust this circuit, apply a 20 Vp-p sine wave at the audio input and ground the gain control input. Adjust the 5k coarse feedthrough trim for minimum output at A4. Next, adjust the 50k fine feedthrough trim for minimum output at A6. For best performance, this circuit must be rigidly constructed and enclosed in a fully shielded box with attention given to standard low noise grounding techniques. Figure 3 shows the typical remaining feedthrough at 20 kHz for a 20 Vp-p input. Note that the feedthrough is at least –80 dB down and almost obscured by the circuit noise floor.

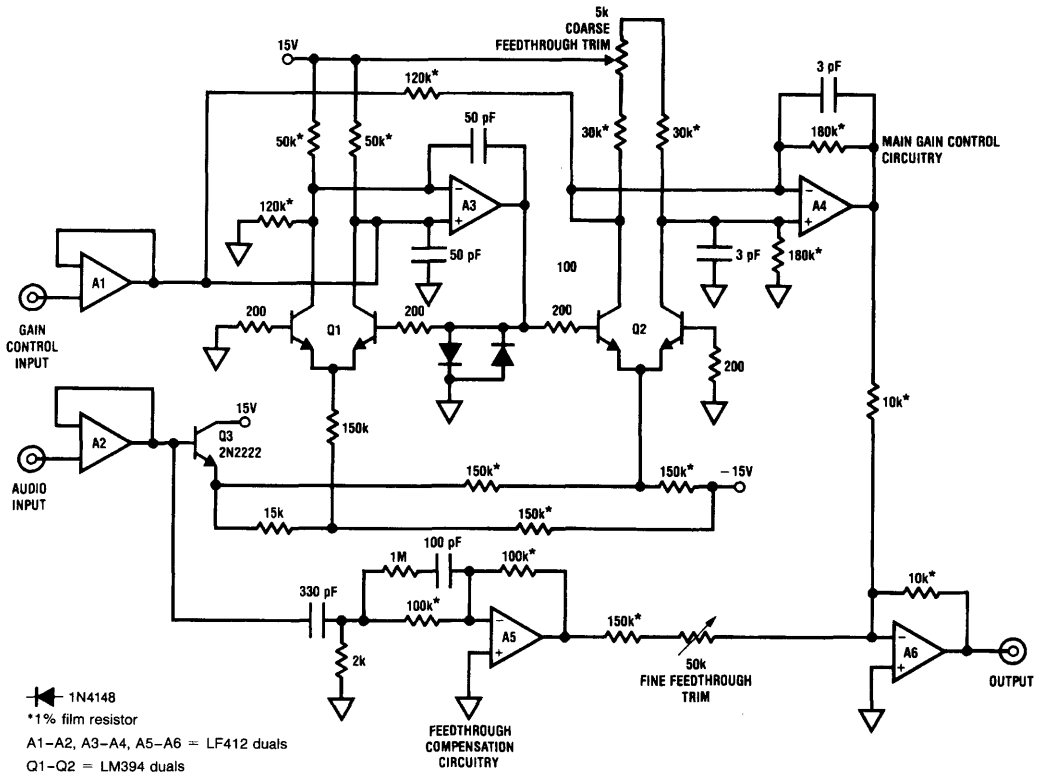

FIGURE 2

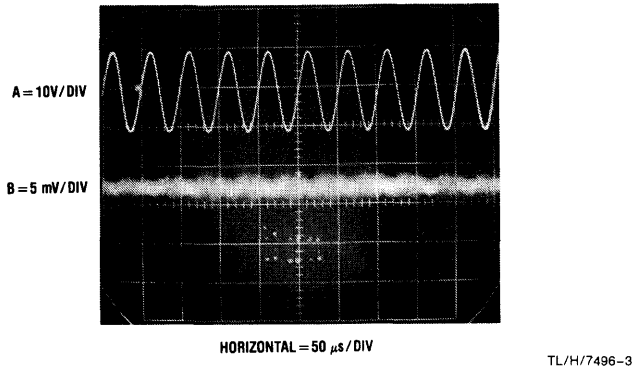
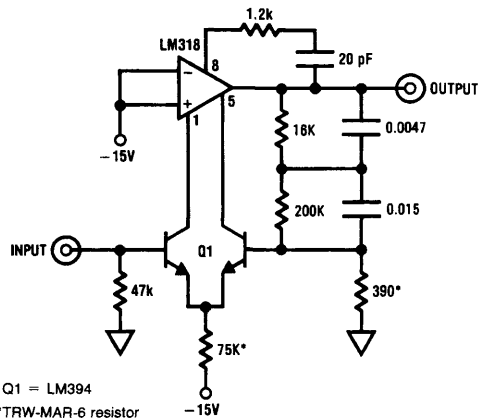

FIGURE 3



Frequency	Total Harmonic Distortion				
	<0.002	<0.002	<0.002	<0.002	<0.002
20	<0.002	<0.002	<0.002	<0.002	<0.002
100	<0.002	<0.002	<0.002	<0.002	<0.002
1000	<0.002	<0.002	<0.002	<0.002	<0.002
10000	<0.002	<0.002	<0.002	<0.0025	<0.003
20000	<0.002	<0.002	<0.004	<0.004	<0.007
<b>Output Amplitude (Vrms)</b>	0.03	0.1	0.3	1.0	5.0

TL/H/7496-4

FIGURE 4

**ULTRA-LOW NOISE RIAA PREAMPLIFIER**

In Figure 4, an LM394 is used to replace the input stage of an LM118 high speed operational amplifier to create an ultra-low distortion, low noise RIAA-equalized phono preamplifier. The internal input stage of the LM118 is shut off by tying the unused input to the negative supply. This allows the LM394 to be used in place of the internal input stage, avoiding the loop stability problems created when extra stages are added. The stability problem is especially critical in an RIAA circuit where 100% feedback is used at high frequencies. Performance of this circuit exceeds the ability of most test equipment to measure it. As shown in the accompanying chart, harmonic distortion is below the measurable 0.002% level over most of the operating frequency and amplitude range. Noise referred to a 10 mV input signal is -90 dB down, measuring 0.55 μVrms and 70 pArms in a 20 kHz bandwidth. More importantly, the noise figure is less

than 2 dB when the amplifier is used with standard phono cartridges, which have an equivalent wideband (20 kHz) noise of 0.7 μV. Further improvements in amplifier noise characteristics would be of little use because of the noise generated by the cartridge itself. A special test was performed to check for transient intermodulation distortion. 10 kHz and 11 kHz were mixed 1:1 at the input to give an rms output voltage of 2V (input = 200 mV). The resulting 1 kHz intermodulation product measured at the output was 80 μV. This calculates to 0.0004% distortion, quite a low level, considering that the 1 kHz has 14 dB (5:1) gain with respect to the 10 kHz signal in an RIAA circuit. Of special interest also is the use of all DC coupling. This eliminates the overload recovery problems associated with coupling and bypass capacitors. Worst-case DC output offset voltage is about 1V with a cartridge having 1 kΩ DC resistance.

**MICROPHONE PREAMPLIFIER**

Figure 5 shows a microphone preamplifier which runs from a single 1.5V cell and can be located right at the microphone. Although the LM10 amplifier-reference combination has relatively slow frequency response, performance can be considerably improved by cascading the amplifier and reference amplifier together to form a single overall audio amplifier. The reference, with a 500 kHz unity-gain bandwidth, is used as a preamplifier with a gain of 100. Its output is fed through a gain control potentiometer to the op amp, which is connected for a gain of 10. The combination gives a 60 dB gain with a 10 kHz bandwidth, unloaded, and 5 kHz, loaded with 500Ω. Input impedance is 10 kΩ.

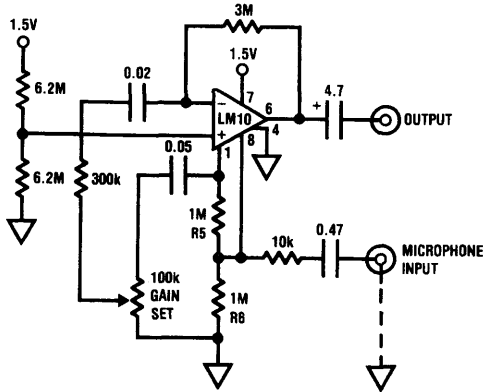

FIGURE 5

TL/H/7496-5

Potentially, using the reference as a preamplifier in this fashion can cause excess noise. However, because the reference voltage is low, the noise contribution which adds root-mean-square, is likewise low. The input noise voltage in this connection is 40 nV–50 nV/√Hz, approximately equal to that of the op amp.

One point to observe with this connection is that the signal swing at the reference output is strictly limited. It cannot swing much below 150 mV, nor closer than 800 mV to the supply. Further, the bias current at the reference feedback terminal lowers the output quiescent level and generates an uncertainty in this level. These facts limit the maximum feedback resistance (R5) and require that R6 be used to optimize the quiescent operating voltage on the output. Even so, one must consider the fact that limited swing on the preamplifier can reduce maximum output power with low settings on the gain control.

In this design, no DC current flows in the gain control. This is perhaps an arbitrary rule, designed to insure long life with noise-free operation. If violations of this rule are acceptable, R5 can be used as the gain control with only the bias current for the reference amplifier (<75 nA) flowing through the wiper. This simplifies the circuit and gives more leeway in getting sufficient output swing from the preamplifier.

**DIGITALLY PROGRAMMABLE PANNER-ATTENUATOR**

Figure 6 shows a simple, effective way to use a multiplying CMOS D-A converter to steer or pan an audio signal between two channels. In this circuit, the current outputs of the DAC1020, which are complementary, each feed a current-to-voltage amplifier. The amplifiers will have complementary voltage outputs, the amplitude of which will depend upon

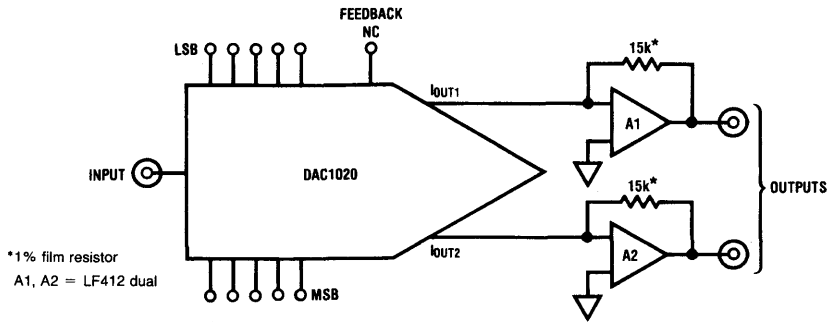

FIGURE 6

TL/H/7496-6

the address code to the DAC's digital inputs. *Figure 7* shows the amplifier outputs for a ramp-count code applied to the DAC digital inputs. The 1.5 kHz input appears in complementary amplitude-modulated form at the amplifier outputs. The normal feedback connection to the DAC is not used in this circuit. The use of discrete feedback resistors facilitates gain matching in the output channels, although each amplifier will have a  $\approx 300$  ppm/ $^{\circ}$ C gain drift due to mismatch between the internal DAC ladder resistors and the discrete feedback resistors. In almost all cases, this small error is acceptable, although two DACs digitally addressed in complementary fashion could be used to totally eliminate gain error.

#### DIGITALLY PROGRAMMABLE BANDPASS FILTER

*Figure 8* shows a way to construct a digitally programmable first order bandpass filter. The multiplying DAC's function

is to control cut-off frequency by controlling the gain of the A3–A6 integrators, which has the effect of varying the integrators' capacitors. A1–A3 and their associated DAC1020 form a filter whose high-pass output is taken at A1 and fed to an identical circuit composed of A4–A6 and another DAC. The output of A6 is a low-pass function and the final circuit output. The respective high-pass and low-pass cut-off frequencies are programmed with the DAC's digital inputs. For the component values shown, the audio range is covered.

#### REFERENCES

Application Guide to CMOS Multiplying D-A Converters, Analog Devices, Inc. 1978

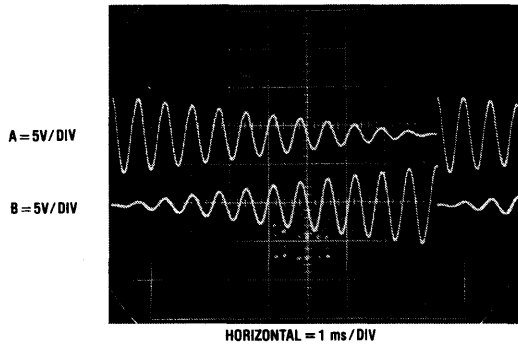

FIGURE 7

TL/H/7496-7

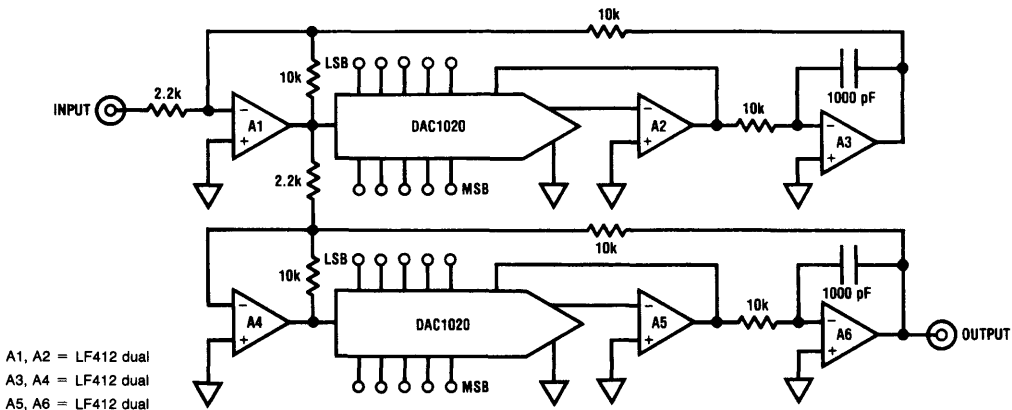

FIGURE 8

TL/H/7496-8