

The LM110 An Improved IC Voltage Follower

National Semiconductor
Linear Brief 11



Robert J. Widlar
Apartado Postal 541
Puerto Vallarta, Jalisco
Mexico

There are quite a few applications where op amps are used as voltage followers. These include sample and hold circuits and active filters as well as general purpose buffers for transducers or other high-impedance signal sources. The general usefulness of such an amplifier is particularly enhanced if it is both fast and has a low input bias current. High speed permits including the buffer in the signal path or within a feedback loop without significantly affecting response or stability. Low input current prevents loading of high impedance sources, which is the reason for using a buffer in the first place.

The LM102, introduced in 1967, was designed specifically as a voltage follower. Therefore, it was possible to optimize performance so that it worked better than general purpose IC amplifiers in this application. This was particularly true with respect to obtaining low input currents along with high-speed operation.

One secret of the LM102's performance is that followers do not require level shifting. Hence, lateral PNP's can be eliminated from the gain path. This has been the most significant

limitation on the frequency response of general purpose amplifiers. Secondly, it was the first IC to use super-gain transistors. With these devices, high speed operation can be realized along with low input currents.

The LM110 is a voltage follower that has been designed to supersede the LM102. It is considerably more flexible in its application and offers substantially improved performance. In particular, the LM110 has lower offset-voltage drift, input current and noise. Further, it is faster, less prone to oscillations and operates over a wider range of supply voltages.

The advantages of the LM110 over the LM102 are described by the following curves. Improvements not included are increased output swing under load, larger small-signal bandwidth, and elimination of oscillations with low-impedance sources. The performance of these devices is also compared with general-purpose op amps in Tables I and II. The advantages of optimizing an IC for this particular slot are clearly demonstrated. Lastly, some typical applications for voltage followers with the performance capability of the LM110 are given.

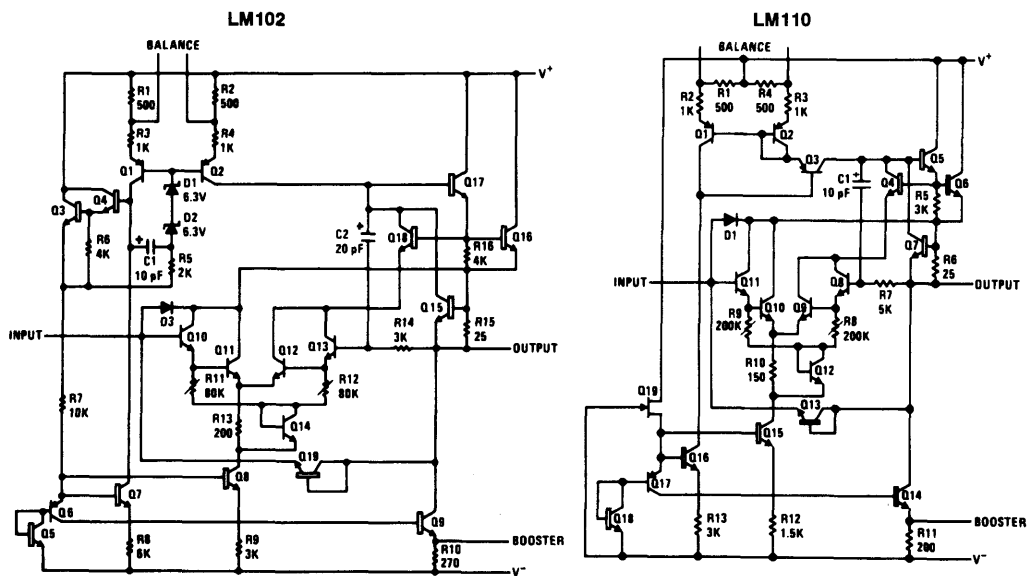

Biggest design difference between the LM102 and LM110 is the elimination of the zener diodes (D1 and D2) in the biasing circuit. This reduces noise and permits operation at low supply voltages.

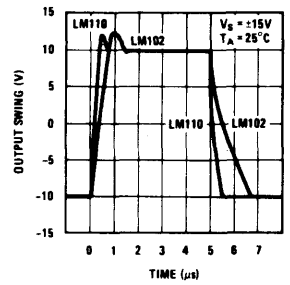
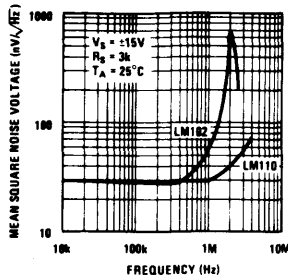
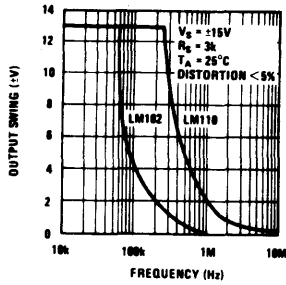

Power bandwidth of the LM110 is five times larger than the LM102.

Eliminating zeners reduces typical high frequency noise by nearly a factor or 10. Worst case noise is reduced even more. High frequency noise of LM102 has caused problems when it was included inside feedback loop with other IC op amps.

Large signal pulse response shows 40V/µs slew for LM110 and 10V/µs for LM102. Leading edge overshoot on LM110 is virtually eliminated, so external clamp diode frequently required on the LM102 is not needed.

TL/H/8462-3

Table I. Comparing performance of military grade IC op amps in the voltage-follower connection

Device	Offset** Voltage (mV)	Bias** Current (nA)	Slew† Rate (V/µs)	Bandwidth† (MHz)	Supply* Current (mA)
LM110	6.0	10	40	20	5.5
LM102	7.5	100	10	10	5.5
MC1556	6.0	30	2.5	1	1.5
µA715	7.5	4000	20	10	7.0
LM108	3.0	3	0.3	1	0.6
LM108A	1.0	3	0.3	1	0.6
LM101A	3.0	100	0.6	1	3.0
µA741	6.0	1500	0.6	1	3.0

**Maximum for -55°C ≤ T_A ≤ 125°C

*Maximum at 25°C

†Typical at 25°C

Table II. Comparison of commercial grade devices

Device	Offset* Voltage (mV)	Bias* Current (nA)	Slew† Rate (V/µs)	Bandwidth† (MHz)	Supply* Current (mA)
LM310	7.5	7.0	40	20	5.5
LM302	15	30	20	10	5.5
MC1456	10	30	2.5	1	1.5
µA715C	7.5	1500	20	10	10
LM308	7.5	7.0	0.3	1	0.8
LM308A	0.5	7.0	0.3	1	0.8
LM301A	7.5	250	0.6	1	3.0
µA741C	6.0	500	0.6	1	3.0

*Maximum at 25°C

†Typical at 25°C

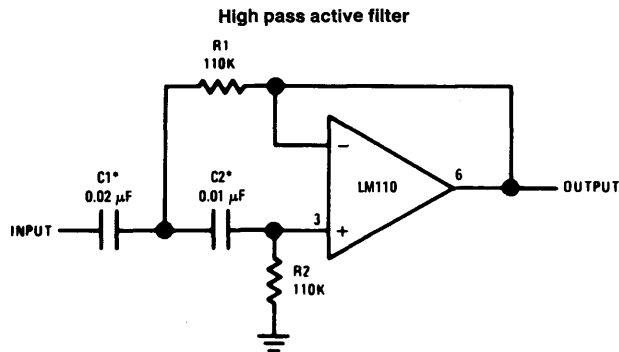

*Values are for 100 Hz cutoff. Use metallized polycarbonate capacitors for good temperature stability

TL/H/8462-4

High Q Notch Filter

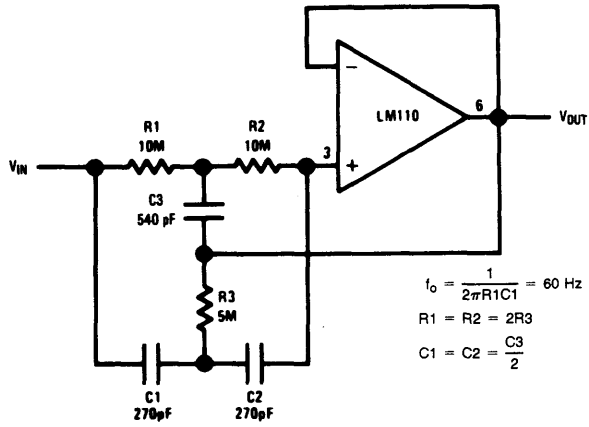

Low Drift Sample and Hold*

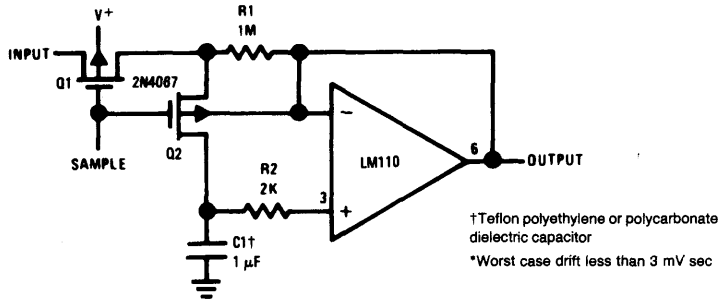

Bandpass Filter

