

## Home-security brain

# 12

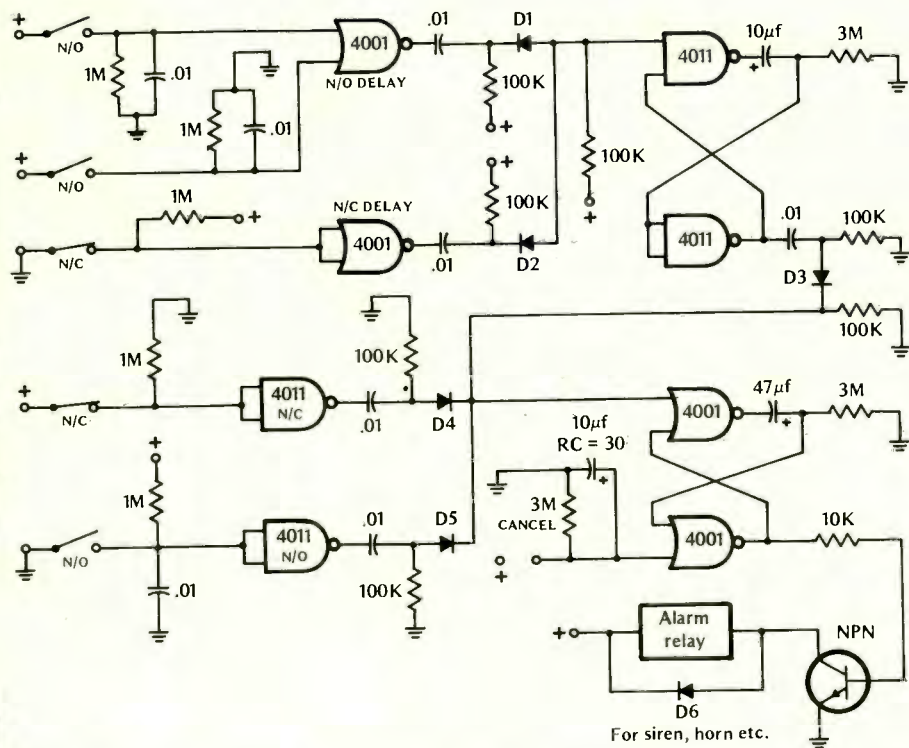

Get a loud blast of sound for your home security monitoring system for protection against forced entry by burglars. Battery powered, the unit is on duty even during power failures. Standby current drain is so low the batteries will perform for their shelf life. The circuit shown provides both normally open contacts (NO), such as fail-safe magnetic door switches, and normally closed contacts (NC), such as window tape. The two lower switches provide instantaneous operation. The three upper switches turn on the alarm after a 30-second delay, giving you time to turn off the system by closing the "cancel" switch.

If you use a reed relay to activate your alarm, a 2N2222 or 2N3904 transistor can be used. Otherwise, any NPN transistor with a current rating high enough to power the relay you use will work.