

LITTLE DOOR GUARD

■ T.K. HAREENDRAN

If some intruder tries to open the door of your house, this circuit sounds an alarm to alert you against the attempted intrusion.

The circuit (Fig. 1) uses readily available, low-cost components. For compactness, an alkaline 12V battery is used for powering the unit. Input DC supply is further regulated to a steady DC voltage of 5V by 3-pin regulator IC 7805 (IC2).

Assemble the unit on a general-purpose PCB as shown in Fig. 4 and mount the same on the door as shown in Fig. 3. Now mount a piece of mirror on the doorframe such that it is exactly aligned with the unit. Pin configurations of IC UM3561 and transistors 2N5777 and BC547 are shown in Fig. 2.

Initially, when the door is closed, the infrared (IR) beam transmitted by IR LED1 is reflected (by the mirror) back to phototransistor 2N5777

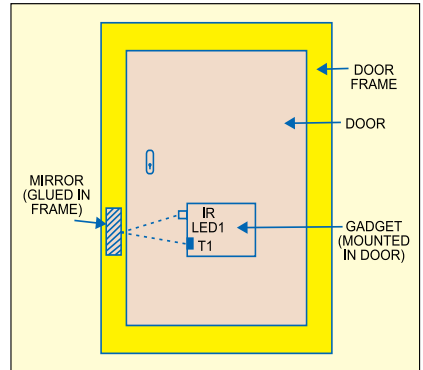

Fig. 3: Back view of the door assembly

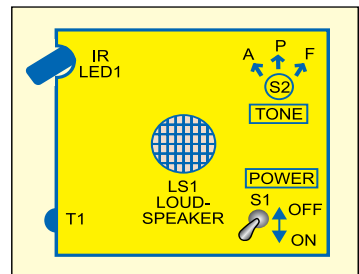

Fig. 4: Suggested enclosure with major components layout

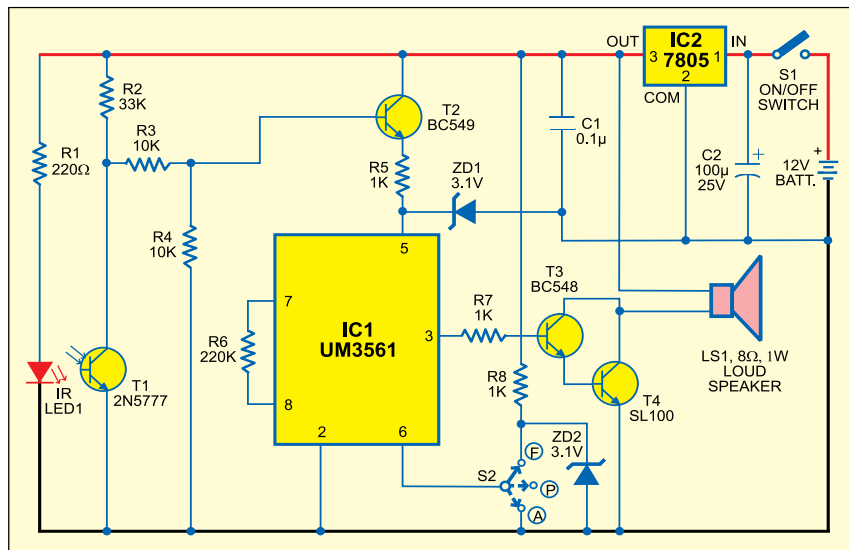

Fig. 1: Circuit of the door guard

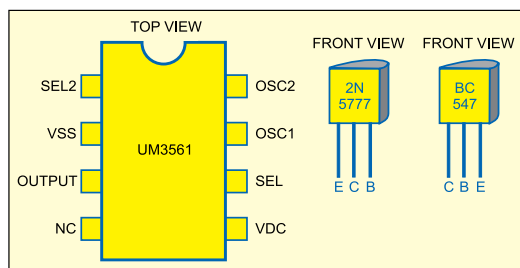

Fig. 2: Pin configurations of UM3561 and transistors 2N5777 and BC547

(T1). The IR beam falling on phototransistor T1 reverse biases npn transistor T2 and IC1 does not get positive supply at its pin 5. As a result, no tone is produced at its output pin 3 and the loudspeaker remains silent. Resistor R1 limits the operating current for the IR LED.

When the door is opened, the absence of IR rays at phototransistor T1 forward biases npn transistor T2, which provides positive supply to IC1. Now 3-siren sound generator IC UM3561 (IC1) gets power via resistor R5. The output of IC1 at pin 3 is amplified by Darlington-pair transistors T3 and T4 to produce the alert tone via the loudspeaker.

Rotary switch S2 is used to select the three preprogrammed tones of IC1. IC1 produces fire engine, police and ambulance siren sounds when its pin 6 is connected to point F, P or A, respectively. ●