

HOME SECURITY SYSTEM

Dave Goodman

- Six independent channels with two groups per channel
- Two or four wire operation with line sensing of open or short circuit or resistance change (jumping)
- Tamper-proof main cabinet
- External horn loop control has its own open/short circuit and jumping protection
- Presetable entry and exit delay timers

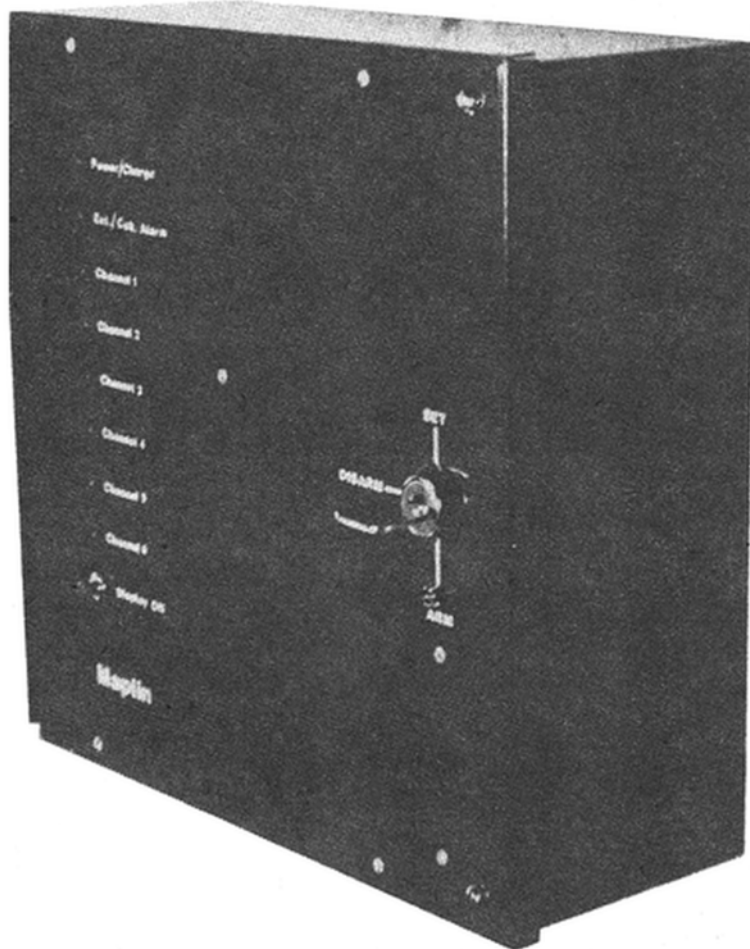

This new home security system offers a high degree of protection for domestic or commercial premises coupled with excellent long-term reliability. The unit is mains operated, but will run off its small internal nickel-cadmium rechargeable battery pack for 2 to 3 days depending on the size of the system. The internal battery is continuously charged when the mains is present and changeover from mains to battery and vice-versa has no effect on the system. CMOS circuitry is used throughout to minimise current drain.

There are sockets for six separate plug-in channels so that for example all downstairs windows could be connected to one input, all downstairs doors to another, all upstairs windows to another and perhaps shed and garage doors and windows to another. When setting the system you know immediately where to look for the window left open accidentally if the system will not set. Or parts of the system only may be set. For example, during the late evenings, the shed and garage circuit only could be set. Whatever your requirements this system offers the fullest possible flexibility for complete security.

The external horn is also fully protected when fitted with dry batteries. Its prominent position alone will deter most burglars, but any attempt to tamper with it will set it off. If the wires to it are cut or tampered with, the horn will sound. Even ripping the box off the wall will not stop the alarm. The recommended dry batteries will sound the alarm at full power for at least four hours even if the wires are cut.

The alarm is extremely easy to build, with internal wiring kept to an absolute minimum. Operation is by a single key-switch and exit and entry delays may be preset to suit your requirements. There is an LED for each channel, giving monitoring facilities and an internal sounder giving 'alarm condition' tones. Even the main cabinet is protected, by a micro-switch fitted to the PSU PCB.

Circuit Description Mains PCB

The key switch S9, which is shown in Figure 1 with its contacts made, controls the 'disarm' and 'set' conditions of the alarm unit. TR1 is conducting and thus inhibiting the exit delay timer oscillator IC1 c and d, and IC2, a 14 stage counter/divider, is held reset.

The oscillator IC1 c and d is frequency variable between 25 Hz (40 ms) and 10 kHz (100 us). This clock signal is divided down by IC2 by 8192 giving a minimum time out period of 0.8 seconds and a maximum period of 5.5 minutes. So allowing for variations in tolerances, IC1 c, d and IC2 function as an exit delay timer presetable by RV1 giving periods of between 0 and 6 minutes.

IC1 a, b and IC3 function as described above but are used as an entry delay timer, presetable by RV2.

In the disarm mode IC2 pin 3 is at 0V and D2 is conducting. Consequently exit delay tone modulator IC5 c and d is inhibited. IC10 a output is high, holding TR5 and LED 9 ('ARM' LED) off. Latch IC10 b and d output is high. Entry delay timer is held off via D4 and IC10 b output low. Counter IC3 pin 3 is low and alarm tone modulator IC5 a and b is inhibited via D7 conducting.

Latches IC7, 8 and 9 have normally high outputs connected to LED buffer IC11 preventing channel LEDs 3 to 8 from turning on. A positive trigger pulse greater than 25 ms in duration present at any of the inputs to the latches from switches S3 to 8 allows the channel LEDs to turn on for the duration of the triggering signal.

Switch S2 operates TR7 which discharges C13 and operates TR6, the LED display. TR6 remains on for the time constant set by R43 and C13, approximately 90 seconds.

Operating switch S9 (contacts open) in the 'set' mode turns TR1 off. This removes the inhibit on the exit delay oscillator IC1 c and d allowing it to run at the frequency determined by RV1. IC2 divides this signal and IC2 pin 3 goes high. While IC2 is counting, D2 is not conducting and IC5 c and d run at a frequency of approximately 8 Hz. The inhibit on the tone generator IC6 b and c is removed allowing it to run at approximately 3 kHz modulated at 8 Hz.

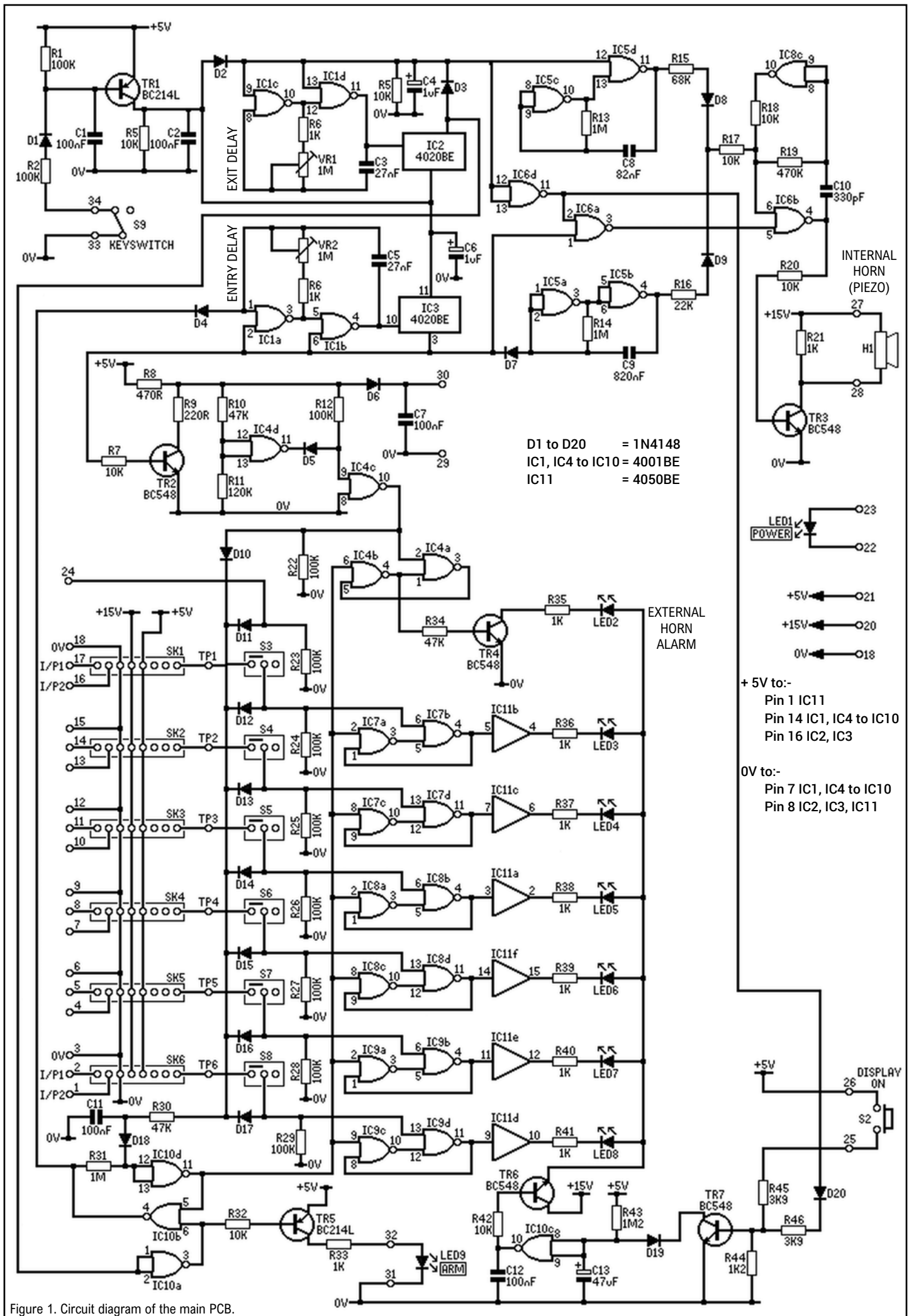

Figure 1. Circuit diagram of the main PCB.

At the end of the timing period, IC2 pin 3 goes high, inhibiting IC5 d and IC6 d. IC10 a goes low, TR5 conducts and the 'ARM' LED turns on. IC10 d inhibit is removed and a positive trigger pulse from switches S3 to 8 latches IC10 d low. The appropriate IC7, 8 or 9 goes low and latches, operating a channel LED.

This same trigger pulse also removes the inhibit on the entry delay oscillator IC1 a and b via IC10 b and d. Consequently it begins to run at the frequency set by RV2. IC3 divides the clock signal and when pin 3 goes high the oscillator stops running, TR2 conducts, latching IC4 a and b, and operating LED 2.

Alarm tone modulator IC5 a and b runs at 0 to 5 Hz and modulates the 3 kHz tone oscillator IC6b and c developing the alarm tone signal at H1.

Power Supply

The power supply is shown in Figure 2. T1, BR1 and C2 provide 15 volts to the LED arrays, speaker output stages and charging circuit. C1 is a 0.1µF interference suppressor, which removes transient spikes from the mains.

LED1, R3, R1, TR1 and D1 form a constant current source for charging the six 1.2 volt nickel cadmium batteries used for power failure standby. The alarm current requirement is very low so that fully charged batteries will provide enough power for a few days. The trickle charge is set by R1 to 4 mA and is temperature stabilised by LED1.

The supply voltage at pin 7 is approximately 15 volts and the battery supply is 7.5 volts. D2 will normally be reversed biased when mains voltage is applied and REG1 will deliver +5 volts at 100 mA. LED1 also serves as a mains pilot light.

Removing the mains supply extinguishes LED1, removes the charging current and forward biases D2. Pin 7 drops to +7.5 volts while pin 8 remains at +5 volts. C3 and 4 ensure that no spurious spikes are produced during changeover to battery standby. The batteries should be checked periodically. If standby power is not required, short circuit pins 4 and 5 together to light LED1.

Break Contact Module

The break contact module shown in Figure 3 works on a balanced line system. The line (contact) inputs, 1 and 2, are set for +2.5 volts measured on TPA and TPB and adjusted with RV1 and RV2.

Up to five switch contacts (and 22K resistors) are used on each input allowing ten contacts per module as shown on Figure 18. The number used is dependant on the system mode chosen.

IC1 has R3 connected between input and inverting output. The gate is therefore used in its linear region and the output (at the test points) will be balanced at half the supply.

A high or low voltage swing, at the inputs, is detected by IC1 a and d, and the

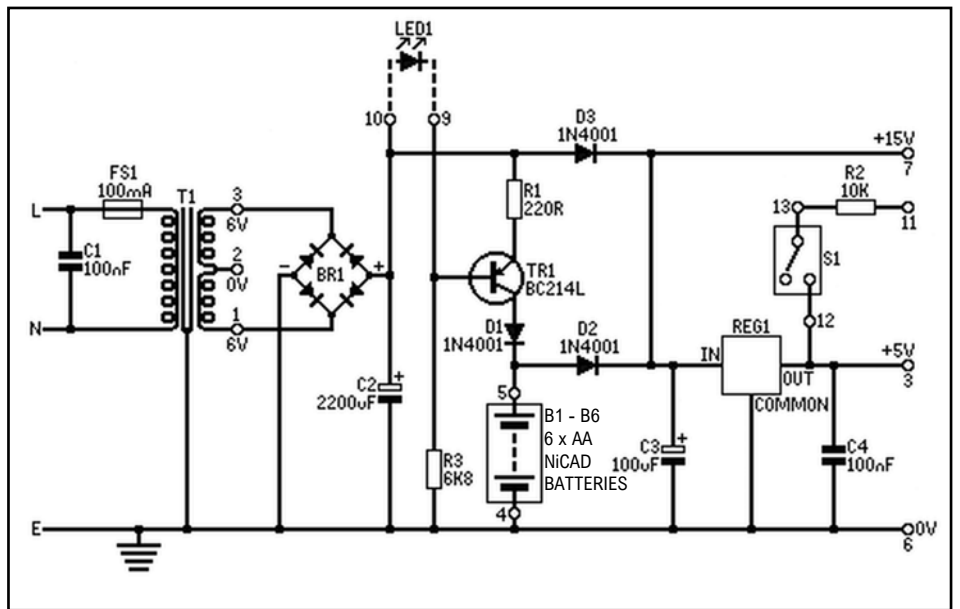

Figure 2. Circuit diagram of the power supply.

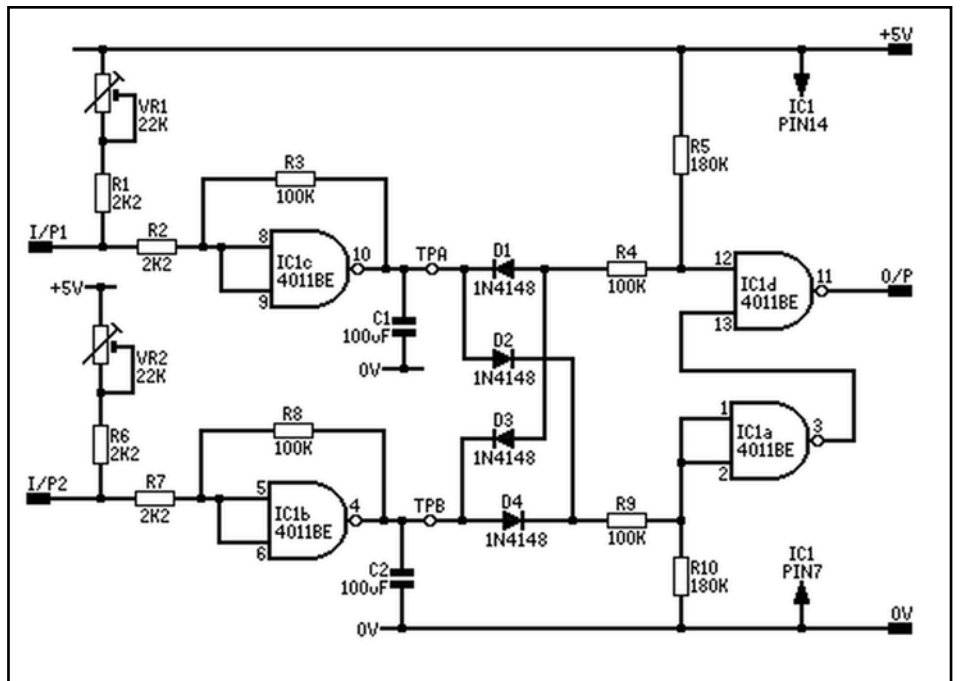

Figure 3. Circuit diagram of the Break Contact Module.

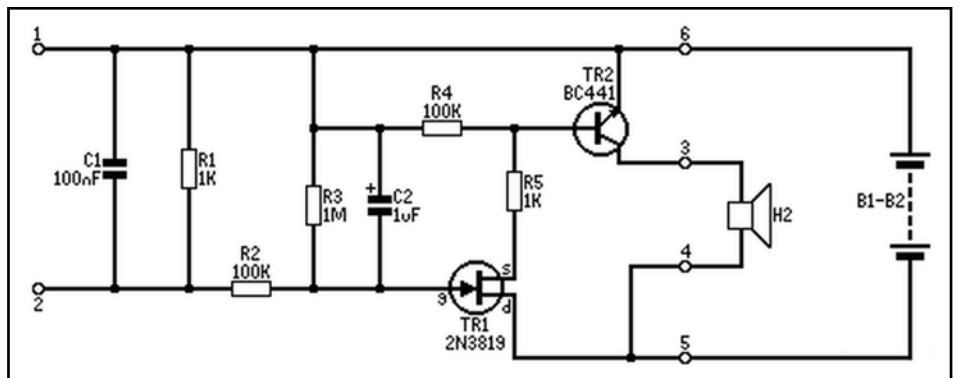

Figure 4. Circuit diagram of the External Horn PCB.

output, normally low, will pulse high for the duration of the input change.

External Horn

The external horn circuit is shown in Figure 4. R1 terminates the security loop connected from pins 1 and 2 to pins 30 and 29 on the main PCB. A current, set at 3 mA, is generated in the loop and cutting, short

circuiting or reversing, will bias TR1 into conduction. TR2 will switch on and the battery pack then supplies H2.

Returning the loop back to its normal condition would appear to bias TR1 off and prevent H2 from operating. This does not happen, owing to detection circuit IC4 c, d (Figure 1) R10, R11, R12 and D6 switching, and dropping the loop current down to 1

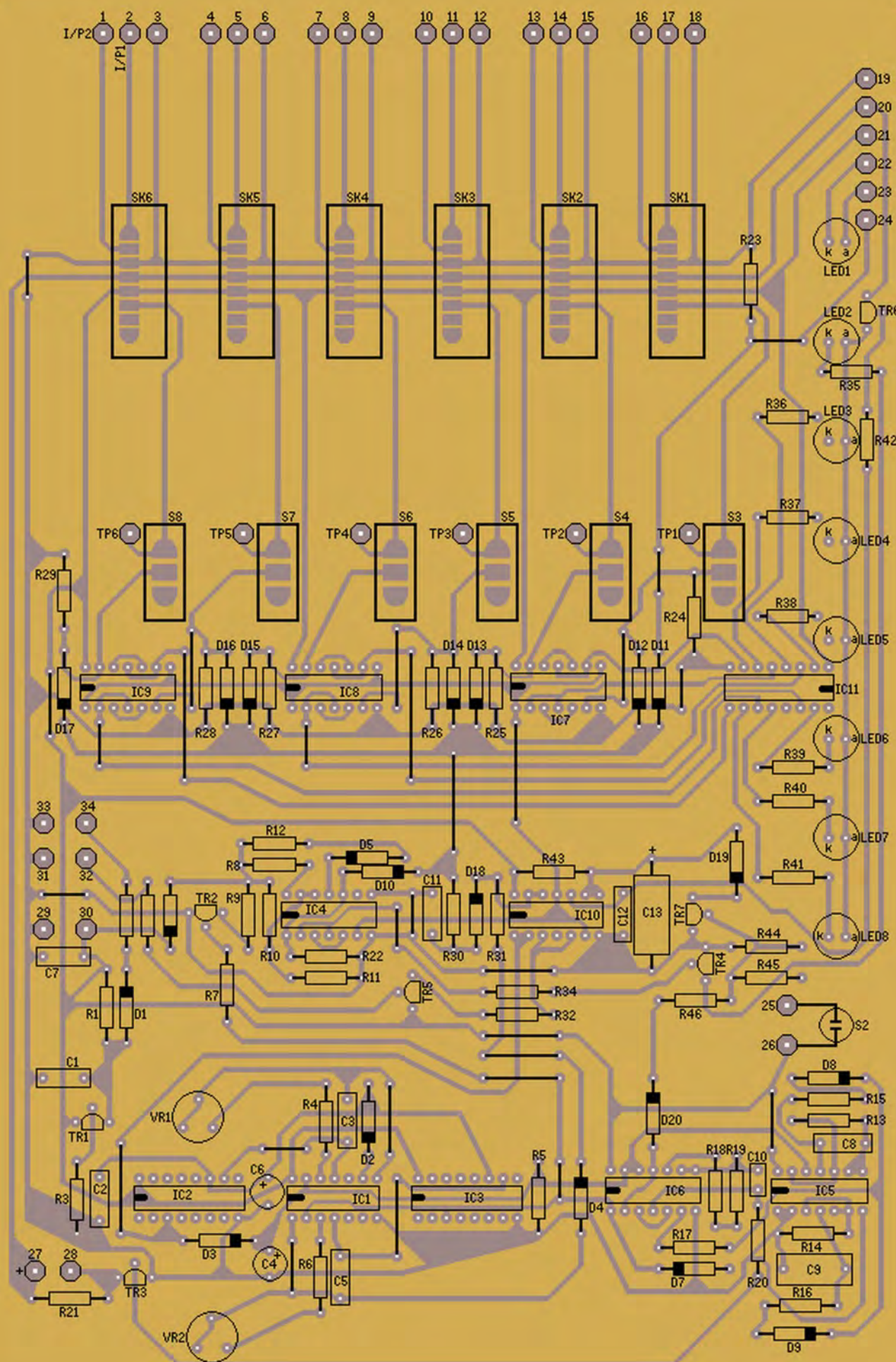
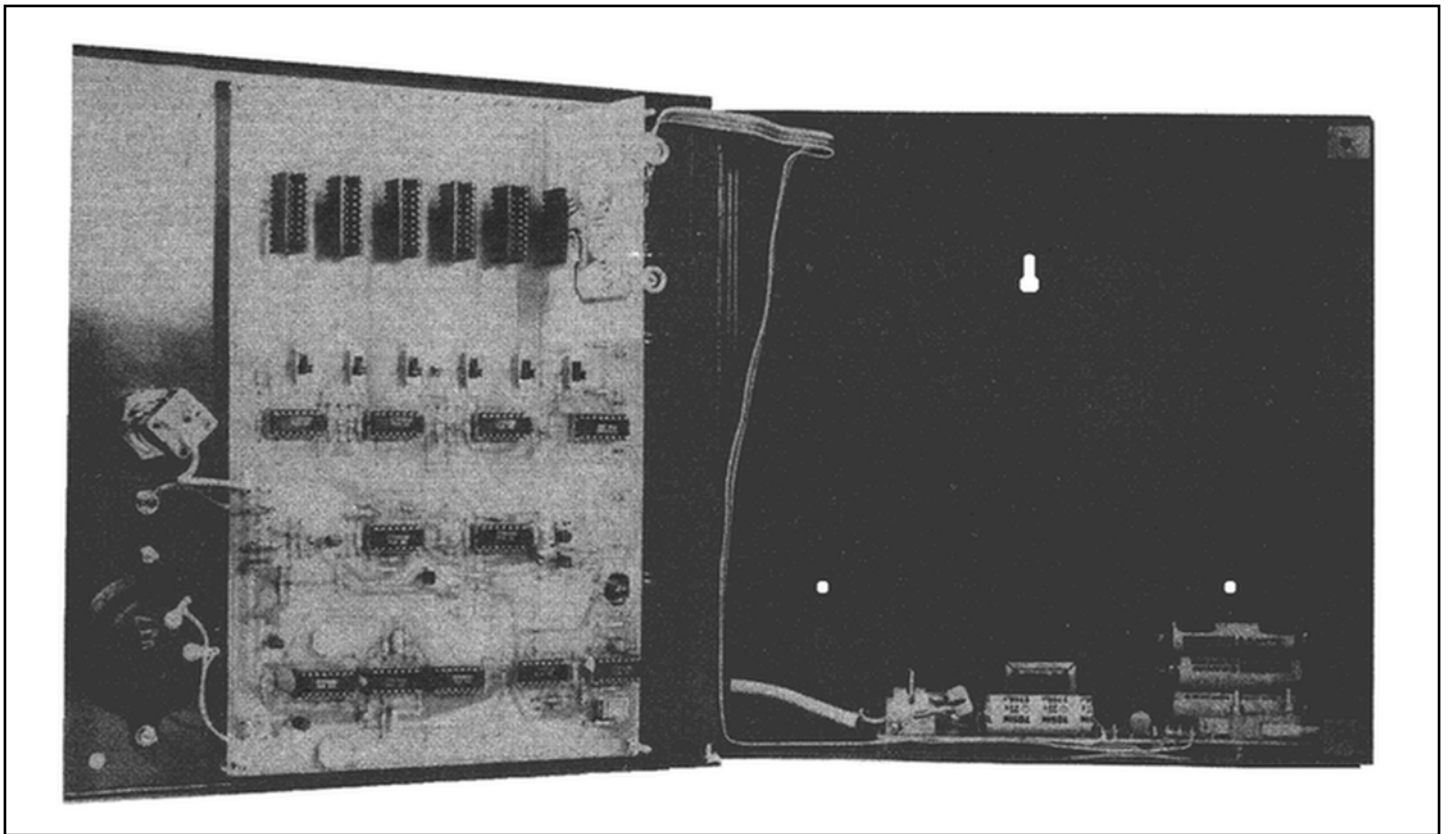

Figure 5. Component overlay of the main PCB.



Pic A. . Internal view of the control box with Main PCB fitted to the door and the PSU mounted in the base of the box.

mA. The horn will continue to sound until the main alarm key switch is turned off.

Please note that with internal batteries connected, the horn will sound immediately, until the security loop is connected. So when fitting the system, the loop must be wired to the main alarm first, and then connect the batteries (see Figure 9).

Construction

Assembly and Setting Up Main PCB

Refer to the parts list 1 and Figure 10. Use 24 swg enamelled copper wire to make the 28 link straps and fit these first. Next, fit the Veropins and the diodes. (The black tips are shown as white blocks on the legend.) Fit all resistors and capacitors. Note that electrolytic and tantalum types are polarised

and have a '+' sign which must be correctly orientated. Fit the two cermet presets RV1 and 2, and turn fully clockwise, to 0 on the legend. Connect a 1K test resistor RT across pins 29 and 30. (Note, this will be removed when using the external horn PCB, but must remain in place if the external PCB is not in use.)

Refer to Figures 11 and 13 when mounting the channel LEDs. LEDs 1 to 8 are mounted to the PCB from the track side. Figure 13 shows the lead designations. Place the correctly orientated LED into position and insert a spacing strip 8 mm x 1.5 mm (spare Veroboard etc) between the legs. Bend the legs under the PCB, to hold in position and solder one leg only. Repeat for all eight LEDs.

Figure 12 shows the mounting procedure for fitting the PCB to the inside cabinet lid. Place five 1 inch x 6BA CSK screws through the lid, tighten down with five 6BA nuts and washers. Place five 6BA x ¼ inch spacers over the screws and offer the PCB to the lid, positioning the channel LEDs in the holes provided. With LEDs correctly positioned, remove the PCB and solder the eight remaining LED legs. Re-check all component values and positions. Check for dry joints, solder splashes and short circuits on the track face. If all is in order, mount the PCB on to the lid and hold with five 6BA washers and nuts.

Push switch S2 mounts through the PCB and lid and is wired to adjacent pins 25 and 26. Mount LED 9 and connect to pins 31 and 26. Mount LED 9 and connect to pins 31 and

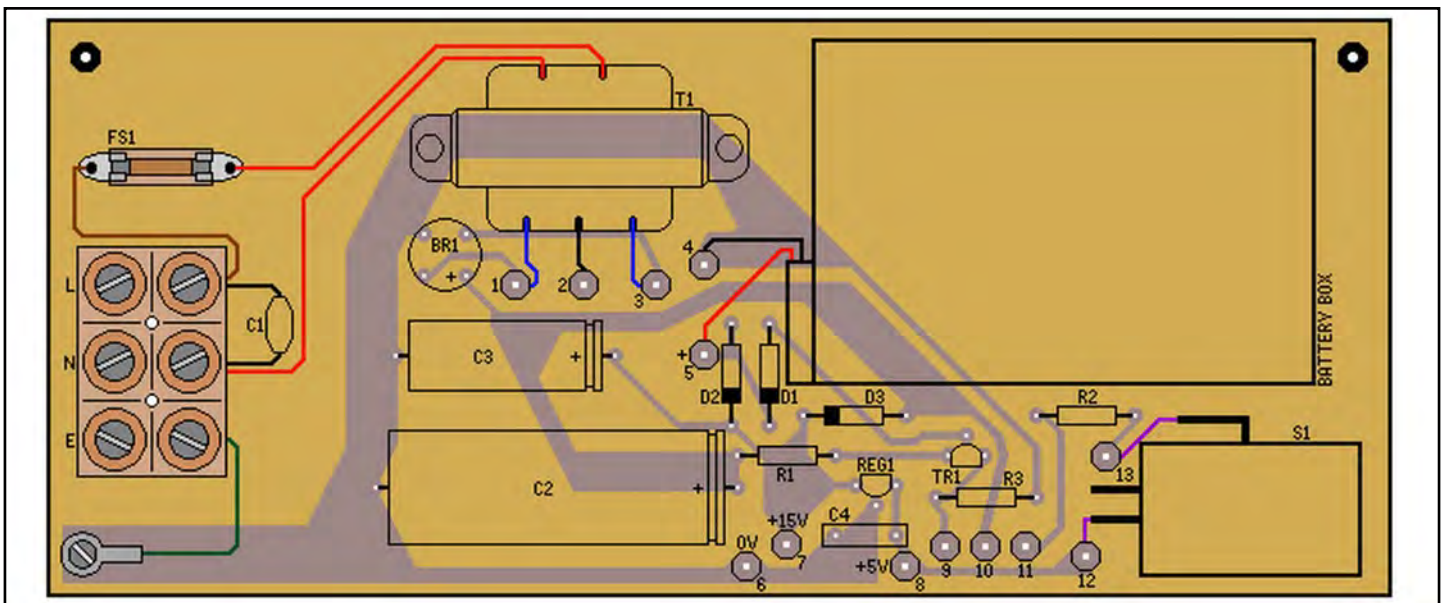

Figure 6. Component overlay of the PSU PCB.

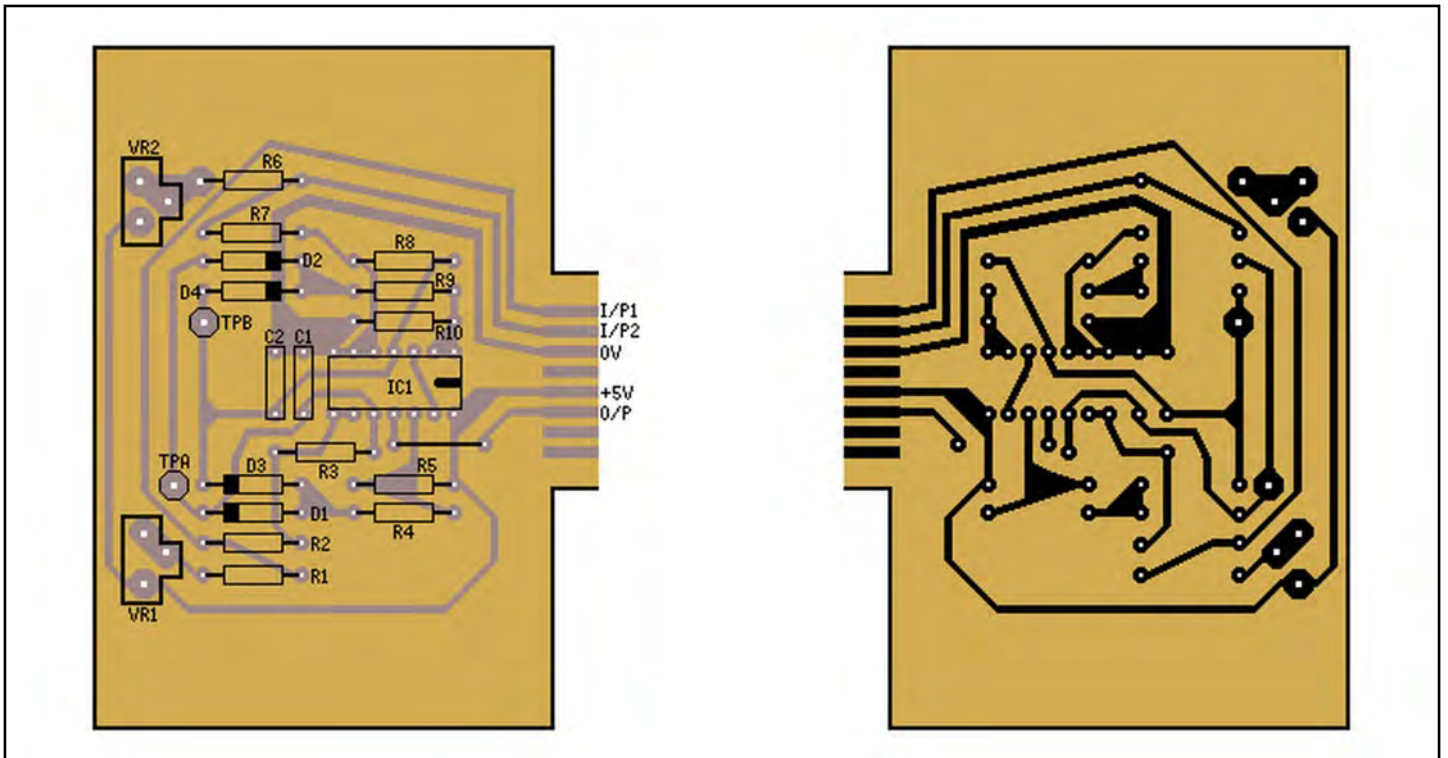

Figure 7. Track layout and component overlay of the Break Contact Module.

32 (Figure 10). Mount key switch S9 and the Piezo horn HI using two ¼ inch x 6BA CSK nuts, bolts, washers. Wire H1 to pins 27 and 28.

Power Supply Unit

Next refer to the parts list and Figure 12 and 13 for the PSU assembly. Mount the three resistors, three diodes, BR1, TR1, and REG 1. Ensure correct orientation of these components before soldering. Fit the 13 Veropins, C2 and C3 noting the polarity. Mount T1 with two 6BA ¼ inch bolts, nuts and washers. Mount FS1 using a ¼ inch x 6BA nut and bolt and a three-way terminal block, using two 1 inch x 6BA bolts, nuts and washers. Wire T1 to FS1 and the terminal block 'N'. Wire the opposite end of FS1 to terminal block 'L'. Place heat shrink sleeving over C1 leads, and fit to terminal block 'N' and 'L'. The battery clip (PP3) is

connected to pin 5 (+ve lead red) and pin 4 (-ve lead black). The T1 secondaries connect to adjacent pins 1, 2 and 3.

Insert three 6BA x ½ inch CSK screws through the cabinet base holes (Figure 15), at front left, rear left and rear right hand side. The two front right hand side holes are for mounting the micro switch. Insert two 1 inch x 6BA CSK screws and tighten all five with 6BA washers and nuts. Place the PSU PCB over the five screws and position the micro switch with the roller arm behind the angle bracket. Tighten down with two 6BA washers and nuts. Place a 6BA tag washer over the front left screw, and two 6BA washers over the remainder. Tighten down with three 6BA nuts. Connect a piece of wire from the 6BA (chassis earth) tag washer to terminal block 'E'. Wire the micro switch (S1) to adjacent pins 12 and 13.

Break Contact Module

Refer to the parts list and Figure 7 for the break contact PCB. The board is very simple to construct and requires no explanation. Once assembled, and checked, plug into any one of the six channel sockets on the main PCB. Ensure switches S3 to S8 are 'out' of circuit.

External Horn

Refer to the parts list and Figures 8, 9 and 17 for the external horn PCB and wiring. Again, the construction is simple. Note the orientation of the tantalum C2 and the FET TR1. The crinkly heatsinks fits over TR2. Do not connect to main PCB at this stage.

Testing

Place a 20 mm, 100 mA fuse into FS1 position. Connect a length of three-way mains cable to the PSU terminal block.

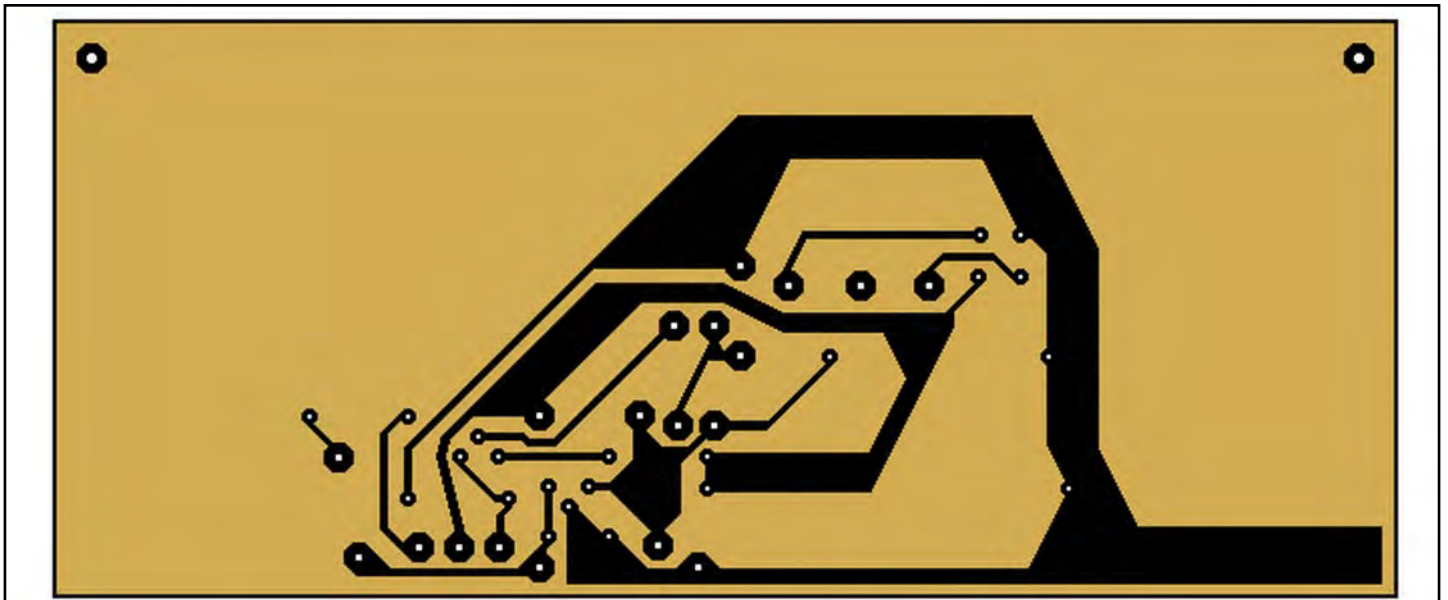

Figure 6(a). Track layout of the PSU PCB.

Ensure S1 is fully operated, and that no other wiring is connected to the PSU.

Place a voltmeter between 0 volt pin 6 and +15 volt pin 7. Apply mains power to the PSU, and check for a reading of 15 volts DC. Check for +5 volts between pin 6 (0 volt) and pin 8 and between 0 volt and pin 11 when S1 (micro switch) is released (slacken the 2BA bolt). Re-operate S1 and check for zero volts on the meter. Remove the mains supply.

Connect 22 inches of six-way ribbon cable between the PSU and main PCB as follows:

	PSU	To	Main PCB
(0V)	P6		P19
(+15)	P7		P20
(+5)	P8		P21
LED1	P9		P22
LED1	P10		P23
(S1)	P11		P24

Set the meter to 'amps' range and connect to pins 4 and 5 (or battery clip). Re-apply mains power and check for a reading of approximately 4 mA and ensure LED 1 lights up. Remove the meter and LED 1 should extinguish. If the standby batteries are to be used, connect the NiCad pack to the PP3 clip.

A voltmeter connected across pins 4 and 5 should indicate a reading of between 7.2 to 7.8 volts depending on the batteries state of charge. Note that LED 1 will stay on with the batteries part or fully charged, also an incorrectly placed battery, within the pack, will allow LED 1 to stay on, but the reading across pins 4 and 5 will be lower than +7 volts. (Rectify immediately as NiCad batteries do not like short circuits or reversed connections placed on them.)

For reliability, ensure that the battery pack is fully charged before use. The trickle charger keeps them topped up over a period of time and is not a fast charger.

Main PCB

With power on, and key-switch disarmed, LED 1 only should be on, and no alarm tones heard. Ensure RV1 and 2 are both fully clockwise, and turn key to 'set'. A high pitched tone will sound immediately lasting for no more than two seconds. When the tone stops, LED 9 ('ARM') comes on, showing that the alarm is now primed and ready. Note that the warble tone, sounds for the duration of the exit timer delay period and is pre-settable by adjusting RV1 anticlockwise. The PCB legend has scaled from 0 to 6 minutes and the small circle, on top of the cermet pot, acts as a pointer. If the exact time out periods are required, check the calibration scale with a watch or clock.

Once LED 9 has come on, further adjustment of RV1 will only be effective when the key is turned to 'disarm' and then back to 'set', starting the exit timer again.

Points

Connect a length of wire from P21 (+5 volt) to test point 1 (TP1). Operate S3 to the "IN" position. Press S2, display on and

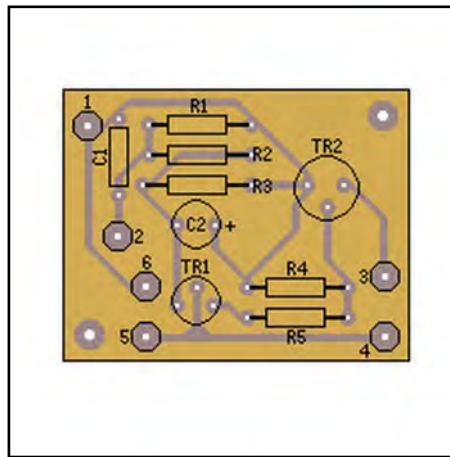

Figure 8. Track layout and component overlay of the External Horn PCB.

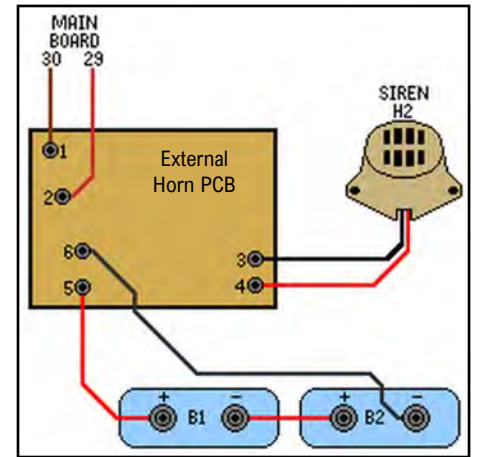

Figure 9. External Horn wiring diagram.

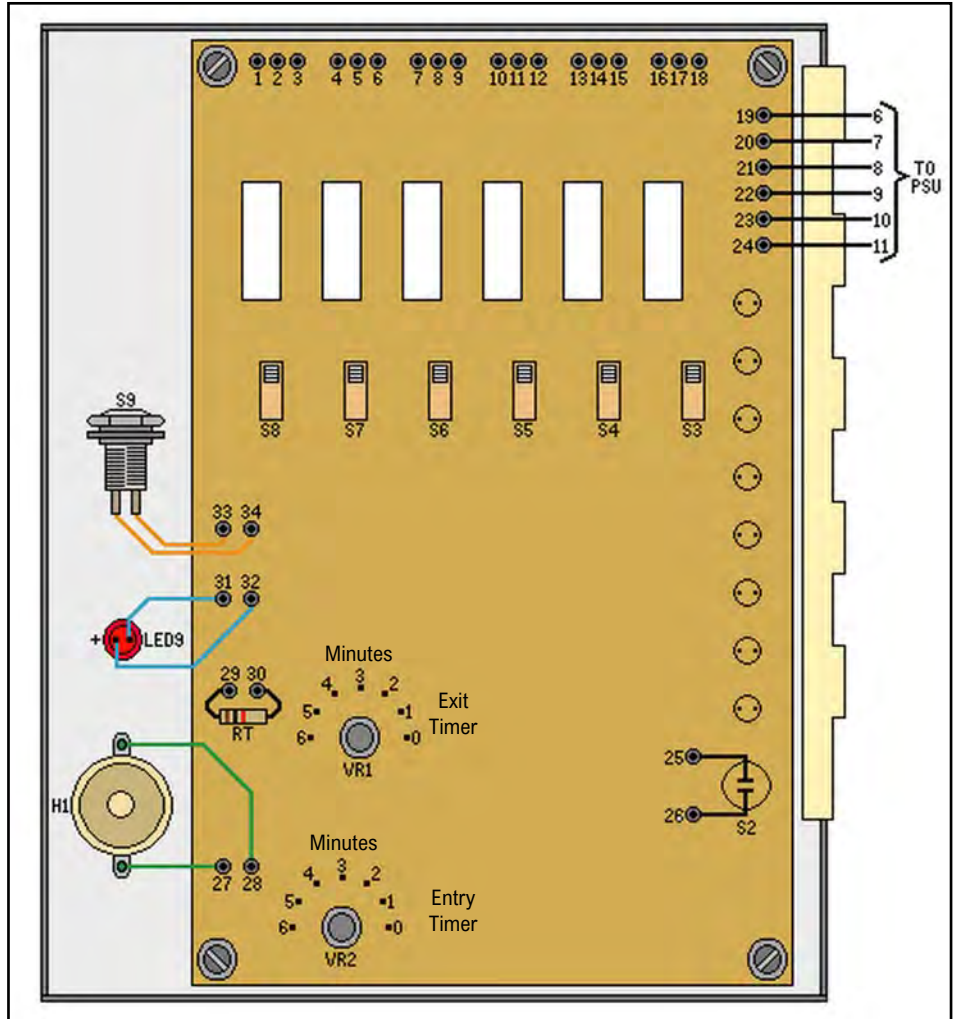

Figure 10. Main PCB wiring.

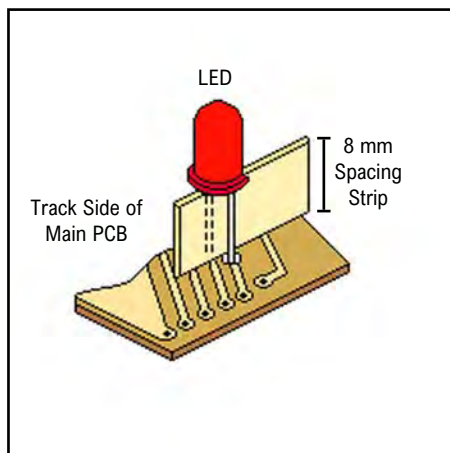

Figure 11. Indicator LED mounting.

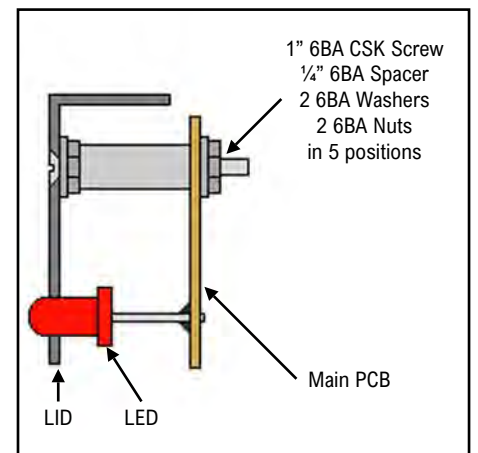

Figure 12. Mounting of Main PCB to cabinet door.

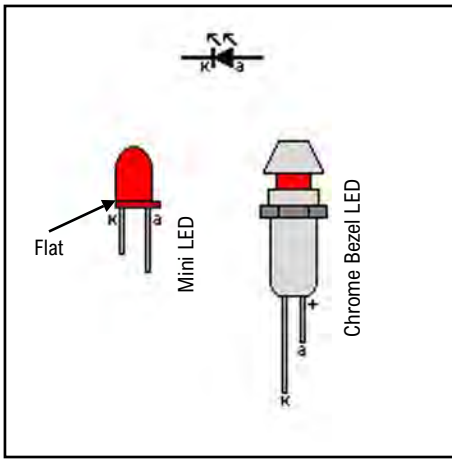

Figure 13. LED lead outs.

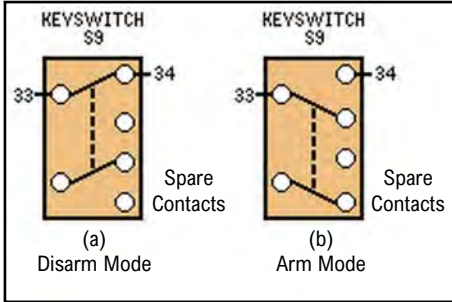

Figure 14. Key switch wiring.

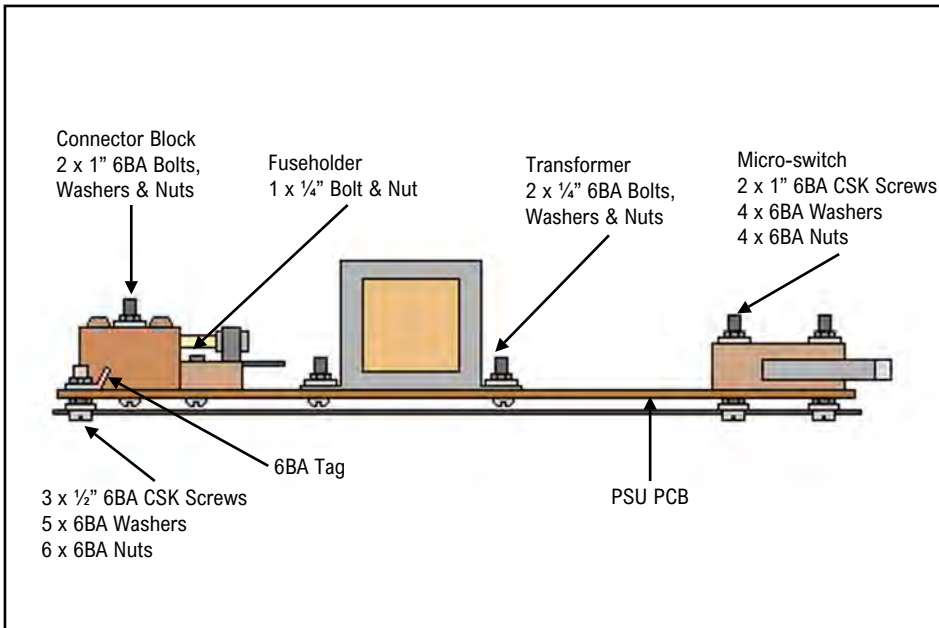

Figure 15. Mounting the PSU PCB and components.

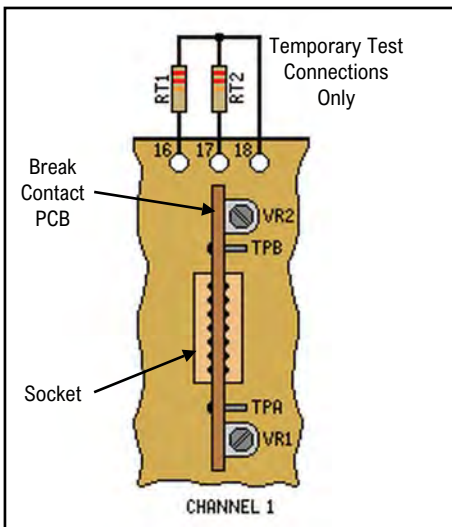

Figure 16. Testing the Break Contact Module.

release. Channel 1 LED 3 will come on. Place S3 to the "OUT" position. LED 3 will go out. Repeat the above tests from P21 (+5 volt) to TP2 to TP6 and S4 to S8 checking the channel LEDs 4 to 8. Note that pressing S2 allows the channel LEDs to light up, once triggered, for approximately 90 seconds. S2 will have to be re-operated for a continued display etc.

Remove the test lead from the test point, but leave attached to P21 (+5 volt). Turn the key switch to "set". Once the "armed" LED has come on, place switches S3 to S8 to the "IN" position (note - remove any plug-in PCBs). Check that no tone is heard and that LEDs 1 and 9 only are on. Touch the +5 volt test lead to test points 1 to 6 in turn, all channel LEDs should come on, followed by a slow, two-tone alarm signal. Ext/Cab alarm, LED 2, will come on, indicating that the external horn trigger circuit has been operated. This alarm tone continues until the key switch is set to "disarm". Leave the alarm sounding and check that after 90 seconds the display goes off (preserving batteries on standby). The alarm tone should still continue. Press S2, check original display is returned.

Ext. Alarm

Place a short circuit across test resistor RT (1K) between pins 29 and 30. Press S2, LED 2 will light, indicating that the external loop sensing circuit has been tampered with. Remove the short circuit; LED 2 will go out. Remove one end of resistor RT and press S2. LED 2 will, again, come on. Re-connect RT and LED 2 should go out.

Turn the key switch to "set" and replace the short circuit across resistor RT. When the alarm sounds, remove the short circuit. LED 2 will stay on and the alarm will continue to sound. Return key switch to "disarm".

Power Failure

Note that if standby batteries are fitted and mains power is removed, LED 1 will go out. If the alarm unit is set and armed prior to removal of mains power, the system will stay armed, unless triggered appropriately. When running on standby power, the alarm tones will be slightly quieter than normal.

Entry Timer

Set RV2, entry delay timer, for the required time out period. Turn the key switch to "set" and trigger any channel (+5 volt to a test point). The selected channel LED should come on and stay on. The alarm tone will not be present until the time out period has been reached, then the alarm tone will sound and LED 2 will light. Reset the key switch.

Break Contact PCB

This module may be plugged into any of the sockets in channels 1 to 6 on the main PCB. Note correct orientation of the module, when fitting; the component side is to the right and the track side, to the left.

Remove all power to the system, turn the key switch to "disarm" and S3 to S8 to the "OUT" position. Connect two test resistors, RT1 and RT2 (22K) between pins 17 and 18 and pins 16 and 18, as shown in Figure 16. These resistors are used for test purposes only and will be removed when the circuit is to be used.

Connect a voltmeter between TPA, on the module, and a convenient zero volt point, with the +ve lead to TPA. Apply power to the system, and adjust VR1 for a reading of half the supply rail, i.e. +2.5 volts.

Repeat the test on TPB using VR2, and remove meter. Re-connect the meter between zero volt and TP1 to 6 (main PCB) depending on channel chosen for setting up the module, and check for zero volts. Short circuit resistor RT1, and check for +5 volts on the appropriate test point (main PCB). Remove the short circuit and repeat the test for RT2. Set the chosen channel switch (S3 to S8) to the "IN" position. Turn the key switch to "set" and remove one end of RT1. The appropriate channel LED will come on etc. Re-connect RT1; reset the key switch and repeat the test for RT2.

Reset the key switch and remove test resistors RT1 and 2.

Circuit Monitor

Turn the key switch to "disarm". The tone and all displays will be cancelled. Note that in the disarm mode and with S2 pressed, the unit gives a useful monitor facility of doors, windows etc, which can be checked before arming the system. Loosen the 2BA bolt holding off micro switch S1. Ensure the roller-arm releases, and turn the key switch to "set". After the time out period and LED 9 has come on, the Ext/Cab alarm LED 2 will light, showing that the cabinet has been tampered with, and the alarm tone will sound. Reset the key switch to "disarm". The alarm tone will cancel, but LED 2 will remain on for 90 seconds; display timeout. Re-operate S1 by tightening the 2BA bolt and LED 2 will go out.

External Horn PCB

Figures 8 and 9 show the connections for using an external horn. For test purposes remove all power from the system (disconnect all batteries) and wire the PCB to pins 29 and 30 (remove resistor RT). Any changes made to these connections will trigger the alarm so ensure correct wiring. Connect the electronic siren to pins 3 and 4; the black lead is negative and the red +ve. Since the siren is inside a box, its own cover is not required and should be removed to assist wiring and make the sound output as great as possible. Connect batteries B1 and B2 to pin 5 (+ve) and 6 (-ve). The battery supply should be 12 volts and various types of dry cell (6 volts each) are available. Note that no charging current is available to these batteries.

The horn (H2) will sound immediately, so return power to the alarm unit as soon as possible. Place a short circuit across pins 29 and 30 (main PCB); H2 will sound. Remove the short circuit and H2 will cease.

Turn the key switch to "set" and repeat the test. Both internal and external horns will sound along with LED 2. Turn the key

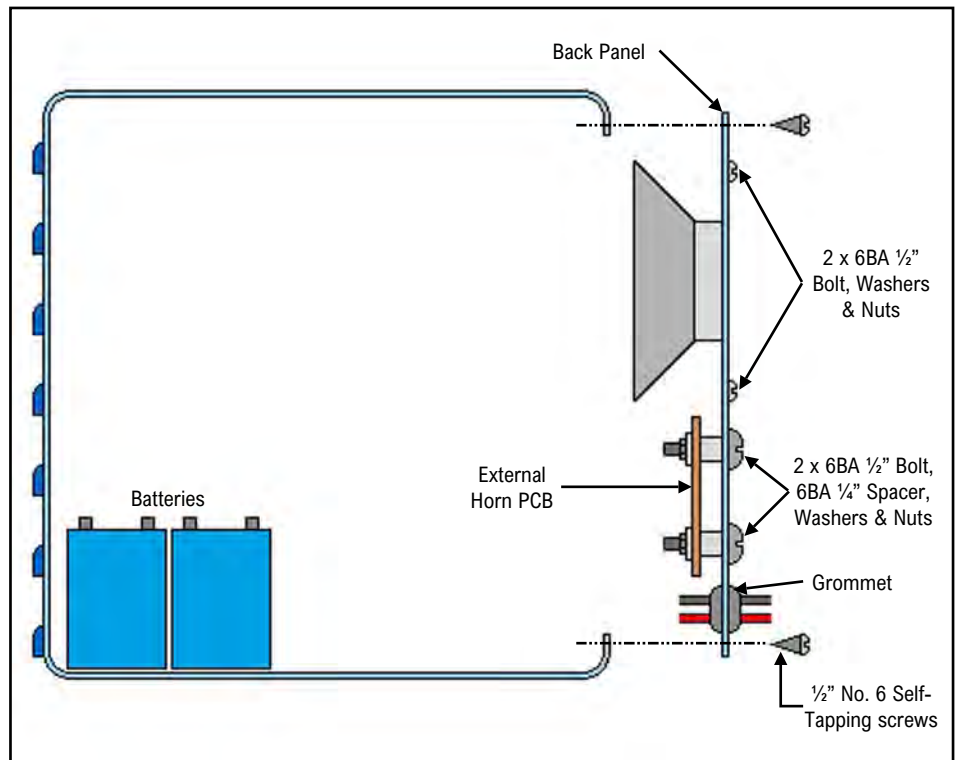

Figure 17. Assembly of the External Horn Box.

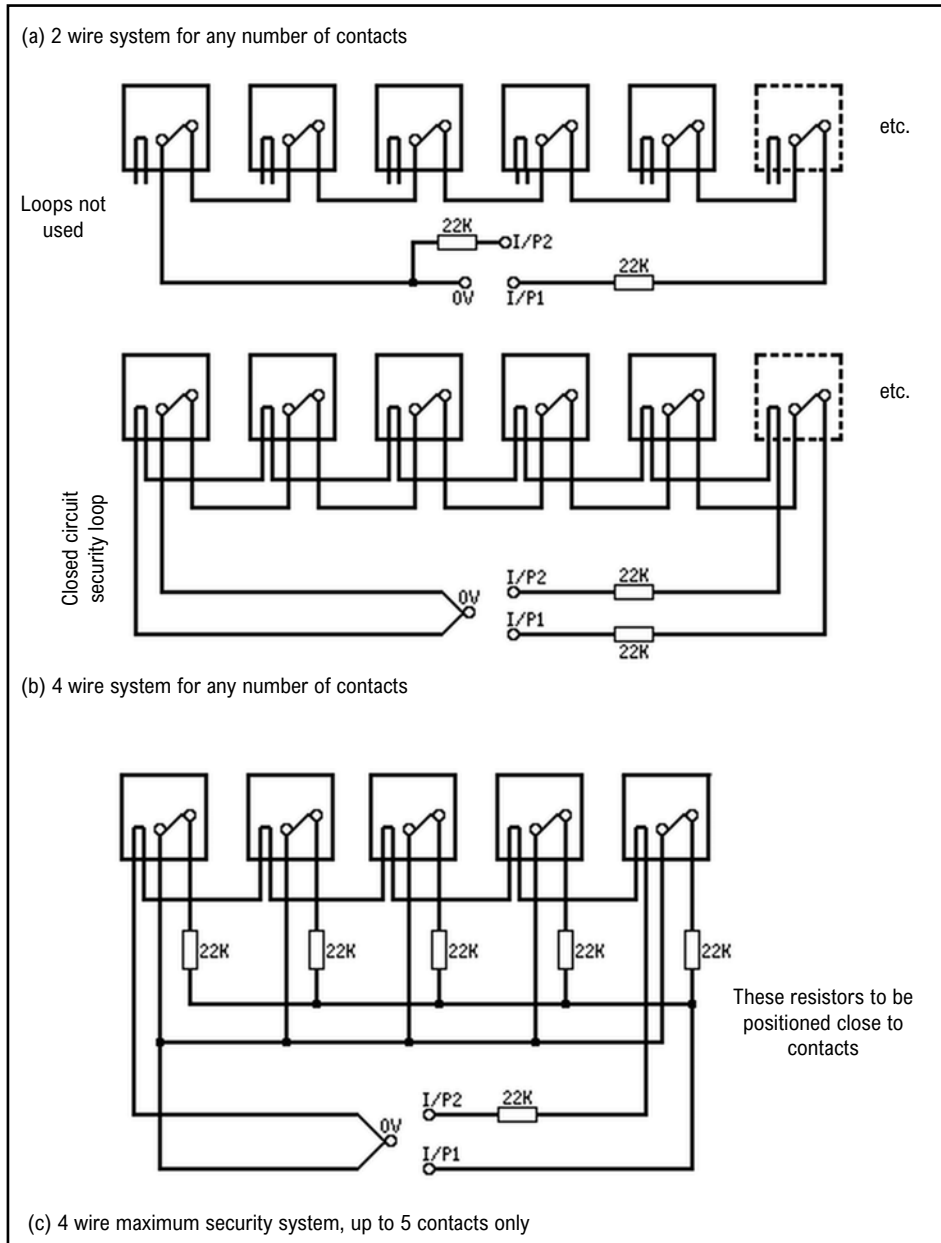

Figure 18. Methods of wiring alarm contacts.

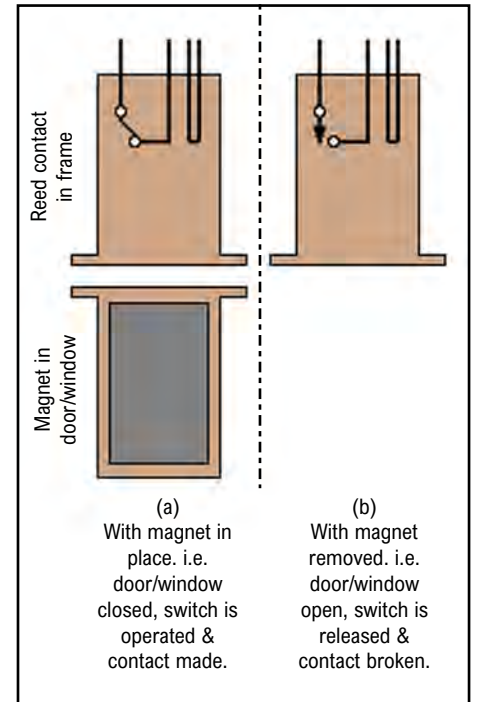

Figure 19. Reed switch connections.

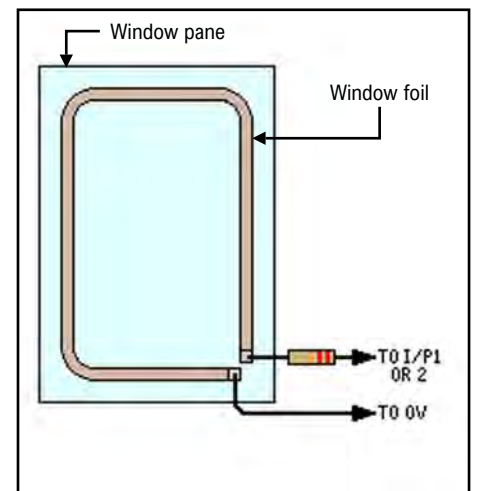

Figure 20. Window foil connections.

switch to "disarm" and both horns should stop sounding. Note that the 12 volt external batteries supply the horn only, via TR2. When not in use, the current drain from B1 and B2 is approximately 5µA and will not effect the shelf life of the batteries greatly.

Using The System

Various systems for sensing and triggering the alarm unit are available and are listed in the parts list. Typical connections are shown in Figures 18,19 and 20. Note that for maximum security only five switches, each with a 22K resistor, should be used per input (10 switches per module) and connected as in Figure 18(c). With 6

modules in use, up to 60 switches can be accommodated, using a two wire system, or 30 switches using the 4 wire system. Whatever method is favoured, refer to the break contact setting up procedure and adjust RV1 and RV2 on each module for half the supply voltage. Any form of shorting, bridging, reversing or cutting connections will trigger the alarm.

If one input only, per module, is to be used, terminate the remaining input with a 22K resistor (see Figure 16) otherwise the alarm will keep sounding, with that channel switched in. Magnetic reed switches can be mounted into door frames and the magnet into the door directly opposite. Surface type

reeds are available for metal frame works. Pressure mats should be placed under carpets etc ensuring adequate clearance from furniture and metal foil strip can be fitted to glass panels. There will shortly be ultra sonic and micro-wave doppler detectors available and those will interface directly to the break contact module.

Finally, remember that setting the modules to half (+2.5 volt) supply rail will allow detection of short circuits or open circuits, within the contact loop so make or break contacts may be accommodated, using suitably placed 22K resistors.

BURGLAR ALARM MAIN PARTS LIST				BURGLAR ALARM EXTERNAL HORN PARTS LIST			
Resistors - All ¼ watt 5% Metal Film				Resistors - All ¼ watt 5% Metal Film			
R1, R2, R12, R22 to R29	100K	Brown Black Yellow	11	R1, R5	1K	Brown Black Red	2
R3, R5, R7, R17, R18, R20				R2, R4	100K	Brown Black Yellow	2
R32, R42	10K	Brown Black Orange	8	R3	1M	Brown Black Green	1
R4, R6, R21, R33, R35 to R41	1K	Brown Black Red	11	Capacitors			
R8	470R	Yellow Violet Brown	1	C1	100nF disc ceramic		1
R9	220R	Red Red Brown	1	C3, C5	27nF Polycarbonate		2
R11	120K	Brown Red Yellow	1	C4, C6	1µF 35V tantalum		2
R13, R14, R31	1M	Brown Black Green	3	C8	82nF Polycarbonate		1
R15	68K	Blue Grey Orange	1	C9	820nF Polycarbonate		1
R16	22K	Red Red Orange	1	C10	330pF ceramic		1
R19, R30	470K	Yellow Violet Yellow	2	C13	47µF 10V axial electrolytic		1
R10, R34	47K	Yellow Violet Orange	2	Semiconductors			
R43	1M2	Brown Red Green	1	D1 to D20	1N4148		20
R44	1K2	Brown Red Red	1	TR1, TR5	BC214L		2
R45, R46	3K9	Orange White Red	2	TR2, TR3, TR4, TR6, TR7	BC548		5
RT (Test Resistor)	1K	Brown Black Red	1	IC1, IC4 to IC10	4001BE		8
VR1, VR2	1M	Cermet	2	IC2, IC3	4020BE		2
				IC11	4050BE		1
Capacitors				Capacitors			
C1, C2, C7, C11, C12	100nF disc ceramic		5	C1	100nF disc ceramic		1
C3, C5	27nF Polycarbonate		2	C2	1µF 25V tantalum		1
C4, C6	1µF 35V tantalum		2	Semiconductors			
C8	82nF Polycarbonate		1	TR1	2N3819		1
C9	820nF Polycarbonate		1	TR2	BC441		1
C10	330pF ceramic		1	Miscellaneous			
C13	47µF 10V axial electrolytic		1	H2	Electronic Siren		1
Semiconductors				Miscellaneous			
D1 to D20	1N4148		20	B1, B2	6 volt Lantern Battery		2
TR1, TR5	BC214L		2		Heatsink 5F		1
TR2, TR3, TR4, TR6, TR7	BC548		5		Single-sided terminal pins		6
IC1, IC4 to IC10	4001BE		8		Small grommet		1
IC2, IC3	4020BE		2		Self-tapping screws No. 6 ½ inch		10
IC11	4050BE		1		6BA ½ inch bolt		4
Miscellaneous					6BA washer		4
LED 1 to LED 8	Mini LED red		8		6BA nuts		4
LED 9	Chrome LED small		1		6BA x ¼ inch spacer		2
S2	High quality push switch		1	BURGLAR ALARM BREAK CONTACT MODULE PARTS LIST			
S3 to S8	Slide switch		6	Resistors - All ¼ watt 5% Metal Film			
S9	Key switch		1	R1, R2, R6, R7	2K2	Red Red Red	4
H1	Piezo horn		1	R3, R4, R8, R9	100K	Brown Black Yellow	4
SK1 to SK6	8-way edge connector		6	R5, R10	180K	Brown Grey Yellow	2
	6BA 1 inch CSK screw		5	RT1, RT2 (Test Resistors)	22K	Red Red Orange	2
	6BA ½ inch CSK screw		2	VR1, VR2	22K	Vertical sub-min preset	2
	2BA 1 inch bolt		2	Capacitors			
	6BA washer		12	C1, C2	100nF disc ceramic		2
	6BA nut		12	Semiconductors			
	6BA x ¼ inch spacer		5	D1, D2, D3, D4	1N4148		1
	Small grommet		2	IC1	4011BE		1
	Single-sided terminal pins		40	Miscellaneous			
	10-way ribbon cable			TPA, TPB	Single-sided terminal pins		2
	1M				DIL socket 14 pin		1
	DIL socket 14 pin		8				
	DIL socket 16 pin		3				
BURGLAR ALARM PSU PARTS LIST				BURGLAR ALARM BREAK CONTACT MODULE PARTS LIST			
Resistors - All ¼ watt 5% Metal Film				Resistors - All ¼ watt 5% Metal Film			
R1	220R	Red Red Brown	1	R1, R2, R6, R7	2K2	Red Red Red	4
R2	10K	Brown Black Orange	1	R3, R4, R8, R9	100K	Brown Black Yellow	4
R3	6K8	Blue Grey Red	1	R5, R10	180K	Brown Grey Yellow	2
Capacitors				Capacitors			
C1	100nF suppression capacitor		1	RT1, RT2 (Test Resistors)	22K	Red Red Orange	2
C2	2200µF 25V axial electrolytic		1	VR1, VR2	22K	Vertical sub-min preset	2
C3	100µF 25V axial electrolytic		1	Capacitors			
				C1, C2	100nF disc ceramic		2
				Semiconductors			
				D1, D2, D3, D4	1N4148		1
				IC1	4011BE		1
				Miscellaneous			
				TPA, TPB	Single-sided terminal pins		2
					DIL socket 14 pin		1