

Fig. 3. External appearance of Heathkit W-6M-70-watt amplifier.

plugged in. There are still plenty of people—this observer is one—who enjoy building something, particularly when in doing so we can save quite a bit of money—basically that representing factory labor and its associated overhead and profit. Heath equipment has long been noted for its reliability, and in the new W-6M 70-watt amplifier the results are all that could be desired, and at a price that betokens a considerable saving.

This amplifier, shown in Fig. 3, measures 14½ inches wide, 12½ inches deep, and 9½ inches in height, and has a shipping weight of 59 pounds. Most of this weight is, as would be expected, in the two transformers, so it is obvious that there is no skimping on quality. The circuit, which is shown in Fig. 4, offers some innovations which result in a high degree of performance. The first two stages consist of the two halves of a 12AU7, direct coupled.

The second half is the usual split-load (cathodyne) phase splitter, and it feeds a 12AX7 voltage amplifier, which in turn feeds a 12BH7 which is a cathode-follower driver for the two 6550 output tubes in an ultra-linear circuit.

The power supply uses a voltage doubler circuit with four silicon rectifiers and more than adequate filtering. An extra winding on the power transformer provides 130 volts to a selenium rectifier for bias supply. Plate currents in the output stage tubes are metered, and provision is made for balancing the two tubes by varying the bias on the driver tubes. Conventional output impedances of 4, 8, and 16 ohms are available for loudspeaker loads, and an additional 70-volt output tap is provided for feeding large speaker distribution systems. When driving loudspeaker loads, the damping is adjustable over a range from 0.5 to 10 by means of a continuously variable control.

Performance

Frequency response is within ± 0.5 db from 6 to 70,000 cps, with smooth rolloff beyond these limits to ensure transient stability. Power output is down 3 db at about 13 cps, while harmonic distortion remains below 0.25 per cent over the important ranges, and only reaches 1 per cent at 70 watts at frequencies of 20 and 10,000 cps. Intermodulation distortion reaches 1 per cent at about 73 watts, and at our rating point—2 per cent IM—the output was measured at 81 watts. Full output is reached with an input of 1.1 volts, and hum and noise measures lower than 70 db below 1 watt.

One of the problems encountered with the Williamson-type circuit—comprising the direct-coupled input pair of stages—was its poor performance as regards overload recovery. This was shown by oscillograph traces of signal output when the level was changed quickly from a high value to a very low value—a condition that is common in musical program material. No such instability was observed with the W-6M, however, and only the slightest amount of ringing was noticed on 10,000-cps square waves when driving a loudspeaker load, and none at all on frequencies below 2000 cps.

Variable Damping

The schematic of Fig. 4 shows an unusual arrangement of the output wiring. Note that the variable-damping-factor control is a dual potentiometer, with the 10-ohm section in the return side of the output winding. In order to maintain constant gain as the damping factor control is rotated, three different resistors are used for the three low-impedance output taps. Thus the control—which changes the ratio of voltage feedback to current feedback—can be calibrated directly in damping factor, and gain and distortion remain constant for any setting of the control.

With a high-quality speaker system there is little difference in performance as the

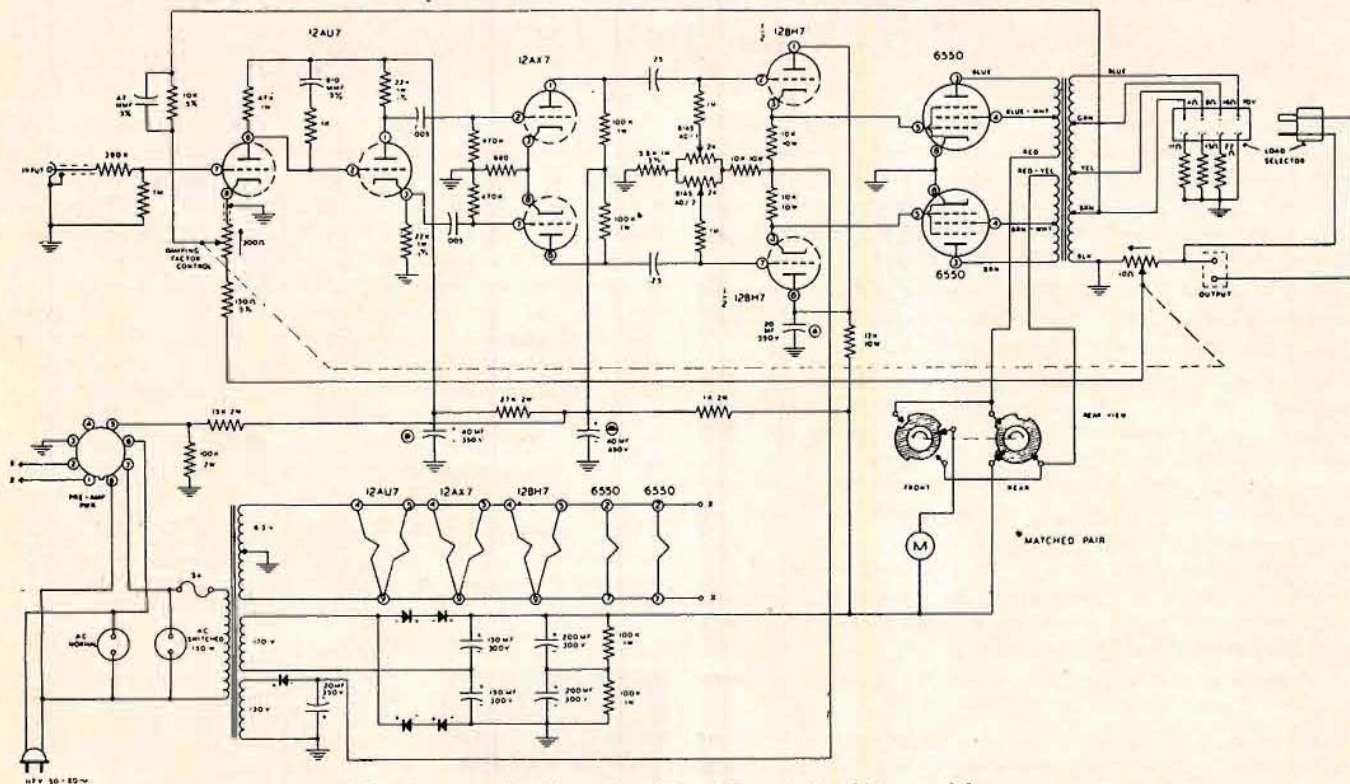

Fig. 4. Over-all schematic of the 70-watt Heathkit amplifier.