

Magnavox

SERVICE MANUAL

THE MAGNAVOX COMPANY • SERVICE DEPARTMENT
FORT WAYNE, INDIANA

Manual No. 6505

File: Volume 12
Miscellaneous Section
First Issue: November, 1976

BG7516 ODYSSEY

Scanned by Sly DC (2018)

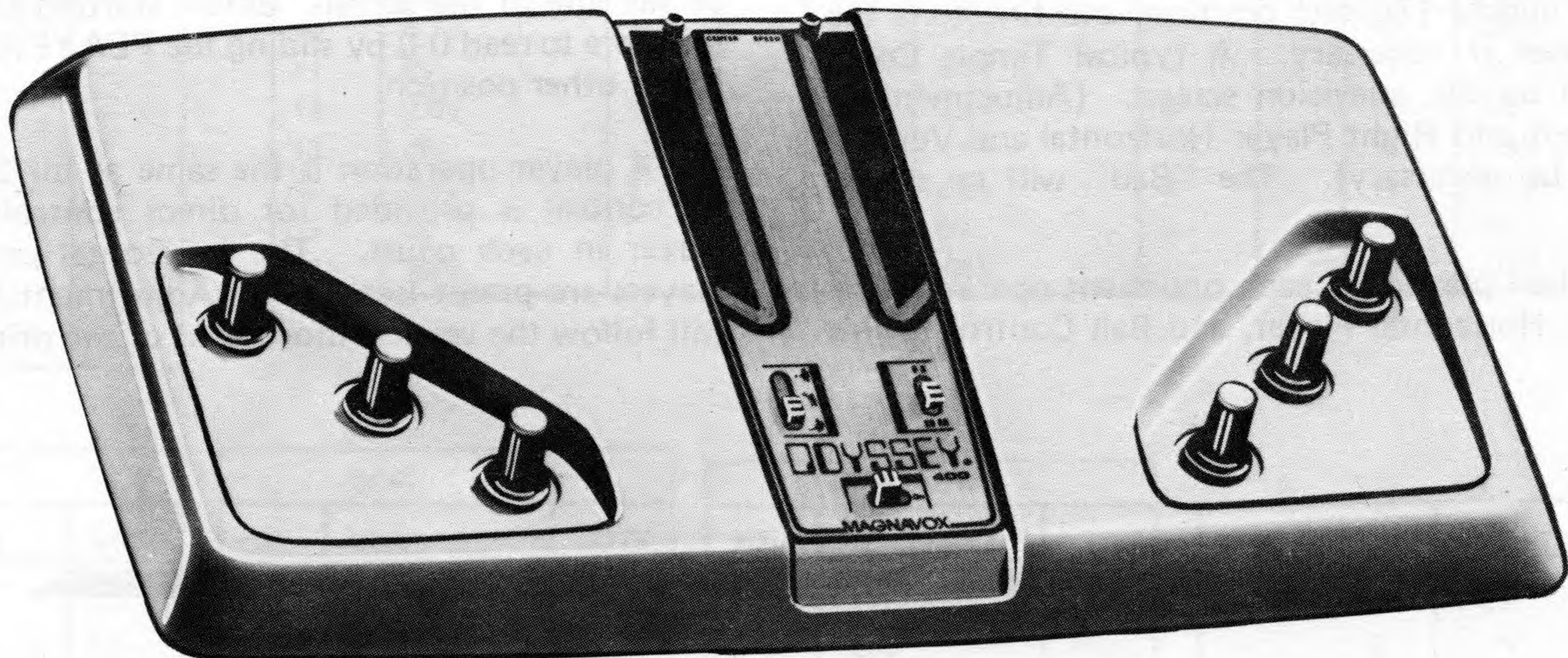

GENERAL INFORMATION

The BG7516 can be powered by either 6 "C" cells or an optional AC to DC 9 volt adapter.

The BG7516 has three games, Hockey, Tennis, and Smash,

and as a test of your skill incorporates variable "Ball" (English), Speed Control, and the option of two or four players with Tennis and Hockey. Also incorporated is digital On-Screen scoring.

SPECIFICATIONS

	<u>Minimum</u>	<u>Normal</u>	<u>Maximum</u>
Regulated Voltage Supply Measured at Pin 3 of IC1	4.5V	5.0V	5.5V
Current Drain BG7516	-----	65Ma	-----
Vertical Sync Frequency	59 Hz	60 Hz	61 Hz
Pulse Amplitude	2.8V	4.0V	-----
Pulse Width	300 usec	317.5 usec	340 usec
Horizontal Sync Frequency	15.704 KHz	15.734 KHz	15.784 KHz
Pulse Amplitude	3.5V	4.0V	-----
Pulse Width	4.0 usec	-----	8.0 usec
RF Carrier Frequency Channel 3	61.22 MHz	61.25 MHz	61.28 MHz
Channel 4	67.22 MHz	67.25 MHz	67.28 MHz
RF Output Into 300 ohms	1100 uV	-----	1600 uV

TYPICAL OPERATION (TENNIS)

Connect the 300 ohm twin lead from the Antenna/Game Switch to the 300 ohm antenna terminals of a properly adjusted and operating television receiver.

Place the Channel Switch on the Odyssey to either Channel 3 or 4 and the television VHF Channel Selector to the same channel. The Channel Switch on the Odyssey is located to the right of the battery compartment.

Place the Power Switch in the "On" position, the Game Switch to the middle (Tennis) position, and fine tune the television receiver if necessary. A typical Tennis Court should be seen on the television screen. (Adjustment of Center Wall, Left and Right Player Horizontal and Vertical Controls may be necessary). The "Ball" will be served automatically.

The Game is then played by each opponent operating the Vertical Player, Horizontal Player, and Ball Control for his

side of the court. A rebound circuit keeps the "Ball" from going off the top and bottom of the screen.

The BG7616 uses electronic digital on screen scoring and will appear in the upper middle of the television screen. The score will remain on the screen a short time and then disappear and the "Ball" will automatically serve. Each score will advance digitally until the first contestant to achieve 20 points is the winner, and a "W" will be displayed on his side of the screen. Before starting a new game, reset the score to read 0-0 by sliding the PLAYER/RESET Switch to the other position.

The 4 player operation is the same as for 2 players except no control is provided for direct control of the second player in each court. The horizontal position for these players are preset (see Service Adjustments), however, they will follow the vertical movement of the primary player.

TOP VIEW OF BG7516

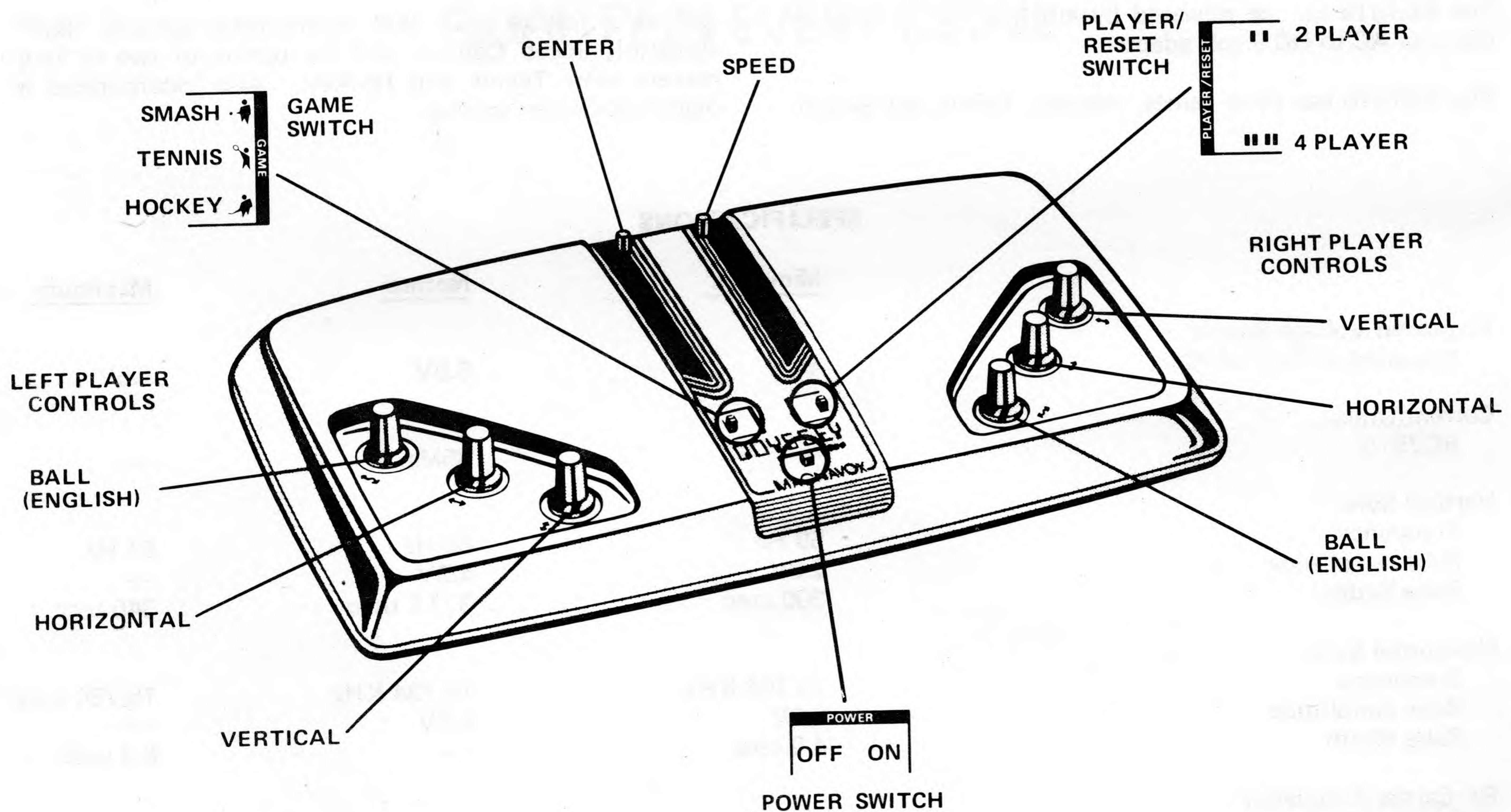

VOLTAGE CHARTS / IC FUNCTIONS

(IC1)		
PIN	VOLTAGE	NOTE
1	0V	----
2	9.6V	----
3	5.2V	----
4	0V	----
5	2.4V	4
6	.9V	4
7	1.4V	5
8	0V	----
9	.8V	----
10	.4V	----
11	3.8V	----
12	2.4V	----
13	3.6V	7
14	.1V	----
15	5.3V	----
16	.8V	----
17	2.9V	----
18	2.3V	----

(IC2)		
PIN	VOLTAGE	NOTE
1	.4V	----
2	5.3V	----
3	3.4V	8
4	2.3V	----
5	2.6V	10
6	3.7V	----
7	1.5V	----
8	.08V	----
9	.08V	----
10	4.7V	----
11	0V	----
12	2.6V	11
13	.8V	----
14	2.4V	9
15	0V	----
16	.08V	----

(IC3)		
PIN	VOLTAGE	NOTE
1	.4V	----
2	5.3V	----
3	2.7V	1
4	1.5V	1
5	2.6V	2
6	3.7V	----
7	1.4V	----
8	.08V	----
9	.18V	----
10	1.3V	----
11	5.3V	----
12	2.4V	6
13	1.4V	----
14	2.6V	3
15	0V	----
16	.08V	----

(IC4)		
PIN	VOLTAGE	NOTE
1	.4V	----
2	5.2V	----
3	3.4V	12
4	2.3V	----
5	2.6V	10
6	3.7V	----
7	.4V	----
8	.05V	----
9	.05V	----
10	.38V	----
11	3V	----
12	2.5V	11
13	.76V	----
14	2.1V	13
15	0V	----
16	.07V	----

(IC5)		
PIN	VOLTAGE	NOTE
1	5.2V	----
2	1.8V	14
3	.4V	----
4	.09V	----
5	1.3V	----
6	.03V	----
7	.06V	----
8	.07V	----
9	.05V	----
10	1.5V	----
11	0V	----
12	.7V to 4.5V	1
13	.7V to 4.5V	1
14	.3V to 4.5V	1
15	.2V	----
16	.08V	----

(IC6)		
PIN	VOLTAGE	NOTE
1	5.2V	----
2	.7V to 4.5V	1
3	.03V	----
4	2.6V	----
5	0V	----
6	.01V	----
7	1.4V	----
8	1.4V	----
9	.0V	----
10	0V	----
11	.08V	----
12	0V	----
13	0V	----
14	1.4V	----
15	.9V	----
16	.4V	----

(IC7)		
PIN	VOLTAGE	NOTE
1	.17V	----
2	.03V	----
3	0V	----
4	0V	----
5	0V	----
6	5.2V	----
7	0V	----
8	0V	----
9	.4V	----
10	0V to 5.2V	1
11	0V to 5.2V	1
12	.9V to 4.2V	1
13	0V	----
14	5.2V	----

TRANSISTOR		VOLTAGE	NOTE
Q1	E	0V	----
	B	.7V	----
	C	1V	----
Q2	E	0V	----
	B	.7V	----
	C	0V	----
Q4	E	0V	----
	B	.35V to .65V	1
	C	0V to 5.2V	1
Q5	E	9.7V	----
	B	9.7V	----
	C	0V to .1V	1
Q13	E	0V	----
	B	0V	----
	C	5.2V	----

NOTES:

VOLTAGES TAKEN WITH VTVM, GAME SWITCH IN MIDDLE (TENNIS) POSITION, PLAYERS SWITCH IN "2", SOUND ON, PLAYERS CENTERED AND "BALL" VOLLEYING BETWEEN, CHANNEL SWITCH ON 3.

- Voltage varies with Ball Speed & Distance Traveled.
- Voltage varies with Right or Left Ball Control.
- Voltage varies with Left Wall Position Control.
- Voltage varies with Lower Rebound Control.
- Voltage varies with Upper Rebound Control.
- Voltage varies with Goal Position Control.
- Voltage varies with Right Wall Position Control.
- Voltage varies with Right Player Horizontal Position.
- Voltage varies with Left Player Horizontal Position.
- Voltage varies with Right Player Vertical Position.
- Voltage varies with Left Player Vertical Position.
- Voltage varies with Right Fixed Player Position.
- Voltage varies with Left Fixed Player Position.
- Voltage varies with Blanking Centering & Width.

IC1

- Voltage Regulator
- Vertical Sync Generator
- Horizontal Sync Generator
- Right Wall Generator
- Rebound Circuitry

IC2

- Right Player Generator
- Left Player Generator

IC3

- Left Wall Generator
- Ball Generator

IC4

- Right Back Court Player Generator
- Left Back Court Player Generator

IC5

- Video Summer
- Video Output
- Audio Pulse Generator
- Logic Circuitry

IC6

- Automatic Scoring Circuitry

IC7

- Automatic Serving Circuitry

TOP VIEW
(SERVICE ADJUSTMENTS)

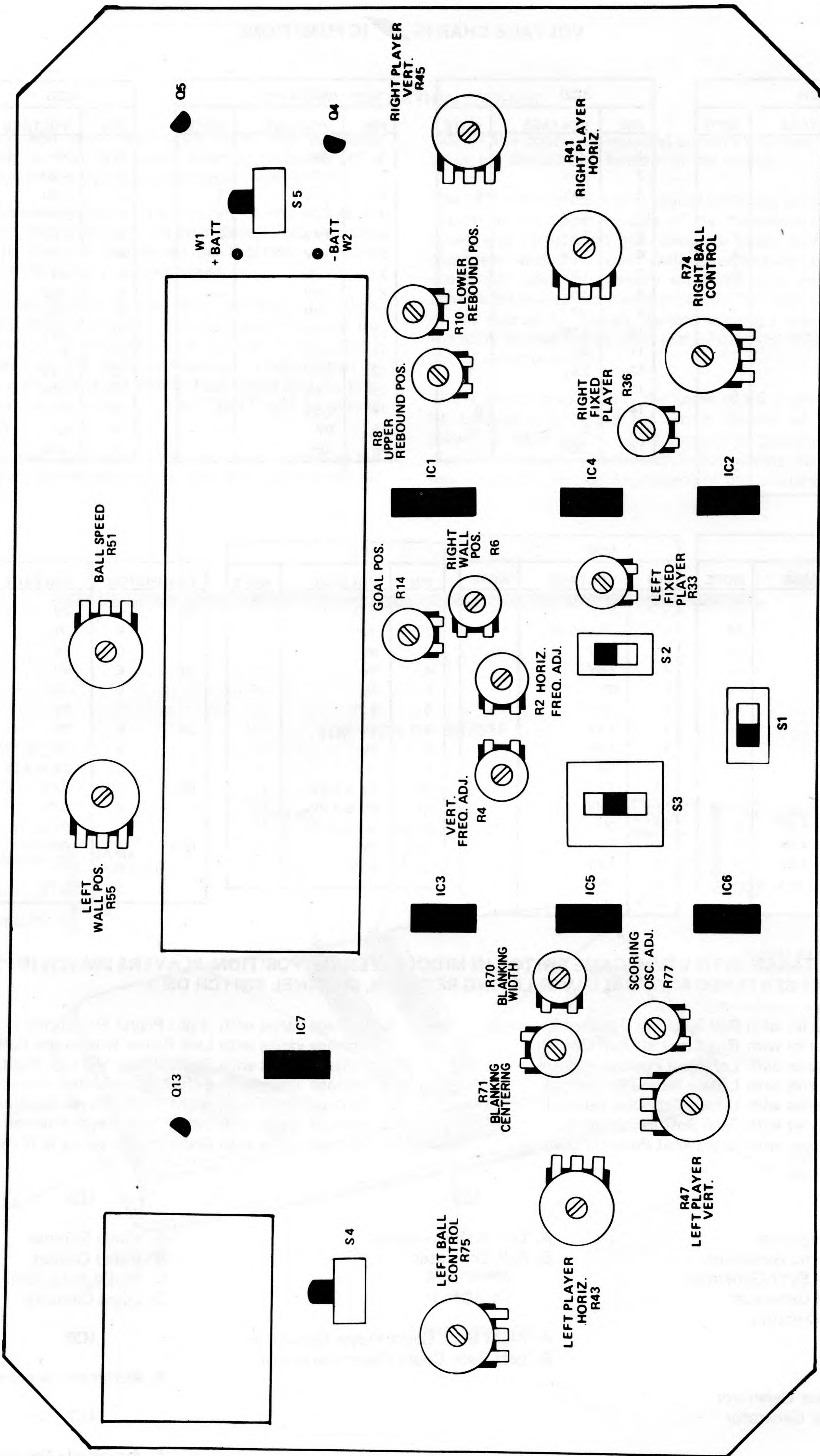

MAIN P.C. BOARD (COMPONENT VIEW)

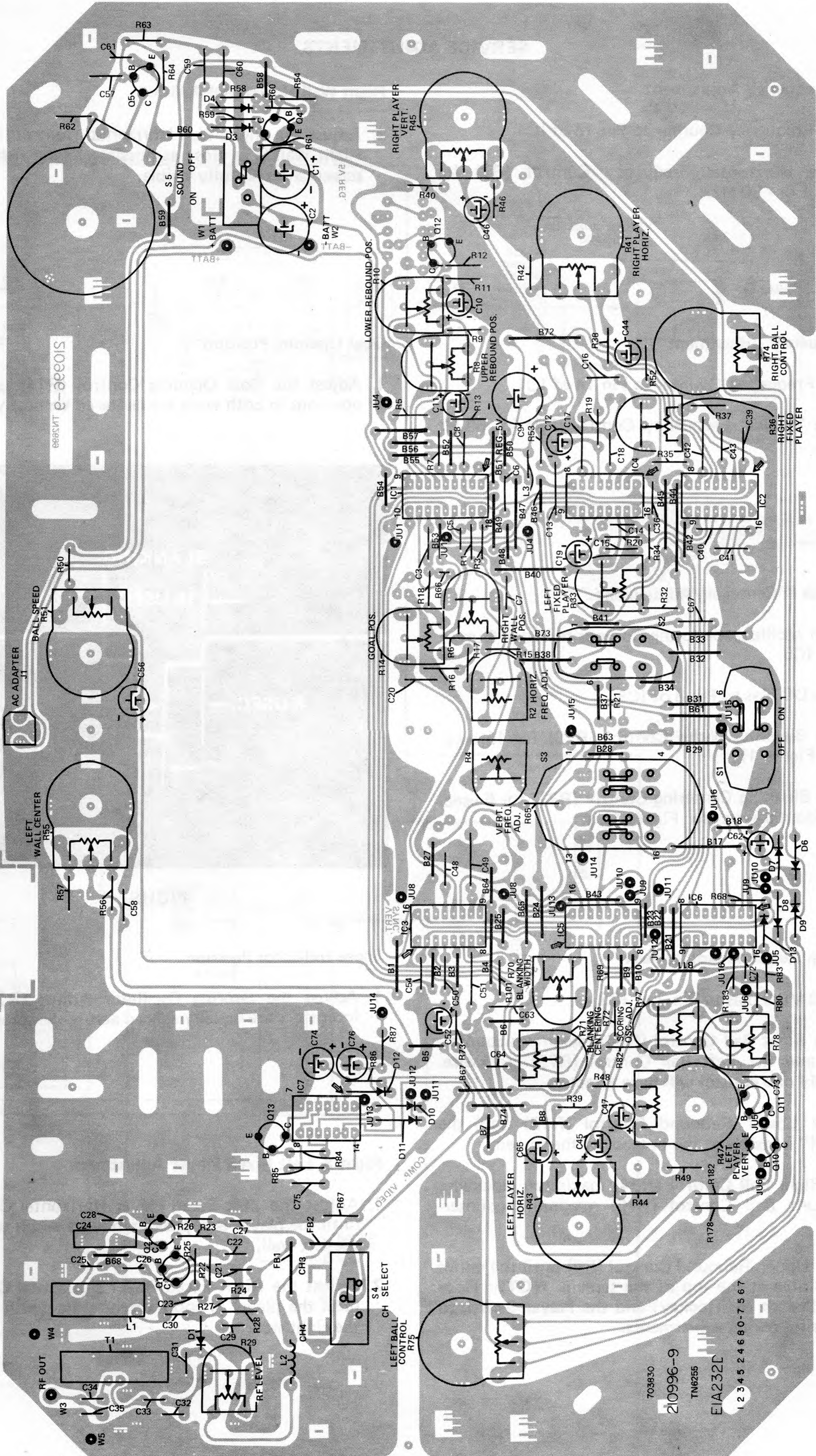

703830

210996-9

TN6255

EIA232C

1 2 3 4 5 2 4 6 8 0 - 7 5 6 7

SERVICE ADJUSTMENTS

Horizontal Frequency Adjustment

1. Connect a Frequency Counter to Pin 16 of IC1.
2. Adjust the Horizontal Frequency Control (R2) for 15,734 Hz + or - 30 Hz.

Vertical Frequency Adjustment

1. Connect a Frequency Counter to Pin 14 of IC1.
2. Adjust the Vertical Frequency Control (R4) for 60 Hz + or - 1 Hz.

Blanking Width & Centering Adjustment

1. Connect an oscilloscope to the Composite Video Output at Pin 5 of IC5.
2. Apply +3 VDC bias to Pin 8 of IC5.
3. Adjust the Blanking Width Control (R70) for 16 usec. width (see Figure 1).
4. Adjust the Blanking Centering Control (R71) for 6 usec. before horizontal sync (see Figure 1).

Top & Bottom Rebound Adjustment

1. Connect 3 VDC bias to Pin 3 of IC3.
2. Rotate the Right Ball Control (R74) maximum counter-clockwise and the Left Ball Control (R75) clockwise. **NOTE: Only one control will have effect.**
3. Adjust the Lower Rebound Control (R10) until the entire "Ball" is visible at the bottom of the screen.
4. Turn the Right Ball Control (R74) maximum clockwise and the Left Ball Control (R75) maximum counter-clockwise.
5. Adjust the Upper Rebound Control (R9) until the entire "Ball" is visible at the top of the screen. **NOTE: Place the Game Switch to (Hockey) and the Player Switch to "4" for the following adjustments:**

Right Wall Horizontal Position

1. Adjust the Right Wall Horizontal Control (R6) until the Right Wall is as close as possible to the right side of the screen and still fully visible.

Goal Opening Position

1. Adjust the Goal Opening Control (R14) until the goal openings in both walls are centered vertically.

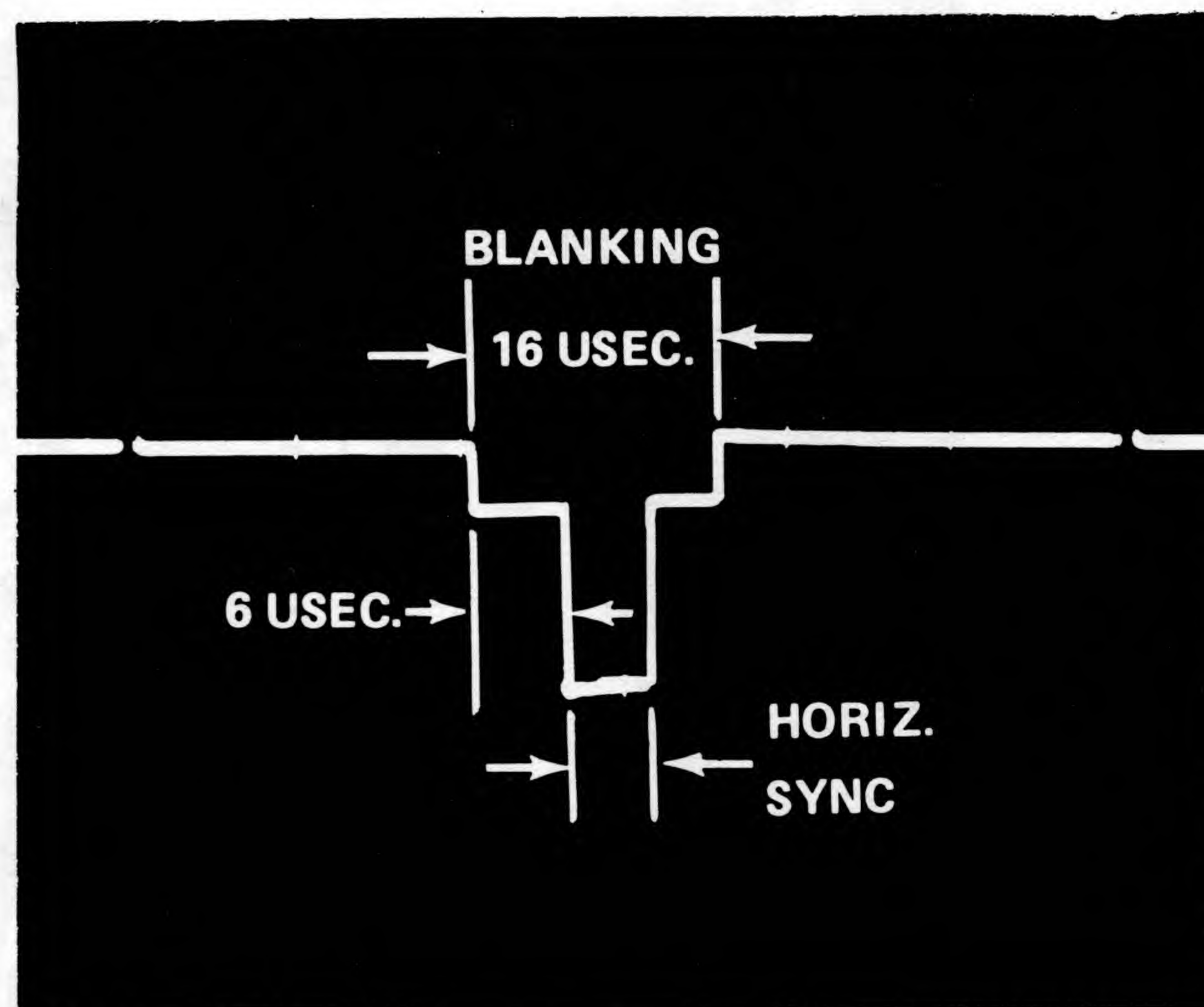

FIGURE 1

Score Indicator Position

1. Adjust the Scoring Oscillator Adjust (R77) until the indicators are equally spaced across the screen.

Right & Left Fixed Player Adjustment

1. Adjust the Left Fixed Player Horizontal Control (R33) until the player is approximately its width to the right of the left wall.
2. Adjust the Right Fixed Player Horizontal Control (R36) until the player is approximately its width to the left of the right wall.

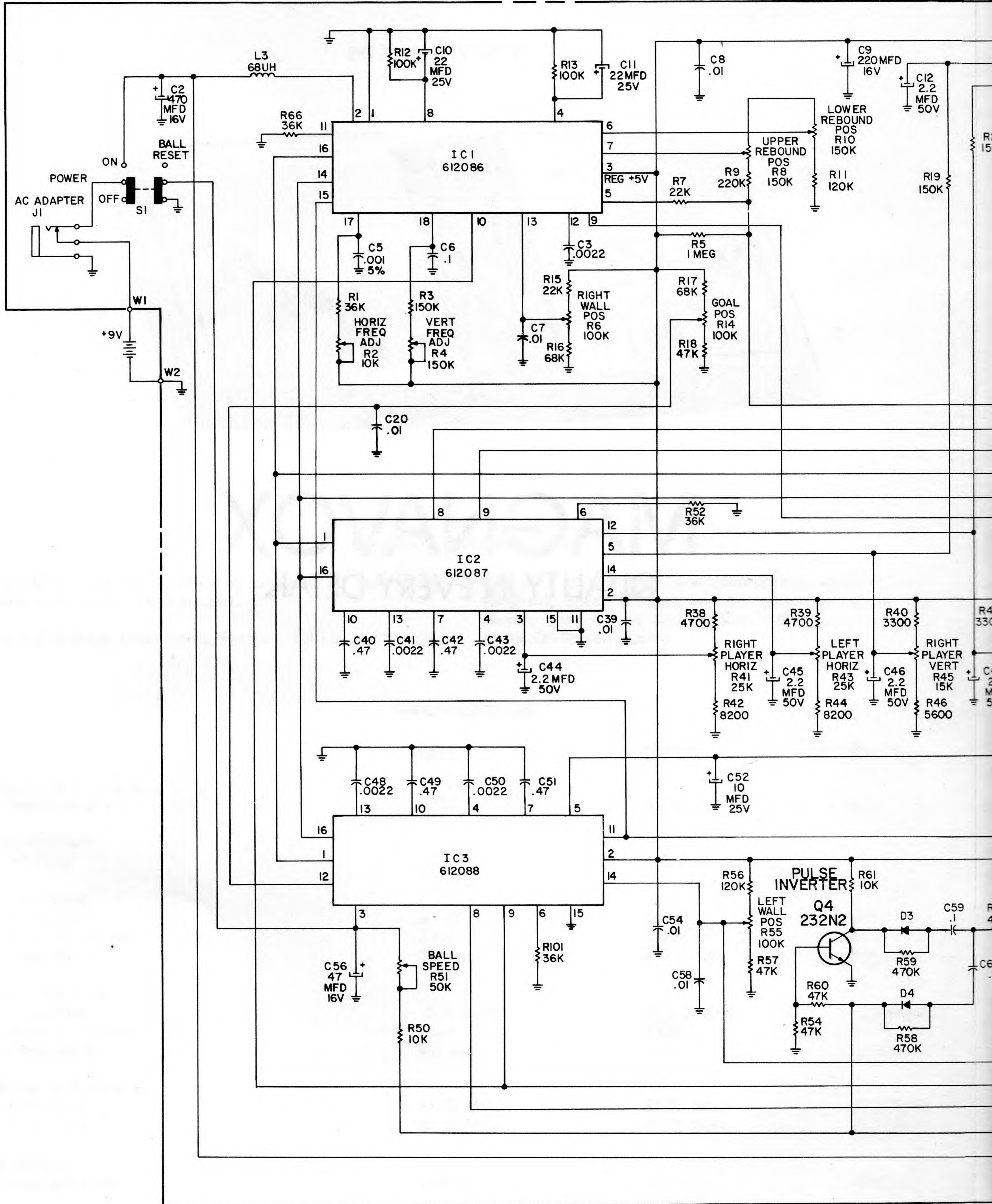

BG7516 SCHEMATIC DIAGRAM

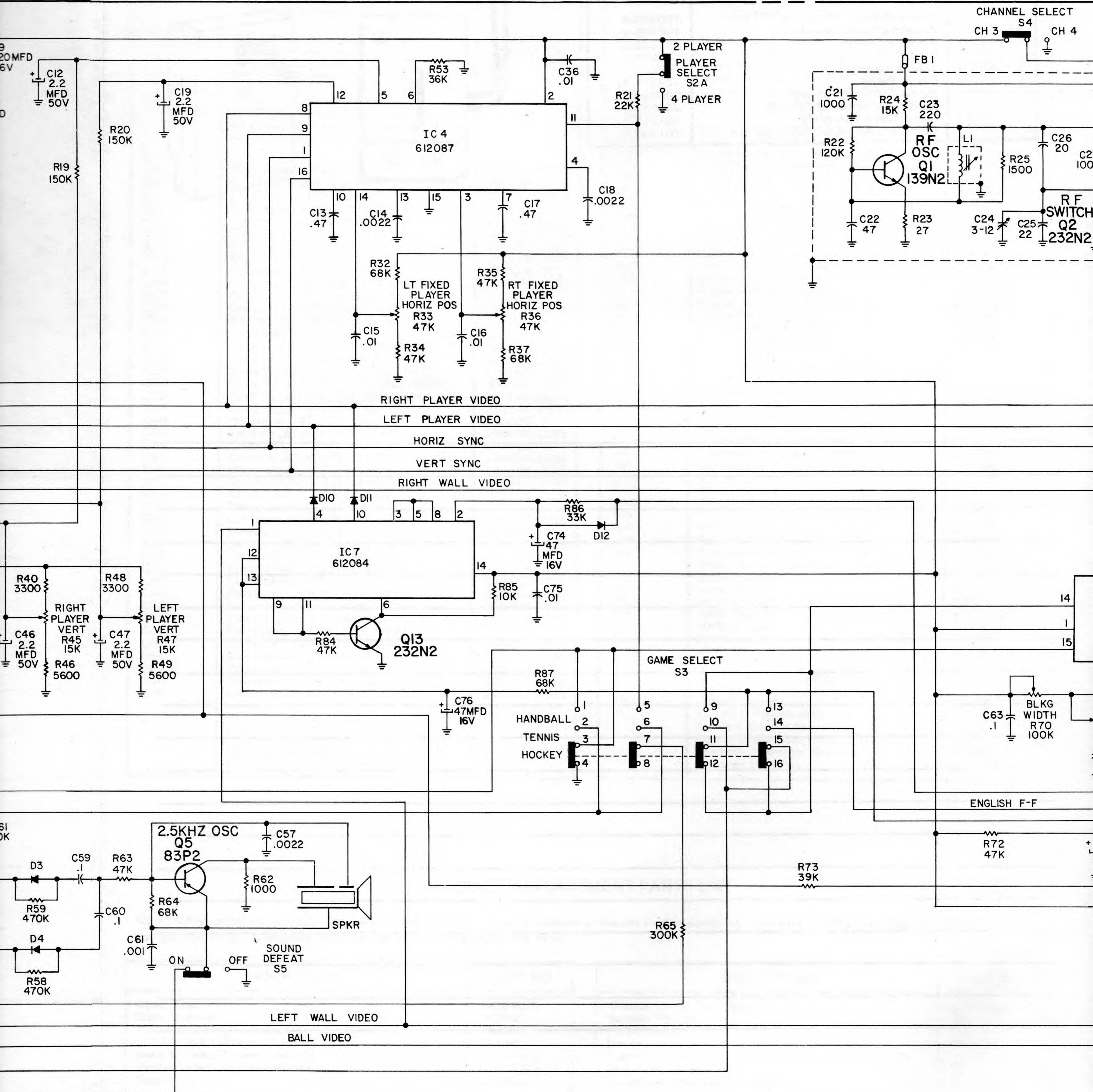

BG7516 REPLACEMENT PARTS LIST

Note: When ordering replacement parts please specify the part number as shown in this list including Description, Chassis, and Model Number. Complete information will help expedite the order. Replacement parts may occasionally differ in part number or value from the Factory installed part. In either event the replacement part has been chosen to provide equal or improved performance.

REF.	DESCRIPTION	PART NO.	REF.	DESCRIPTION	PART NO.
	COILS & TRANSFORMERS			CONTROLS & SWITCHES	
L1	Oscillator Coil	361495-2	R2	Horizontal Frequency Adjust, 10K	220300-1032
L2	12 uh Peaking Coil	361425-120	R4	Vertical Frequency Adjust, 150K	220300-1543
L3	68 uh Peaking Coil	361475-680	R6	Right Wall Position, 100K	220300-1043
T1	RF Transformer	361467-2	R8	Upper Rebound Position, 150K	220300-1542
	CAPACITORS		R10	Lower Rebound Position, 150K	220300-1542
	Values, tolerances & voltage ratings for capacitors not listed are shown on the schematic, or are 10%, 500V.		R14	Goal Position, 100K	220300-1043
C2	Electrolytic, 470 mfd., 16V	270109-5215	R29	R-F Level, 220 ohm	220300-2213
C3	Ceramic, 2200 pfd, 5%, 500V	250551-2225	R33	Left Fixed Player, 47K	220300-4733
C5	Polyester, 1000 pfd., 5%, 150V	250635-1025	R36	Right Fixed Player, 47K	220300-4733
C6	Polyester, .1 mfd., 10%, 100V	250654-1049	R41	Right Player Horizontal, 25K	220337-5
C9	Electrolytic, 220 mfd., 16V	270109-2215	R43	Left Player Horizontal, 25K	220337-5
C10	Electrolytic, 22 mfd., 25V	270111-2125	R45	Right Player Vertical, 15K	220337-4
C11	Electrolytic, 22 mfd., 25V	270111-2125	R47	Left Player Vertical, 15K	220337-4
C12	Electrolytic, 2.2 mfd., 50V	270109-2050	R51	Ball Speed, 50K	220311-10
C13	Polyester, .47 mfd., 5%, 11V	250600-13	R55	Left Wall Center, 100K	220311-11
C14	Ceramic, 2200 pfd., 5%, 500V	250551-2225	R70	Blanking Width, 100K	220300-1043
C17	Polyester, .47 mfd., 5%, 11V	250600-13	R71	Blanking Center, 4700 ohm	220300-4723
C18	Ceramic, 2200 pfd., 5%, 500V	250551-2225	R74	Right Ball Control, 50K	220337-6
C19	Electrolytic, 2.2 mfd., 50V	270109-2050	R75	Left Ball Control, 50K	220337-6
C24	Trimmer, 3-15 pfd.	250371-6	R77	Scoring Oscillator Adjust, 22K	220300-2233
C25	Ceramic, 22 pfd., 5%, 500V, NPO	250546-2205	S1	Power/On-Off Switch	160546-3
C26	Ceramic, 20 pfd., 5%, 500V, NPO	250546-2005	S2	Player Select/Score Reset Switch	160546-3
C29	Ceramic, 15 pfd., 10%, 500V, NPO	250546-1509	S3	Game Select Switch	160546-2
C30	Ceramic, 1.2 pfd., .1%, 500V, NPO	250546-1296	S4	Channel Select Switch	160556-1
C33	Ceramic, 33 pfd., 5%, 500V, NPO	250546-3305	S5	Sound Defeat Switch	160556-1
C34	Ceramic, 27 pfd., 5%, 500V, NPO	250546-2705		SEMICONDUCTORS	
C40	Polyester, .47 mfd., 5%, 11V	250600-13	D1	Germanium Diode	530105-1001
C41	Ceramic, 2200 pfd., 5%, 500V	250551-2225	D3	Silicon Diode	530181-1001
C42	Polyester, .47 mfd., 5%, 11V	250600-13	D4	Silicon Diode	530181-1001
C43	Ceramic, 2200 pfd., 5%, 500V	250551-2225	D6	Germanium Diode Detector	530065-1002
C44	Electrolytic, 2.2 mfd., 50V	270109-2050	D7	Germanium Diode Detector	530065-1002
C45	Electrolytic, 2.2 mfd., 50V	270109-2050	D8	Germanium Diode Detector	530065-1002
C46	Electrolytic, 2.2 mfd., 50V	270109-2050	D9	Germanium Diode Detector	530065-1002
C47	Electrolytic, 2.2 mfd., 50V	270109-2050	D10	Silicon Diode	530181-1001
C48	Ceramic, 2200 pfd., 5%, 500V	250551-2225	D11	Silicon Diode	530181-1001
C49	Polyester, .47 mfd., 5%, 11V	250600-13	D12	Silicon Diode	530181-1001
C50	Ceramic, 2200 pfd., 5%, 500V	250551-2225	IC1	Voltage Reg./Sync. Generator	612086-1
C51	Polyester, .47 mfd., 5%, 11V	250600-13	IC2	Player Generator	612087-1
C52	Electrolytic, 10 mfd., 25V	270111-1125	IC3	Ball/Wall Generator	612088-1
C56	Electrolytic, 47 mfd., 16V	270111-5115	IC4	Player Generator	612087-1
C59	Polyester, .1 mfd., 10%, 100V	250654-1049	IC5	Video Summer/Logic	612089-1
C60	Polyester, .1 mfd., 10%, 100V	250654-1049	IC6	Scoring Logic	612108-1
C62	Electrolytic, 4.7 mfd., 50V	270111-5050	IC7	Auto Serve	612084-1
C63	Polyester, .1 mfd., 10%, 100V	250654-1049	Q1	NPN Silicon	610139-2
C64	Polyester, 1000 pfd., 5%, 150V	250635-1025	Q2	NPN Silicon	610232-2
C65	Electrolytic, 10 mfd., 25V	270111-1125	Q4	NPN Silicon	610232-2
C67	Polyester, .1 mfd., 10%, 100V	250654-1049	Q5	PNP Silicon	610083-2
C74	Electrolytic, 47 mfd., 16V	270111-5115	Q13	NPN Silicon	610232-2
C76	Electrolytic, 47 mfd., 16V	270111-5115		MISCELLANEOUS	
	RESISTORS		FB1,2	Ferrite Beads	364005-1
	Values, tolerances & wattages for resistors not listed are shown on the schematic, or are 5%, 1/4W.		J1	External Power Jack	181139-2
				Battery Connector	181096-3
				Game Cable Assembly	461218-5
				Speaker (Ceramic Crystal)	560406-1
				Speaker Housing	181189-1

CABINET REPLACEMENT PARTS LIST

Note: When ordering replacement parts, please specify the part number as shown in this parts list including Description, Chassis Number, Model and Run Number. Complete information will help expedite the order.

DESCRIPTION	PART NO.	DESCRIPTION	PART NO.
Case, Top	143670-5	Chassis Cover (Cardboard)	643602-3
Case, Bottom	143669-5	Battery Holder	142658-1
Knob, Control	143689-8	Foot, Black	141737-3
Switch Inlay (Player Switch)	151449-1	Spring Lock Nut	103235-1
Switch Inlay (Power Switch)	151449-2	Fastener Stud	732953-2
Switch Inlay (Game Switch)	151449-3	Retainer O-Ring	103082-4
Top Inlay	151483-2	Customer Operating Booklet	1B2985-1

MAGNAVOX
QUALITY IN EVERY DETAIL