

TOSHIBA

FILE NO. 120-9601

Handwritten mark

SERVICE MANUAL

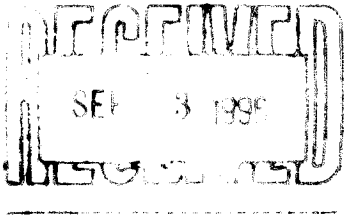

VIDEO CASSETTE RECORDER

M-672, M-672C

M-65, M-65C

M-662, M-662C

M-472, M-45

M-462

2. DISASSEMBLY & REASSEMBLY

2-1. INSTRUMENT DISASSEMBLY

2-1-1. Bottom Cover Removal

1. Remove two (2) screws holding the bottom cover.
2. Release two (2) tabs from the bottom cover.

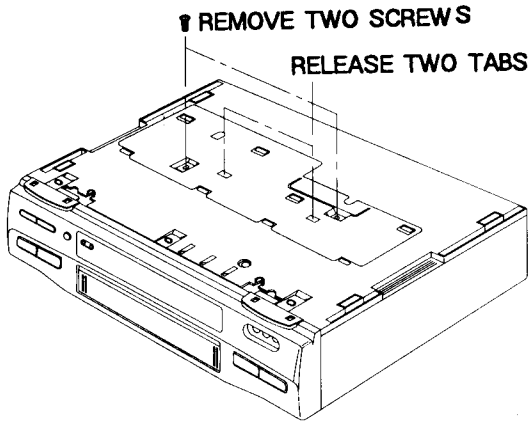

Fig. 1 Bottom Cover Removal

2-1-2. Top Cabinet Removal

1. Remove three(3)screws located at the rear of the top cabinet.
2. Carefully lift the back of the top cabinet and slide it to the rear to remove.

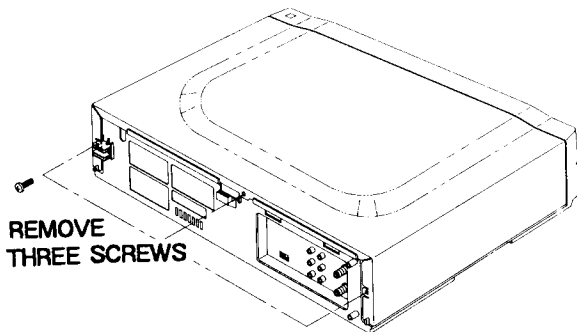

Fig. 2 Top Cover Removal

2-1-3. Front Panel Removal

1. Remove bottom cover and top cabinet (See Fig. 1 to 2).
2. Release three (3) tabs from the bottom of the front panel.
3. Release four (4) tabs from the top of the front panel.
4. Tilt the front panel forward to remove.

NOTE : First, release three (3) tabs from the bottom completely and then release four (4) tabs from the top of the front panel.

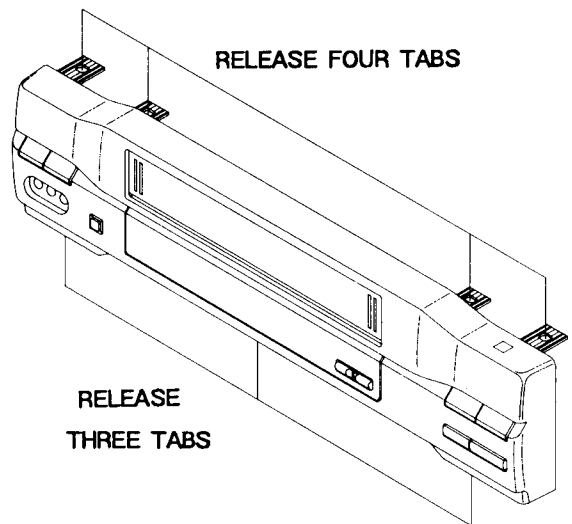

Fig. 3 Front Panel Removal

2-2. CIRCUIT BOARD DISASSEMBLY

2-2-1. Function PCB Removal

1. Follow the procedures for removing the bottom cover, the top cabinet and the panel front. (See Fig.1 to 3)
2. Release five (5) tabs on the function board.
3. Release connector(CN701) gently with using the Driver as shown Fig. 4

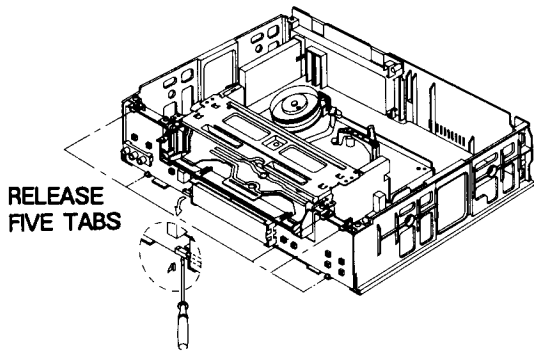

Fig. 4 Function PCB Removal

2-2-2. Deck Ass'y Removal

1. Follow the procedures for removing the bottom cover, top cabinet and the front panel ass'y. (See Fig.1 to 3)
2. Remove four (4) screws from the bottom and top of the deck ass'y.
3. Remove two (2) screws from the bottom of the frame.
4. Lift the deck ass'y upward to remove.

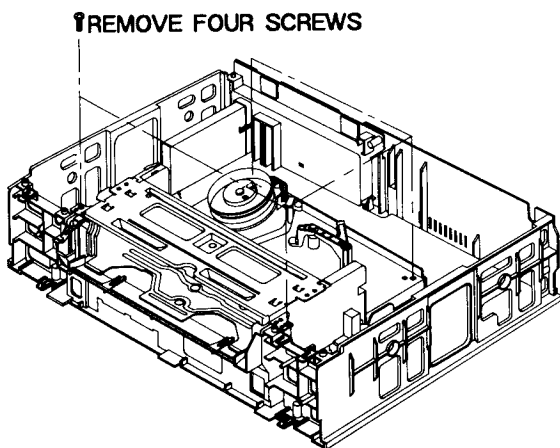

Fig. 5 Deck ass'y Removal

2-2-3. Main circuit board Removal

1. Follow the procedures for removing Fig. 1 to 6
2. Release three (3) tabs from the frame.
3. Pull out the main circuit board in the direction of the arrow.

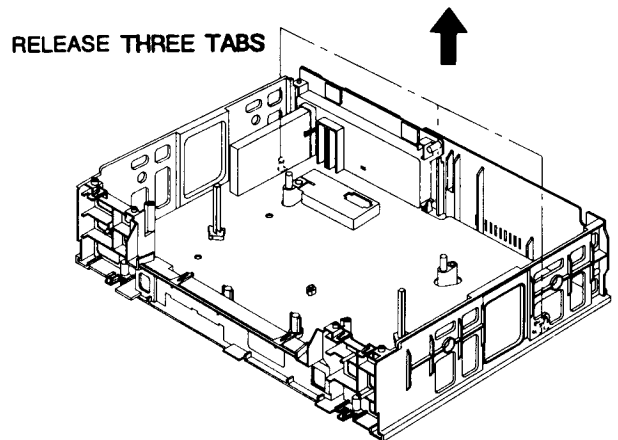

Fig. 6 Main Circuit Board Removal

2-3. INSTRUMENT ASSEMBLY REMOVAL

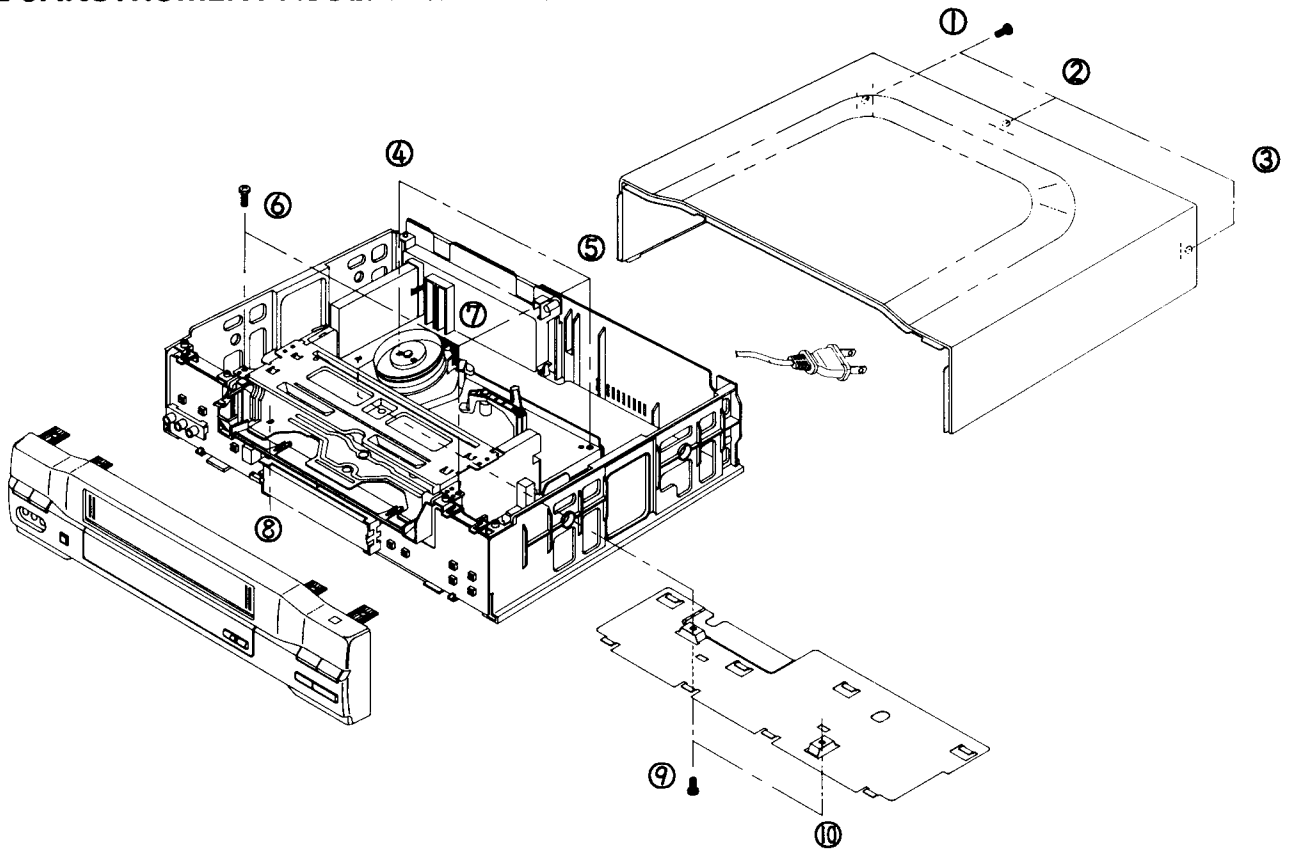

Fig. 7 Instrument Assembly Removal

1. Remove screws (⑨, ⑩) and release the bottom cover.
2. Remove screws (①, ②, ③) and release the top cover.
3. Release the front panel as shown in Fig. 3
4. Release connector (CN701) gently with using the Driver as shown Fig. 4
5. Remove screws (④, ⑤, ⑥, ⑦, ⑧) holding the deck and follow the procedures on next page.

2-4. TROUBLESHOOTING POSTURE

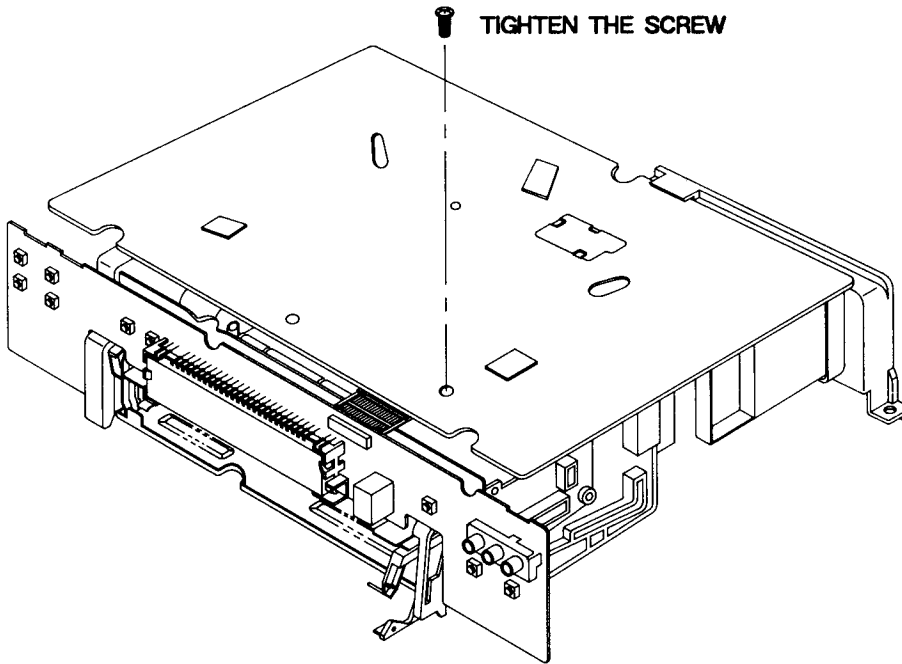

Fig. 8 TroubleShooting Posture

1. Set the main PCB & DECK ass'y as shown in Fig. 8.
2. Tighten the screw.
3. Install the Function PCB to Main PCB

NOTE : After tightening the screw, be sure to make troubleshooting.

2-5. TAPE TRANSPORT MECHANISM IDENTIFICATION

2-5-1. Deck (Top View)

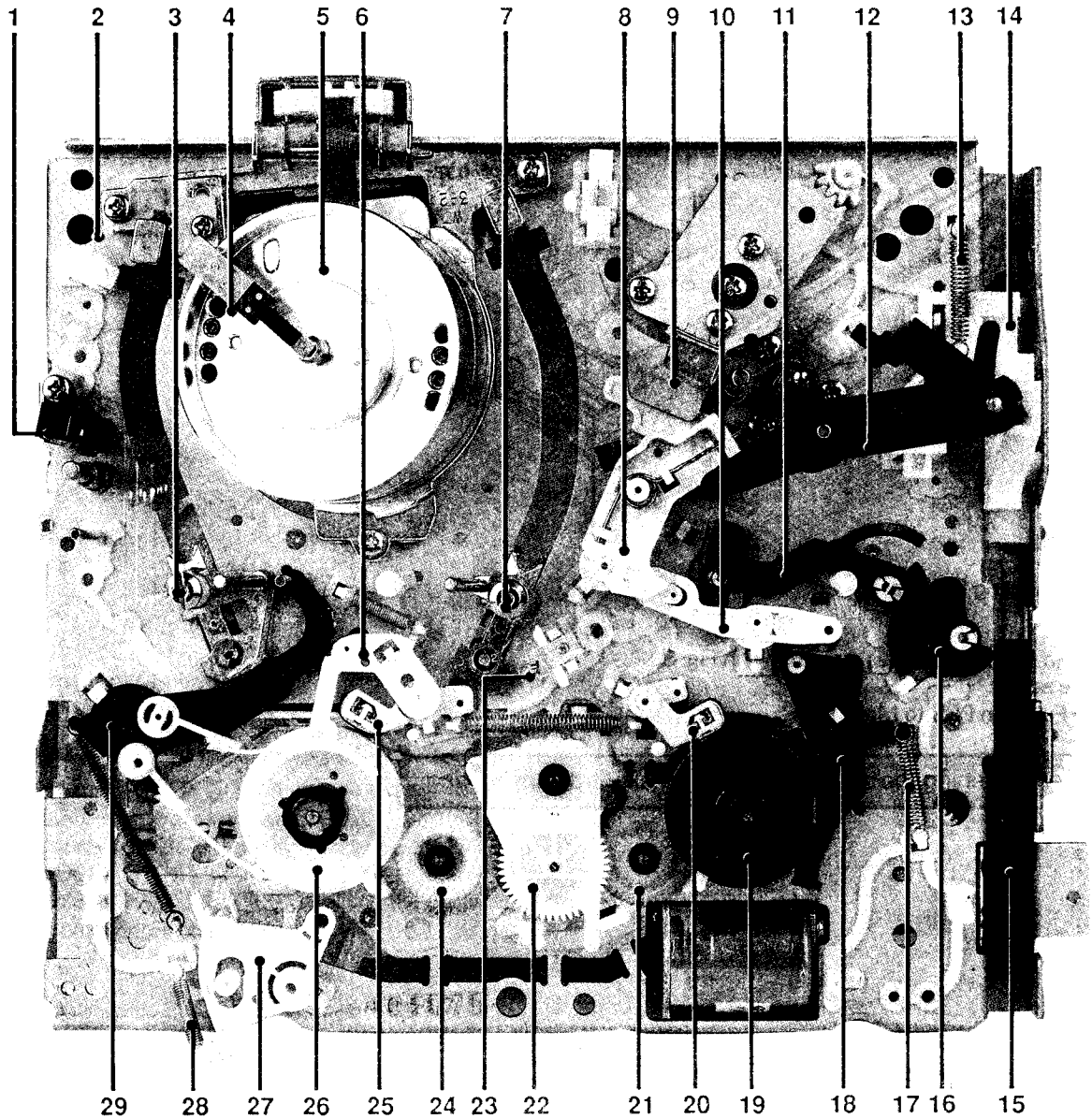

Fig.9 Deck Parts Locations (Top View)

- | | | |
|---------------------------------|-----------------------------|----------------------------|
| 1. FULL ERASE HEAD | 11. ARM REVIEW ASS'Y | 21. GEAR RELAY "T" ASS'Y |
| 2. STOPPER TAPE | 12. UNIT PINCH ROLLER ASS'Y | 22. IDLER ASS'Y |
| 3. SLIDE GEAR LOADING ASS'Y "T" | 13. SPRING SLIDE PUSH | 23. PRISM LED |
| 4. HEAD BRUSH ASS'Y | 14. SLIDE PINCH | 24. GEAR RELAY "S" ASS'Y |
| 5. CYLINDER ASS'Y | 15. SLIDE RACK HOUSING | 25. BRAKE MAIN "L" ASS'Y |
| 6. BRAKE SUB "L" | 16. LEVER REVIEW | 26. REEL DISK "L" ASS'Y |
| 7. SLIDE GEAR LOADING ASS'Y "S" | 17. SPRING BRAKE SUB "R" | 27. LEVER REC SWITCH |
| 8. LEVER PINCH COMP | 18. BRAKE SUB "R" ASS'Y | 28. SPRING REC SWITCH |
| 9. FULL ACE HEAD ASS'Y | 19. REEL DISK "R" ASS'Y | 29. ARM TENSION FULL ASS'Y |
| 10. LEVER PINCH CAM | 20. BRAKE MAIN "R" ASS'Y | |

2-5-2. Deck (Bottom View)

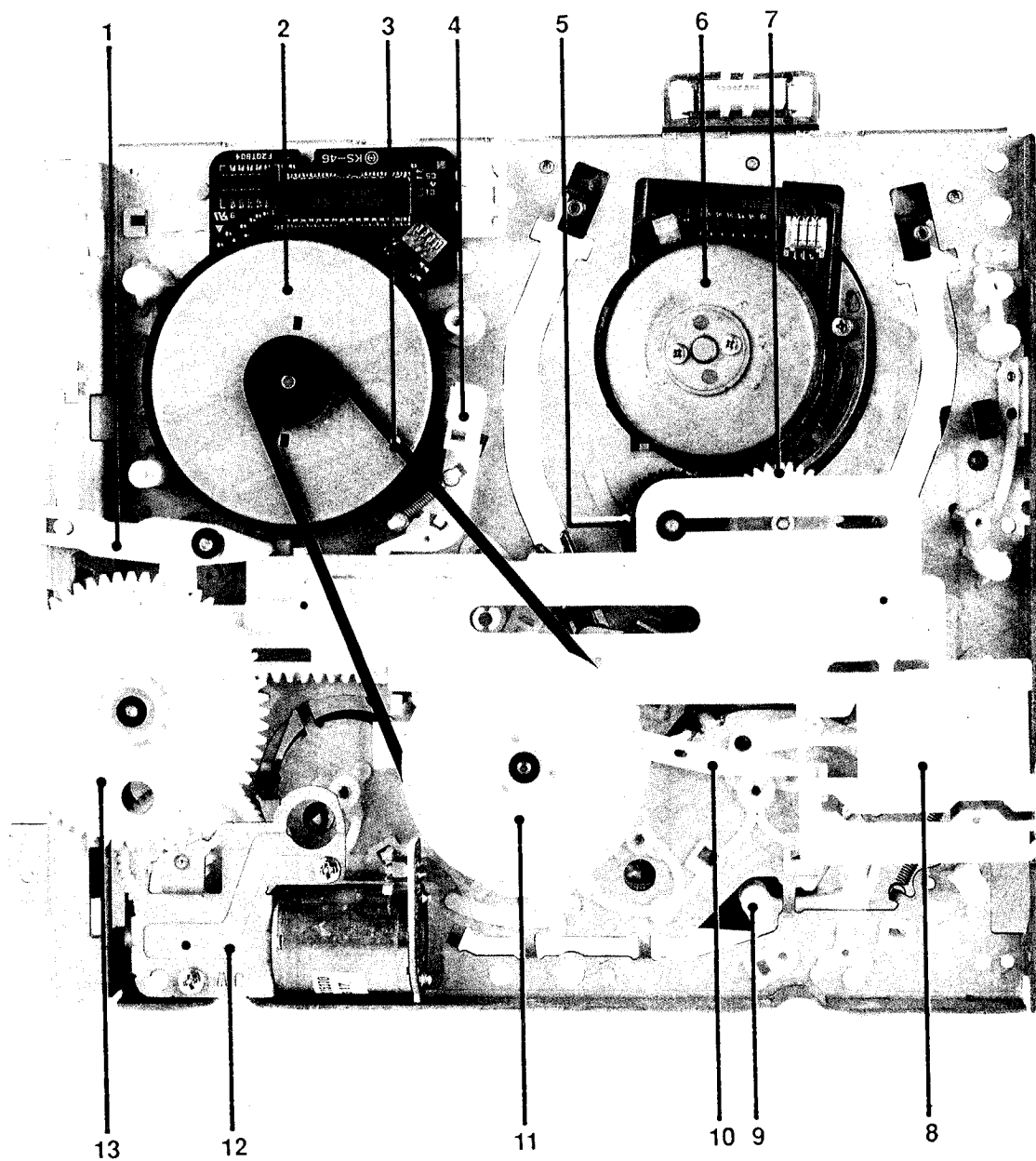

Fig. 10 Deck Parts Locations (Bottom View)

1. LEVER SLIDE PINCH
2. MOTOR D.D. CAPSTAN
3. BELT CAPSTAN
4. BRAKE CAPSTAN ASS'Y
5. GEAR LOADING "R" ASS'Y
6. MOTOR CYLINDER
7. GEAR LOADING "L" ASS'Y

8. SLIDE MAIN
9. LEVER REC SWITCH
10. LEVER IDLER CHANGE
11. CLUTCH ASS'Y
12. UNIT LOADING
13. GEAR MASTER

2-6. Housing Assembly

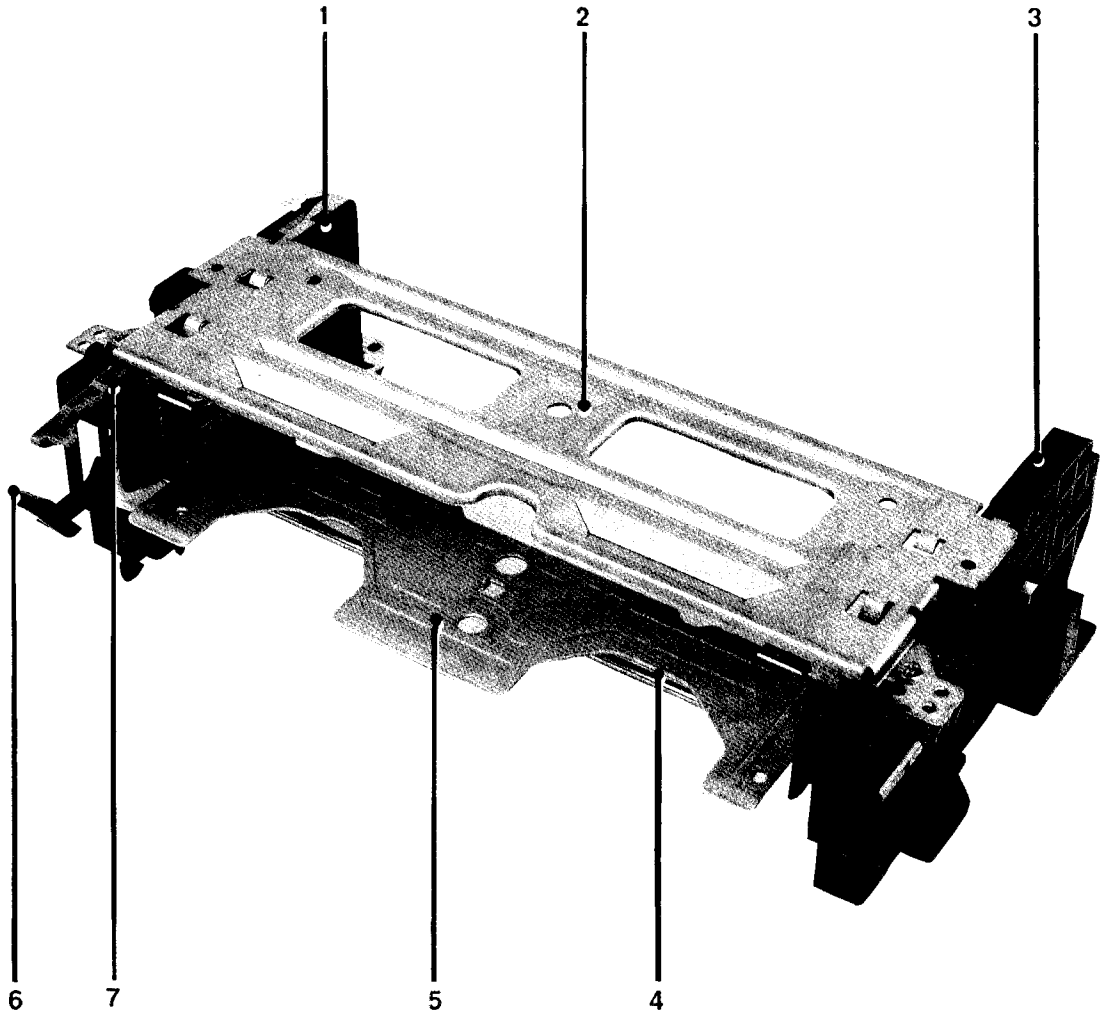

Fig. 11 Housing Parts Locations

- 1. CHASSIS SIDE "L" ASS'Y
- 2. UPPER CHASSIS
- 3. CHASSIS SIDE "R" ASS'Y
- 4. SHAFT ARM ASS'Y
- 5. HOLDER CASSETTE ASS'Y
- 6. LEVER DOOR ASS'Y
- 7. DOOR LOCK

2-6-1. Removal from Main Base

- 1) Remove three(3) screws ①.
- 2) Lift the housing ass'y in the direction of arrow "B" while pushing the tab ② in the direction of arrow "A".
(Refer to detail drawing)

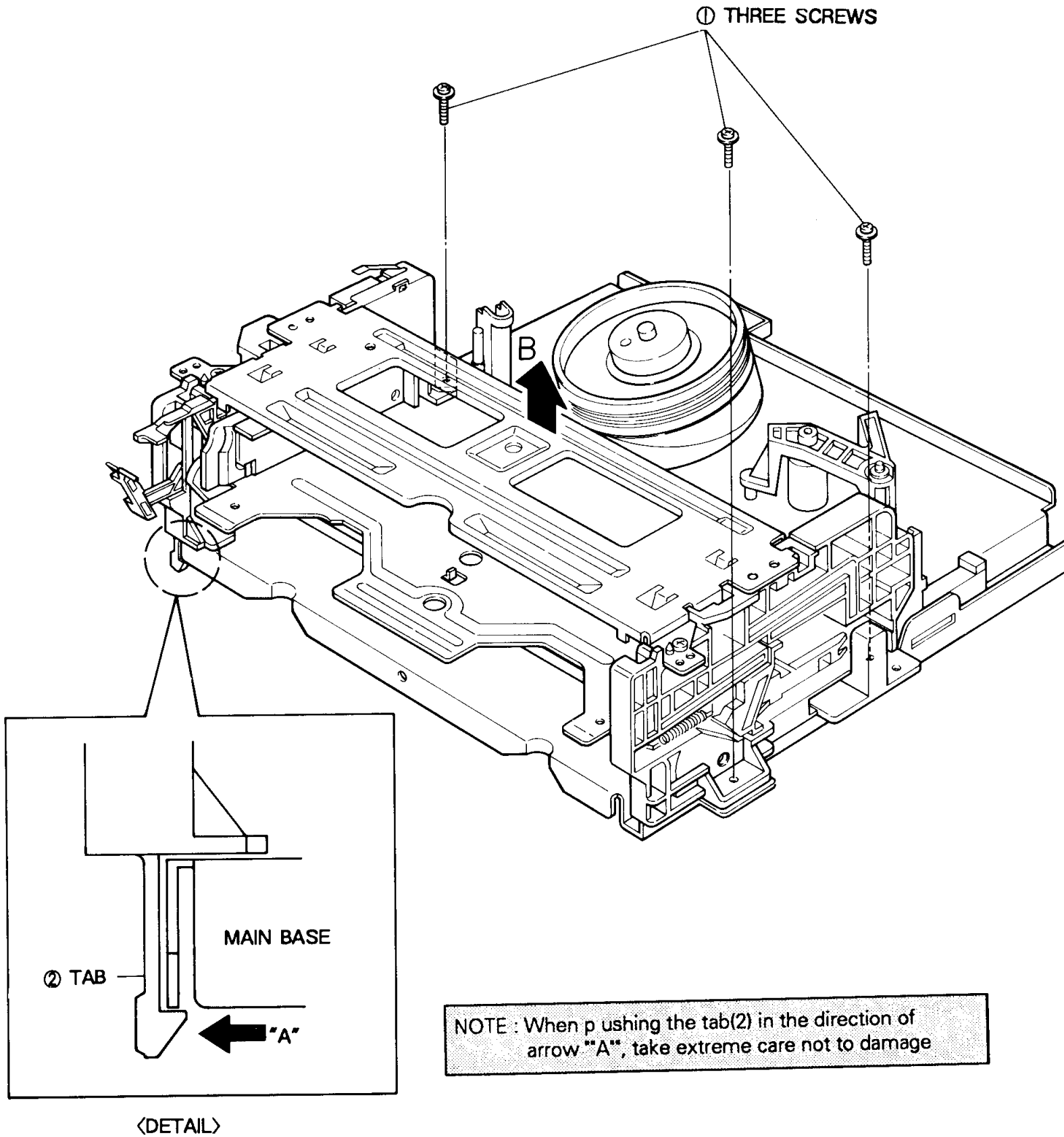

Fig. 12 Housing Ass'y Removal from Main Base

2-6-2. Disassembly

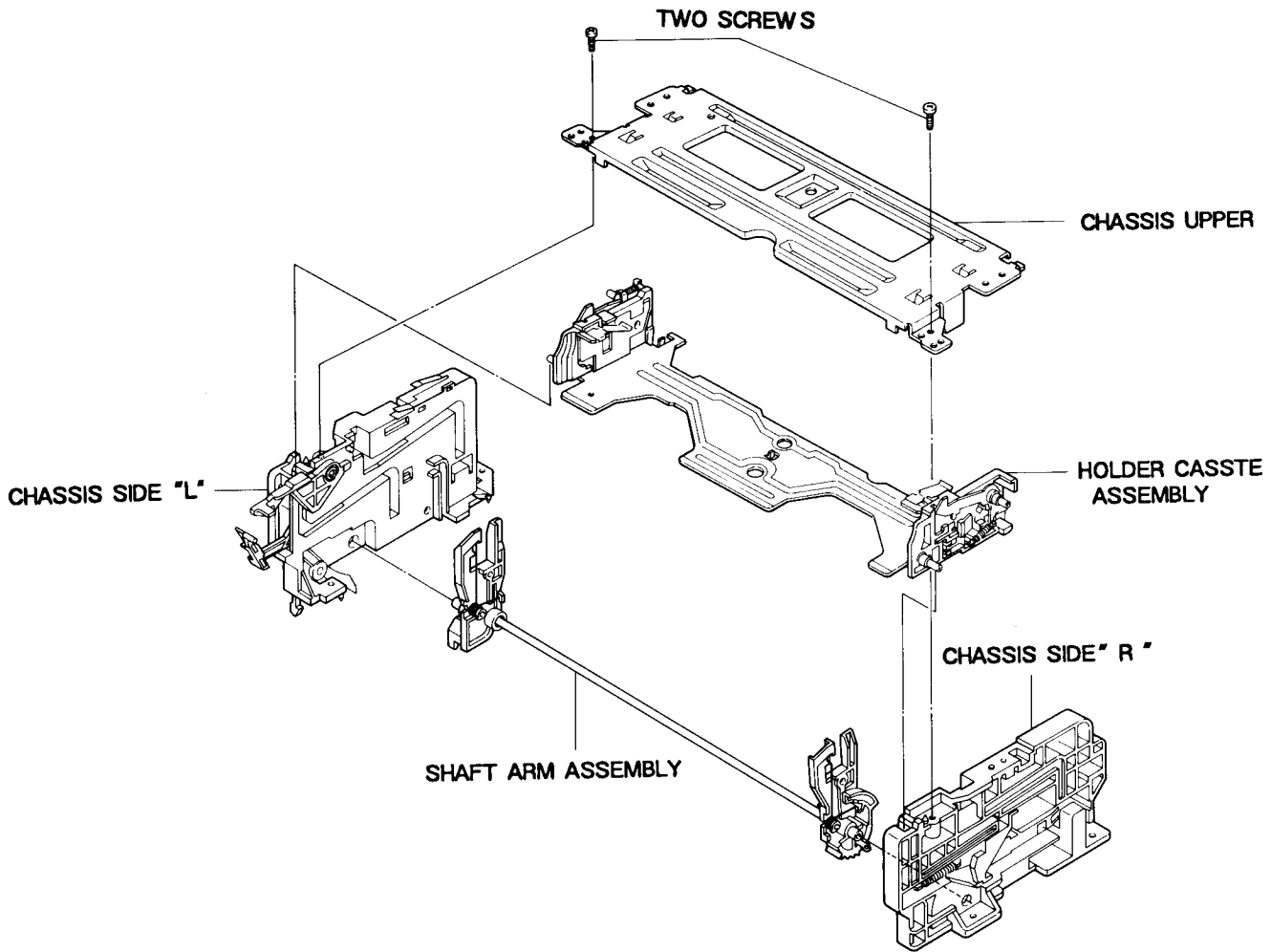

Fig. 13 Housing Ass'y Removal

2-6-3. Upper Chassis Removal

- 1) Remove two(2) screws ①.
- 2) Lift the upper chassis ② in the direction of arrow "A"

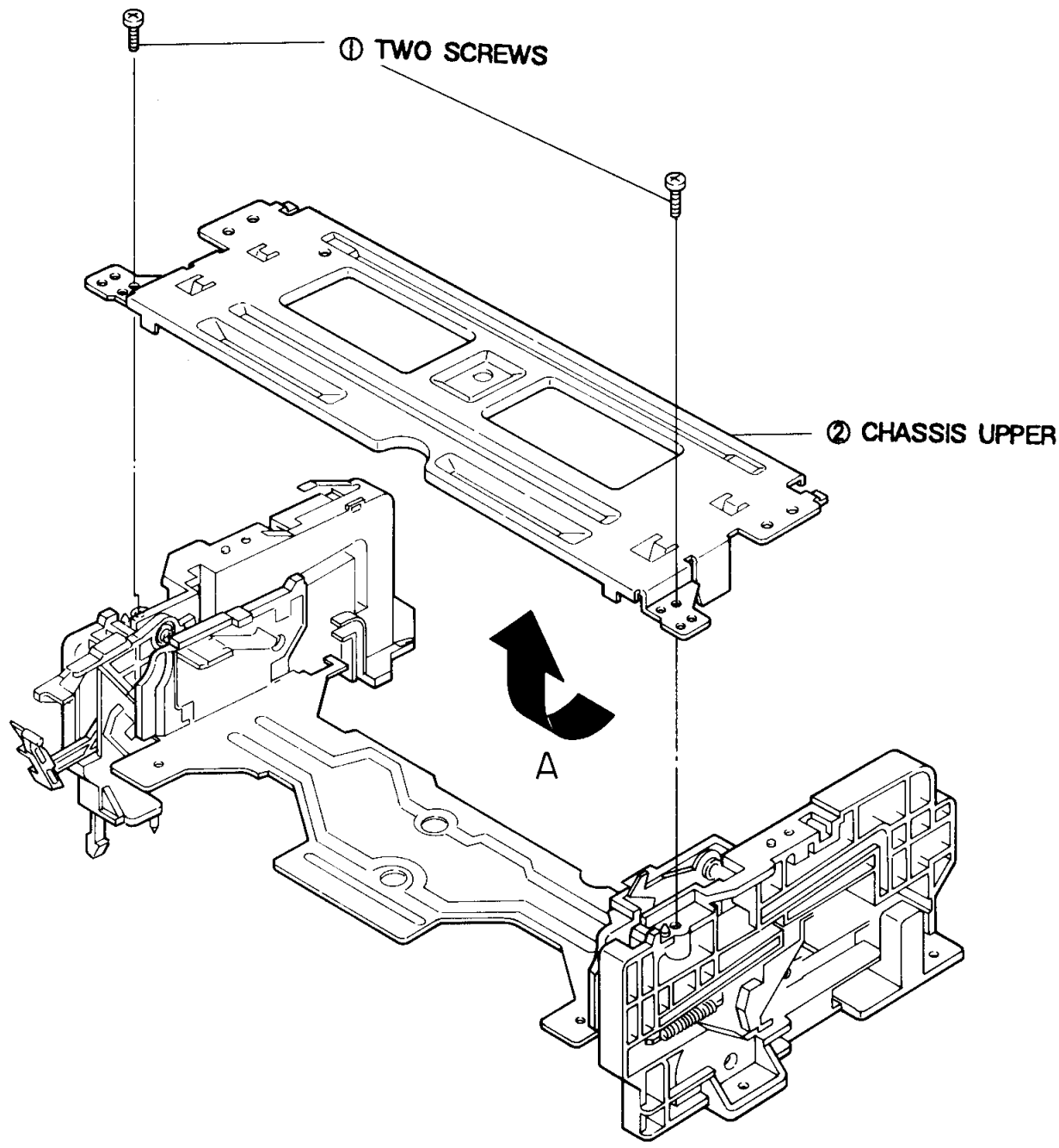

Fig. 14 Upper Chassis Removal

2-6-4. Holder Cassette Ass'y & Chassis Side L/R Removal

1) Lift the holder cassette ① in the direction of arrow "A" (Refer to Fig. A).

2) Remove the chassis side "L" ② & "R" ③ from shaft arm ass'y ④ in the direction of arrows "B", "C" (Refer to Fig. B).

NOTE : If you operate the deck when the holder cassette ass'y is removed, the shaft arm "R" and the slide damper are not returned to their original position. If this happens by accident, push the slide damper of chassis side "R" in the direction of arrow "D", and return the slide damper in the reverse direction of arrow "D" when the shaft arm ass'y is in eject mode.

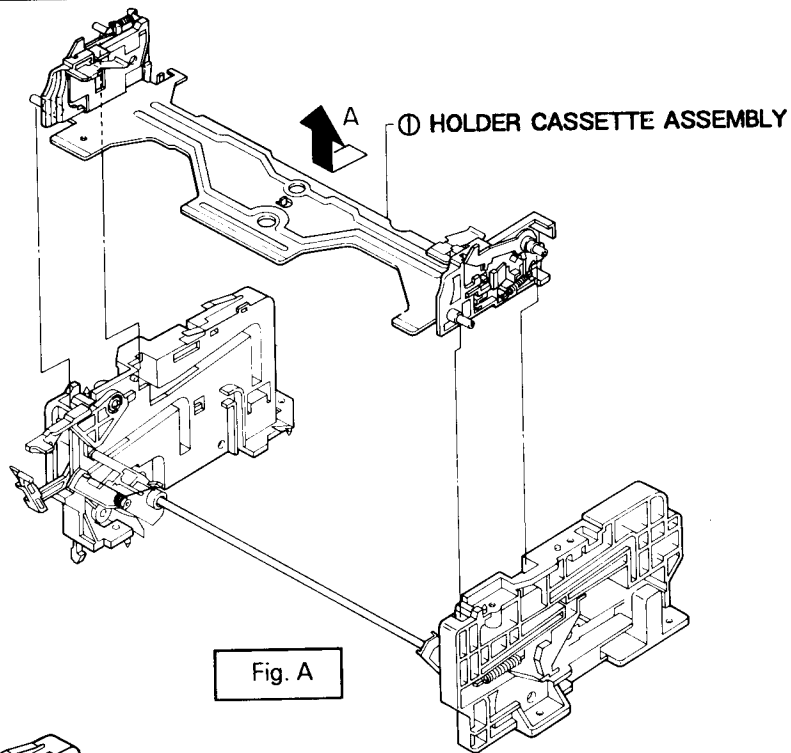

Fig. A

(REASSEMBLY OF CHASSIS
SIDE "R" & SHAFT ARM "R")

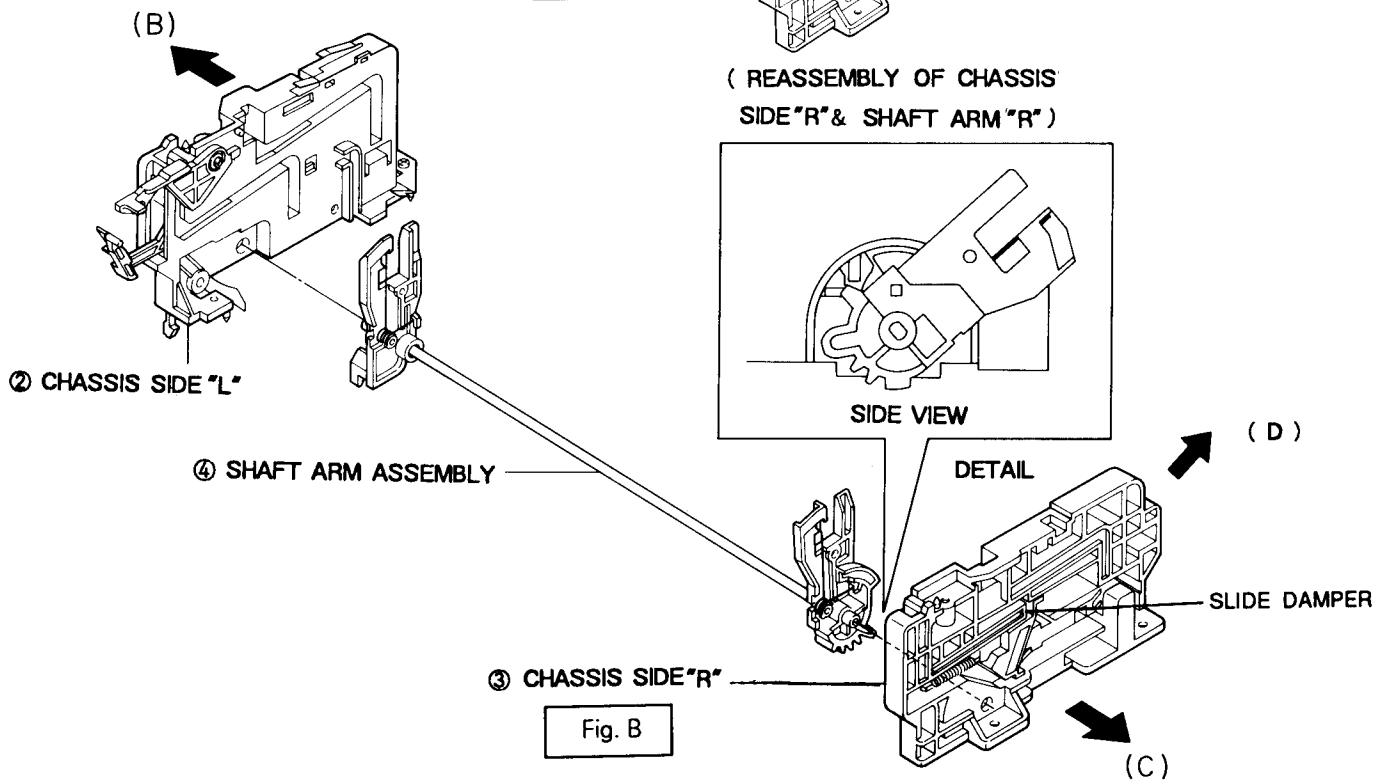

Fig. B

Fig. 15 Holder Cassette Ass'y & Chassis Side L/R Removal

2-6-5. Chassis Side "R" Parts Locations

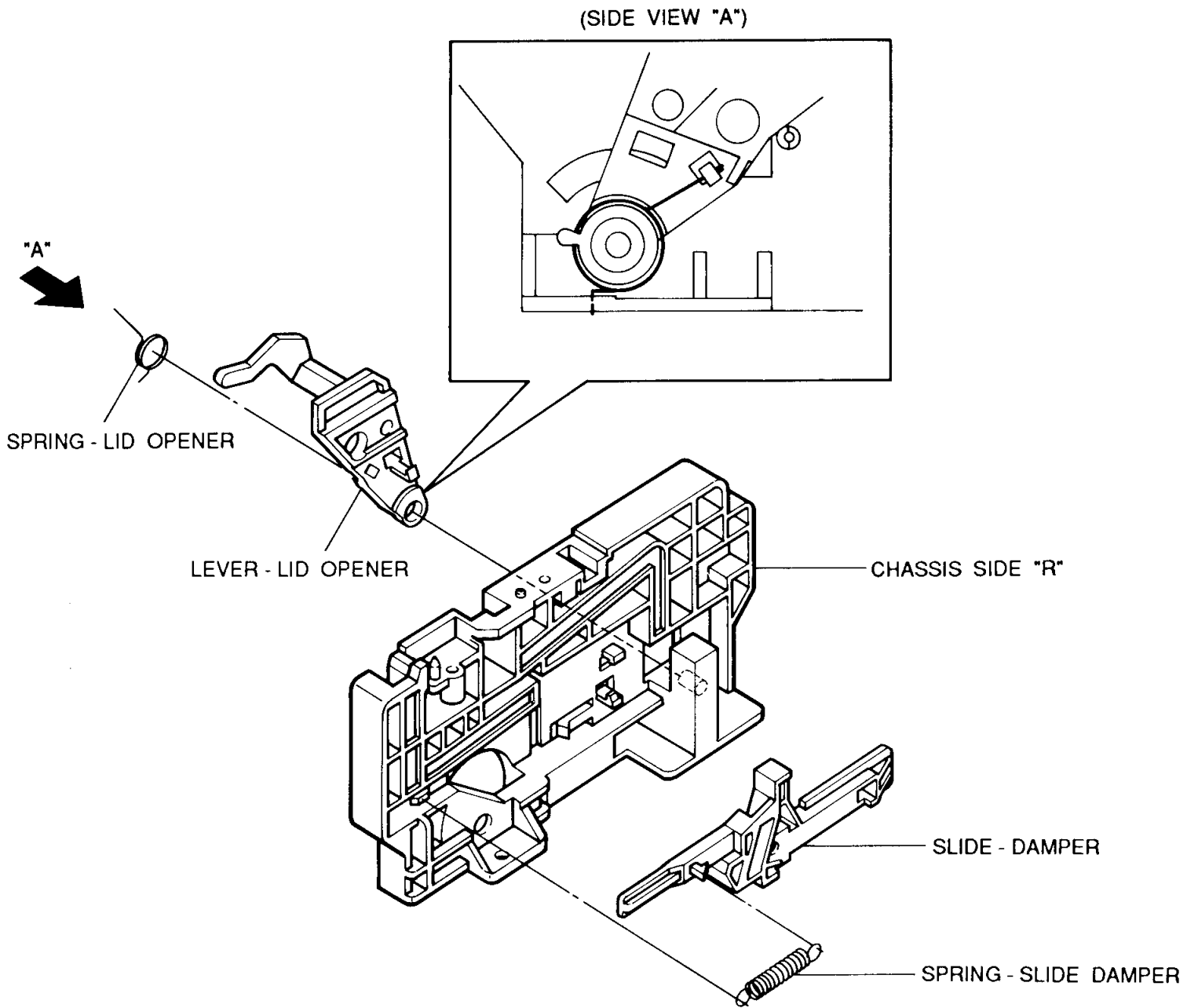

Fig. 16 Chassis Side "R" Parts Locations

2-6-6. Slide Damper Removal

- 1) Remove the spring slide damper ①.
- 2) Push the stopper ③ of the chassis side "R" ④. Move the slide damper ② in the direction of arrow.
- 3) Align the slide damper ② with the chassis side tab (as shown detail drawing).
- 4) Lift the slide damper ② to remove.

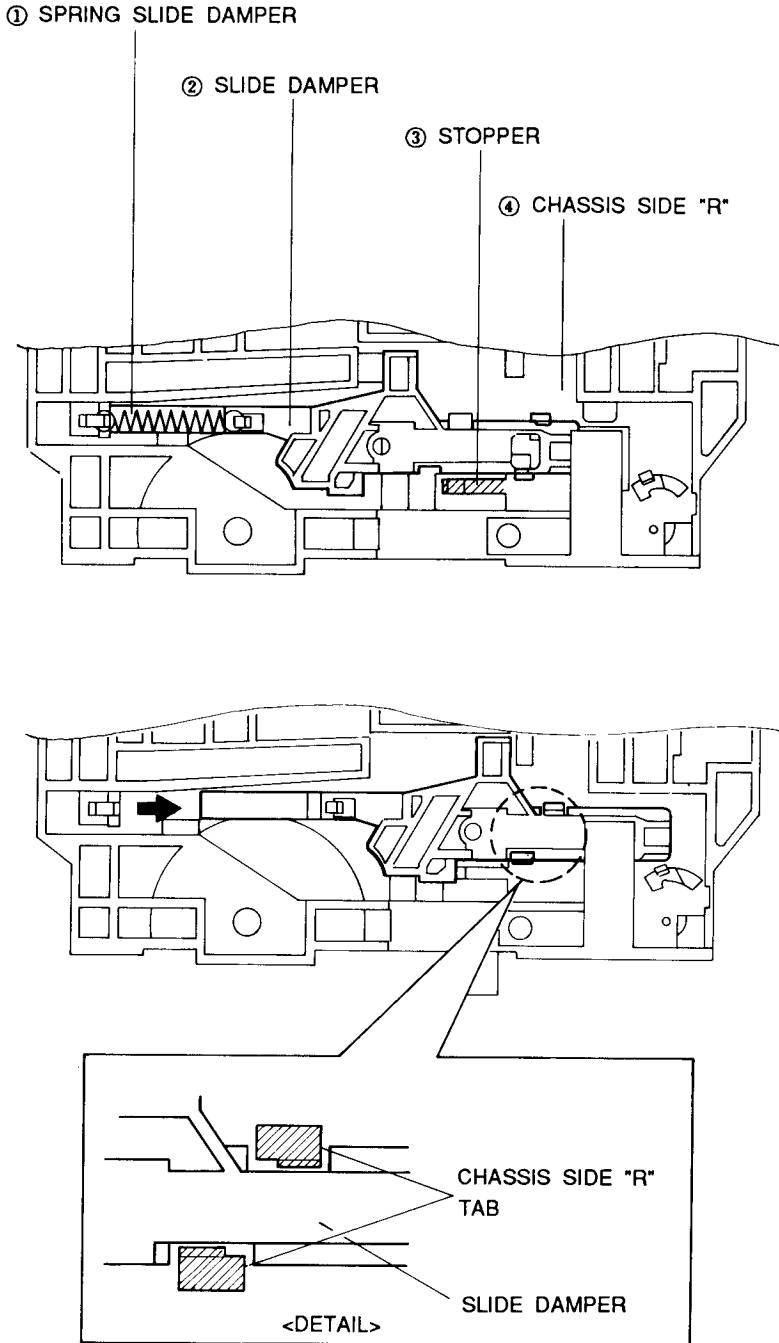

Fig. 17 Slide Damper Removal

2-7. Cylinder Ass'y

2-7-1. Exploded View of Cylinder Ass'y

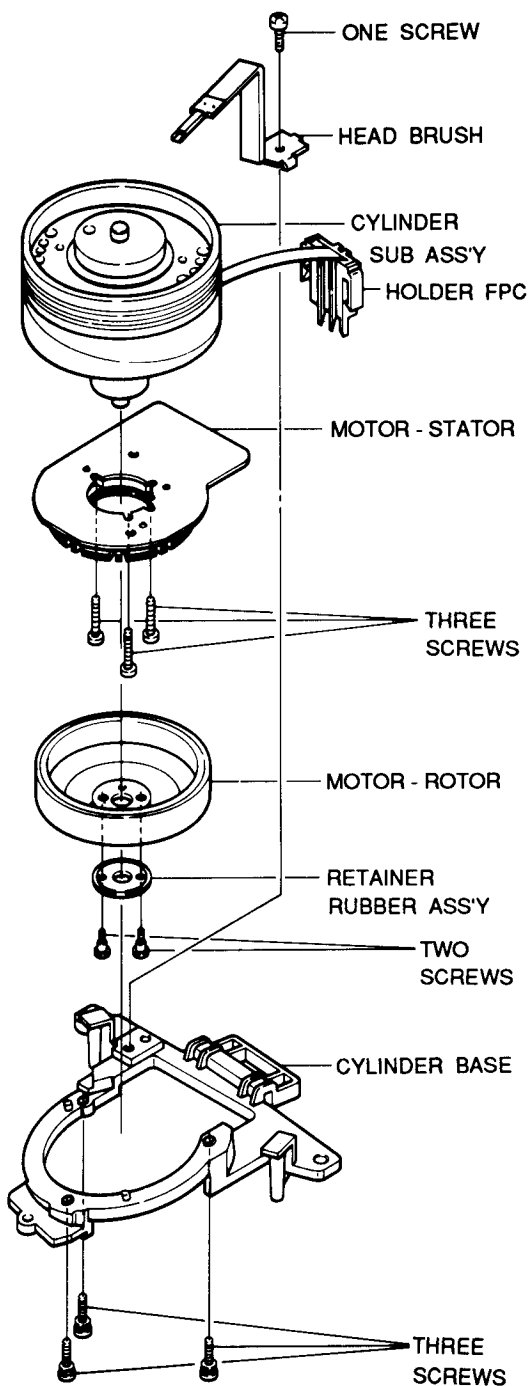

Fig. 18 Exploded View of Cylinder Ass'y

2-7-2. Stopper Tape

[1] Stopper Tape Removal

(Only for deck : DX5-R, Refer to Fig. A)

- 1) Release one(1) tab ① in the direction of arrow "A".
(Refer to detail drawing)
- 2) Lift the stopper tape ② in the direction of arrow "B".

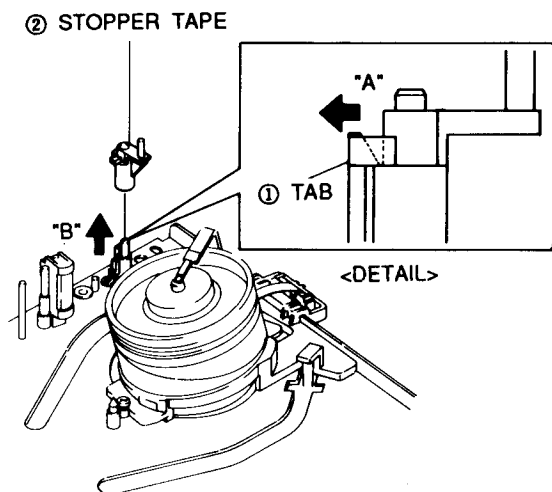

Fig. A

Fig. 19 Stopper Tape Removal

2-7-3. Cylinder Ass'y Removal from Main Base

- 1) Remove three(3) screws ① holding the main base and the cylinder ass'y.
- 2) Lift the cylinder ass'y ② in the direction of arrow.

NOTE : Do not touch the video heads during removal or installation.

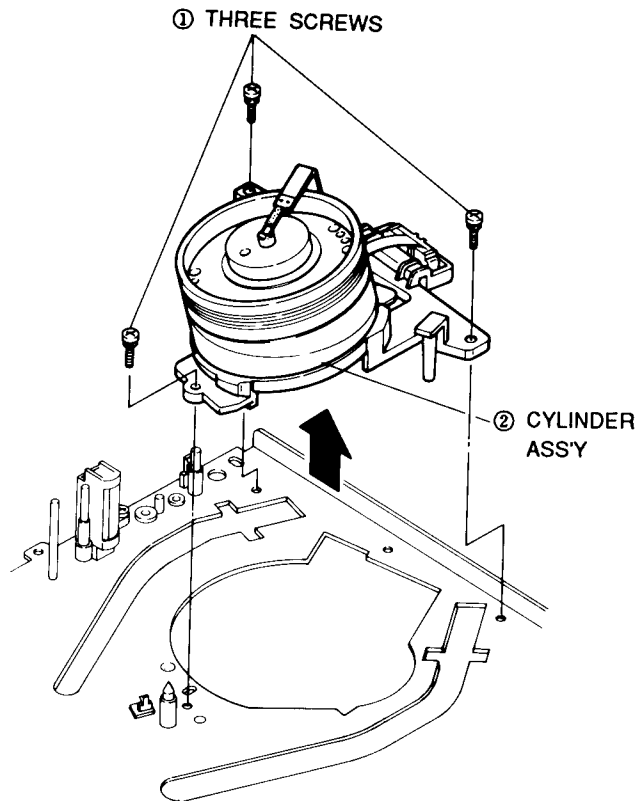

Fig. 20 Cylinder Ass'y Removal from Main Base

2-7-4. Head Brush & Holder FPC Removal

- 1) Remove one(1) screw ① and then lift the head brush ②.
- 2) Release the holder FPC tab holding the cylinder base ④ in the direction of arrow. (Refer to detail drawing)
- 3) Disconnect the holder FPC ③ from the cylinder base ④.

NOTE : When disconnecting the holder FPC ③ from the cylinder base ④: Take care not to disconnect the FPC cable from the holder FPC (The FPC cable is very short.).

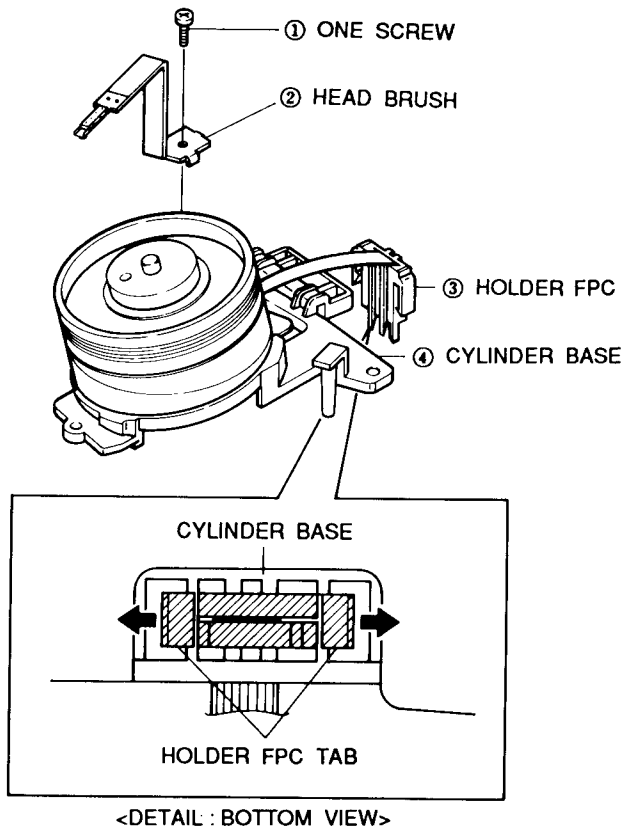

Fig. 21 Head Brush & Holder FPC Removal

2-7-5. Cylinder Ass'y Removal from Cylinder Base

- 1) Remove three(3) screws ① from the cylinder base ②.
- 2) Lift the cylinder ass'y ③ from the cylinder base ② in the direction of arrow.

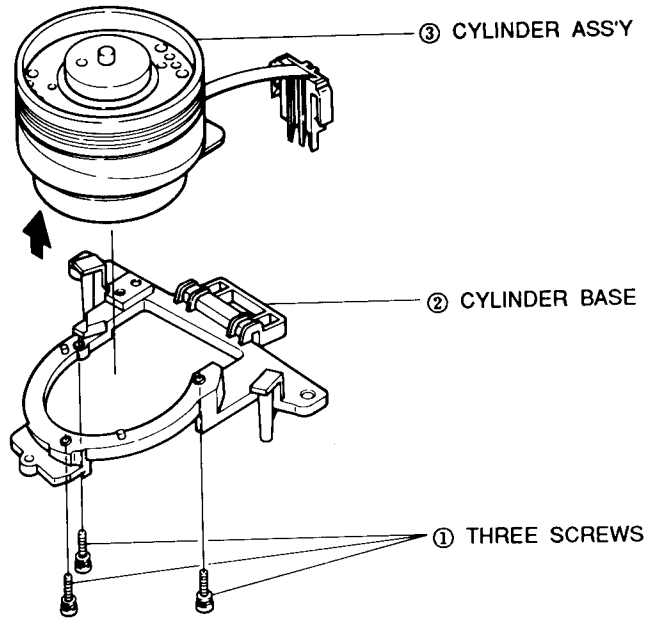

Fig. 22 Cylinder Ass'y Removal from Cylinder Base

2-7-6. Motor Rotor Removal

- 1) Remove two(2) screws ①.
- 2) Lift the retainer lever ass'y ② and the motor rotor ③.

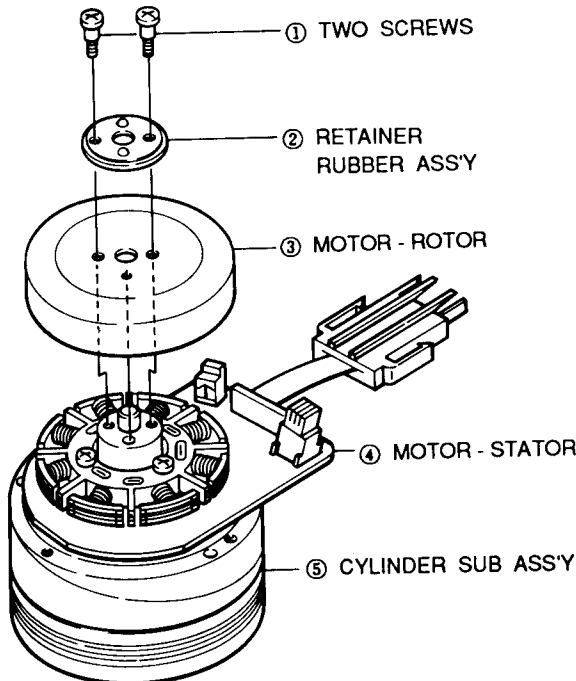

Fig. 23 Motor Rotor Removal

2-7-7. Motor Rotor & Cylinder Sub Ass'y

- 1) Make sure that phase matching holes of the motor rotor & the cylinder sub ass'y are aligned correctly as shown in Fig. 16 . (Refer to phase matching hole)
- 2) Reinstall the retainer lever ass'y ② and secure with two(2) screws.

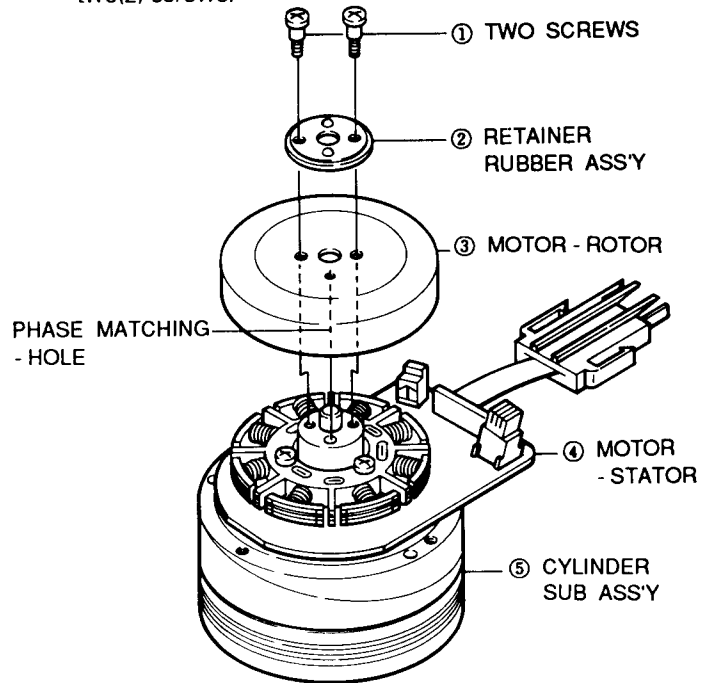

Fig. 24 Assembly of Motor Rotor & Cylinder Sub Ass'y

2-7-8. Motor Stator Removal

- 1) Remove three(3) screws ①.
- 2) Remove the motor stator ② from the cylinder sub ass'y ③.

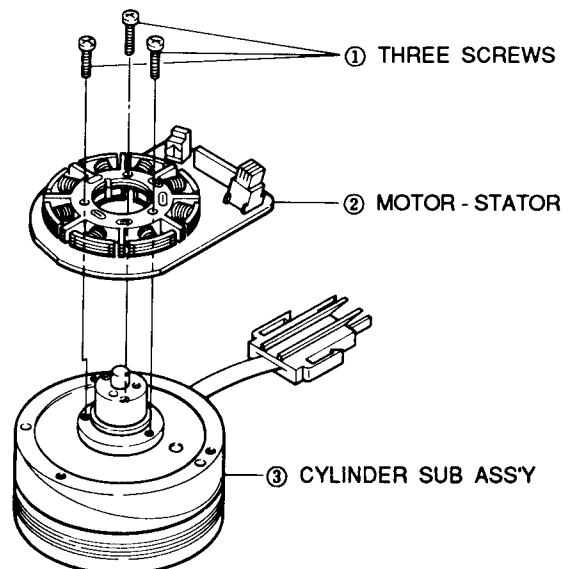

Fig. 25 Motor Stator Removal

2-7-9. Motor Stator & Cylinder Sub Ass'y

- 1) Reinstall the motor stator ① toward the FPC cable of cylinder sub ass'y ②.
- 2) Secure with three(3) screws. (Refer to Fig. 17)

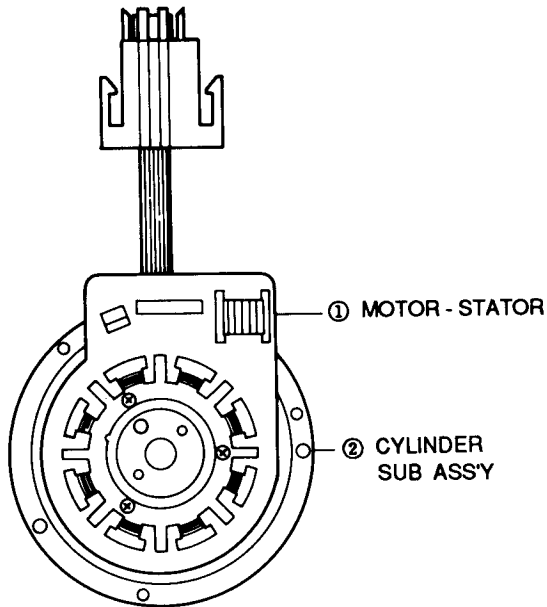

Fig. 26 Assembly of Motor Stator & Cylinder Sub Ass'y

2-8. Main Deck Removal & Reassembly

2-8-1. Slide Rack Housing Removal

- 1) Lift the slide rack housing in the direction of arrow.

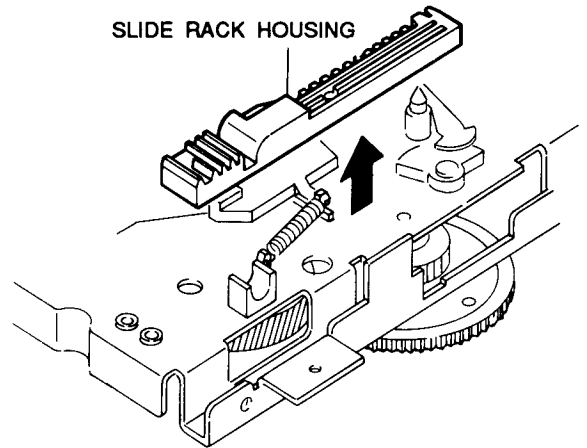

Fig. 27 Slide Rack Housing Removal

2-8-2. Assembly of Slide Rack Housing & Gear Master

- 1) Confirm that the hole of gear master ① and the hole "A" of main base are aligned correctly. (Eject mode)
- 2) Align the slot #1 of gear master ① with the tooth #1 of slide rack housing. (Refer to timing point)

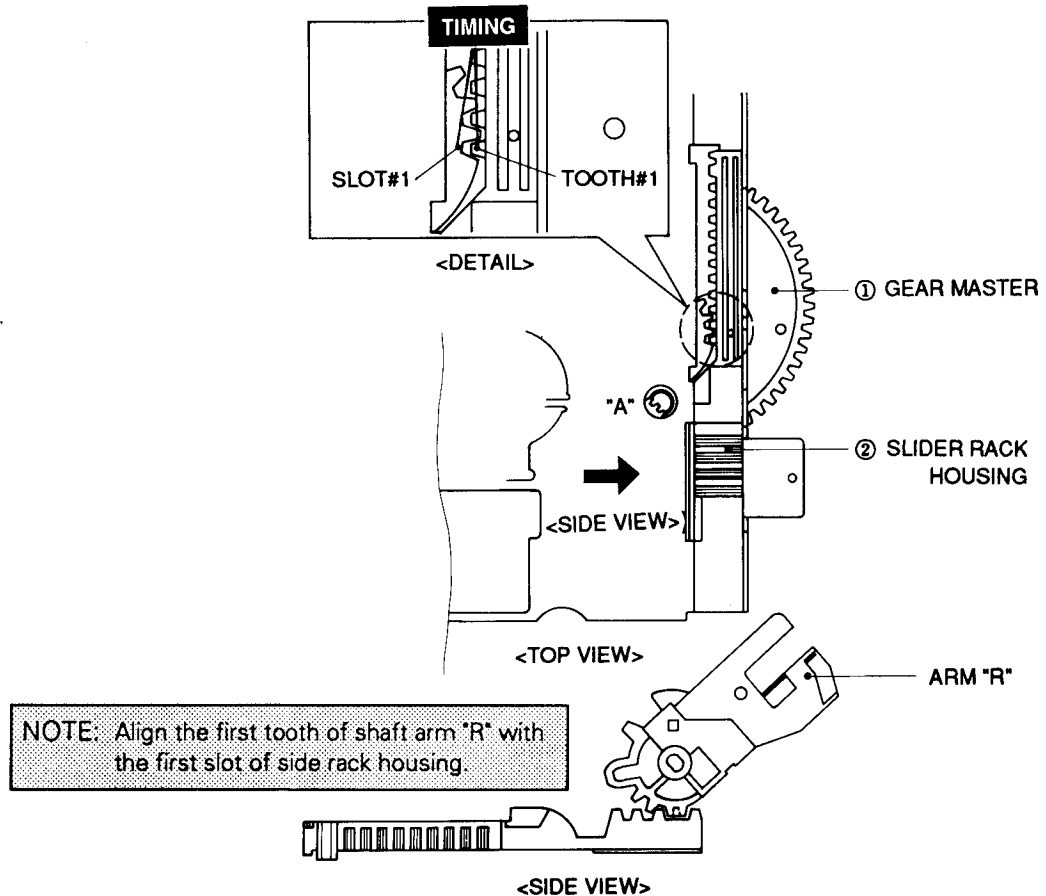
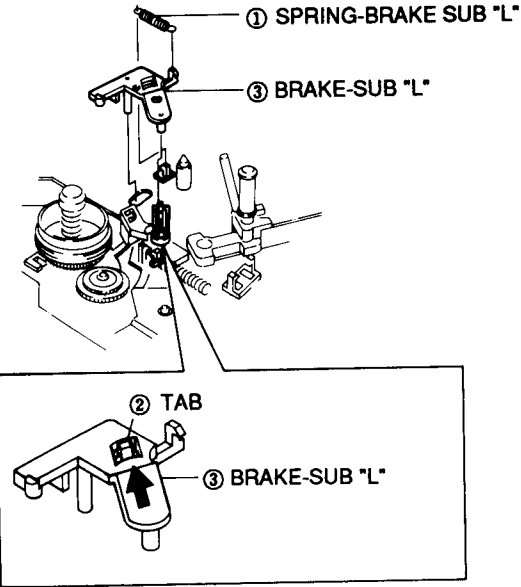

Fig. 28 Assembly of Slide Rack Housing & Gear Master

2-8-3. Brake Sub "L" Removal

- 1) Remove the spring brake sub "L" ①.
- 2) Release the tab ② in the direction of arrow.
(Refer to detail drawing)
- 3) Lift the brake sub "L" ③.



<DETAIL>

Fig. 29 Brake Sub "L" Removal

2-8-4. Arm Tension Full Ass'y Removal

- 1) Remove the spring tension ①.
- 2) Release the tab ② in the direction of arrow.
(Refer to detail drawing)
- 3) Lift the arm tension full ass'y ③.

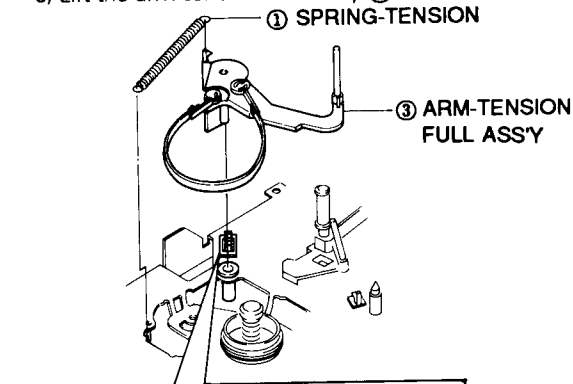

<DETAIL>

Fig. 30 Arm Tension Full Ass'y Removal

2-8-5. Reel Disk "L" Ass'y & Gear Relay "S" Ass'y Removal

- 1) Release the tab ① in the direction of arrow.
(Refer to detail drawing)
- 2) Lift the reel disk "L" ass'y ②.
- 3) Remove the washer plain ③.
- 4) Remove the washer slit ④.
- 5) Lift the gear relay "S" ass'y ⑤.

NOTE : When reinstalling, be sure to install the reel disk "L" ass'y ② after installing the washer plain ③.

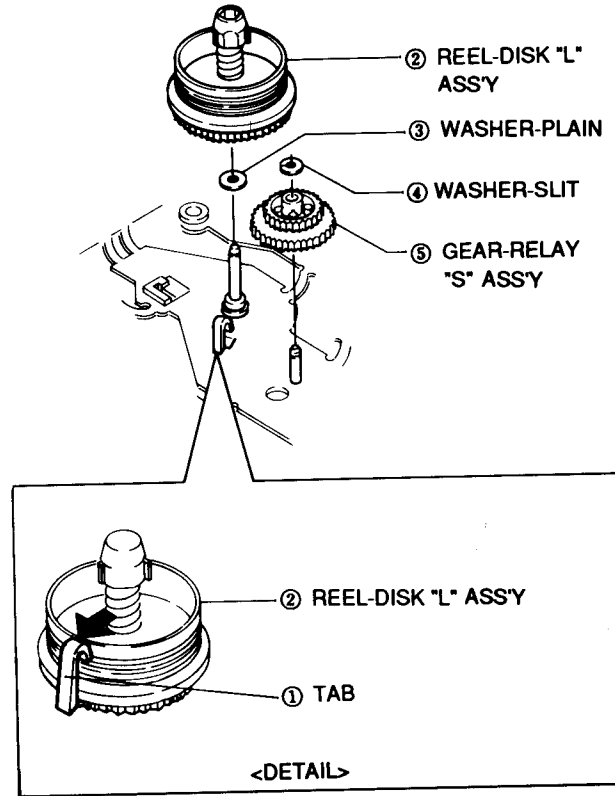

<DETAIL>

Fig. 31 Reel Disk "L" Ass'y & Gear Relay "S" Ass'y Removal

2-8-6. Brake Sub "R" Ass'y Removal

- 1) Remove the spring brake sub "R" ①.
- 2) Release the tab ② in the direction of arrow.
(Refer to detail drawing)
- 3) Lift the brake sub "R" ass'y ③.

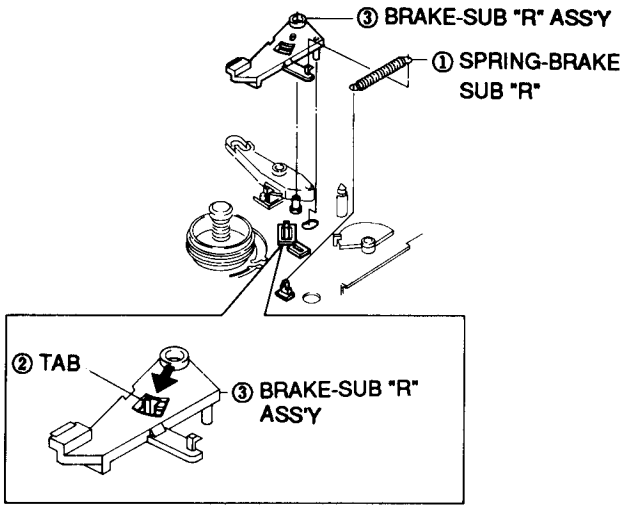

Fig. 32 Brake Sub "R" Ass'y Removal

2-8-7. Reel Disk "R" Ass'y & Gear Relay "T" Removal

- 1) Release the tab ① in the direction of arrow.
(Refer to detail drawing)
- 2) Lift the reel disk "R" ass'y ②.
- 3) Remove the washer plain ③.
- 4) Remove the washer slit ④.
- 5) Lift the gear relay "T" ass'y ⑤.

NOTE : When reinstalling, be sure to install the reel disk "R" ass'y ② after installing the washer plain ③.

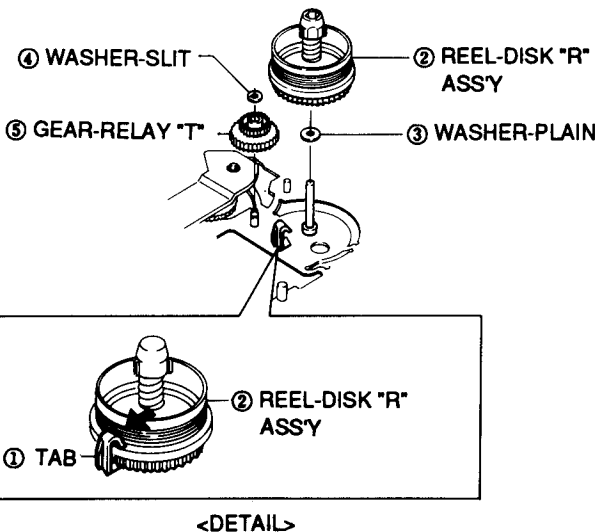

Fig. 33 Reel Disk "R" Ass'y & Gear Relay "T" Removal

2-8-8. Brake Main "L", "R" Ass'y Removal

- 1) Remove the spring brake main ①.
- 2) Release the tab ② in the direction of arrow "A".
(Refer to detail drawing "A")
- 3) Lift the brake main "L" ③.
- 4) Release the tab ④ in the direction of arrow "B".
(Refer to detail drawing "B")
- 5) Lift the brake main "R" ⑤.

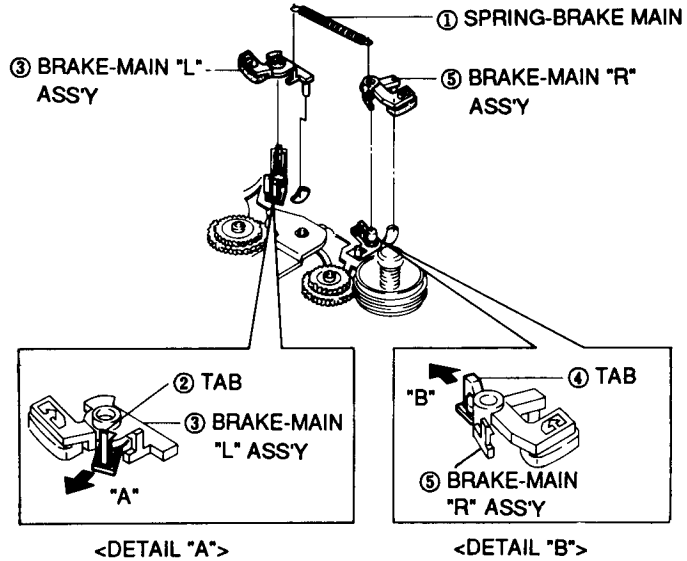

Fig. 34 Brake Main "L", "R" Ass'y Removal

2-8-9. Idler Ass'y Removal

- 1) Remove the washer slit ①.
- 2) Lift the idler ass'y ②.

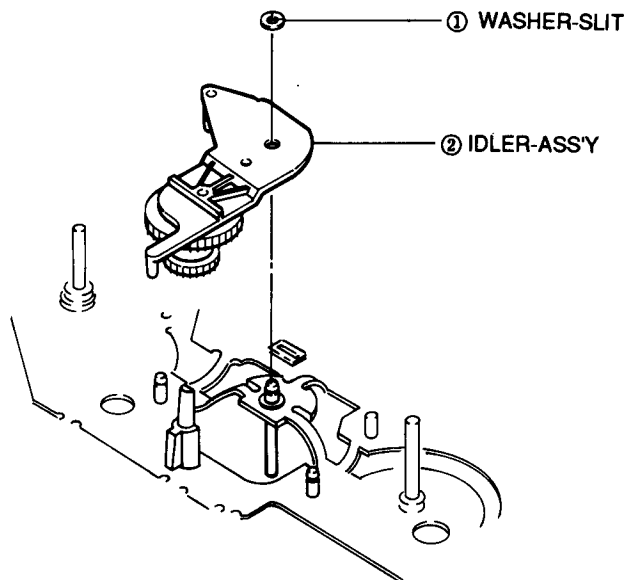

Fig. 35 Idler Ass'y Removal

2-8-10. Unit Pinch Roller Ass'y Removal

- 1) Remove the washer slit ①.
- 2) Lift the unit pinch roller ②.
- 3) Lift the spring arm pinch ③.

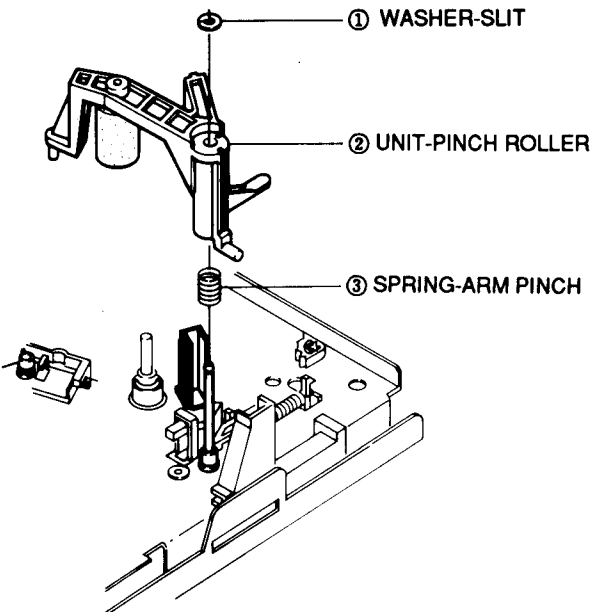

Fig. 36 Unit Pinch Roller Ass'y Removal

2-8-11. Assembly of Unit Pinch Roller

- 1) Install the unit pinch roller as shown in Fig. 29. (Refer to A, B)

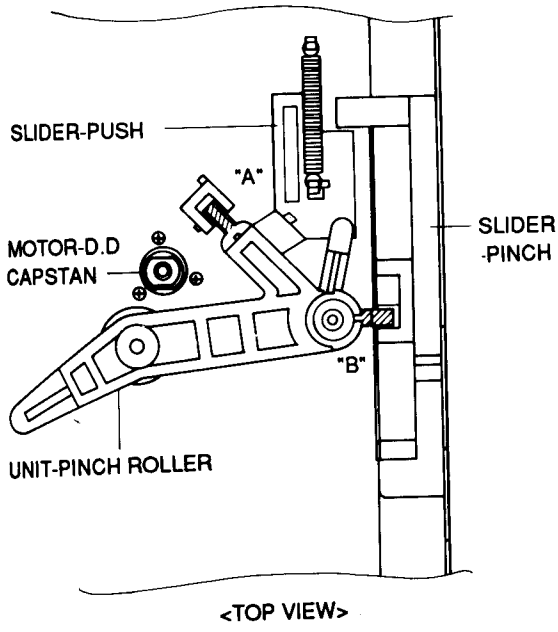

Fig. 37 Assembly of Unit Pinch Roller

2-8-12. Exploded View of Lever Pinch Comp Ass'y, Lever Pinch Cam, Arm Review Ass'y & Lever Review Ass'y

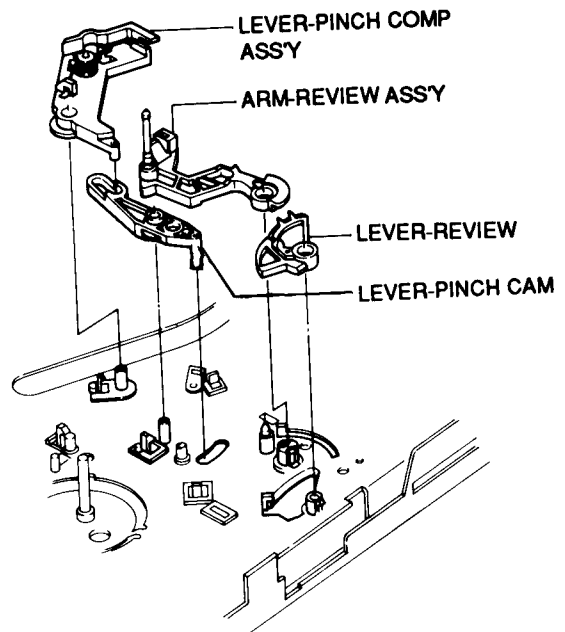

Fig. 38 Exploded View of Lever Pinch Comp Ass'y, Lever Pinch Cam, Arm Review Ass'y & Lever Review Ass'y

2-8-13. Lever Pinch Comp Ass'y Removal

- 1) Release the tab ① in the direction of arrow. (Refer to detail drawing)
- 2) Lift the lever pinch comp ass'y ②.

NOTE : Don't touch the lever pinch comp ass'y ① to audio head base during removal.

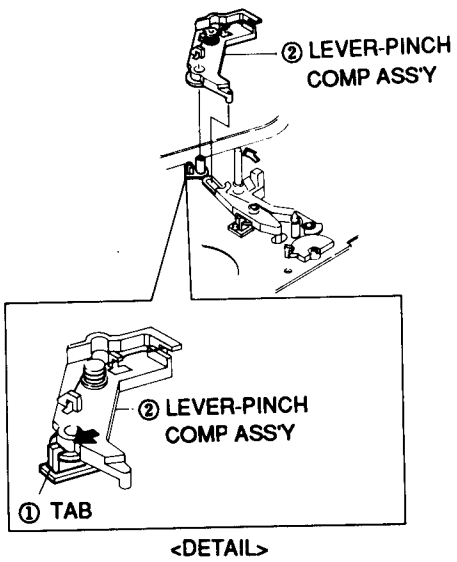

Fig. 39 Lever Pinch Comp Ass'y Removal

2-8-14. Lever Pinch Cam Removal

- 1) Release the tab ① in the direction of arrow.
(Refer to detail drawing)
- 2) Lift the lever pinch cam ②.

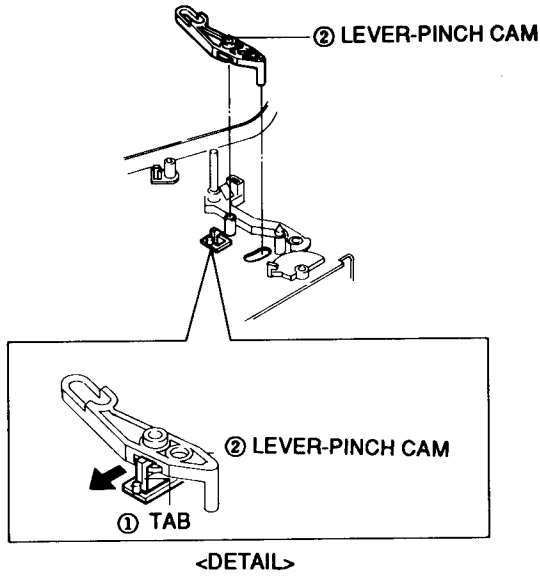
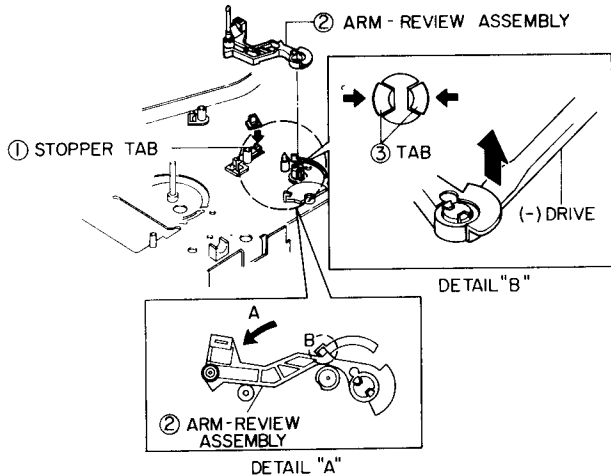

Fig. 40 Lever Pinch Cam Removal

2-8-15. Arm Review Ass'y Removal

- 1) Push the stopper tab ① in the direction of arrow.
- 2) Pull the arm review ass'y ② in the direction of arrow "A" and then confirm "B". (Refer to detail drawing "A")
- 3) Release the tab ③ in the direction of arrow and then lift the arm review ass'y ②.

NOTE : Take extreme care not to damage when removing the arm review ass'y ②.
(B part of detail drawing A)



NOTE: Be sure to remove the arm review assy with using the(-)driver

Fig. 41 Arm Review Ass'y Removal

2-8-16. Lever Review Removal

- 1) Release the tab ① in the direction of arrow.
(Refer to detail drawing)
- 2) Lift the lever review ②.

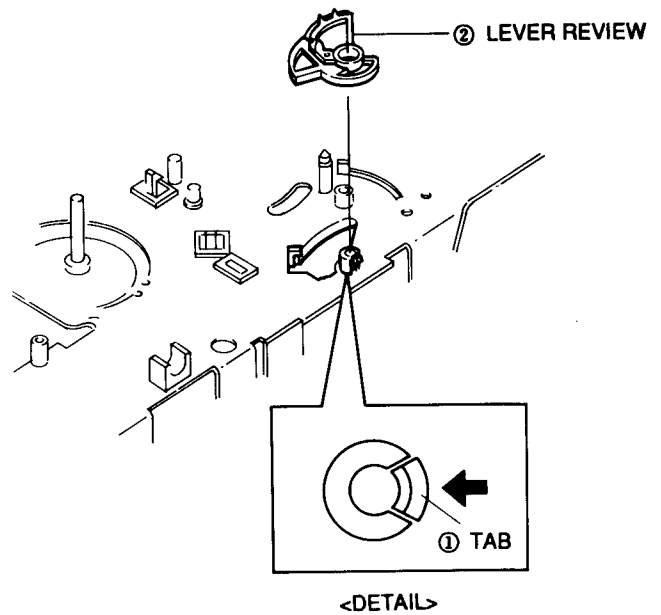

Fig. 42 Lever Review Removal

2-8-17. Belt Capstan Removal

- 1) Remove the belt capstan ①.

NOTE : Take extreme care not to touch the grease when removing or reinstalling.

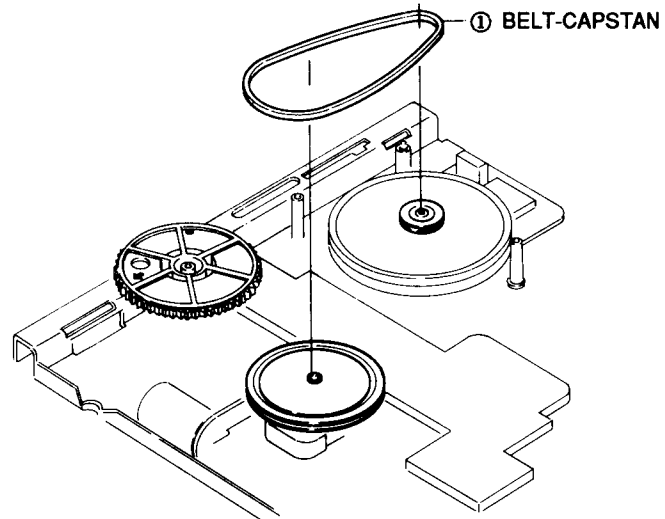

Fig. 43 Belt Capstan Removal

2-8-18. Brake Capstan Ass'y Removal

- 1) Remove the spring brake capstan ①.
- 2) Release the tab ② in the direction of arrow.
(Refer to detail drawing)
- 3) Lift the brake capstan ass'y ③.

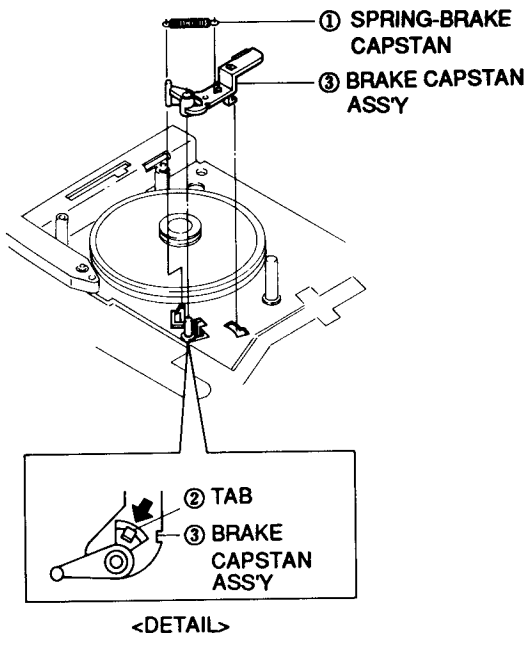
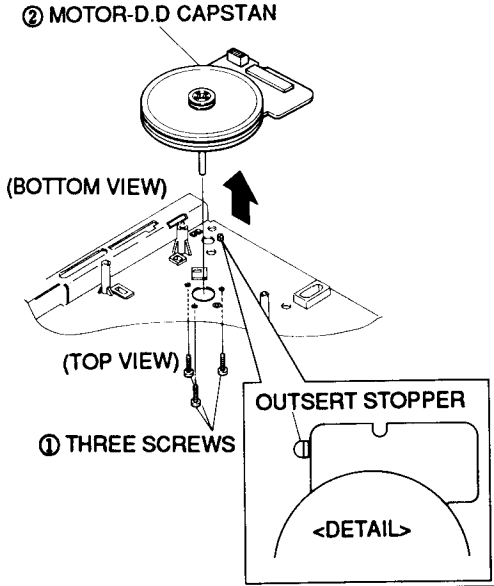

Fig. 44 Brake Capstan Ass'y Removal

2-8-19. Motor D.D Capstan Removal

- 1) Remove three(3) screws ①. (Top view)
- 2) Lift the motor D.D capstan ② in the direction of arrow.
(Bottom view)



NOTE: When reassembling motor - D.D capstan②, align side of capstan wafer with stopper as shown figure.

Fig. 45 Motor D.D Capstan Removal

2-8-20. Clutch Ass'y Removal

- 1) Remove the washer slit ①.
- 2) Lift the clutch ass'y ②.
- 3) Remove the washer plain ③.

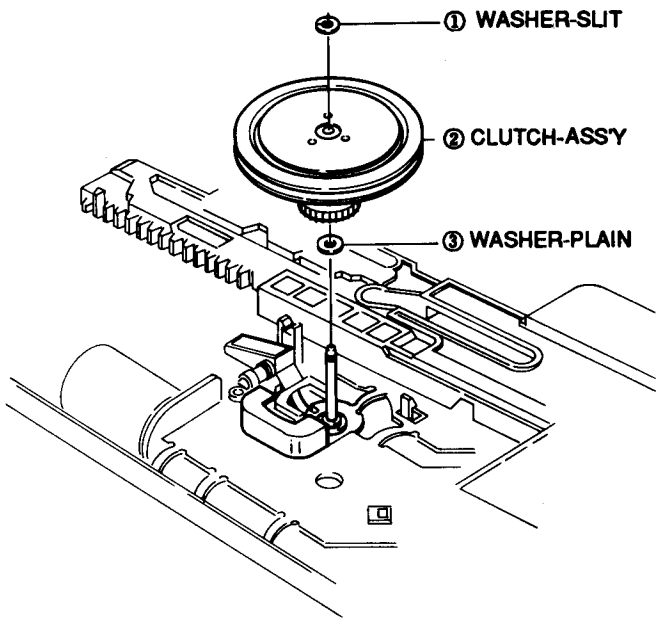

Fig. 46 Clutch Ass'y Removal

2-8-21. Gear Master Removal

- 1) Remove the washer slit ①.
- 2) Lift the gear master ②.

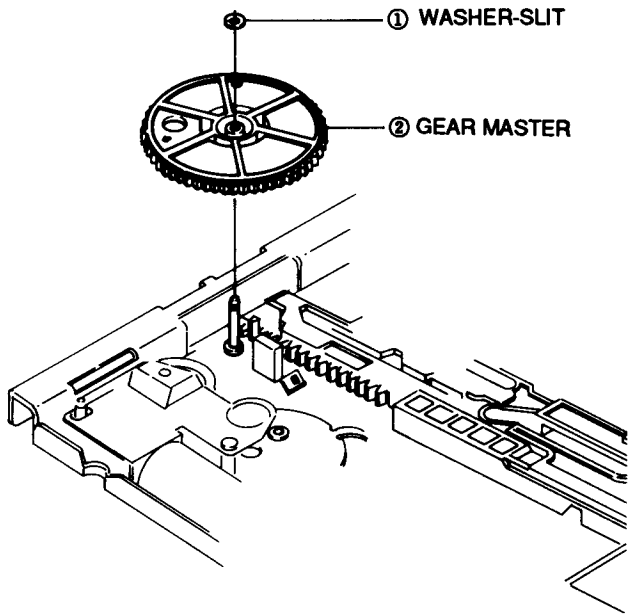

Fig. 47 Gear Master Removal

2-8-22. Assembly of Gear Master

- 1) When reinstalling, be sure to align the arrow mark of gear master ① with gear home of gear worm wheel ②. (Refer to timing point)

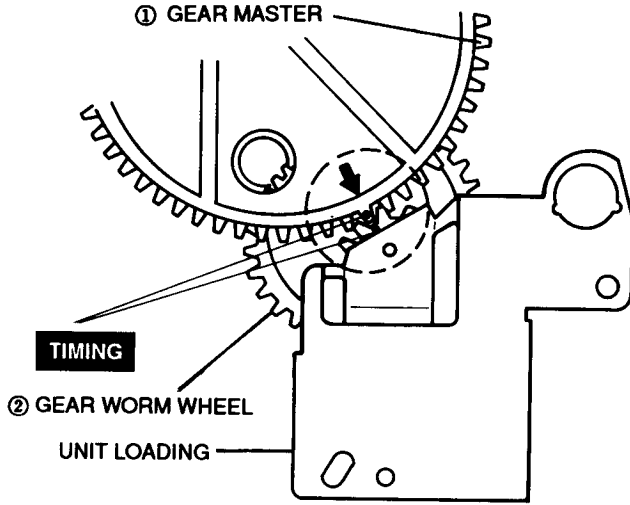

Fig. 48 Assembly of Gear Master

2-8-23. Unit Loading Removal

- 1) Remove two(2) screws ①.
- 2) Lift the unit loading ② in the direction of arrow.

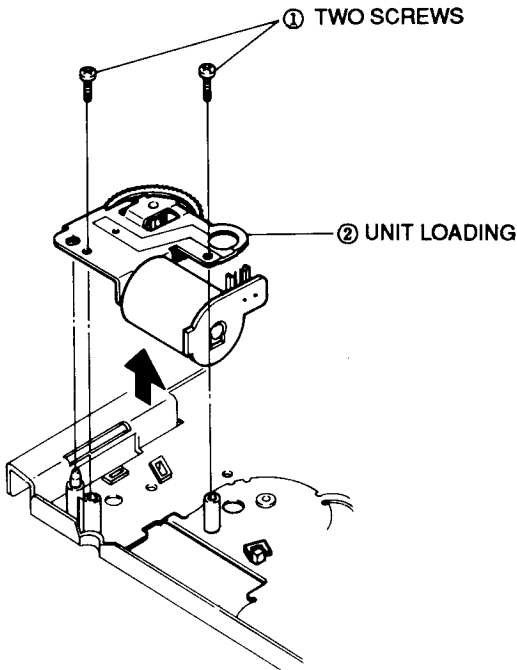

Fig. 49 Unit Loading Removal

2-8-24. Lever Slide Pinch Removal

- 1) Remove the washer slit ①.
- 2) Lift the lever slide pinch ②.

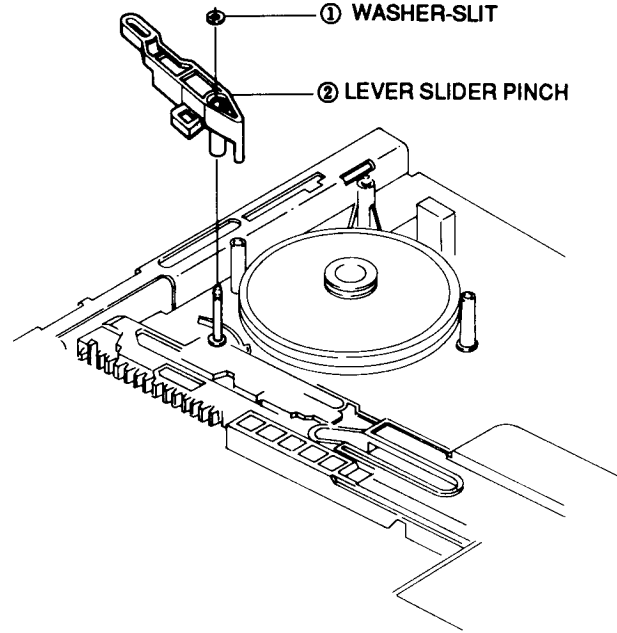

Fig. 50 Lever Slide Pinch Removal

2-8-25. Assembly of Lever Slide Pinch

- 1) Pull the slide pinch ① to the end in the direction of arrow.
- 2) Insert the slide pinch ① into the hole of lever slide pinch ②. (Refer to "A" part)

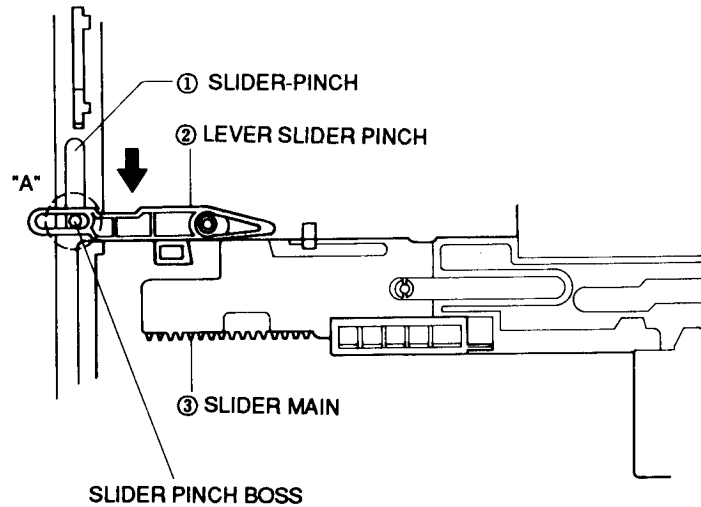

Fig. 51 Assembly of Lever Slide Pinch

2-8-26. Slide Main Removal

- 1) Remove the washer slit ①.
- 2) Release three(3) tabs ②, ③, ④ in the direction of arrow.
- 3) Lift the slide main ⑤.

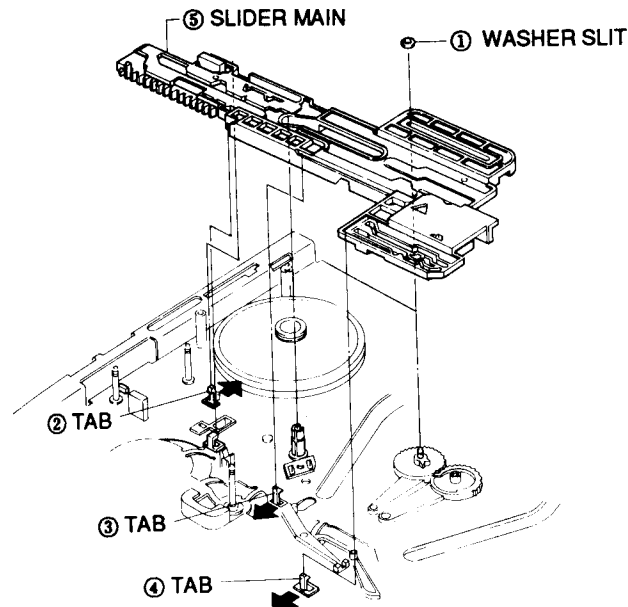
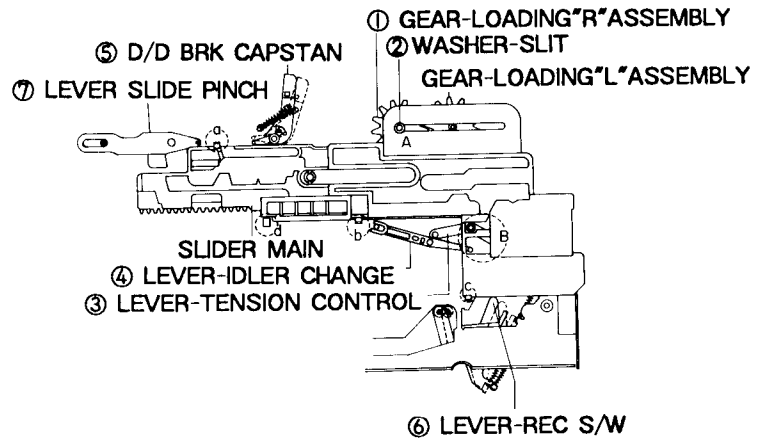

Fig. 52 Slide Main Removal

2-8-27. Assembly of Slide Main

- 1) Install the shaft of gear loading "R" ass'y into the left of the main slide hole and secure with the washer slit ②. (Refer to "A")
- 2) Insert the lever tension control ③ and the lever idler change ④ into the slide main hole. (Refer to "B")
- 3) After confirming the above items 1), 2) install the slide main and secure with tabs (a, b, c).

NOTE: Be sure to assemble the side main when the gear loading 1/r assy is in unloading position.



NOTE : Seven parts should be installed into the side main hole.

Fig. 53 Assembly of Slide Main (Bottom view)

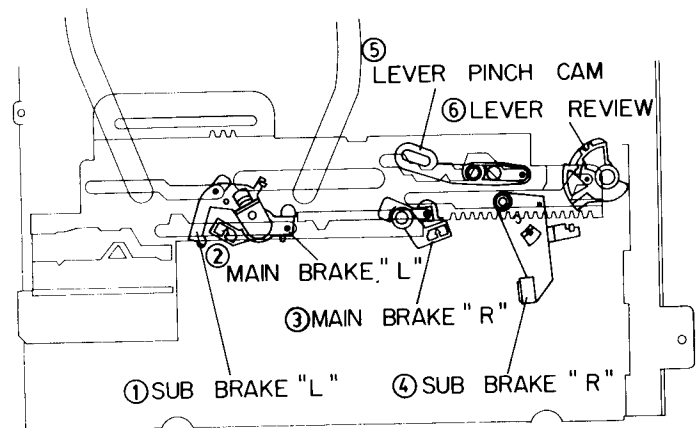

NOTE: Six parts should be installed into the side main hold.

Fig. 54 Assembly of side Main(Top view)

2-8-28. Lever Shift Ass'y Removal

- 1) Hang the spring lever shift ① to the claw of the lever shift ③. (Refer to detail drawings "A", "B")
- 2) Release the tab ② in the direction of arrow.
- 3) Lift the lever shift ③.

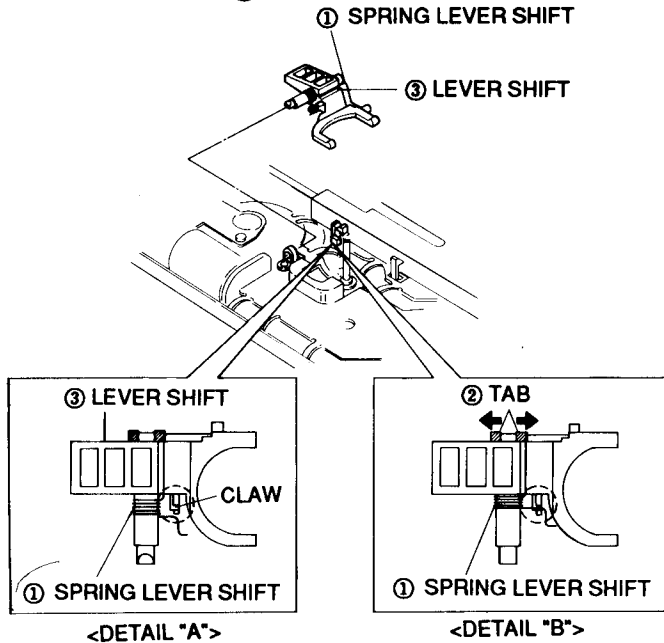

Fig. 55 Lever Shift Ass'y Removal

2-8-29. Lever Idler Change Removal

- 1) Release the tab ① in the direction of arrow. (Refer to detail drawing)
- 2) Lift the lever idler change ②

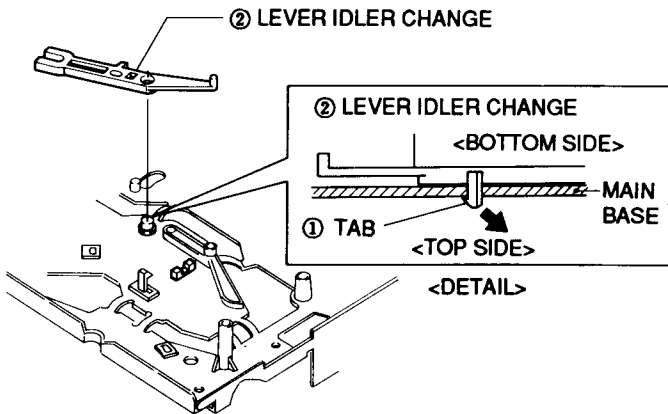

Fig. 56 Lever Idler Change Removal

2-8-30. Gear Loading "L", "R" Ass'y Removal

- 1) Remove the gear loading "R" ass'y ② from the slide guide roller "T" ③ by pushing the spring loading "R" ① in the direction of arrow. (Refer to detail drawing "A")
- 2) Remove the gear loading "L" ass'y ⑤ from the slide guide roller "S" ⑥ by pushing the spring loading "L" ④ in the direction of arrow. (Refer to detail drawing "B")
- 3) Lift the gear loading "R" ass'y ②.
- 4) Lift the gear loading "L" ass'y ⑤ by pushing the tab ⑦ of the gear loading "L" ass'y ⑤. (Refer to detail drawing "C")

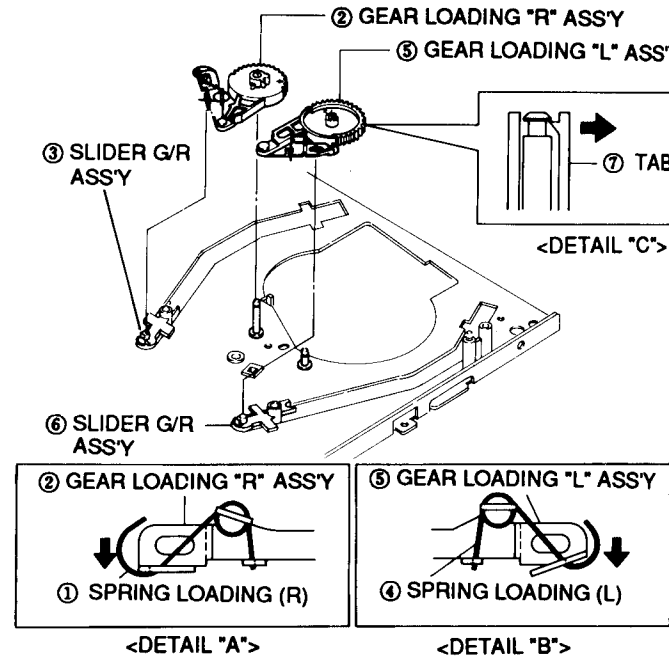

Fig. 57 Gear Loading "L", "R" Ass'y Removal

2-8-31. Gear Loading "L", "R" Ass'y

- 1) When reinstalling, be sure to align two arrows as shown in Fig. 58. (Refer to timing point)

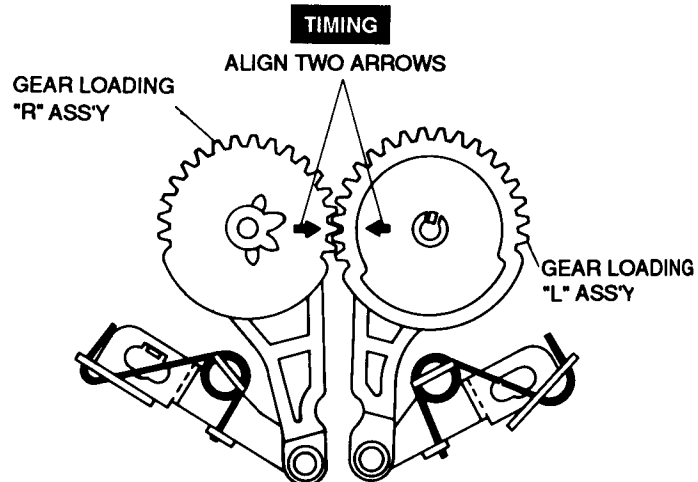

Fig. 58 Assembly of Gear Loading "L", "R" Ass'y

2-8-32. Slide Pinch Removal

- 1) Push the tab ① in the direction of arrow "A".
(Refer to detail drawing)
- 2) Lift the slide pinch ② in the direction of arrow "B".

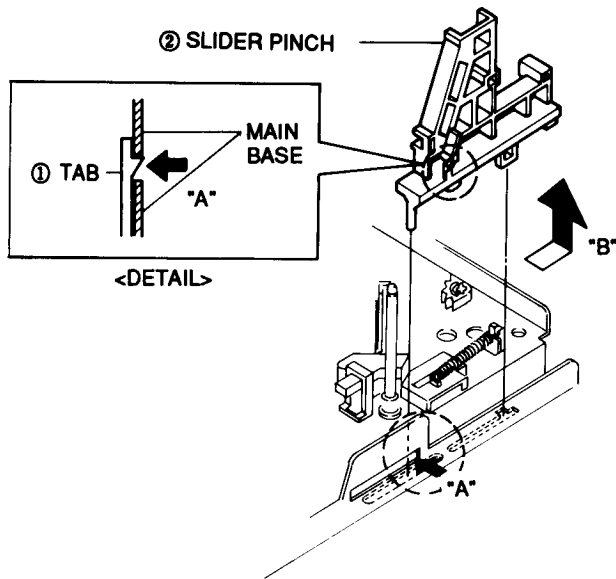

Fig. 59 Slide Pinch Removal

2-8-33. Slide Push Removal

- 1) Remove the spring slide push ①.
- 2) Push the slide push ② in the direction of arrow "A".
- 3) Lift the slide push ② by pushing the tab ③ in the direction of arrow "B". (Refer to detail drawing)

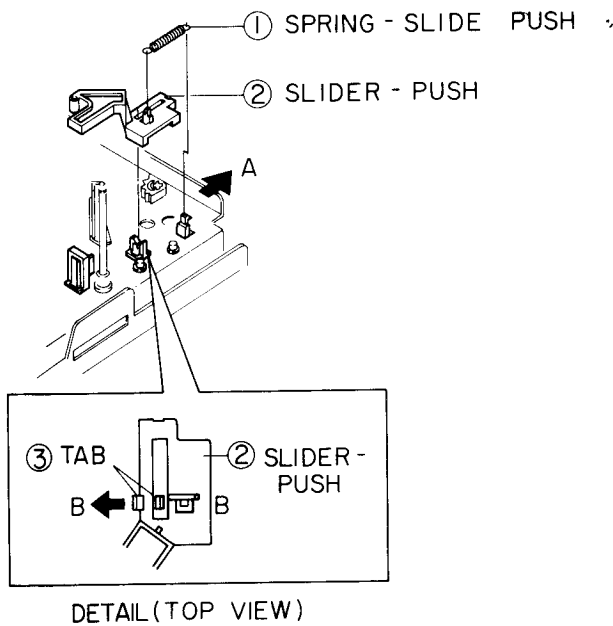

Fig. 60 Slide Push Removal

2-8-34. Prism LED Removal

- 1) Release the tab ① in the direction of arrow.
(Refer to detail drawing)
- 2) Lift the prism LED ②.

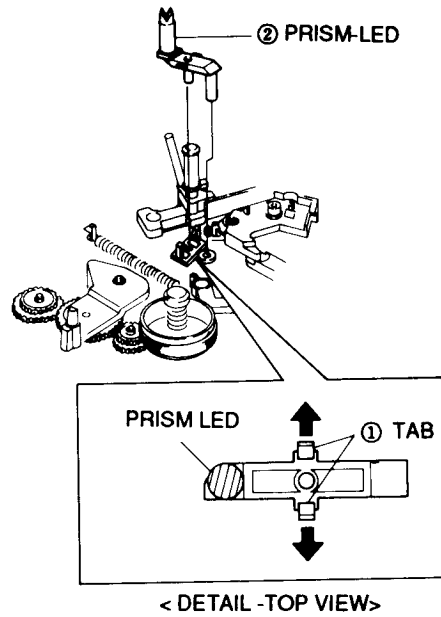

Fig. 61 Prism LED Removal

2-8-35. Lever Record Switch Removal

- 1) Remove the spring record switch ①.
- 2) Release the tab ② in the direction of arrow.
(Refer to detail drawing)
- 3) Lift the lever record switch ③.

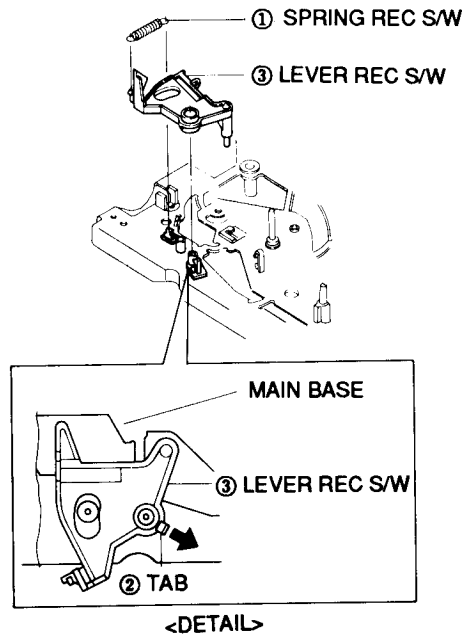

Fig. 62 Lever Record Switch Removal

2-8-36. Full Erase Head Removal

- 1) Remove one(1) screw ①.
- 2) Lift the magnet F/E head ②.

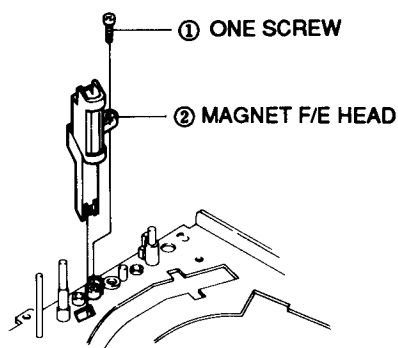

Fig. 63 Full Erase Head Removal

2-8-37. ACE Head Removal & Reassembly

- 1) Release the tab ① holding holder ACE toward arrows.
(Refer to detail drawing "A")
- 2) Remove one(1) screw ②.
- 3) Lift the magnet ACE head ass'y ③.

Assembly : When reinstalling, be sure to align the three teeth of X-Position adjustment gear with the two slot of ACE head base.

NOTE : When adjusting the X-position adjustment gear using (+) driver, do not adjust by force.

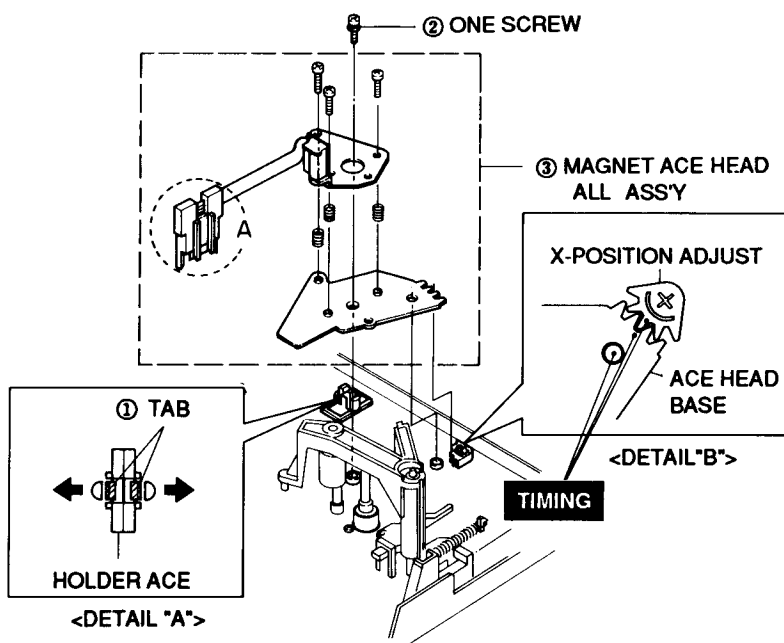

Fig. 64 ACE Head Ass'y Removal & Reassembly

2-8-38. Slide Guide Roller "S", "T" Ass'y Removal

- 1) Remove the cylinder ass'y from the main base.
(Refer to Fig. 19, 20)
- 2) Remove the slide "S", "T" from the gear loading "L", "R" ass'y. (Refer to Fig. 58)
- 3) Move the guide roller "S", "T" ass'y to slot and then lift it to remove. (Refer to arrow)

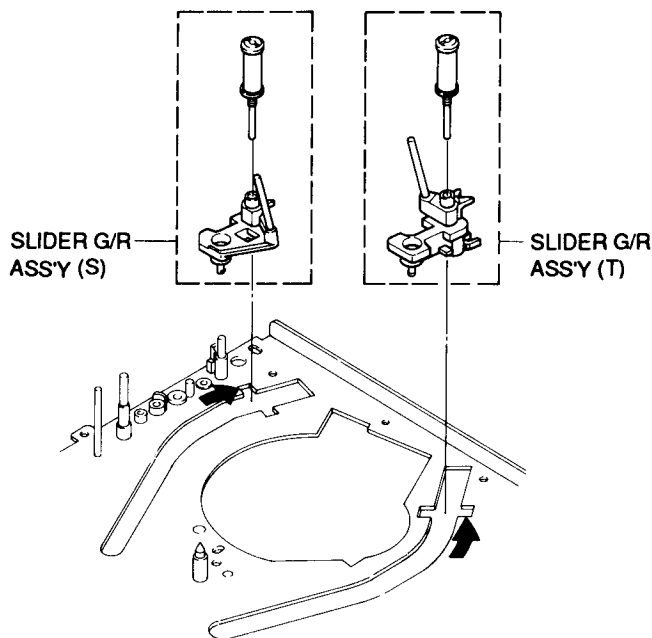

Fig. 65 Slide Guide Roller "S", "T" Ass'y Removal

**2-8-39. Slide Guide Roller "S", "T" Ass'y
(When all parts except the cylinder
assembly are removed.)**

- 1) Push four(4) Lever Locks ① of the housing ass'y Simultaneously. (Refer to Fig. 66)
- 2) Push the holder cassette ass'y ③ toward arrow "B" while turning the gear master ② toward arrow "A". (Refer to Fig. 66)
- 3) Load the gear loading L, R ass'y ④, ⑤ to the middle position of guide rail by turning the gear master ② toward arrow "A". (Refer to Fig. 66, 67)
- 4) Install the slide guide roller S, T ⑥, ⑦ into rail slot and then move it to the position of gear loading L, R ass'y ④, ⑤. (Refer to Fig. 67)
- 5) Turn the gear master ② toward arrow "A". (Eject mode)

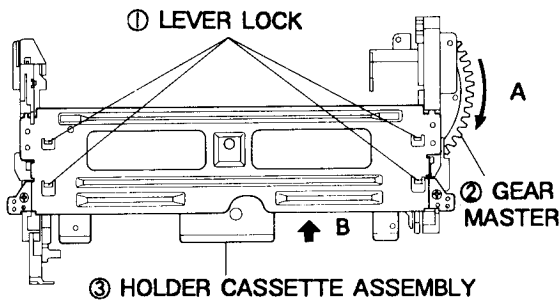

Fig. 66 How to operate the Housing Ass'y

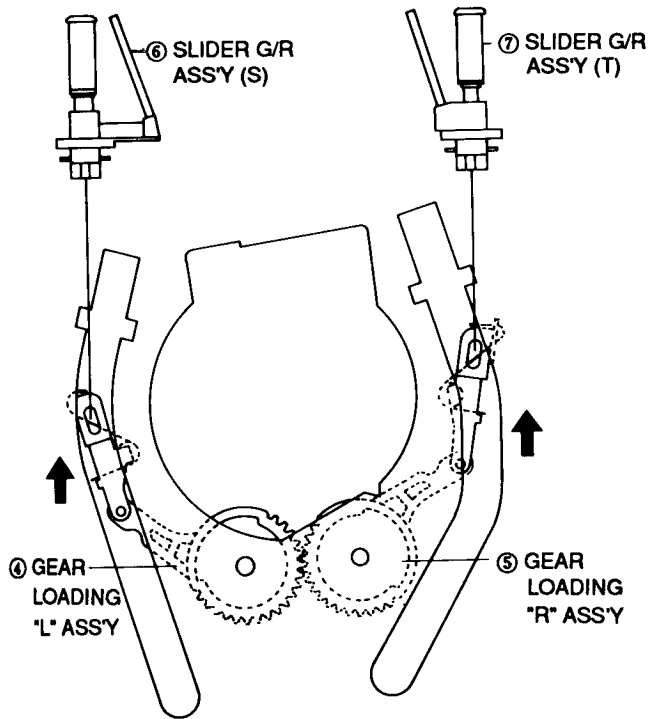

Fig. 67 Assembly of Slide Guide Roller "S", "T" Ass'y

3-2. TAPE TRANSPORT SYSTEM

Note : the tape transport system has been adjusted precisely in the factory. Alignment is not necessary except for the following:

- * Noises observed on the screen.
- * Tape damage.
- * Parts are replaced in the tape transport system.

3-2-1. Location of Tape Transport Adjustment (Adjustment Reference)

The lower flange height of the tape guide is used as the basic reference point for transport adjustments. To keep the height of the tape guide, do not apply excessive force onto the main base to prevent damage.

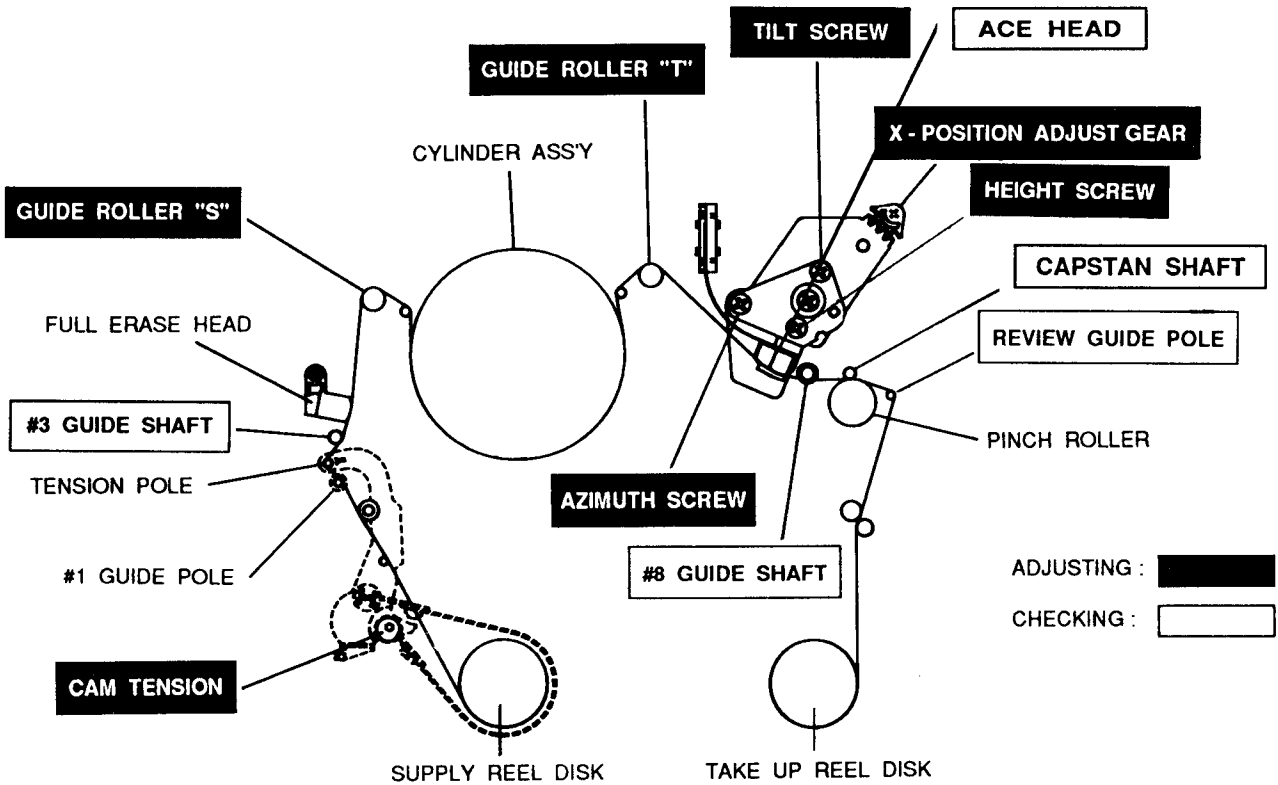

Fig. 1 Location of Tape Transport Adjustment

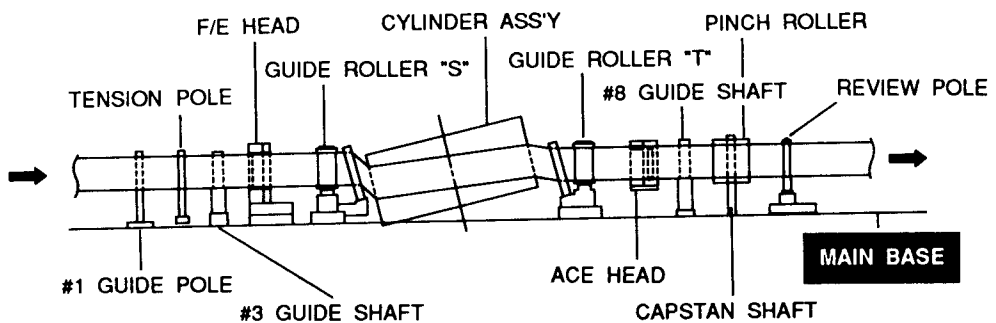

Fig. 2 Tape Travel Diagram

3-2-2. Tape Transport System Adjustment

1) Pre-adjustment

When parts are replaced, perform the required adjustments by referring to the procedures for the tape transport system. When parts are replaced, the tape path may be changed.

First run a T-160 tape and be sure excessive tape wrinkle does not occur at any tape guide.

1. If tape wrinkles at the S, T-guide rollers, turn the S, T-guide rollers until the wrinkle disappears.
2. If tape still wrinkles at the tape guide, do the tilt adjustment of the A/C head.

2) Adjustment procedures

1. A/C head assembly adjustment

Test Point : TP302 (Envelope)
 TP804 (Audio Out)
 TP202 (H'D SW Pulse - Trigger)
 TP201 (Control Pulse)
 Test Tape : ST-N1
 (Blank Tape (T-160))

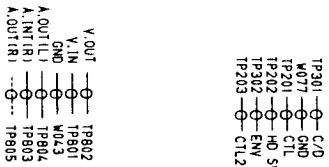

Fig. 3 Location of Test Point (Main PCB)

a. A/C head height adjustment

1. Run the alignment tape (ST-N1) in the playback mode.
2. Observe the surface of the audio head using a dental mirror.
3. Turn screws(A), (B), (C) clockwise or counterclockwise until the gap of the lower tape edge and the lower edge of the control head is about 0.25 mm. (Refer to Fig. 4. and 5.)

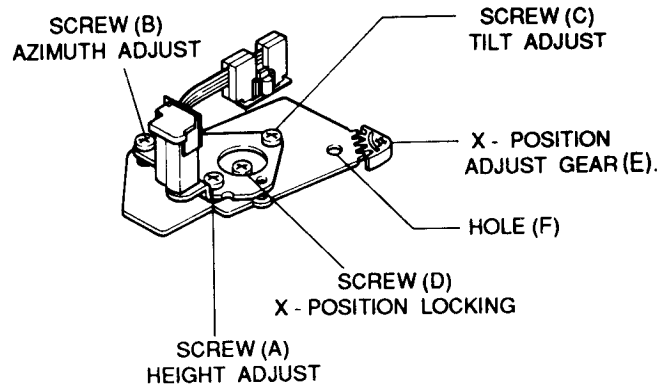

Fig. 4 Location of A/C Head Adjustment Screw

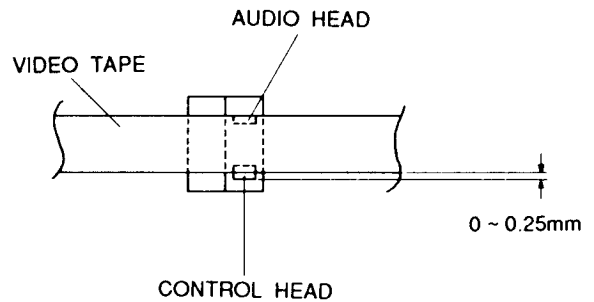

Fig. 5 A/C Head Height Adjustment

b. A/C head tilt adjustment

1. Playback a T-160 tape and observe the position of the tape at the lower flange of the tape guide.
2. Confirm that there is no curl or wrinkle at the lower flange of the tape guide, as shown in Fig. 6 (B).
3. If a curls or wrinkle of the tape has occurred, slightly turn the screw (C) tilt adjust on the A/C head ass'y clockwise until it disappears, as shown in Fig. 6 (B).
4. Reconfirm the A/C head height.

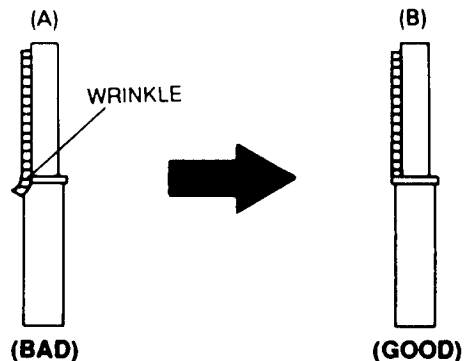

Fig. 6 Tape Guide Check

c. Audio azimuth adjustment

1. Playback the alignment tape (ST-N1)
2. Connect the channel-1 scope probe to TP804.
3. Adjust screw (B) vertically to achieve maximum audio level. (See Fig. 4)

d. A/C head position (X-Point) adjustment

1. Playback the alignment tape (ST-N1).
2. Connect the CH-1 scope probe to TP202.
3. Connect the CH-2 scope probe to TP201 and trigger head switching pulse.
4. Set the tracking preset to "6.5 ms" using the tracking button ▲/▼ of remote control. (Refer to Fig. 7 and 8)
5. Connect the CH-1 scope probe to TP302 and the CH-2 scope probe to TP202 trigger on CH-1.
6. Turn the screw (E) counterclockwise (See Fig. 4).
7. Insert the adjusting driver (+) into X-position adjusting gear. Adjust the driver in either direction for maximum envelope waveform.

NOTE : Since the adjusting gear unit may be damaged, do not adjust by force when adjusting the X-point using the adjusting driver (+). After turn the X-point adjusting screw(D) counterclockwise a little, preform the adjustment. After adjustment is completed, tighten the screw.

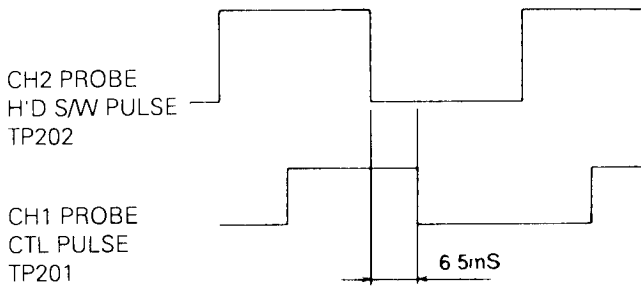

Fig. 7 Tracking Preset Adjustment

REMOTE BUTTONS	CONTROL PULSE MOVEMENT
PUSH Tracking	
 Tracking PUSH	

Fig. 8 Control Pulse Adjustment

2. Linearity adjustment (S,T-guide rollers adjustment)

Test Point : TP302 (Envelope)
 TP202 (H'D SW Pulse - Trigger)
 Test Tape : (Mono Scope ; 7KHz)

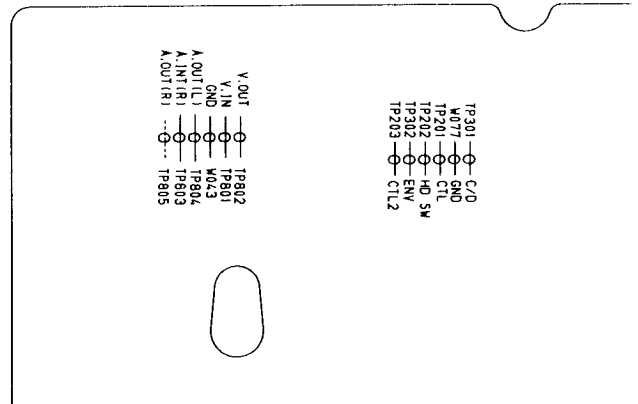

Fig. 9 Location of Test Point (Main PCB)

1. Playback the alignment tape (Mono Scope ; SP).
2. Observe the video envelope signal on an oscilloscope triggered by the head switching pulse.
3. Make sure the video envelope waveform (in its minimum or maximum output) meets the specification shown in Fig. 10. If it does not, adjust as follows ;

NOTE :

- a**=Maximum output of the video RF envelope.
- b**=Minimum output of the video RF envelope at the entrance side.
- c**=Minimum output of the video RF envelope at the center point.
- d**=Minimum output of the video RF envelope at the exit side.

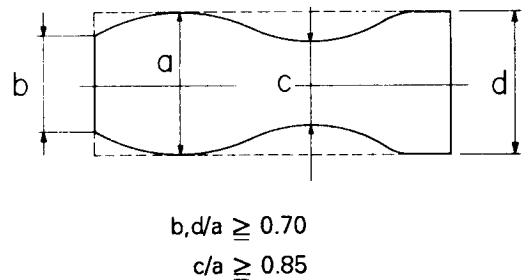

Fig. 10 Envelope Waveform Adjustment

- 4. If the section A in Fig. 11 does not meet the specification, adjust the S-guide roller up or down.
- 5. If the section B in Fig. 11 does not meet the specification, adjust T-guide roller up or down.

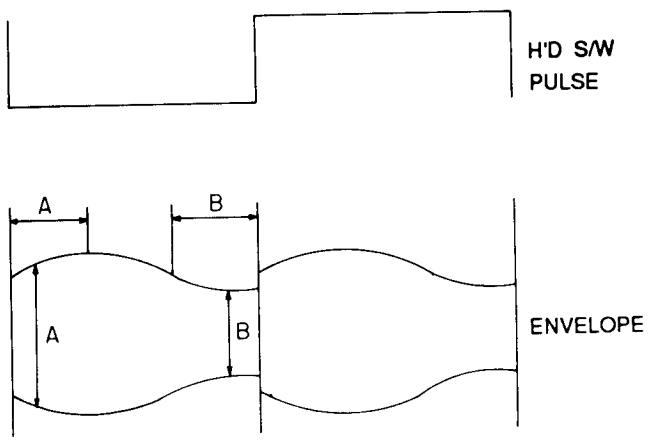

Fig. 11. Adjustment Points

- 6. Slightly loosen the set screw at the lower part of the S, T-guide rollers with a (Hex Wrench - 0.9mm) so that the guide roller can be adjusted with reasonable tightness. (Refer to Fig. 12)

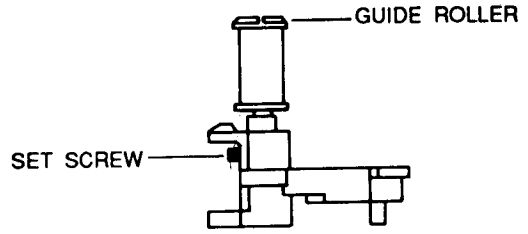

Fig. 12

- 7. Playback the alignment tape (Mono Scope ; SP).
- 8. Connect an oscilloscope CH-1 to TP302 and CH-2 to TP202 on the same PCB for triggering.
- 9. Turn the guide roller heads with a flat head (⏏) screw driver to obtain flat video RF envelope as shown in Fig. 13.
- 10. After the adjustment is completed, tighten the set screws.

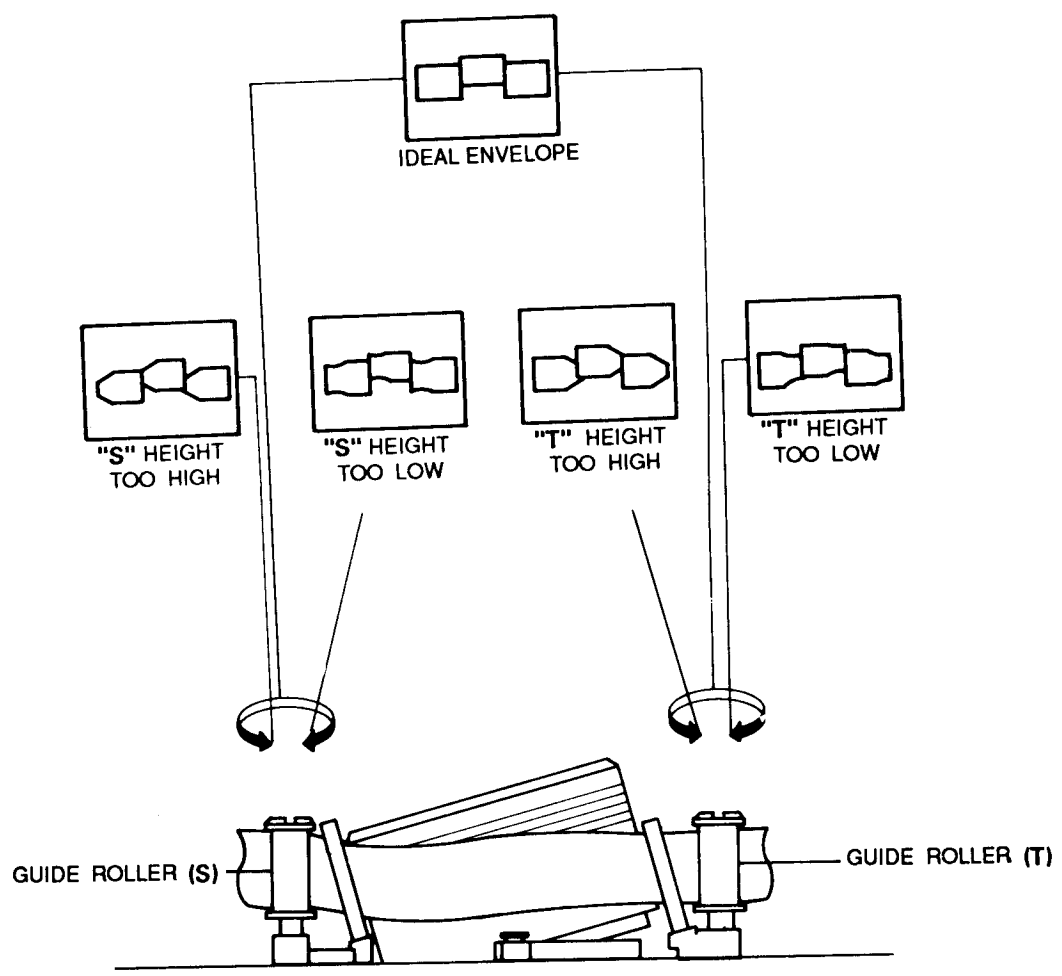

Fig. 13 S, T-Guide Roller Height Adjustments

3. Check for transitional operation from R.P.S to play

Check transition from R.P.S mode to play mode, using a pre-recorded SP tape, make sure the entrance side of envelope comes to an appropriate steady state within 3 seconds as shown in Fig. 14.

If the envelope waveform does not reach specified peak-to-peak amplitude within 3 seconds, adjust as follows :

1. Make sure there is no gap between the supply roller lower flange and the tape. If there is a gap, adjust the supply guide roller again.
2. Change operation mode from the R.P.S to the play mode again and make sure entrance side of envelope rises within 3 seconds.

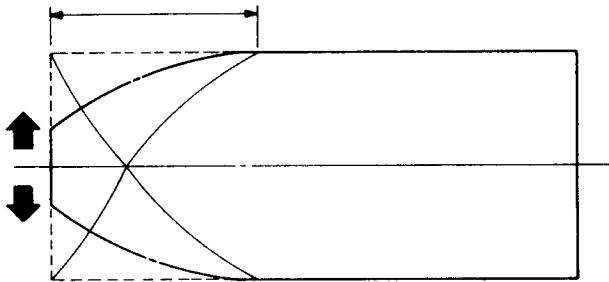
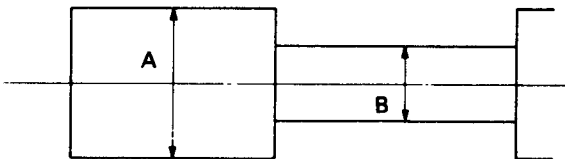

Fig. 14 Video envelope rising when operation mode is switched from R.P.S to play mode.

4. Envelope check

1. Make recordings on T-120 and T-160 tapes, and make sure the playback output envelope meets the specification as shown in Fig. 15.
2. Playback a self recorded tape (recording made on this unit), (with a T-120) the video envelope should meet the specification as shown in Fig. 15. In SLP mode, (A) should be same as (B). If the head gap is wide, the upper cylinder should be checked.



$$B/A \geq 0.55$$

$$B/ \geq 150\text{mV}$$

Fig. 15 Envelope Output and Output Level Difference

5 Tape wrinkle check

1. Run T-160 tape in playback, FPS, RPS and the pause mode and observe tape wrinkle at each guide.
2. If excessive tape wrinkle is observed in the mode shown below, perform the associated adjustment shown below.

a. Playback mode

- Tape wrinkle at the S,T-guide roller section : Linearity adjustment.
- Tape wrinkle at tape guide flange : A/C head assembly coarse adjustment.

3-3. REEL TORQUE

3-3-1. Reel Torque

1. The rotation of the capstan motor operates the clutch ass'y through the capstan motor belt.
2. Brake operation and shift operation in FF/REW are done by a slide lever.
3. Transmission of accurate driving force is done by gears. (clutch ass'y)

MODE	TORQUE g/cm	GAUGE
PB/REC	100±30	Cassette Torquemeter
RPS	170±30	Cassette Torquemeter
FF/REW	Min 300g/cm	Torque Gauge

NOTE : If the spec is out of above chart, replace the clutch ass'y and then recheck.

3-3-2. Location of Tension Pole and Back Tension Adjustment

1. Remove the housing ass'y and set the deck to play mode.
2. Adjust the tension cam to 2.5~3.5mm from the center of the supply roller.
3. The back tension meter should be used for checking the back tension.

Back tension, should be 41 - 51g.cm.
If it is not, adjust the tension cam.

Counterclockwise : Torque UP
Clockwise : Torque DOWN

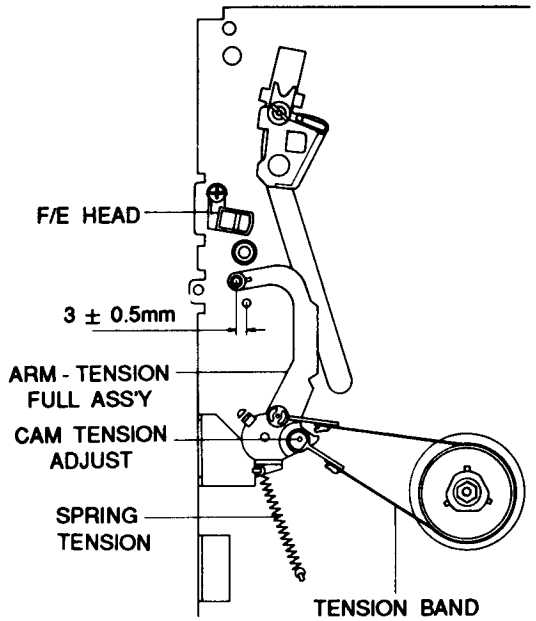

Fig. 16 Tension Pole and Back Tension Adjustment

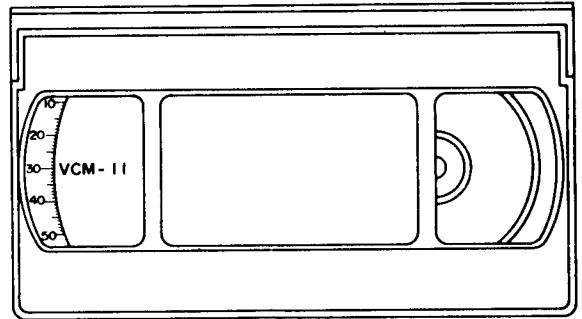
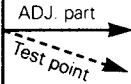

Fig. 17 Back Tension Tape Torque Cassette

4-2. SERVO/VIDEO SECTION ADJUSTMENT

Step	Adjustment Item
1.	Mode and input signal/ Alignment tape
2.	Test point and ADJ. part
3.	Result & Remarks



1. Head Switching Point

- 1) "PB", Alignment tape color bars.
 - 2) TP202 (H'D S/W), TP802(Video out) & VR201.
 - 3) * Connect an oscilloscope's CH-1 to TP202 for triggering and CH-2 to TP802.
- * Adjust VR201 so that the head switching point is positioned $6.5H \pm 0.5H$ from the V-SYNC left edge as shown.

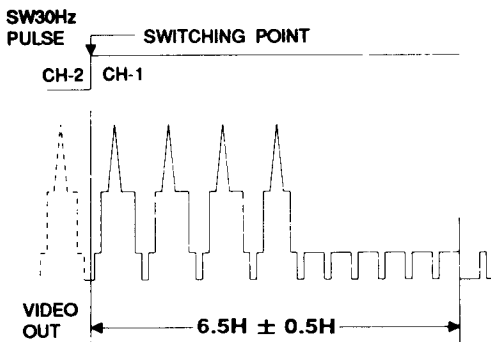

2. CCD COMB

- 1) "E-E"(Stop Mode), 2Vp-p color bar signal.
(V. IN jack on the rear panel)
- 2) D308 & VR301.
- 3) * Push the "LINE IN" button on the remote control to receive LINE signal
* Connect an oscilloscope's CH-1 to D308 and set the VCR to REC mode.
* Adjust VR301 to make minimum color portion on the color bar signal.

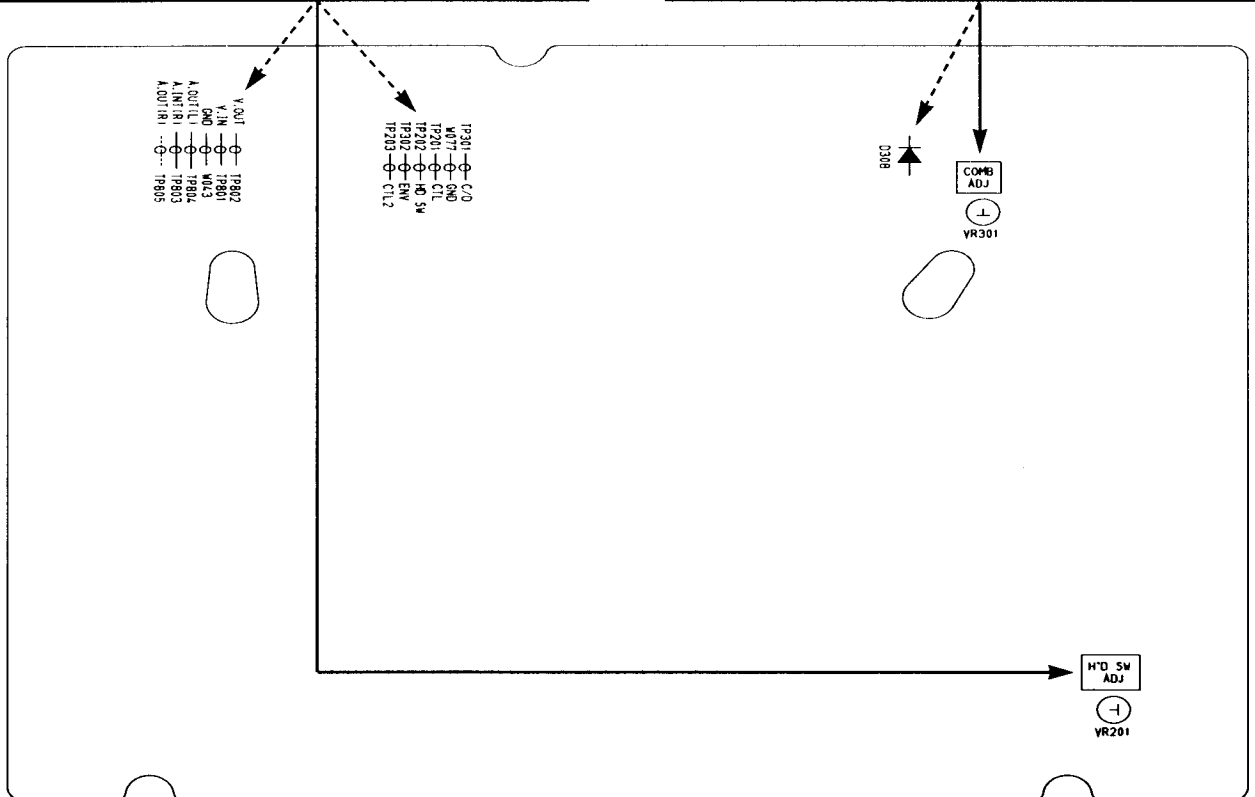
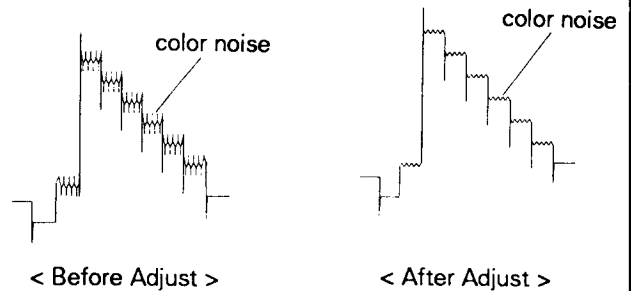

(Main PCB-Top Side)

7-1. PACKING ASSEMBLY

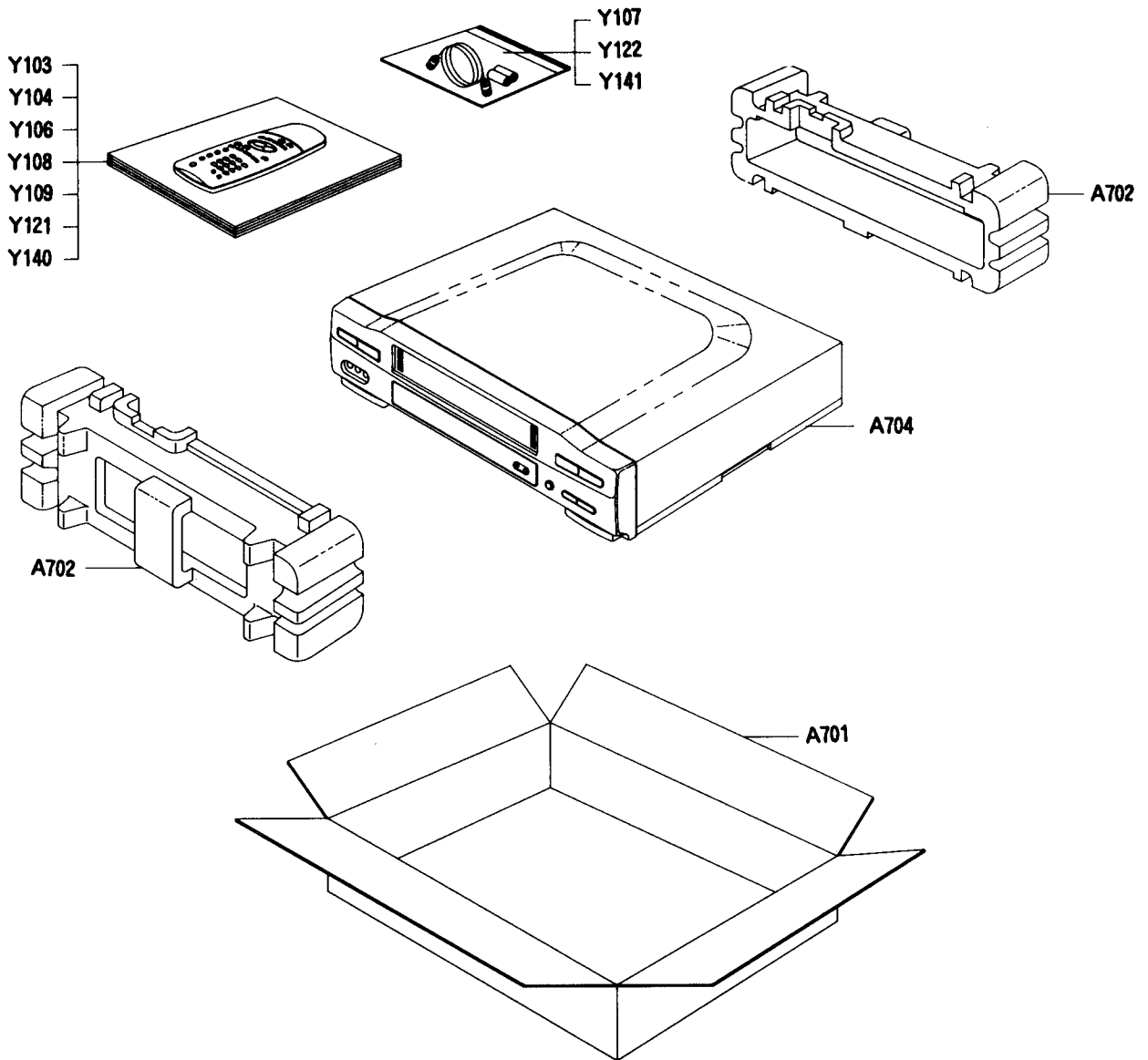

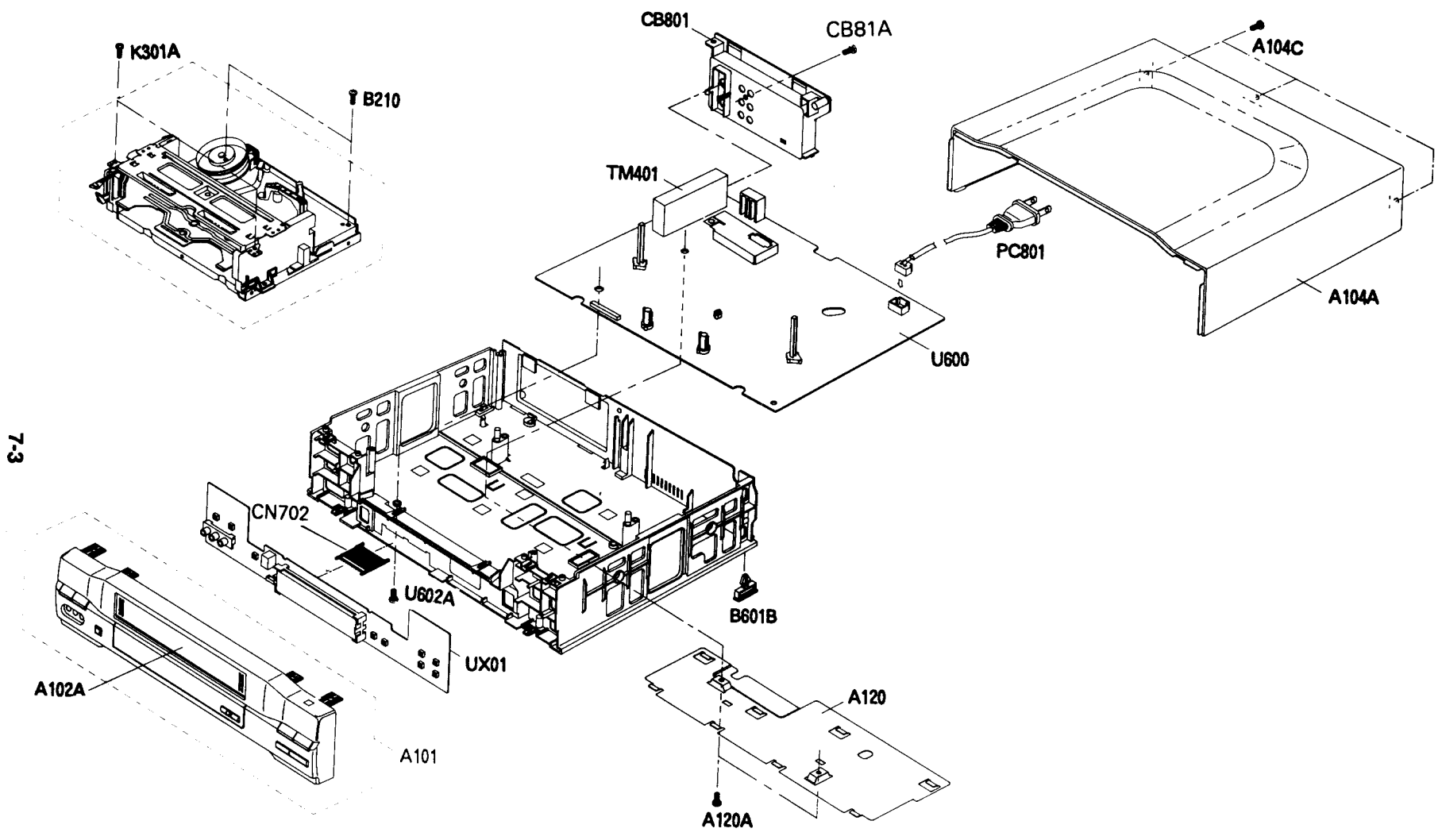

7-3. MECHANICAL ASSEMBLY(1)

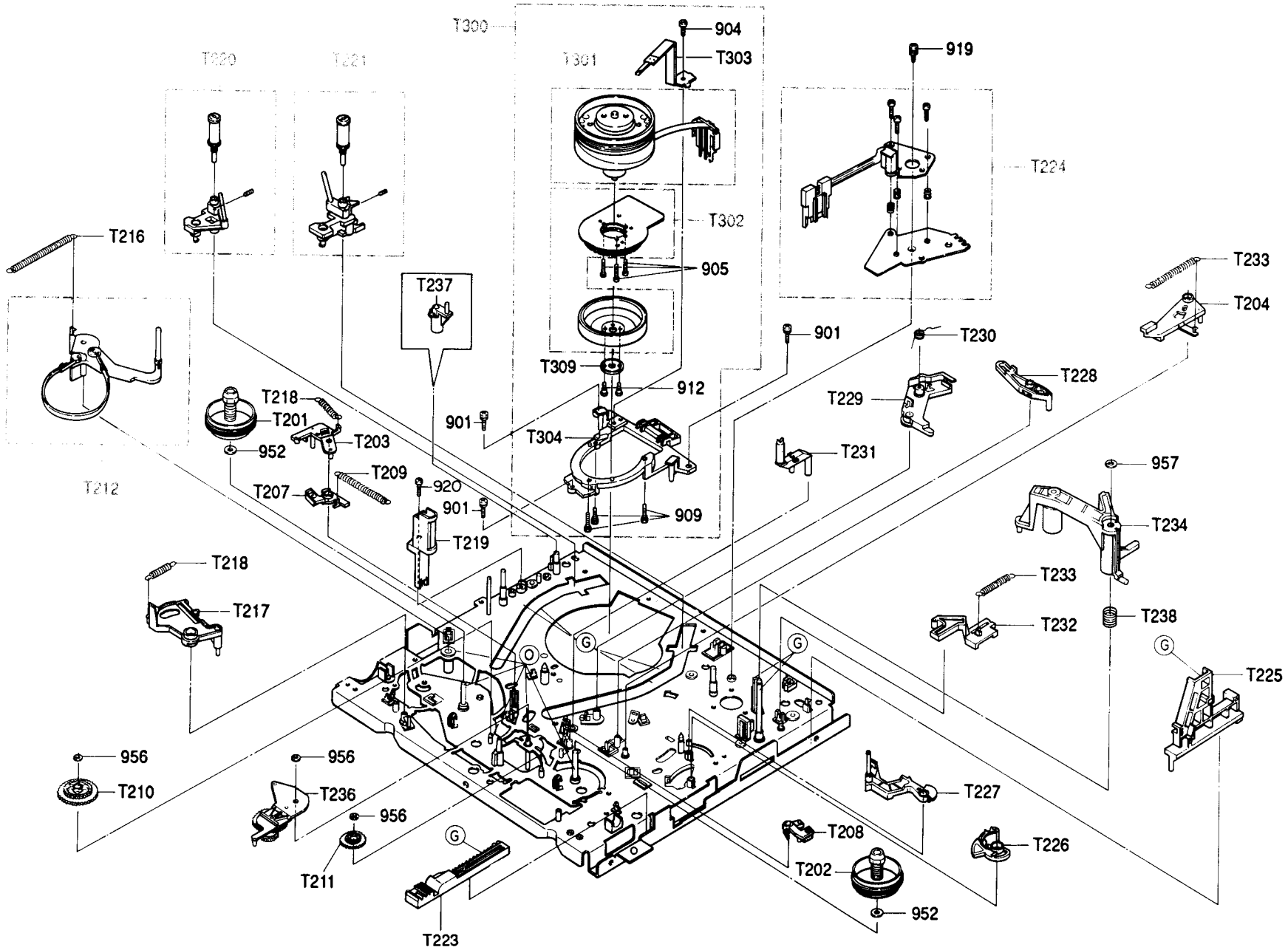

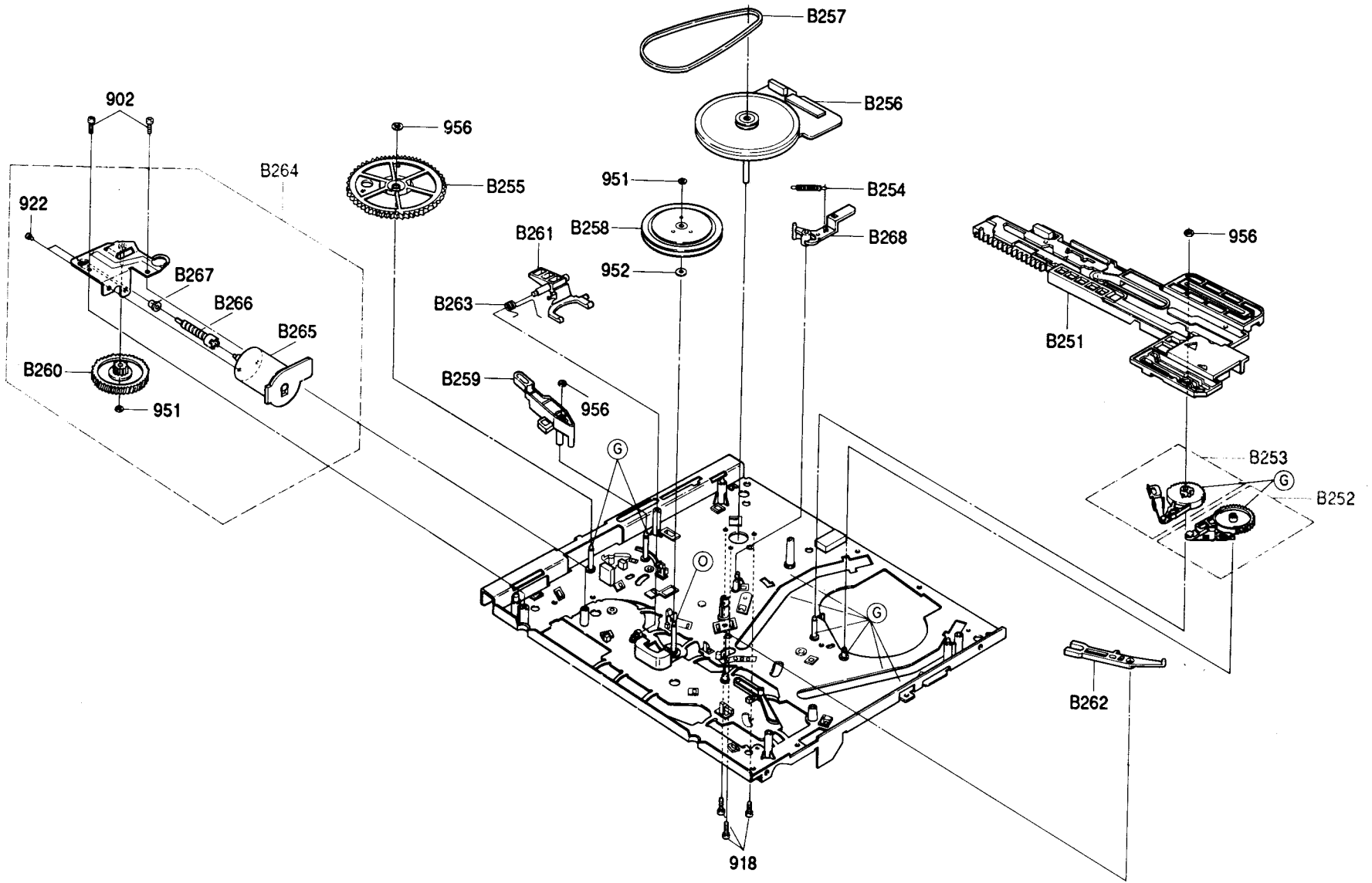

7-5. HOUSING ASSEMBLY

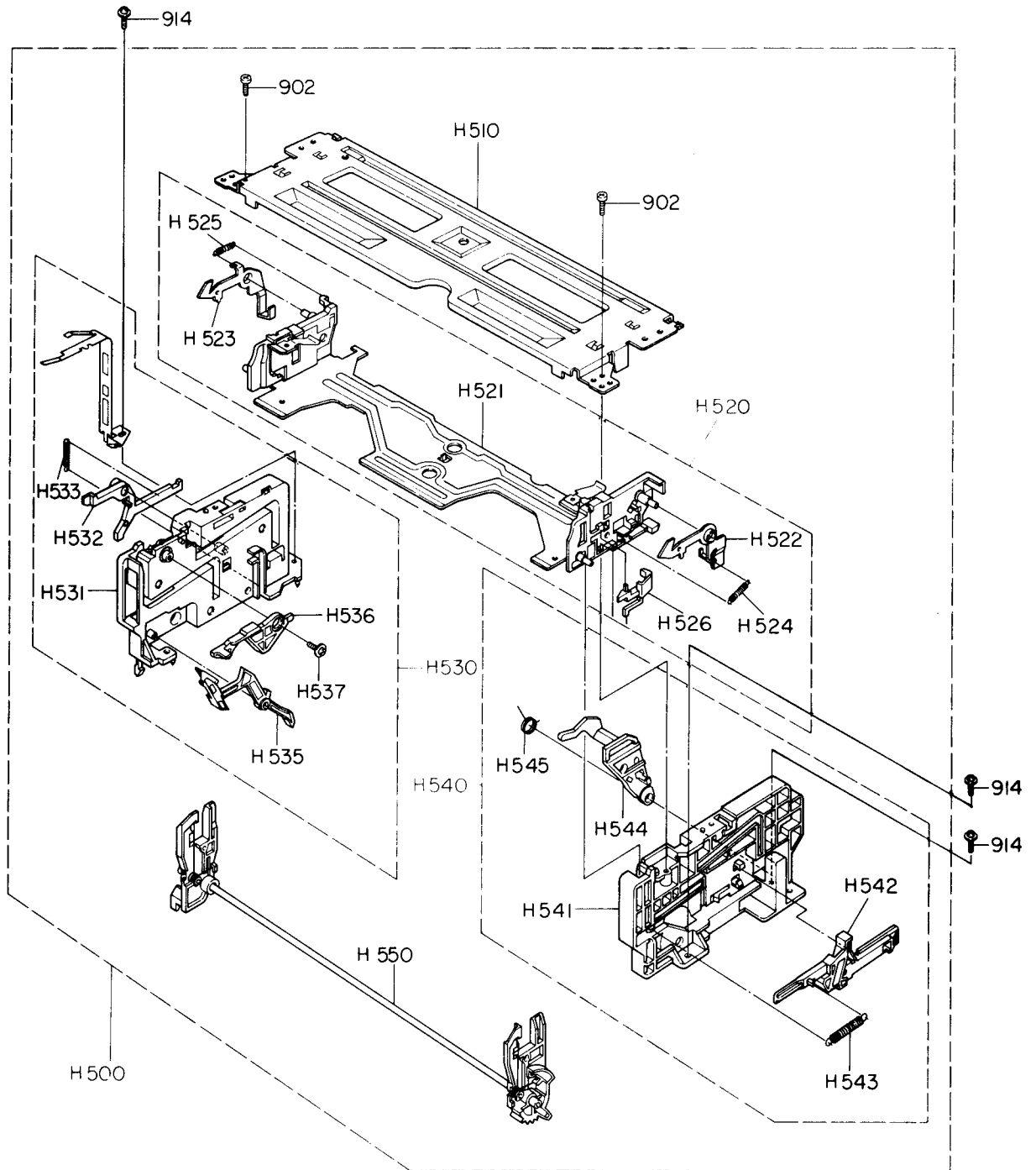

7-6. REMOTE CONTROL ASSEMBLY

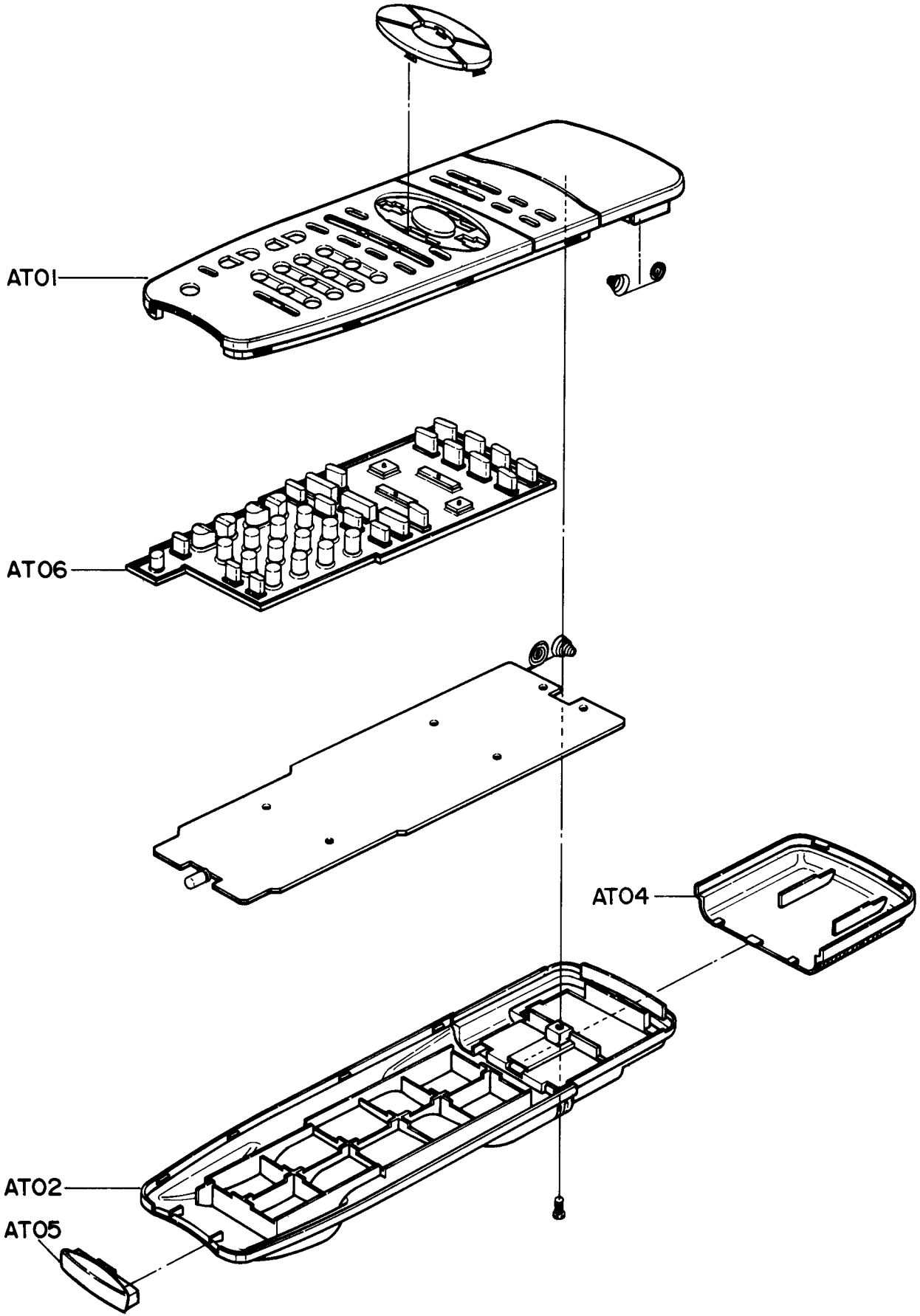

8-1. TOTAL WIRING DIAGRAMS

TOTAL WIRING DIAGRAM

MAIN ASS'Y

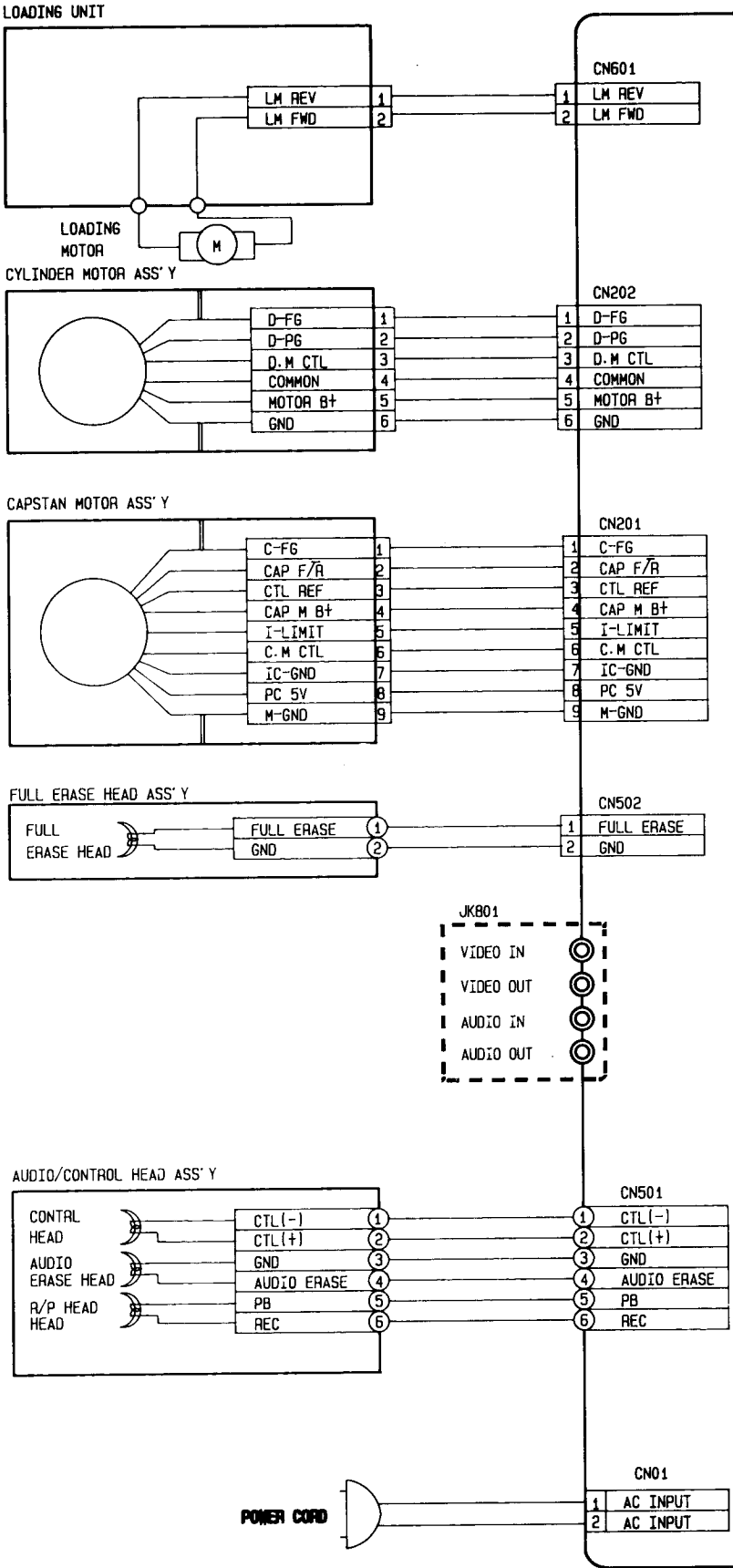

GRAM

Y

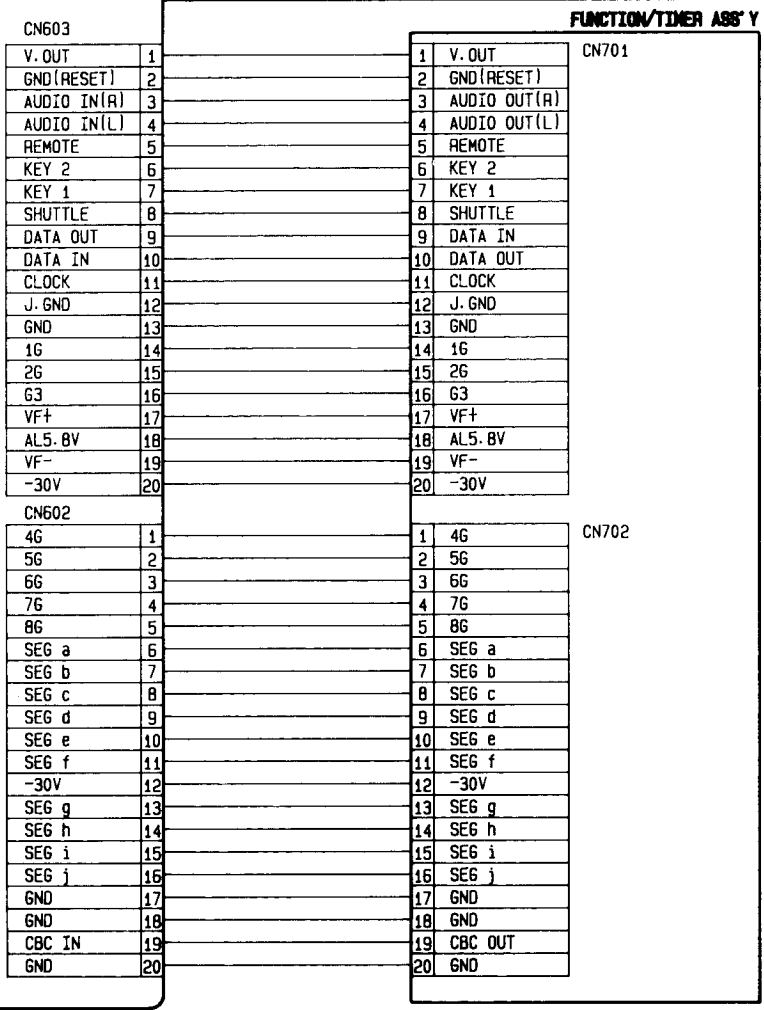
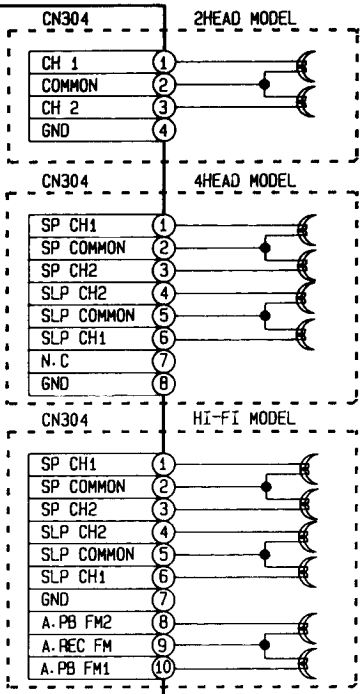
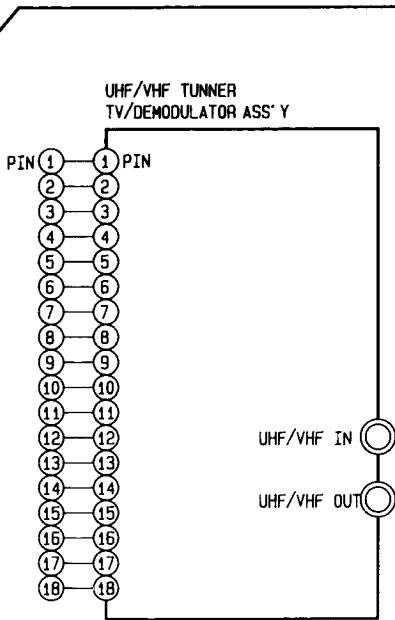

8-2. VIDEO

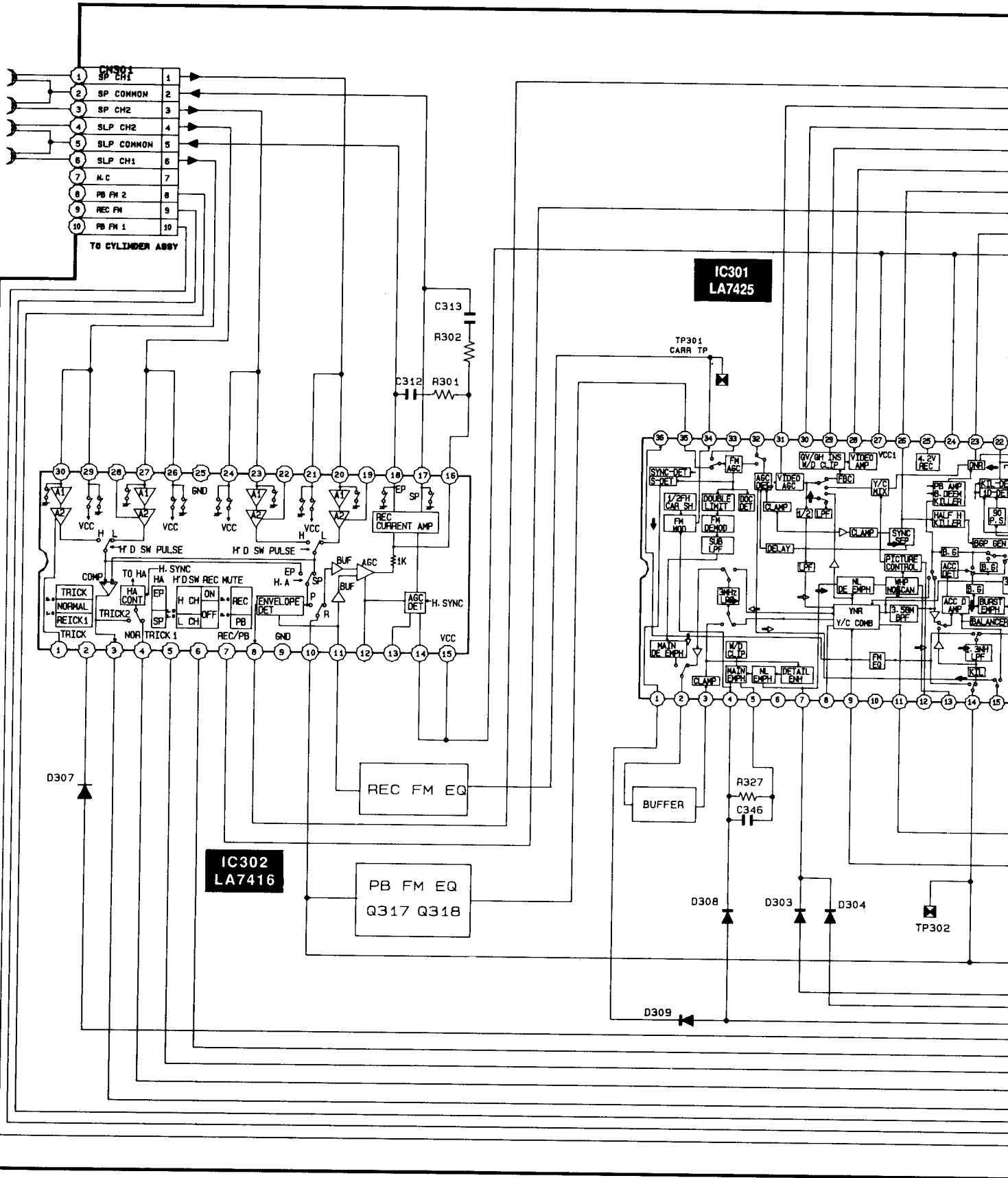

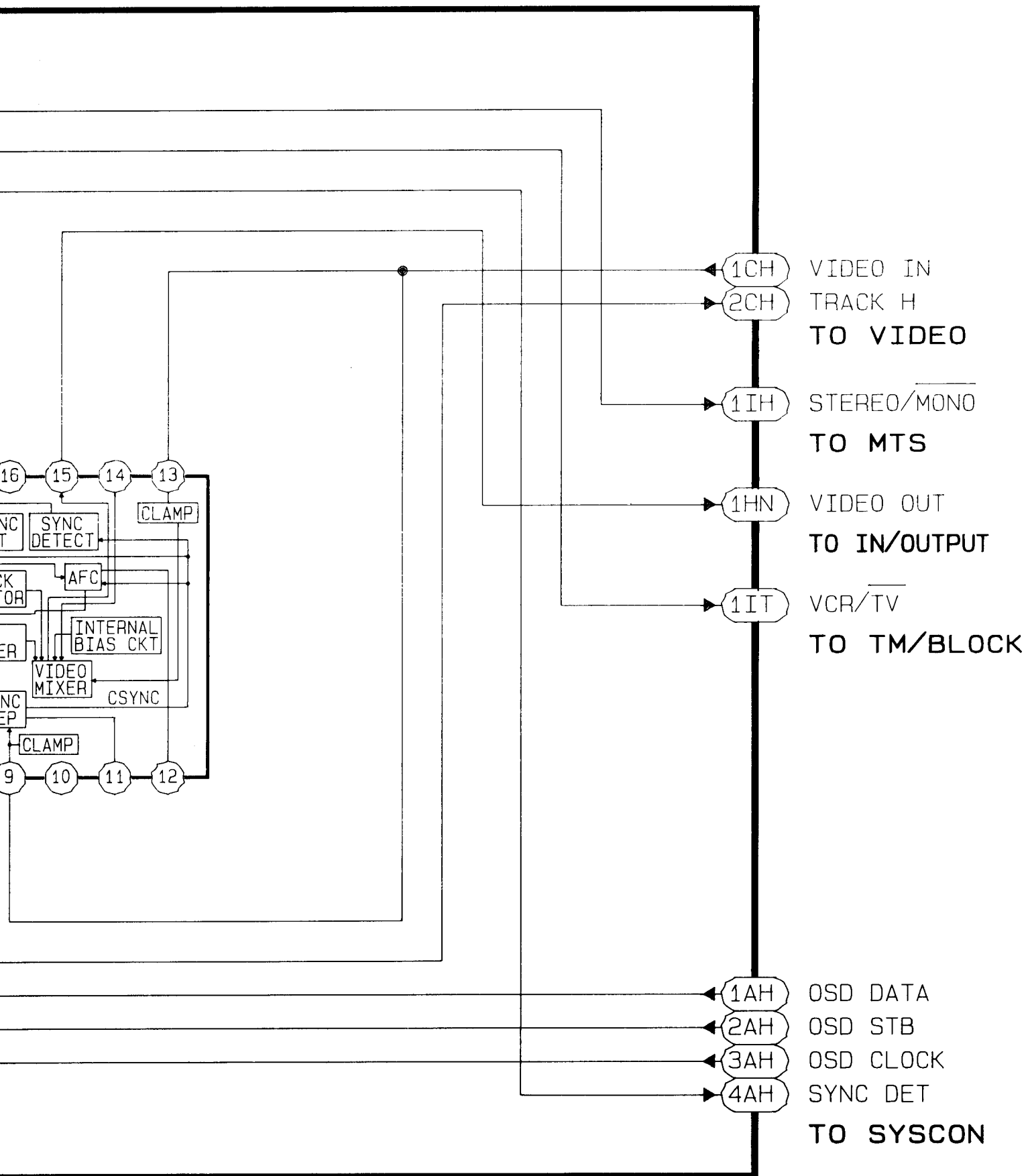

3. OSD

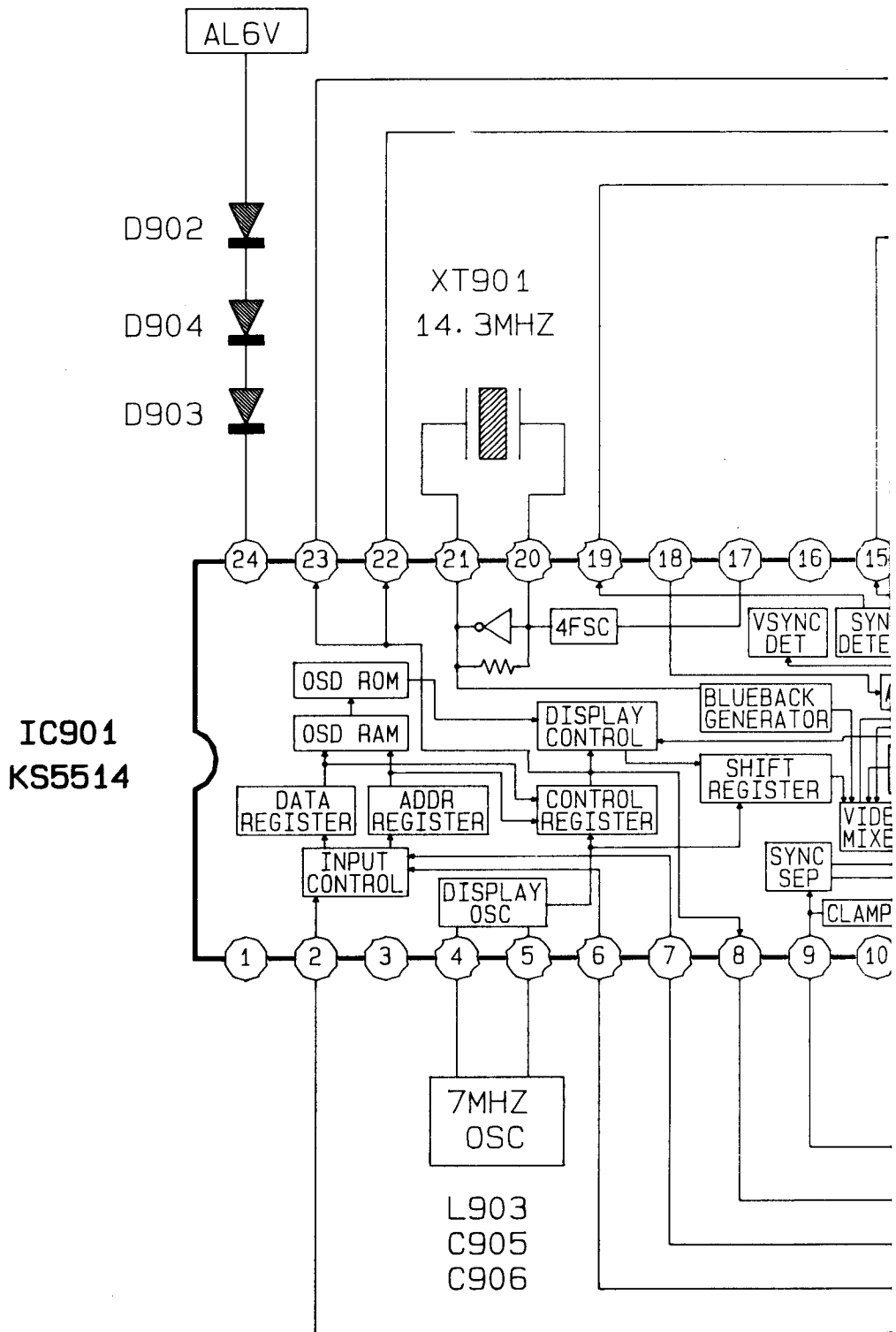

NOTE

- For Schematic Diagram
 - Resistors are in ohms, 1/8W unless otherwise noted.
 - Circled numbers refer to waveforms.

SPECIAL NOTE :

All integrated circuits and many other semiconductor devices are electrostatically sensitive and therefore require the special handling techniques described under the "electrostatically sensitive (ES) devices" section of this service manual.

NOTE :

Do not use the part number shown on this drawing for ordering. The correct part number is shown in the parts list. And may be slightly different or amended since this drawing was prepared.

IMPORTANT SAFETY NOTICES :

Components identified with the mark  have the special characteristics for safety when replacing any of these components. Use only the same type.

* BLOCK IDENTIFICATION OF MAIN PCB

(TOP SIDE)

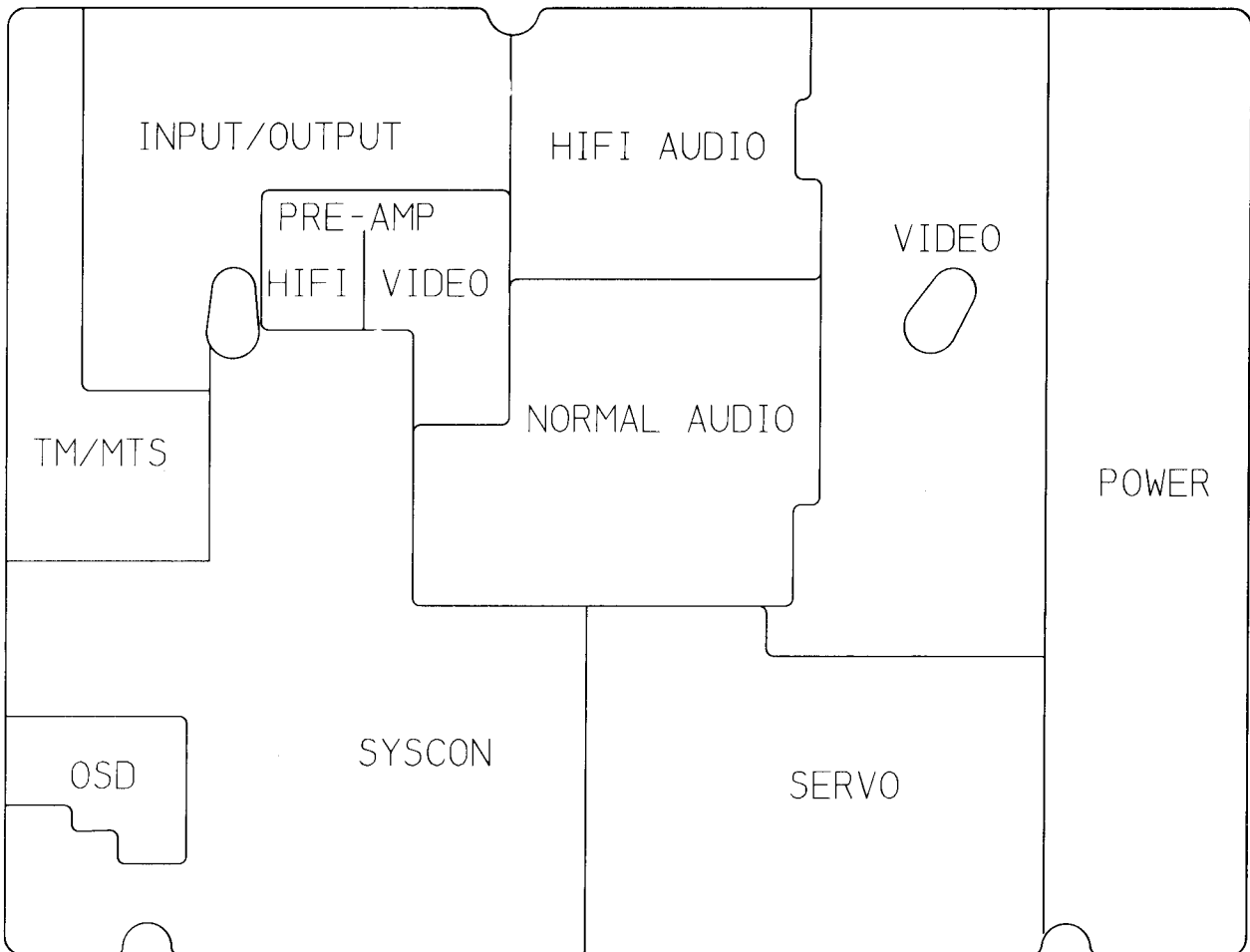

10-1. PRE/AMP(M672/M672C/M662/M662C/M65/M65C)

IC522
BA7746FS
PRE-AMP

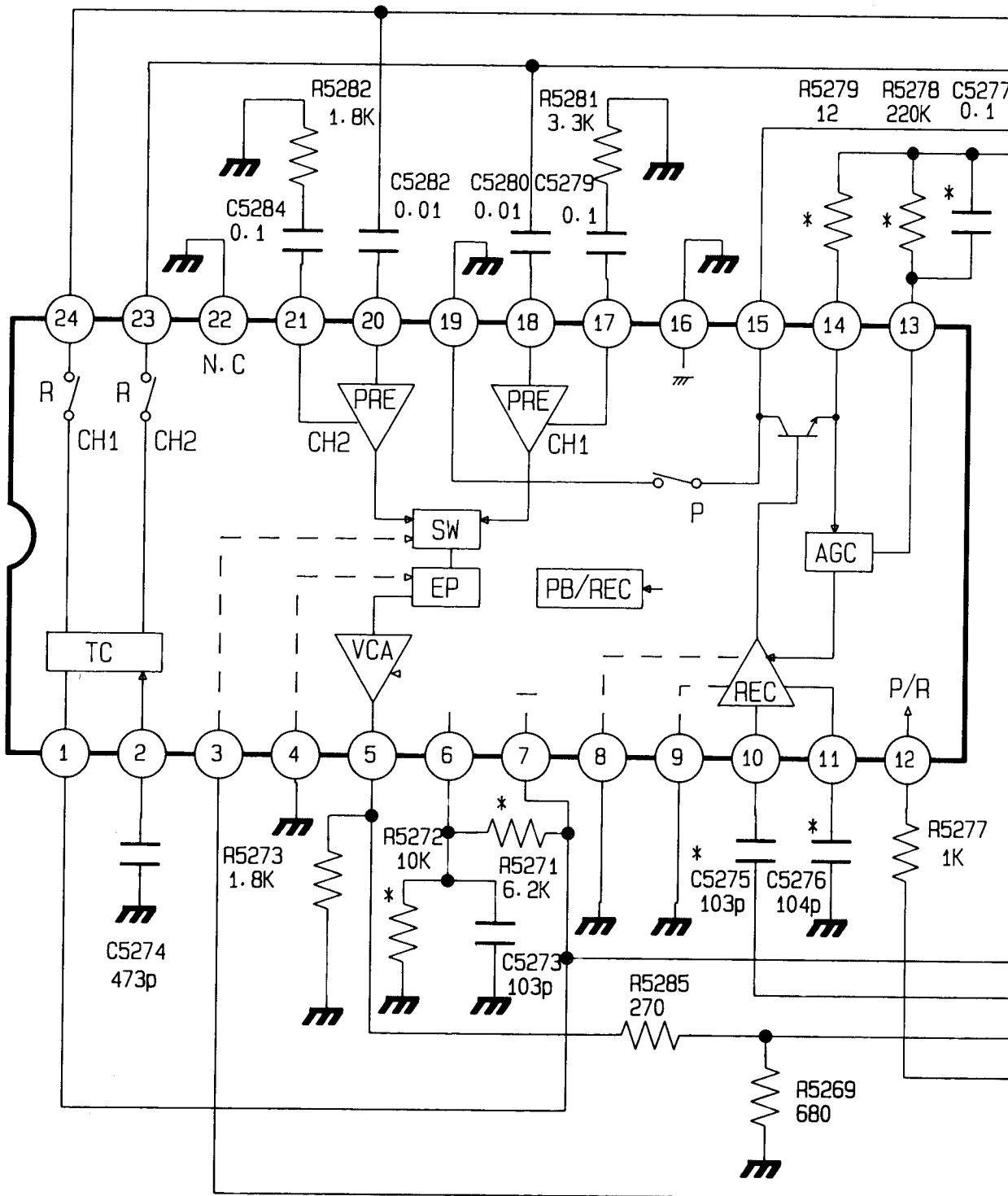

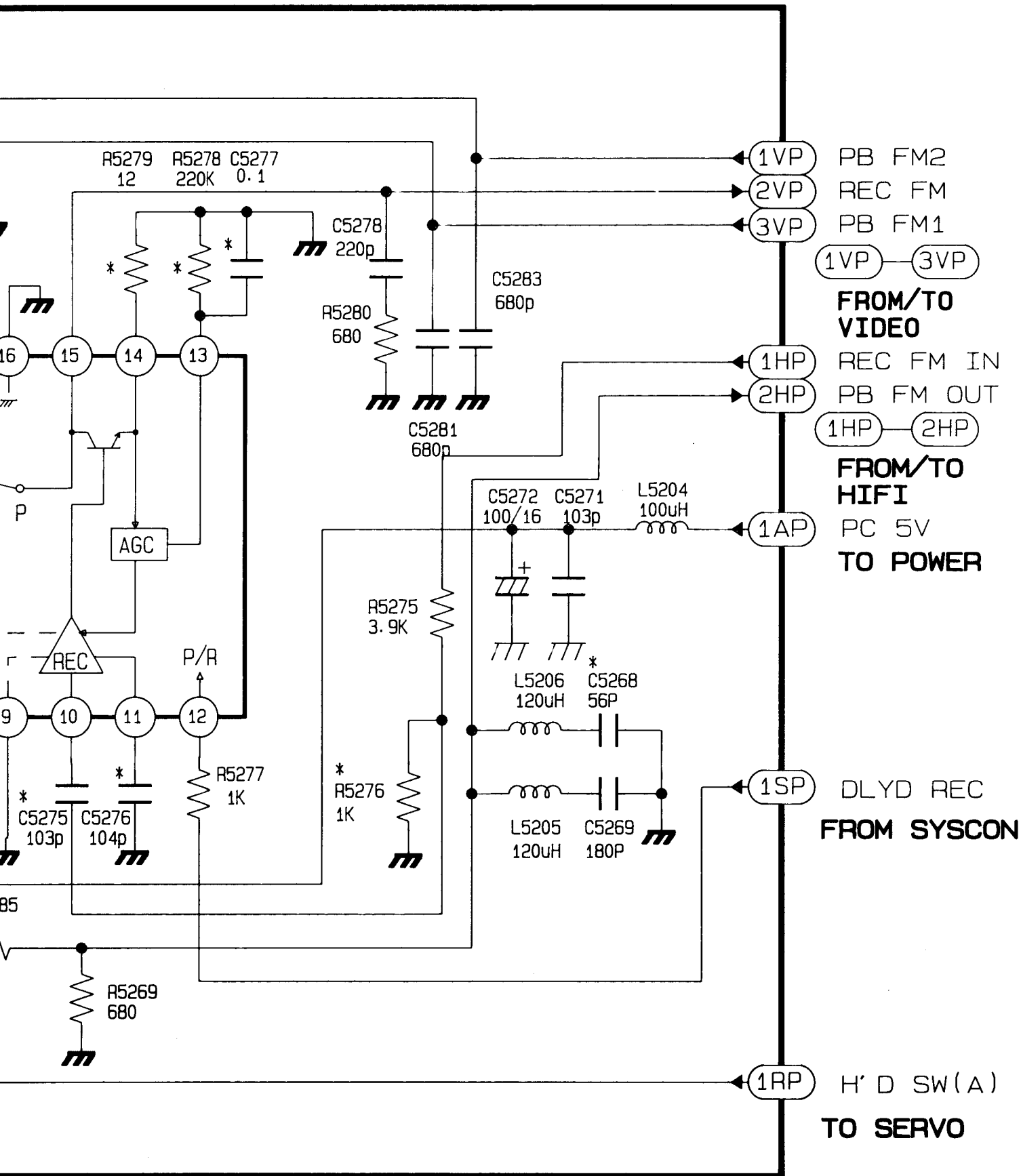

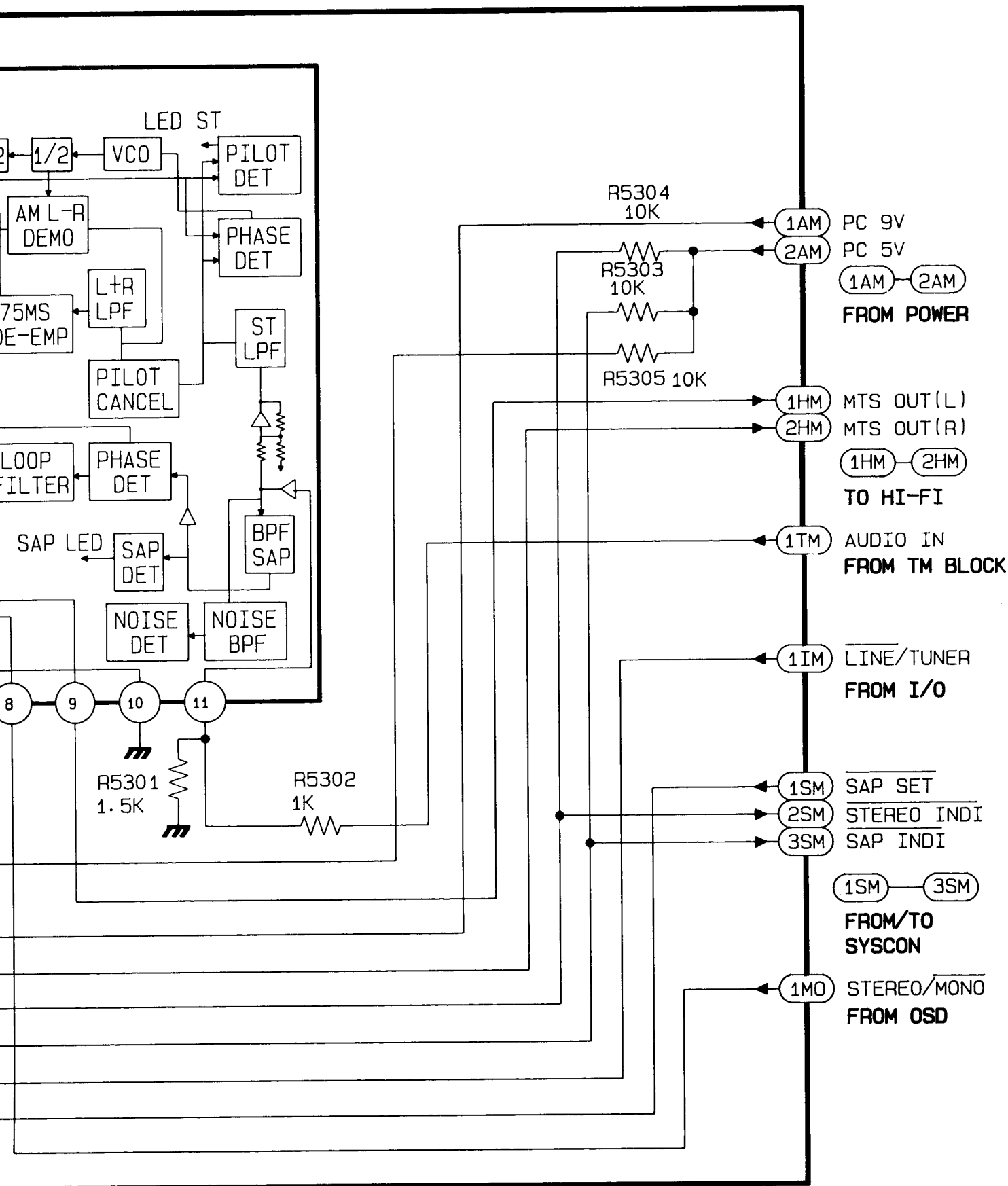

IC531
SVM-04
MTS

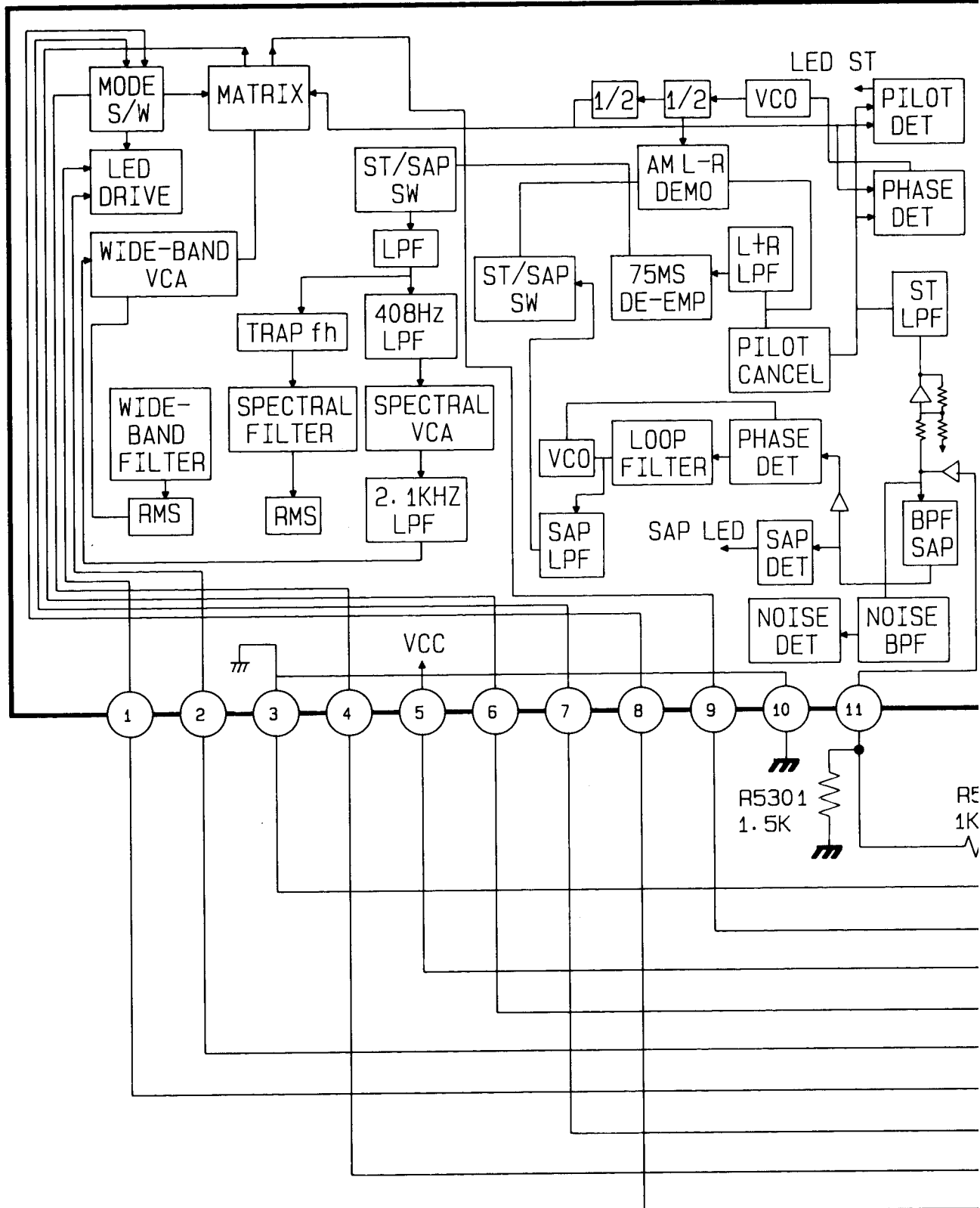

10-3. I/O (M472/M462/M45)

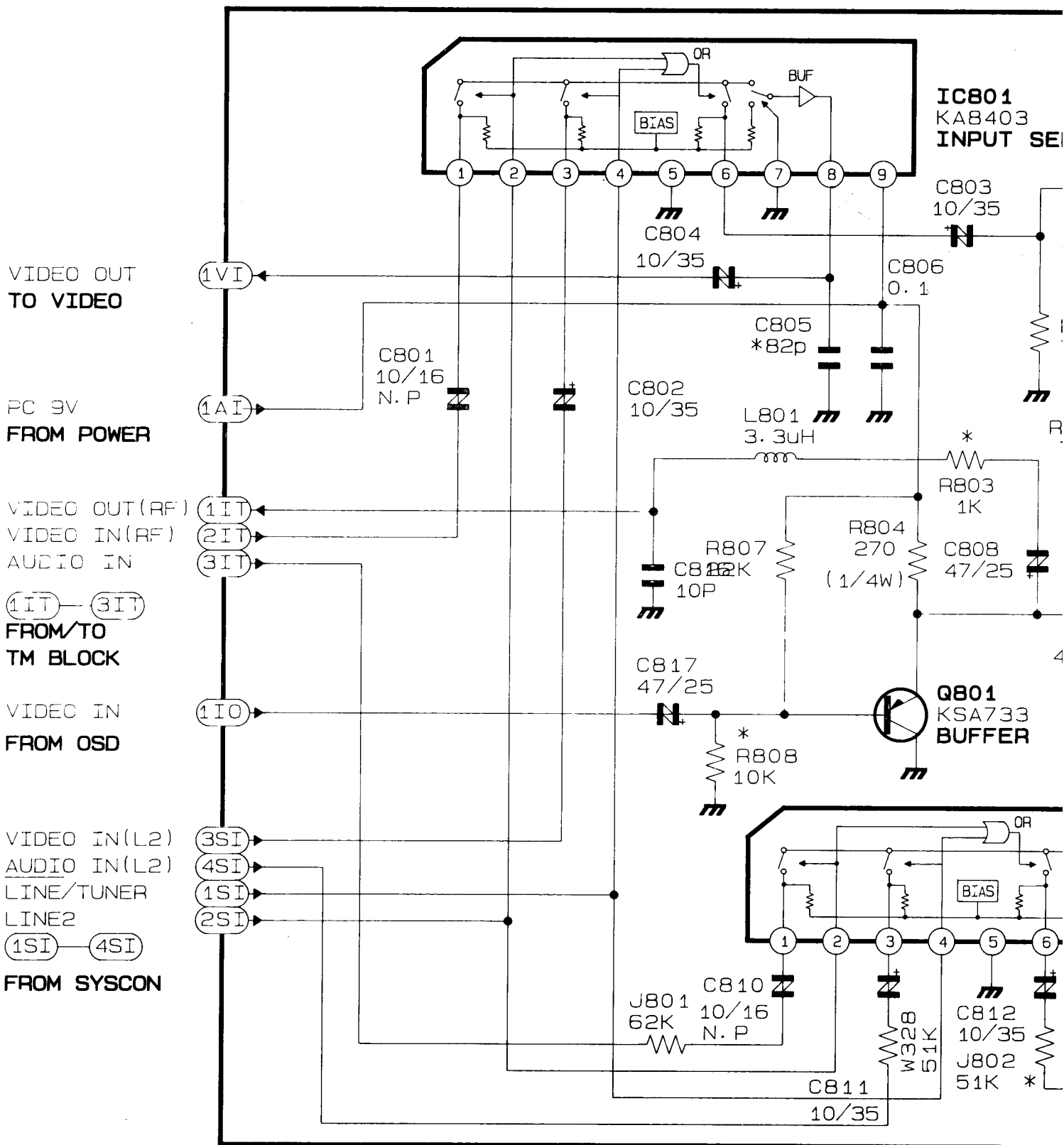

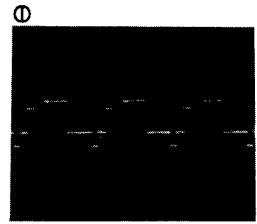
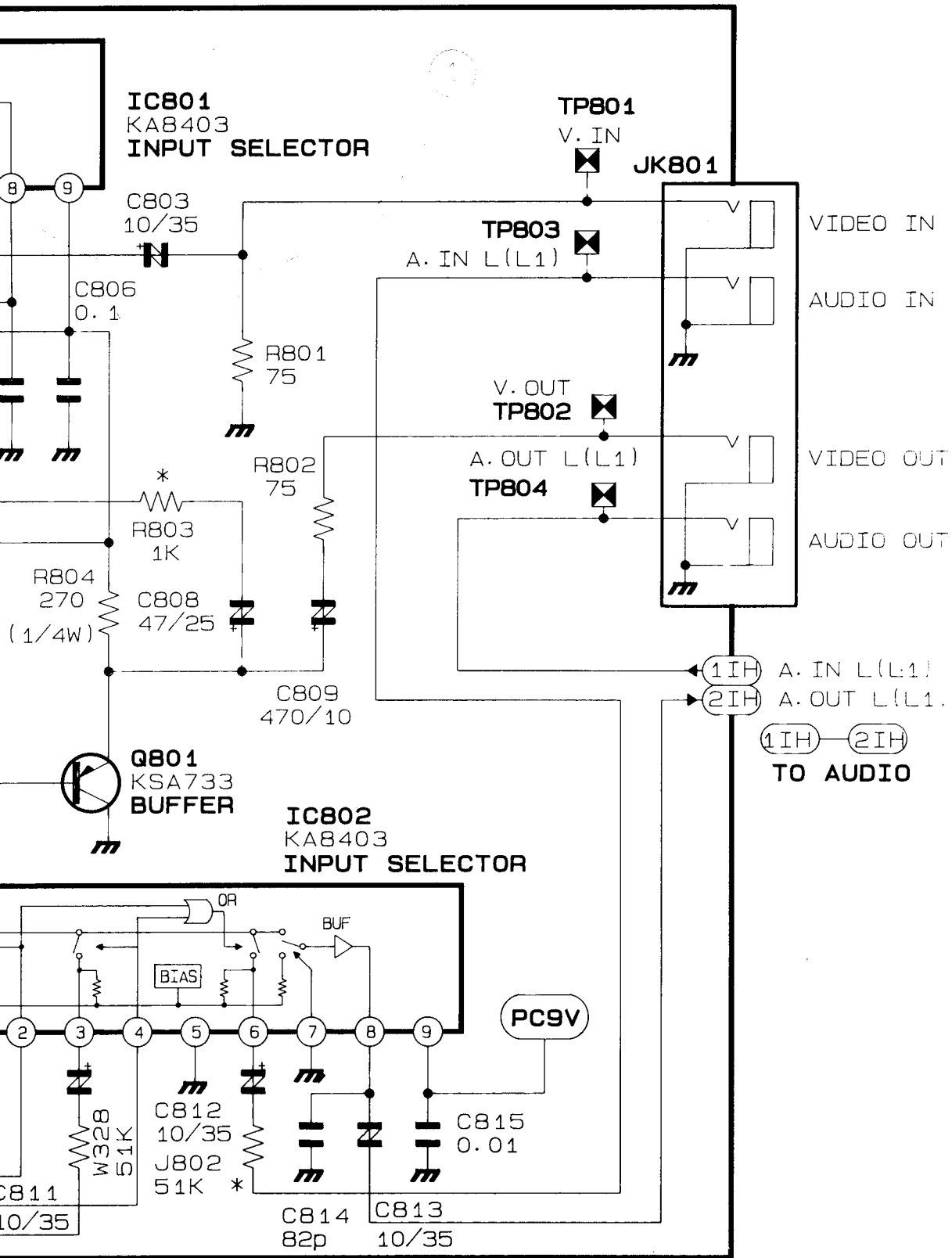

IC801-8
1.0Vp-p
REC

MODE LOCA.NO	STOP	REC	PLAY
IC801			
1	6.1	6.1	6.1
2	4.6	0	0.9
3	6.1	6.1	6.1
4	0.8	0.8	4.5
5	0	0	0
6	6.1	6.1	6.1
7	0	0	0
8	5.3	5.3	5.3
9	8.9	8.9	8.9
Q801			
E	4.3	4.3	4.3
B	3.6	3.6	3.6
C	0	0	0

10-4. REMOTE CONTROL

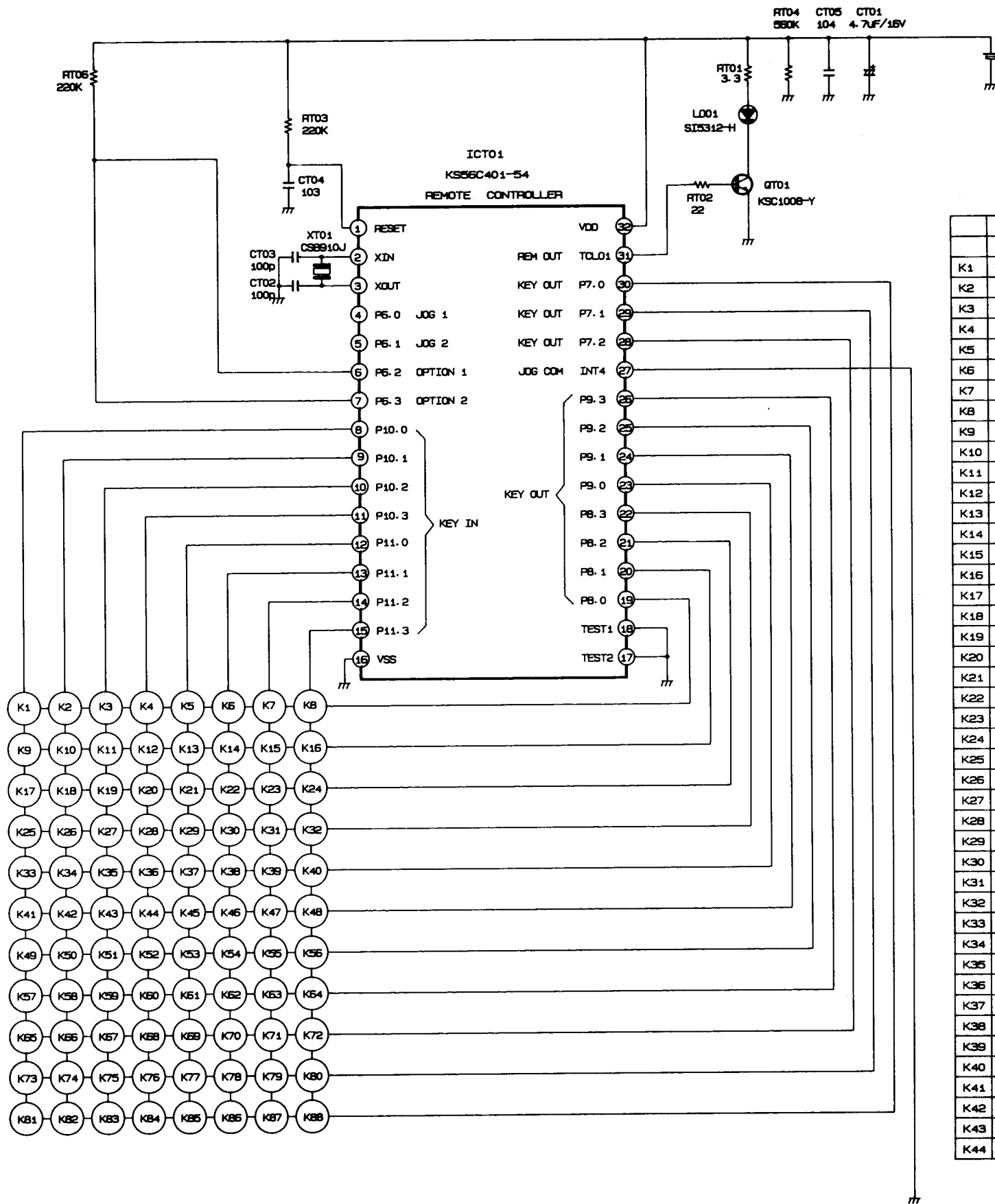

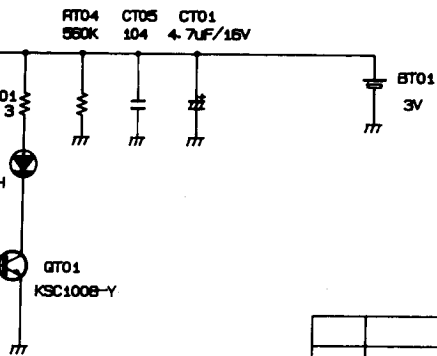

KEY MATRIX

	KEY NAME			KEY NAME	
	SEJ	TSB		SEJ	TSB
K1	VCR POWER		K45	MUTE	MUTE
K2	TV POWER		K46	VOLUME UP	VOLUME UP
K3	POWER(VCR/TV)	POWER(VCR/TV)	K47	VOLUME DOWN	VOLUME DOWN
K4	PLAY	PLAY	K48		OTR(OTR OFF)
K5	STOP	STOP	K49		
K6	FAST FORWARD	FAST FORWARD	K50		
K7	REWIND	REWIND	K51		
K8	VCR	VCR	K52		
K9	1	1	K53		
K10	2	2	K54		
K11	3	3	K55		
K12	4	4	K56		
K13	5	5	K57		
K14	6	6	K58		
K15	7	7	K59		
K16	TV	TV	K60		
K17	8	8	K61		
K18	9	9	K62		
K19	0	0	K63		
K20	100	100	K64	SHUTTLE 4	SHUTTLE 4
K21	MENU(PROGRAM)	MENU(PROGRAM)	K65	SHUTTLE(+)	
K22	INDEX	INDEX	K66	SHUTTLE(-)	
K23	TAPE SPEED	TAPE SPEED	K67	MEMORY	
K24	TV/VCR	TV/VCR	K68	ZERO RETURN	CBC POWER
K25	AUDIO OUT SELECT	AUDIO OUT SELECT	K69	PB X 2	CBC CH UP
K26	INPUT SELECT	INPUT SELECT	K70	TV/CATV	CBC CH DOWN
K27	CH UP	CH UP/TRK+	K71	CLOCK/COUNTER	REMAIN/COUNTER
K28	CH DOWN	CH DOWN/TRK-	K72	SHUTTLE 3	SHUTTLE 3
K29	G-PROGRAM(VCR+)	G-PROGRAM(VCR+)	K73		
K30	JOG(+)	JOG(+)	K74		
K31	JOG(-)		K75		
K32		ENTER	K76		
K33	SHIFT(+)	SHIFT(+)	K77		
K34	SHIFT(-)	SHIFT(-)	K78		
K35	TRACKING(+)		K79		
K36	TRACKING(-)		K80	SHUTTLE 2	SHUTTLE 2
K37	DISPLAY	DISPLAY	K81		
K38	SLOW(+)	SLOW(+)	K82		
K39	SLOW(-)	SLOW(-)	K83		
K40	CLEAR(RESET)	CLEAR(RESET)	K84		
K41	RECORD	RECORD	K85		
K42	PAUSE/STILL	PAUSE/STILL	K86		
K43	AUTO TRACKING	AUTO TRACKING	K87	TEST	TEST
K44	EJECT	EJECT	K88	SHUTTLE 1	SHUTTLE 1

10-5. FUNCTION-TIMER (M472/M462/M45)

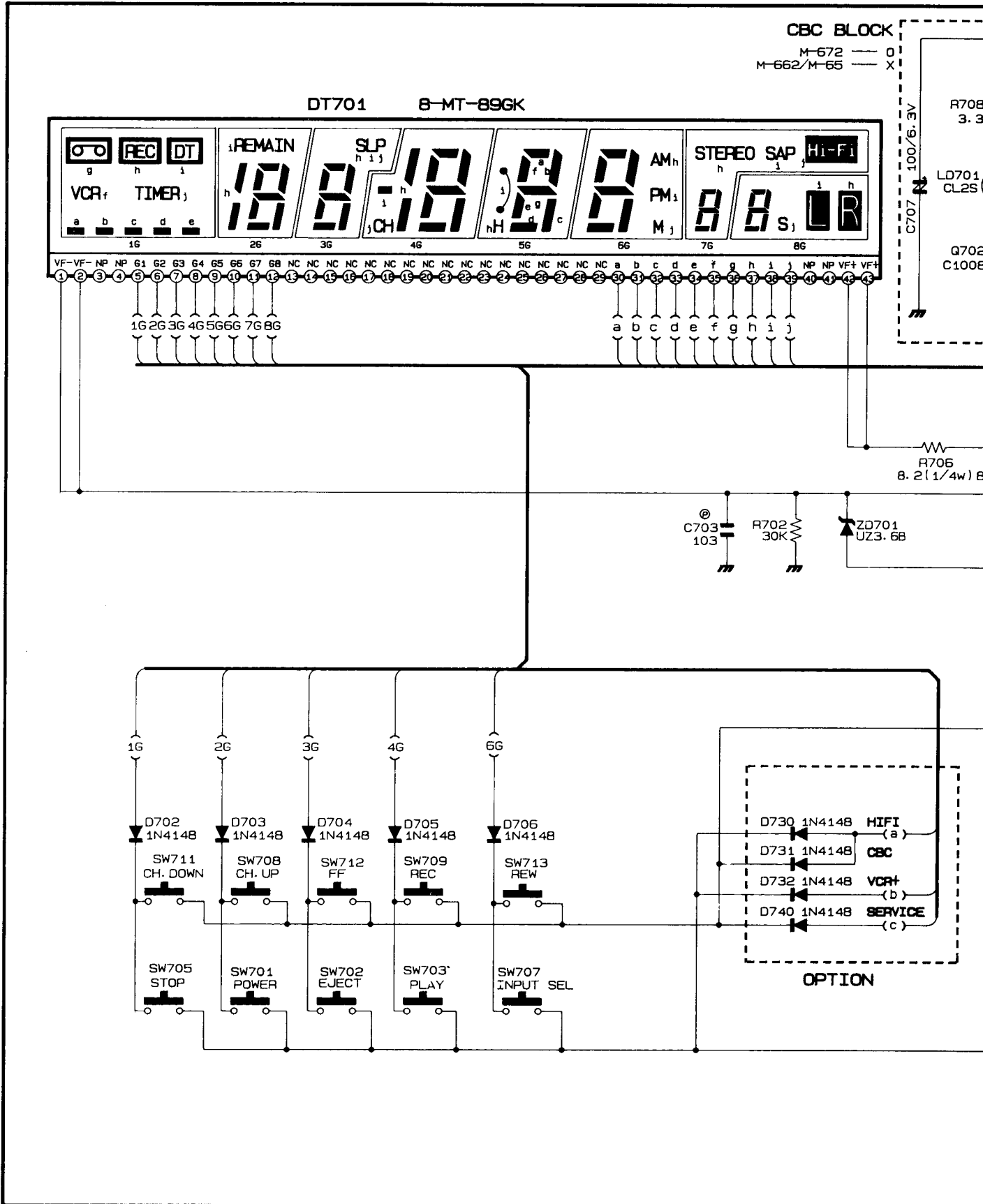

CBC BLOCK

M-672 — 0
M-662/M-65 — X

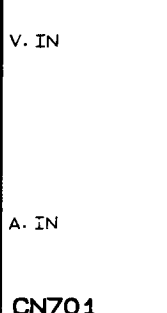
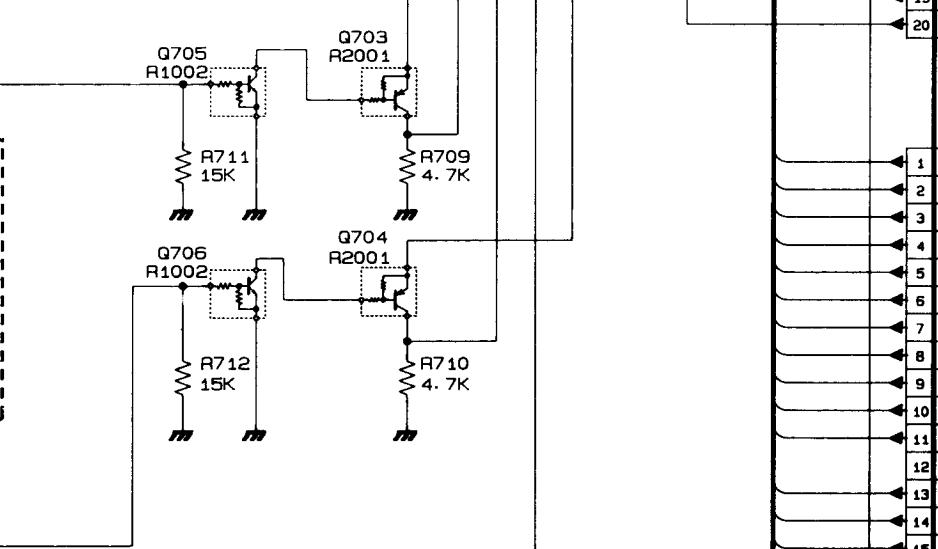
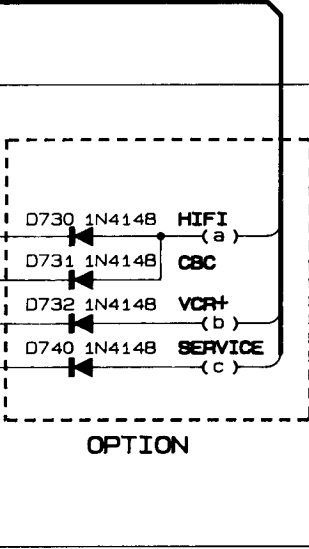
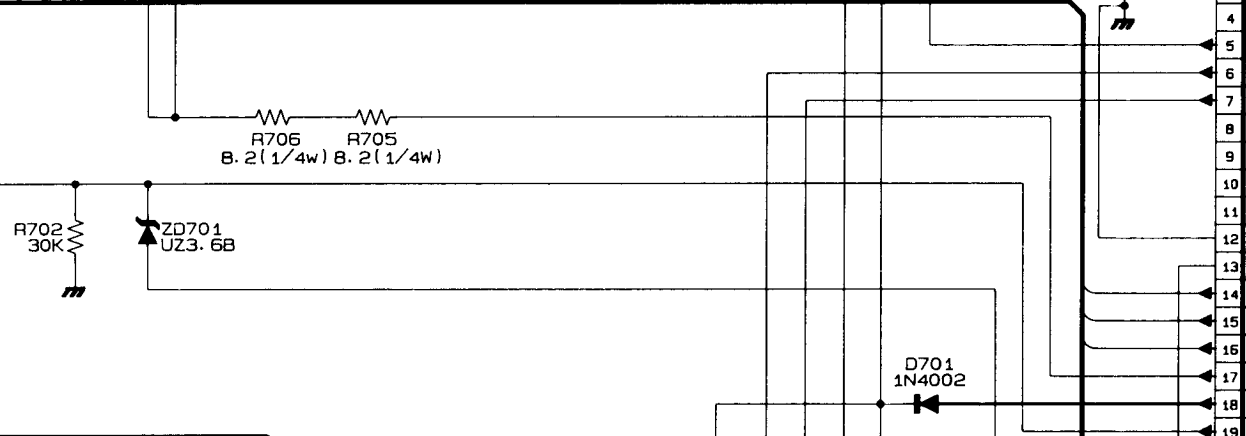
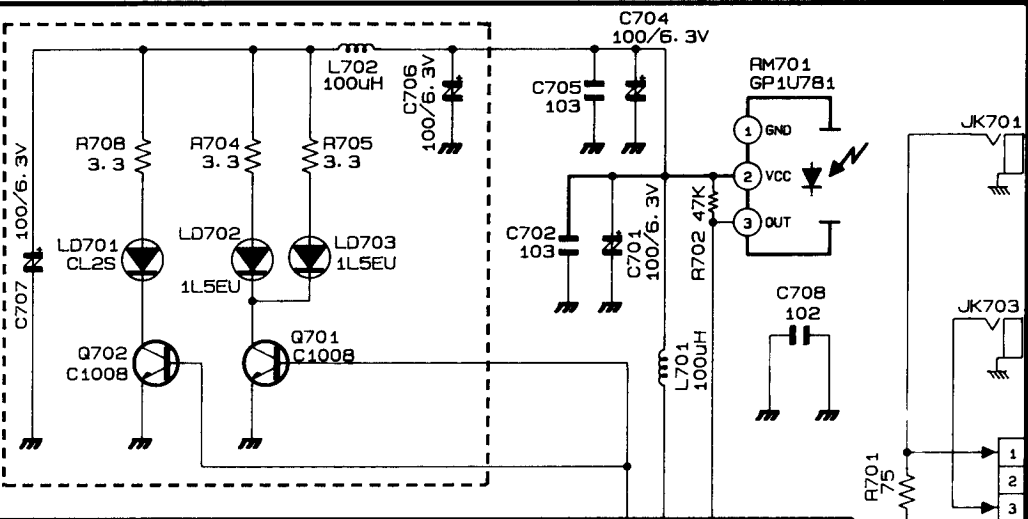
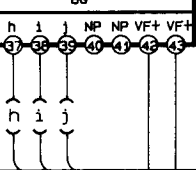
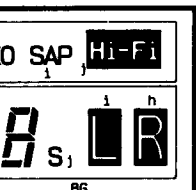

CN701

1	V. OUT	1
2	RESET	2
3	A. OUT	3
4	A. OUT L	4
5	REMOTE OUT	5
6	KEY IN 2	6
7	KEY IN 1	7
8	SHUTTLE	8
9	DATA OUT	9
10	DATA IN	10
11	CLK	11
12	JACK GND	12
13	GND	13
14	1G	14
15	2G	15
16	3G	16
17	VF+	17
18	AL5. 8V	18
19	VF-	19
20	-30V	20

FROM OR TO SYSCON (CN603)

CN702

1	4G	1
2	5G	2
3	6G	3
4	7G	4
5	8G	5
6	a	6
7	b	7
8	c	8
9	d	9
10	e	10
11	f	11
12	-30V	12
13	g	13
14	h	14
15	i	15
16	j	16
17	GND	17
18	GND	18
19	CBC IN	19
20	GND	20

FROM OR TO SYSCON (CN602)

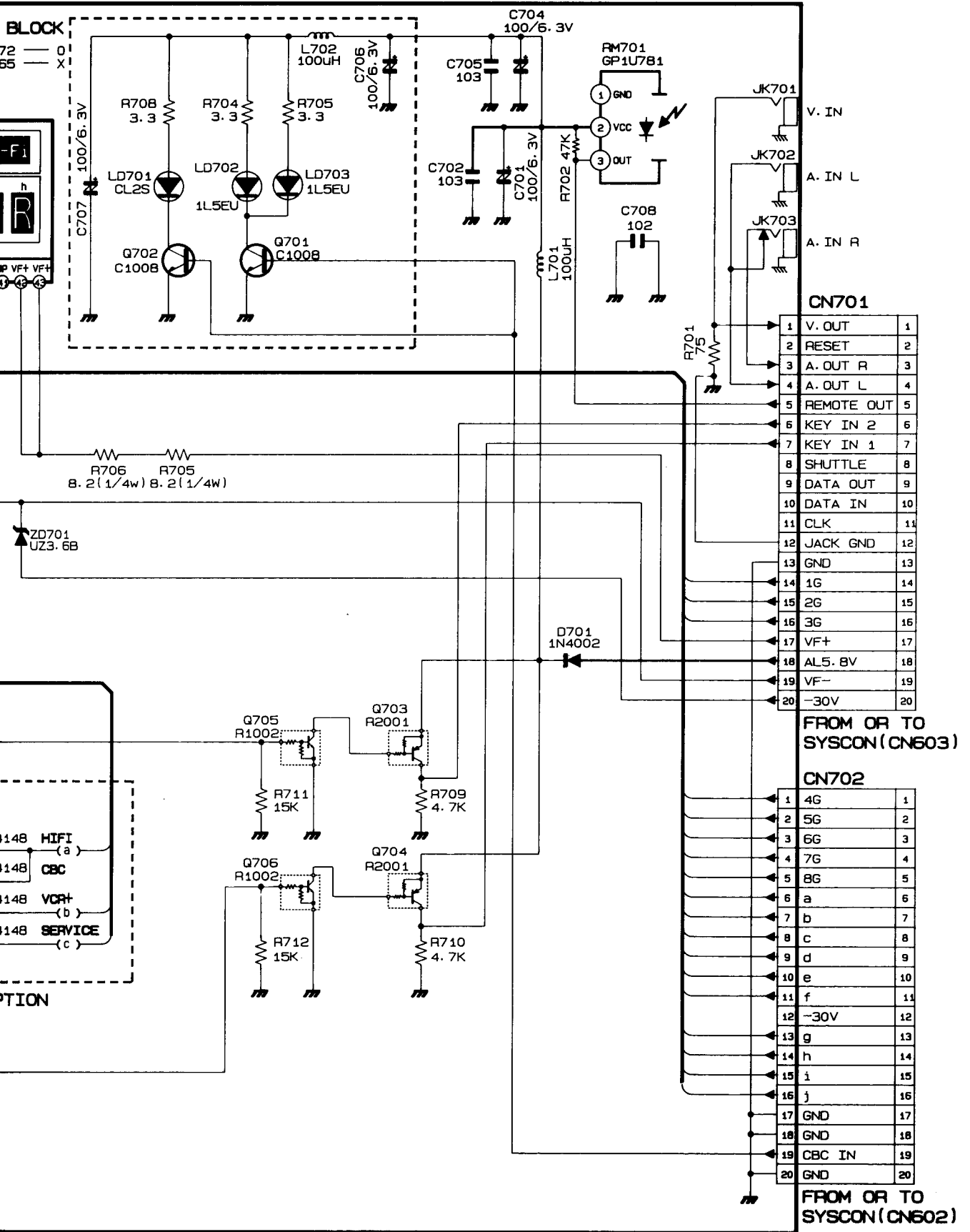

CN701

1	V. OUT	1
2	RESET	2
3	A. OUT R	3
4	A. OUT L	4
5	REMOTE OUT	5
6	KEY IN 2	6
7	KEY IN 1	7
8	SHUTTLE	8
9	DATA OUT	9
10	DATA IN	10
11	CLK	11
12	JACK GND	12
13	GND	13
14	1G	14
15	2G	15
16	3G	16
17	VF+	17
18	AL5.8V	18
19	VF-	19
20	-30V	20

FROM OR TO SYSCON (CN603)

CN702

1	4G	1
2	5G	2
3	6G	3
4	7G	4
5	8G	5
6	a	6
7	b	7
8	c	8
9	d	9
10	e	10
11	f	11
12	-30V	12
13	g	13
14	h	14
15	i	15
16	j	16
17	GND	17
18	GND	18
19	CBC IN	19
20	GND	20

FROM OR TO SYSCON (CN602)

10-6. F/TIMER (M672/M672C/M662/M662C/M65/M65C)

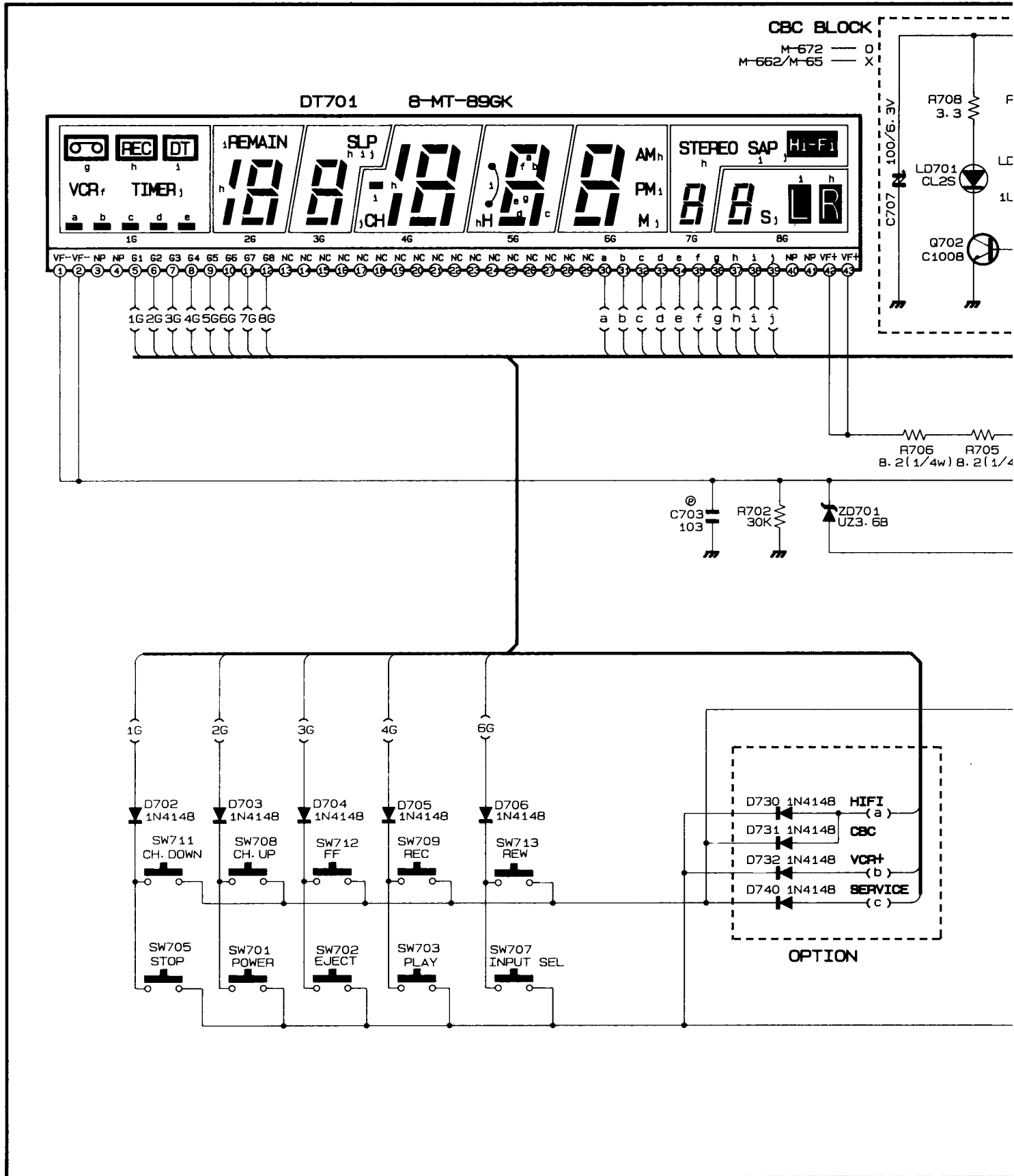

10-7. LINEAR AUDIO (M472/M462/M45)

RED ————— PB PROCESS
 - - - - - REC PROCESS

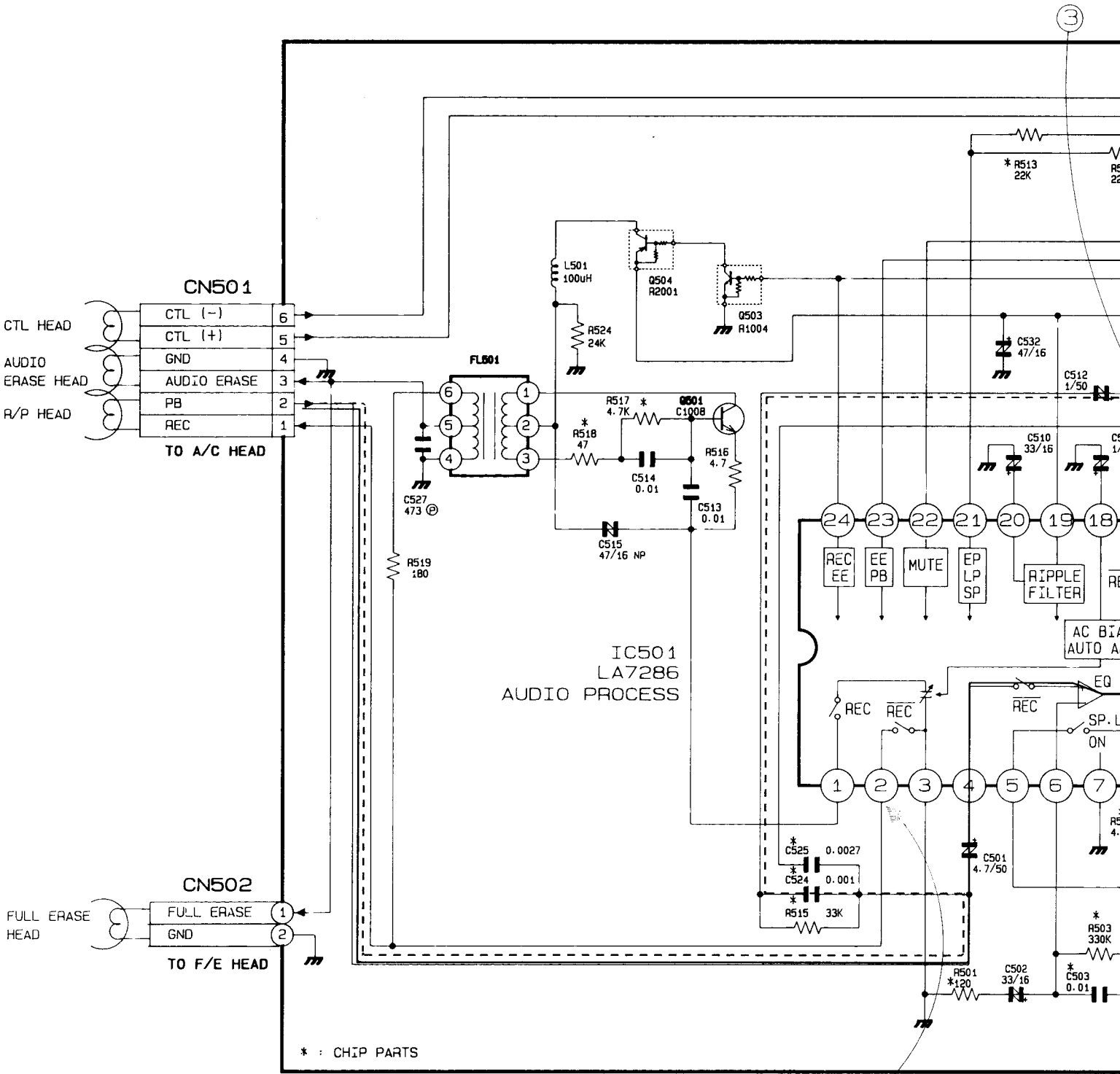

* : CHIP PARTS

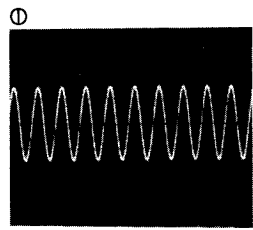
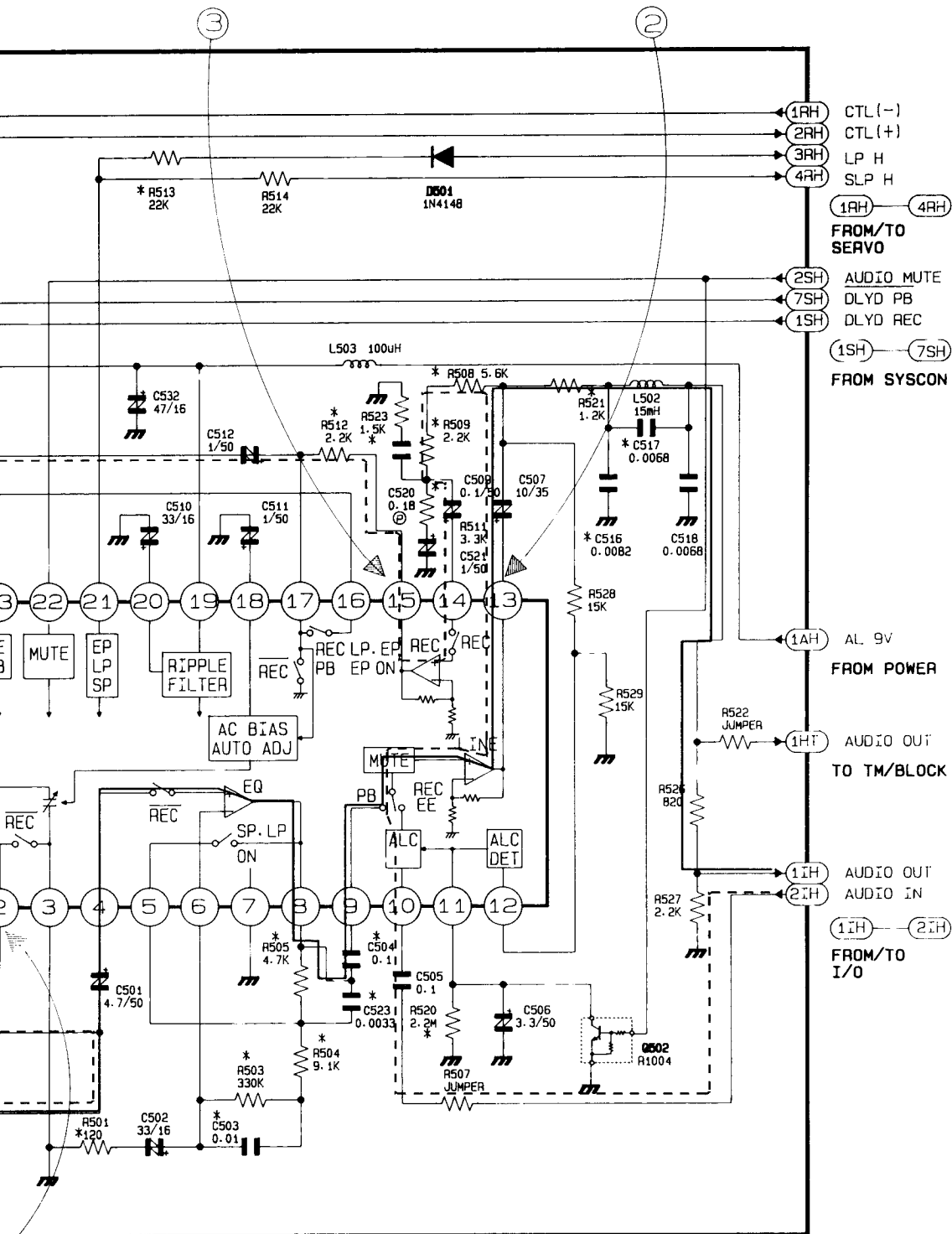

IC501-2
5.0Vp-p
REC

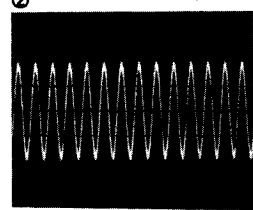

IC501-13
2.0Vp-p
PB/REC

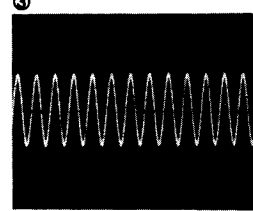

IC501-15
1.5Vp-p
PB/REC

1AH CTL (-)
2AH CTL (+)
3AH LP H
4AH SLP H

FROM/TO SERVO

2SH AUDIO MUTE
7SH DLYD PB
1SH DLYD REC

FROM SYSCON

1AH AL 9V
FROM POWER

1IH AUDIO OUT
TO TM/BLOCK

1IH AUDIO OUT
2IH AUDIO IN

FROM/TO I/O

MODE	STOP	REC	PLAY
IC501			
1	0	4.9	5.0
2	0	0	0
3	6.5	5.0	5.0
4	0	0	0
5	0	0.3	0.3
6	0	1.8	0.2
7	0	0	0
8	0	5.0	5.0
9	0	5.0	5.0
10	0.6	1.5	-0.3
11	0.2	4.6	4.6
12	4.5	0	0
13	-0.5	0	0
14	-5.0	4.9	0
15	-0.5	5.0	0
16	0	4.9	4.9
17	4.0	0	0
18	0	0	0
19	-0.5	0	0
20	5.1	5.0	5.0
21	-0.5	3.5	3.5
22	5.4	5.0	5.0
23	-0.5	1.9	2.2
24	2.4	4.9	5.3
Q501			
E	7.9	6.1	6.2
B	0.6	8.7	8.6
C	0.6	6.2	0.7
Q502			
E	0	0	0
B	4.8	0	0
C	0	1.7	0
Q503			
E	0	0	0
B	0	4.6	0
C	8.8	0	8.8
Q504			
E	8.8	8.8	8.8
B	8.8	0	8.8
C	0.6	8.7	0.6

10-8. TUNER

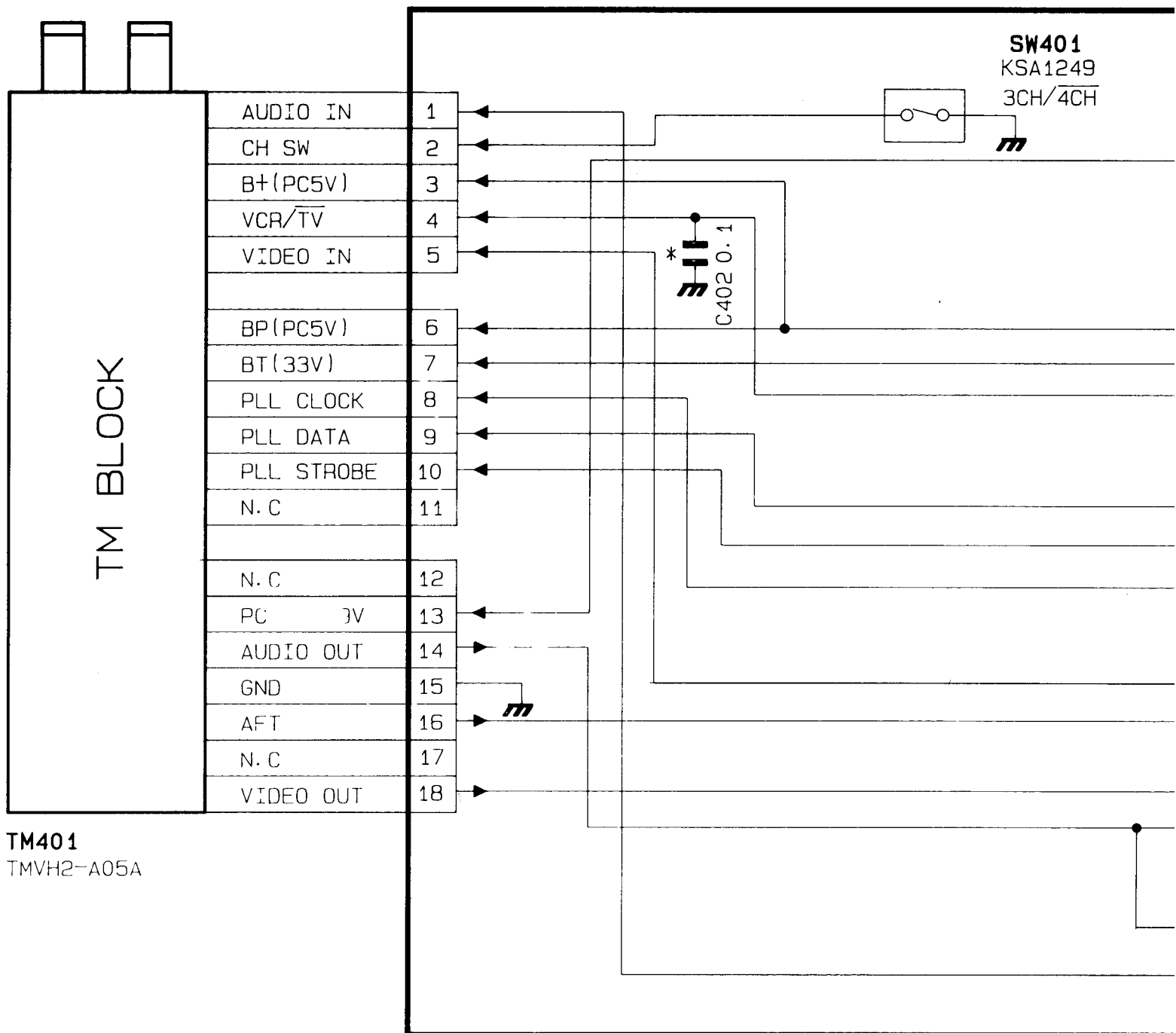

TM401
TMVH2-A05A

SW401
KSA1249
3CH/4CH

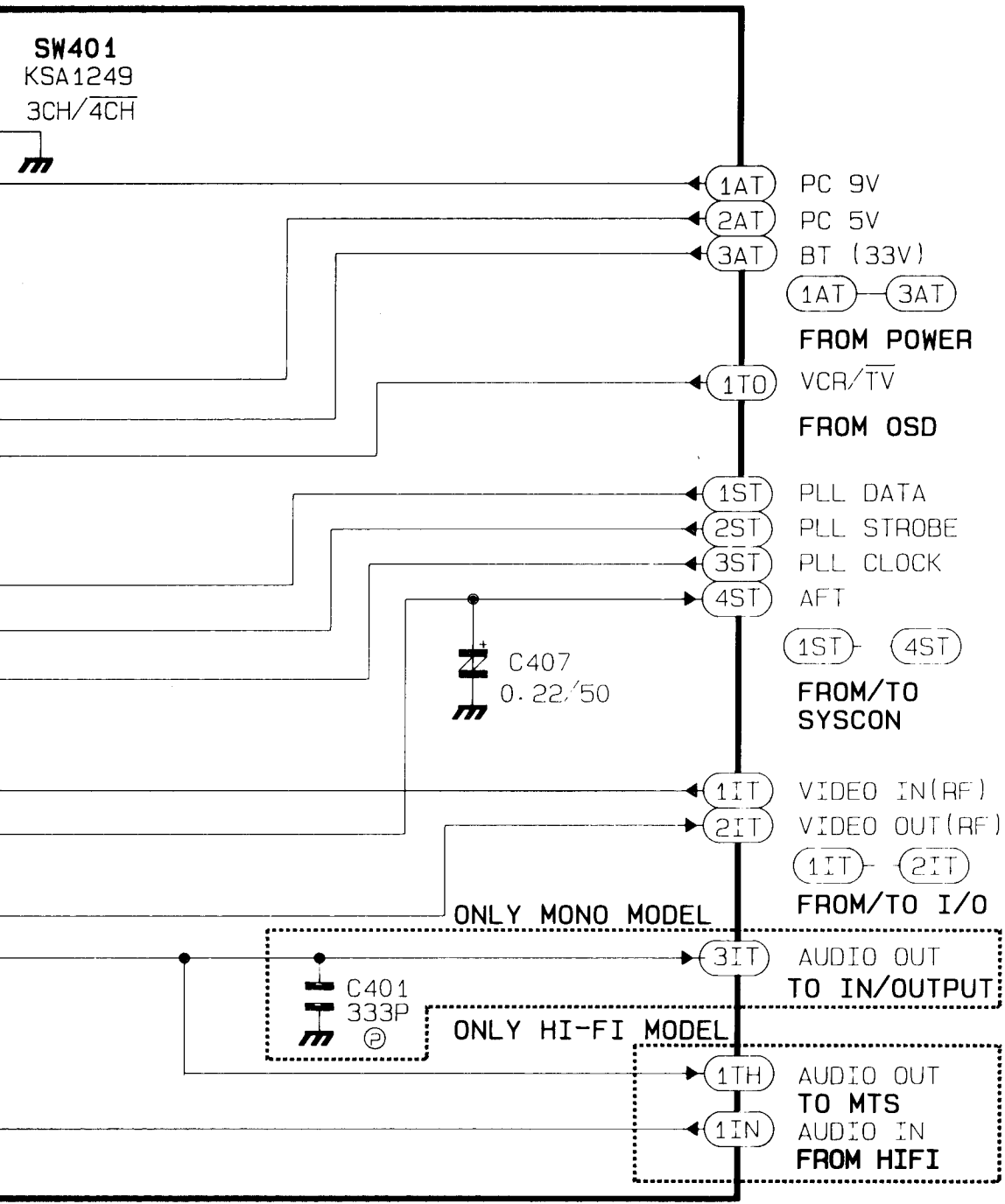

- 1AT PC 9V
- 2AT PC 5V
- 3AT BT (33V)
- (1AT) (3AT)
- FROM POWER**
- 1T0 VCR/TV
- FROM OSD**
- 1ST PLL DATA
- 2ST PLL STROBE
- 3ST PLL CLOCK
- 4ST AFT
- (1ST) (4ST)
- FROM/TO SYSCON**
- 1IT VIDEO IN(RF)
- 2IT VIDEO OUT(RF)
- (1IT) (2IT)
- FROM/TO I/O**
- 3IT AUDIO OUT TO IN/OUTPUT
- ONLY MONO MODEL**
- 1TH AUDIO OUT TO MTS
- 1IN AUDIO IN FROM HIFI
- ONLY HI-FI MODEL**

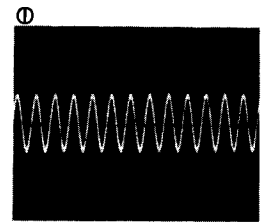

TM401-14
1.2Vp-p
REC

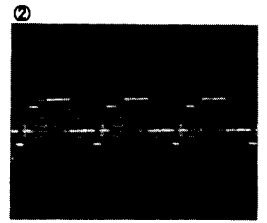

TM401-18
1.0Vp-p
REC

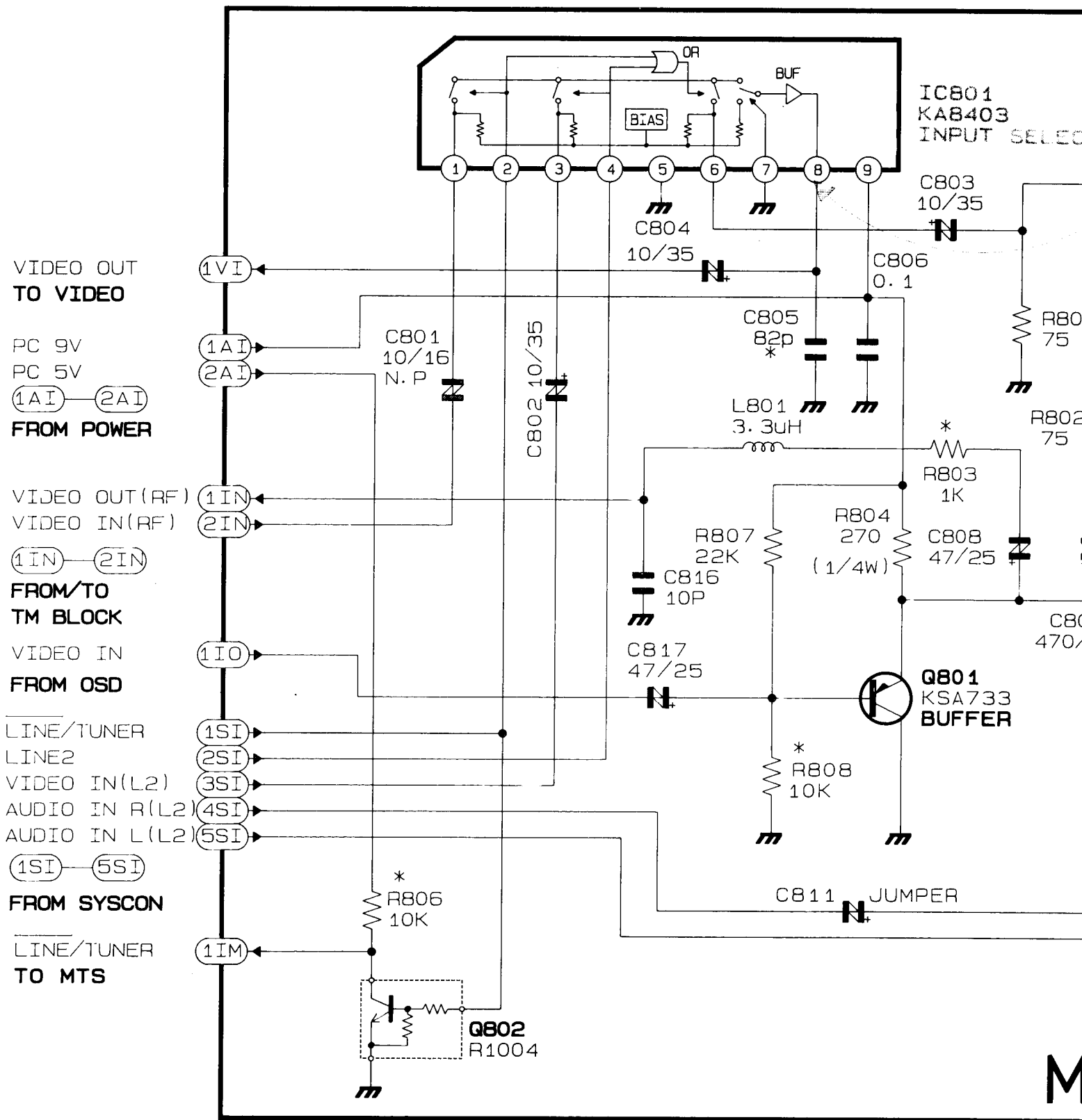

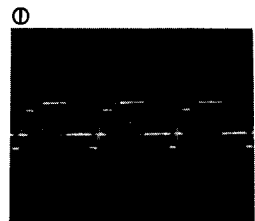
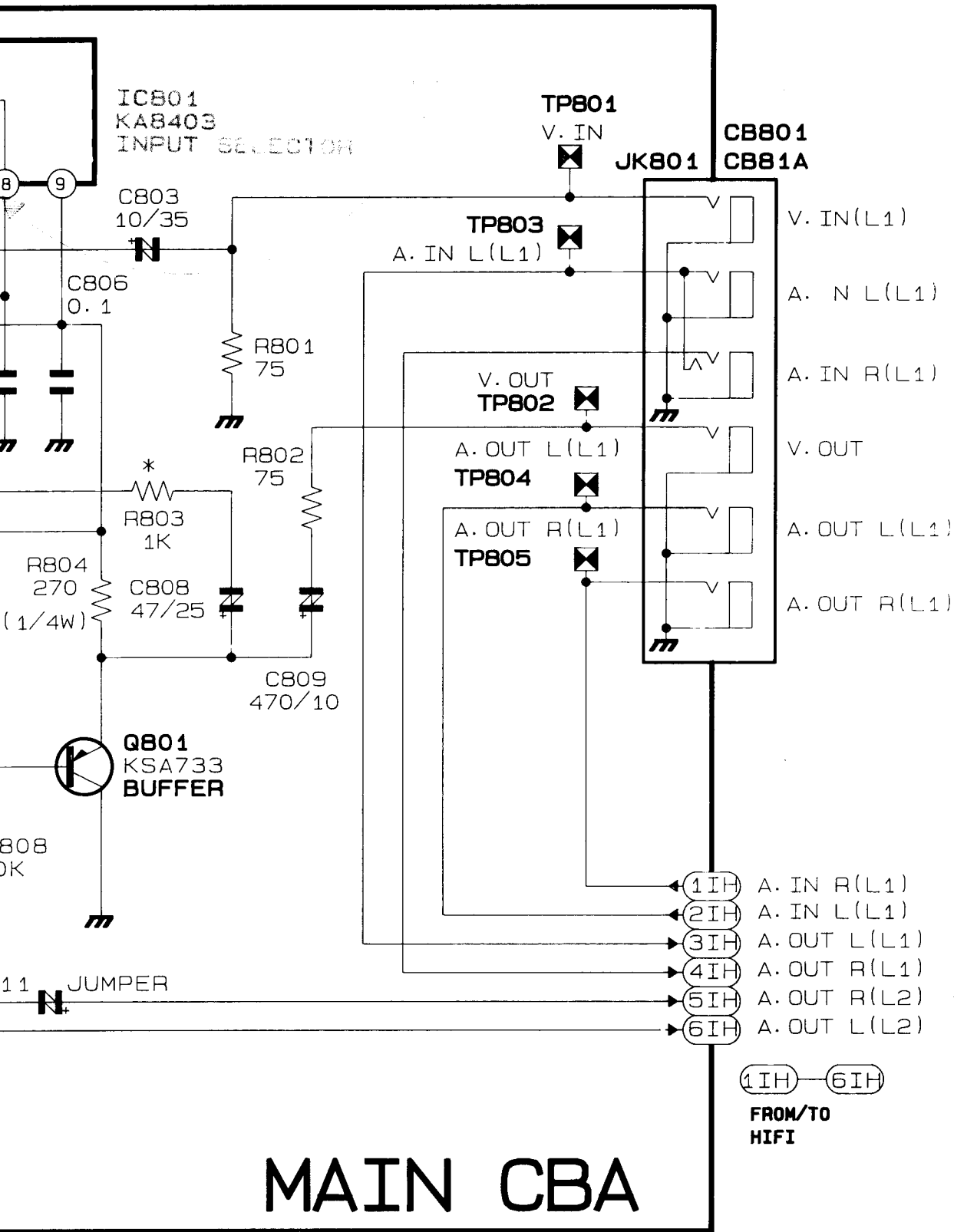

IC801-8
1.0Vp-p
REC

MODE	STOP	REC	PLAY
IC801			
1	6.1	6.1	6.1
2	4.6	0	0.9
3	6.1	6.1	6.1
4	0.8	0.8	4.5
5	0	0	0
6	6.1	6.1	6.1
7	0	0	0
8	5.3	5.3	5.3
9	8.9	8.9	8.9
Q801			
E	4.3	4.3	4.3
B	3.6	3.6	3.6
C	0	0	0

MAIN CBA

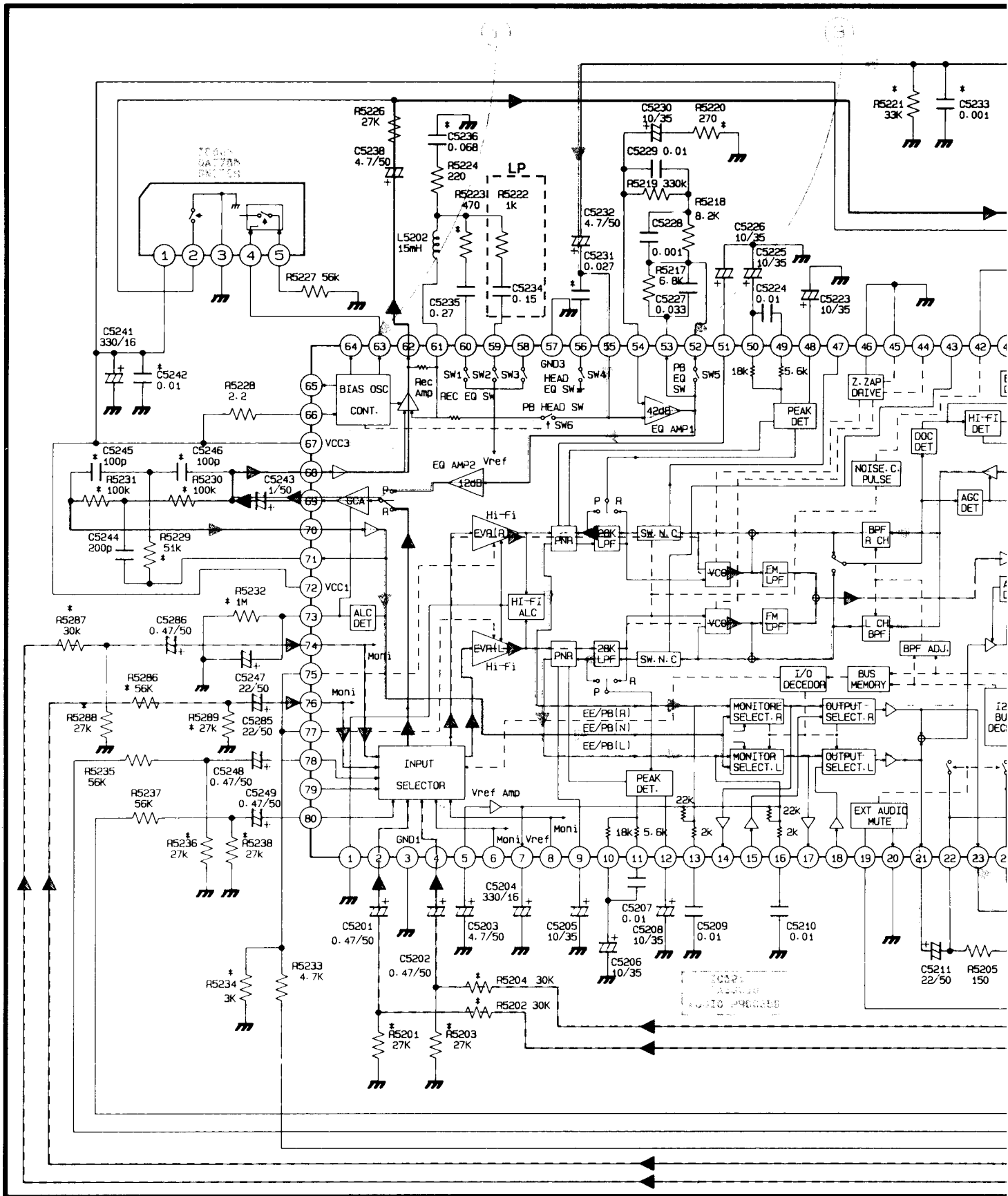

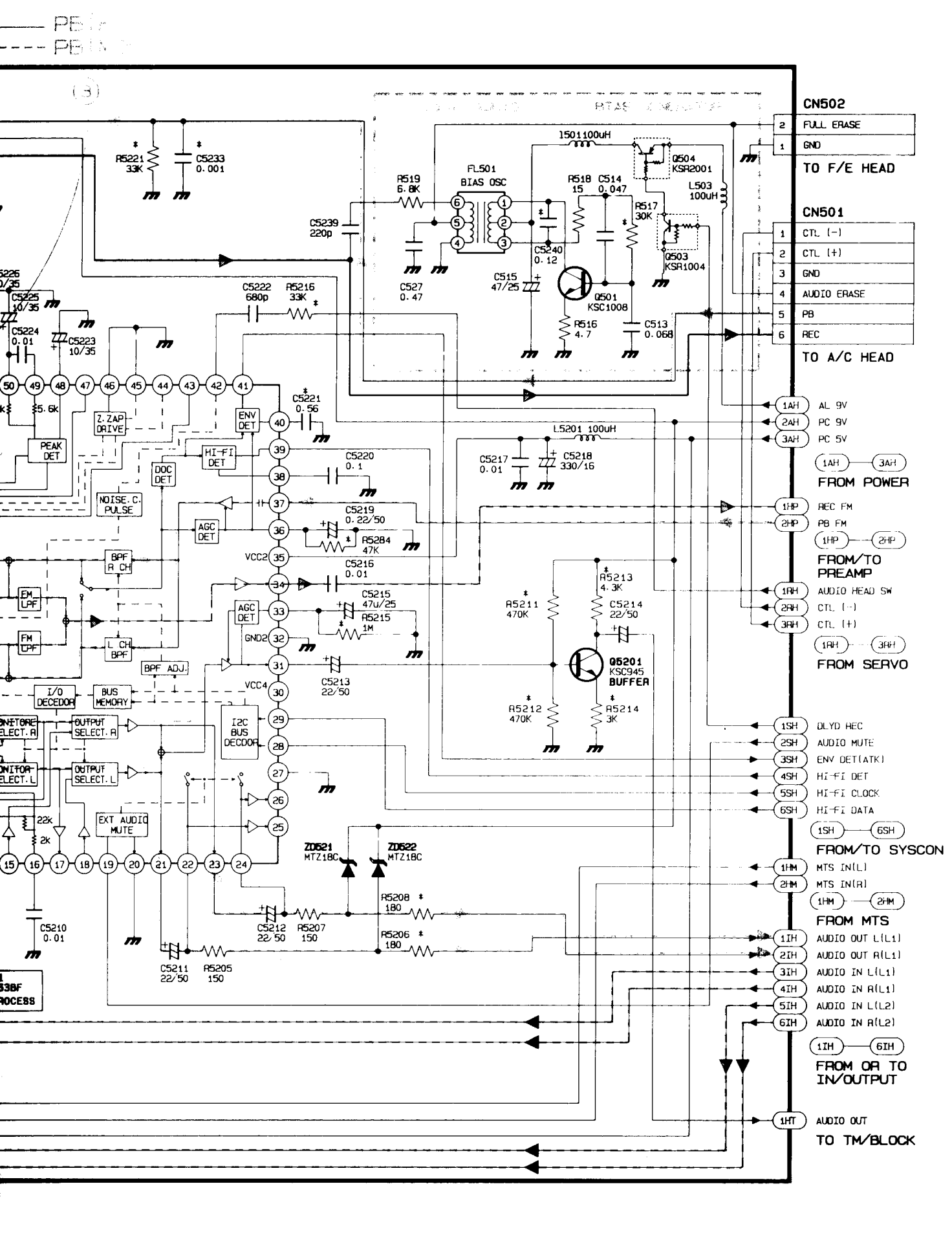

CN502

- 2 FULL ERASE
 - 1 GND
- TO F/E HEAD**

CN501

- 1 CTL (-)
- 2 CTL (+)
- 3 GND
- 4 AUDIO ERASE
- 5 PB
- 6 REC

TO A/C HEAD

- 1AH AL 9V
- 2AH PC 9V
- 3AH PC 5V

FROM POWER

- 1HP REC FM
- 2HP PB FM
- 1HP - 2HP

FROM/TO PREAMP

- 1RH AUDIO HEAD SW
- 2RH CTL (-)
- 3RH CTL (+)

FROM SERVO

- 1SH DLYD REC
- 2SH AUDIO MUTE
- 3SH ENV DET(ATK)
- 4SH HI-FI DET
- 5SH HI-FI CLOCK
- 6SH HI-FI DATA

FROM/TO SYSCON

- 1HM MTS IN(L)
- 2HM MTS IN(R)
- 1HM - 2HM

FROM MTS

- 1IH AUDIO OUT L(L1)
- 2IH AUDIO OUT R(L1)
- 3IH AUDIO IN L(L1)
- 4IH AUDIO IN R(L1)
- 5IH AUDIO IN L(L2)
- 6IH AUDIO IN R(L2)

FROM OR TO IN/OUTPUT

- 1HT AUDIO OUT
- TO TM/BLOCK**

①

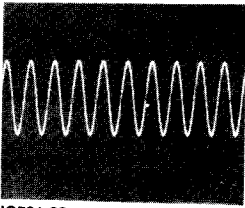

IC521-63
5.0Vp-p
REC

②

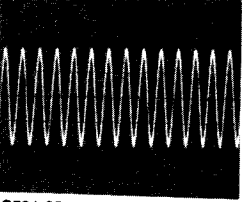

IC521-23
2.0Vp-p
PB/REC

③

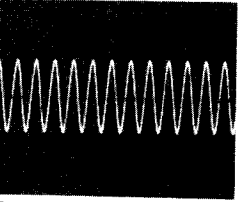

IC521-52
1.5Vp-p
PB/REC

MODE LOCA.NO	STOP	REC	PLAY
IC521			
1	0	0	0
2	4.4	4.4	4.4
3	0	0	0
4	4.4	4.4	4.4
5	4.4	4.4	4.4
6	4.4	4.4	4.4
7	4.4	4.4	4.4
8	4.4	4.4	4.4
9	4.4	4.4	4.4
10	4.4	4.4	4.4
11	4.4	4.4	4.4
12	0.9	0.4	0.9
13	4.4	4.4	4.4
14	4.4	4.4	4.4
15	4.4	4.4	4.4
16	4.4	4.4	4.4
17	4.4	4.4	4.4
18	4.4	4.4	4.4
19	0	0	0
20	0	0	0
21	4.4	4.4	4.4
22	0	0	0
23	4.4	4.4	4.4
24	0	0	0
25	3.8	3.0	3.8
26	3.7	3.0	3.7
27	0	0	0
28	4.2	4.2	4.2
29	4.0	4.0	4.0
30	2.0	2.0	2.0
31	4.4	4.4	4.4
32	0	0	0
33	1.1	0.6	1.1
34	0	0.3	2.3
35	5.0	5.0	5.0
36	0.3	1.6	0.9
37	0	0	0
38	0	0	0
39	0	0	0
40	0	3.7	0
41	0.1	3.7	0.1
42	4.4	4.4	4.4
43	2.3	4.4	2.3
44	4.4	4.4	4.4
45	0	0	0
46	0	0	0
47	4.4	4.4	4.4
48	0.8	0.8	0.8
49	4.4	4.4	4.4

MODE LOCA.NO	STOP	REC	PLAY
50	4.4	4.4	4.4
51	4.4	4.4	4.4
52	4.4	4.4	4.4
53	4.4	4.4	4.4
54	4.4	4.4	4.4
55	4.4	4.4	4.4
56	0	0	0
57	0	0	0
58	1.2	1.2	1.2
59	1.2	1.2	1.2
60	1.2	1.2	1.2
61	4.4	4.4	4.4
62	4.4	4.4	4.4
63	0	0	4.3
64	0	0	8.3
65	0	0	8.3
66	8.9	8.9	8.9
67	8.9	8.9	8.9
68	4.4	4.4	4.4
69	4.4	4.4	4.4
70	4.4	4.4	4.4
71	4.4	4.4	4.4
72	8.9	8.9	8.9
73	0.5	0	0.6
74	4.3	4.3	4.3
75	1.9	1.9	1.9
76	4.4	4.4	4.4
77	1.9	1.9	1.9
78	4.4	4.4	4.4
79	4.4	4.4	4.4
80	4.4	4.4	4.4
Q5201			
E	0.7	0.7	0.7
B	4.4	4.4	4.4
C	6.7	6.7	6.7

MODE LOCA.NO	STOP	REC	PLAY
IC521			
1	4.9	4.9	4.5
2	0	0	0.9
3	5.1	2.5	0
4	0	0	0
5	1.8	1.8	3.2
6	2.9	2.9	2.7
7	4.9	4.9	4.5
8	0	0	0
9	0	0	0
10	2.9	2.9	2.8
11	0.5	0.5	1.3
12	0.2	0.2	5.0
13	0	0	0.7
14	0	0	0.5
15	0	0	1.8
16	0	0	0
17	0.8	0.8	0
18	0.7	0.7	0
19	0	0	0
20	0.7	0.7	0
21	0.8	0.8	0
22	0	0	0
23	0	0	3.8
24	0	0	3.8

IC521 TA8863AF

FULL ERASE
 BIAS ERROR DAT.
 VCC 3
 NORMAL AUDIO REC INV. AMP. IN
 NORMAL AUDIO ALC/GCA OUT
 NORMAL AUDIO OUTPUT SW IN
 NORMAL AUDIO FH TRAP OUT
 VCC 1
 NORMAL AUDIO ALC FILTER
 LINE 2 (R) IN
 HI-FI (R-CH) REC LEVEL ADJ.
 LINE 2 (L) IN
 HI-FI (L-CH) REC BIAS ADJ.
 TV (R) IN
 SAP IN
 TV (L) IN

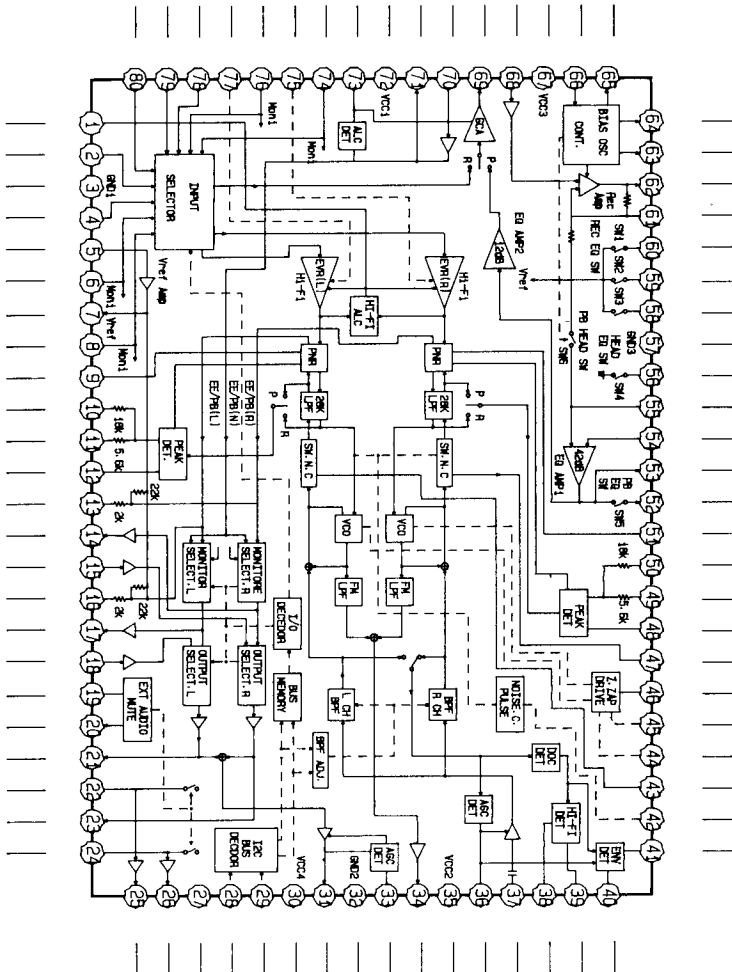

ALC FILTER
 LINE. 1(R) IN
 GND 1
 LINE. 1(L) IN
 VREF FILTER
 LINE. 3(R) IN
 VREF OUT
 LINE. 3(L) IN
 DC.F.B (L)
 WEIGHTING FILTER. 1(L)
 WEIGHTING FILTER. 2 (L)
 PEAK DET. FILTER (L)
 NR EMPH. FILTER (R)
 EXT. (R) OUT
 EXT. (R) IN
 NR EMPH. FILTER (L)
 EXT. (L) OUT
 NR EMPH. FILTER (L)
 AUX MUTE
 EXT. IN CONT.
 LINE (L) OUT
 LINE (L) MUTE
 LINE (R) OUT
 LINE (R) MUTE

REC OSC BIAS
 NORMAL AUDIO HEAD SW. CONT.
 NORMAL AUDIO REC AMP OUT
 NORMAL AUDIO REC AMP IN(-)
 REC EQ SW. 1
 REC EQ SW. 2
 REC EQ SW. 3
 GND 3
 HEAD EQ SWITCH
 EQ AMP 1 IN(+)
 EQ AMP 1 IN(-)
 EQ AMP 1 OUT. 2
 EQ AMP 1 OUT. 1
 DC.F.B (R)
 WEIGHTING FILTER. 1 (R)
 WEIGHTING FILTER. 2 (R)
 PEAK DET. FILTER (R)
 REC PNR (R) OUT MONITER
 ZENER ZAP (R) PLUSE IN
 ZENER ZAP (L) PLUSE IN
 REC PNR(L) OUT MONITER
 FM MOD. MONITER CONT.
 SWITCHING PLUSE IN
 TRACKING OUT

ENVELOPE OUT
 HI-FI DET. OUT
 HI-FI DET. FILTER
 DROP OUT DET. FILTER
 PB FM IN
 PB FM AGC FILTER
 VCC 2
 FM OUT
 MONO ALC FILTER
 GND 2
 MONAURAL OUT
 VCC 4
 SERIAL DATA IN
 SERIAL CLOCK IN
 GND 4
 LOG AMP. (R) OUT
 LOG AMP. (L) OUT

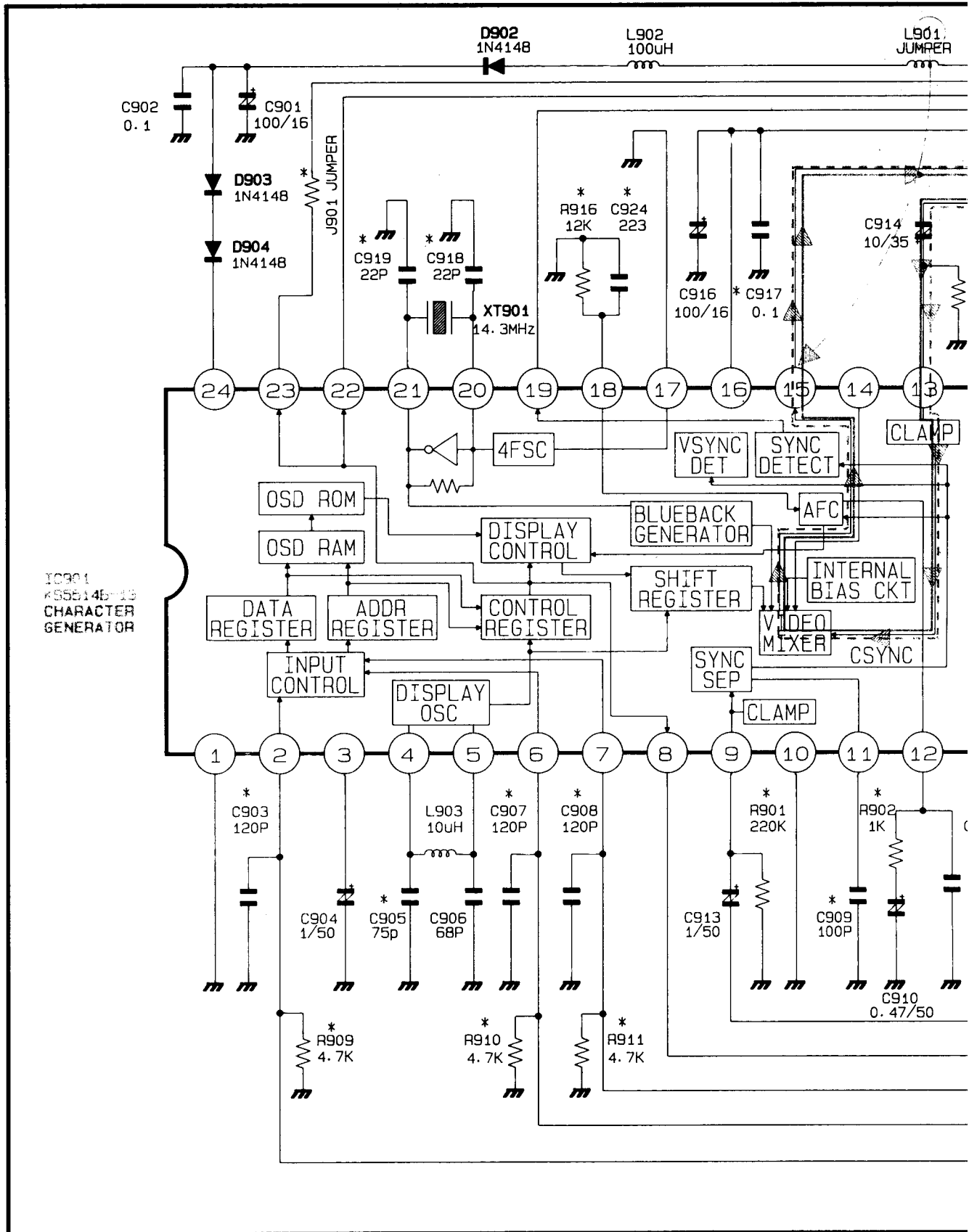

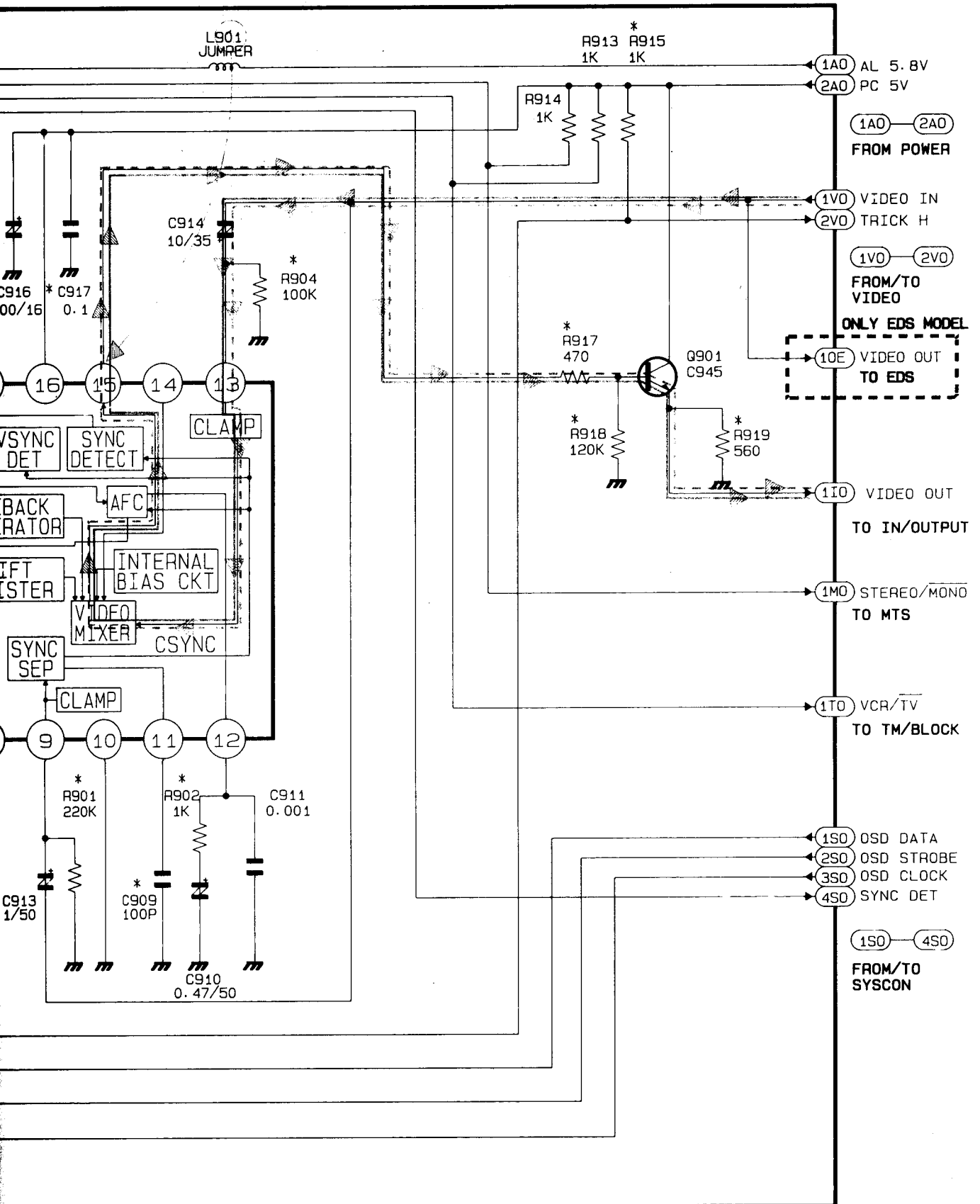

①

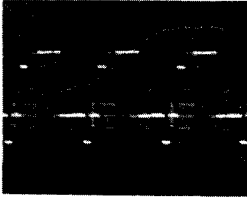

IC901-15
2.0Vp-p
PB/REC

MODE LOCA.NO	STOP	REC	PLAY
IC901			
1	0	0	0
2	4.0	4.0	4.0
3	3.9	3.9	3.9
4	1.7	1.7	1.7
5	1.5	1.5	1.5
6	3.9	3.9	3.9
7	0	0	0
8	0.8	0.8	0.8
9	1.7	1.7	2.5
10	0	0	0
11	1.9	1.9	2.7
12	2.7	2.7	2.7
13	1.6	1.6	2.4
14	2.0	2.3	2.0
15	0.8	3.1	3.4
16	5.0	5.0	5.0
17	0	0	0
18	0.7	0.7	0.7
19	0	0	4.9
20	1.6	1.6	1.6
21	1.9	1.9	1.9
22	4.1	4.1	0.8
23	0.8	0.8	0.8
24	3.9	3.9	3.9
Q901			
E	2.3	2.4	2.2
B	3.0	3.0	3.0
C	5.0	5.0	5.0

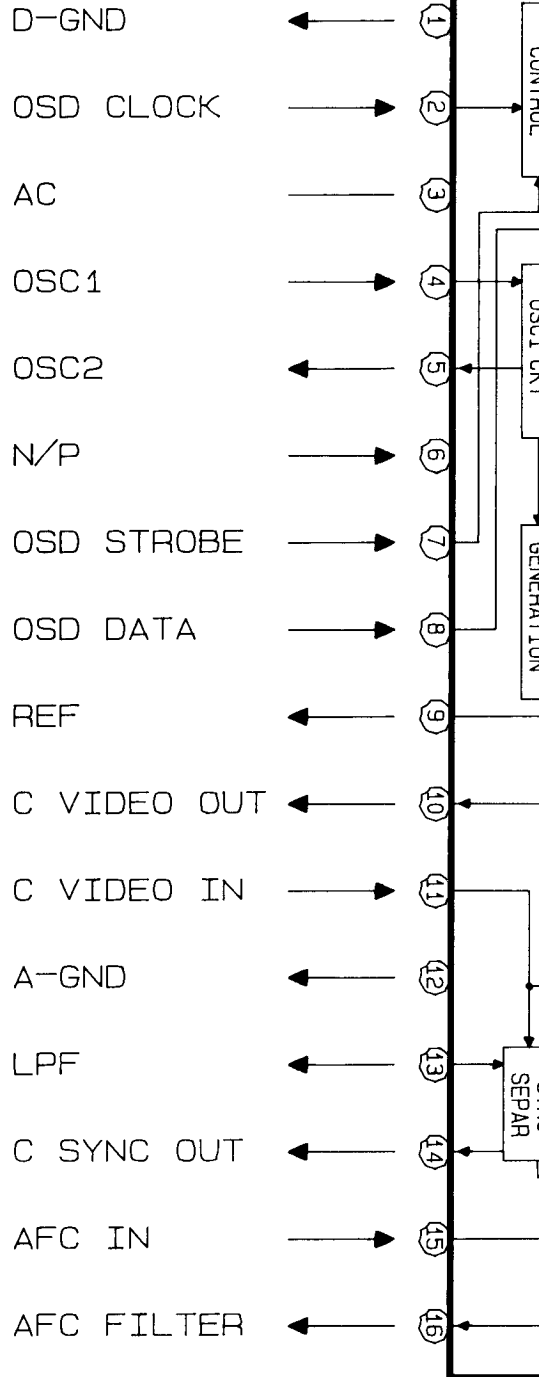

IC901 KS5514B-13

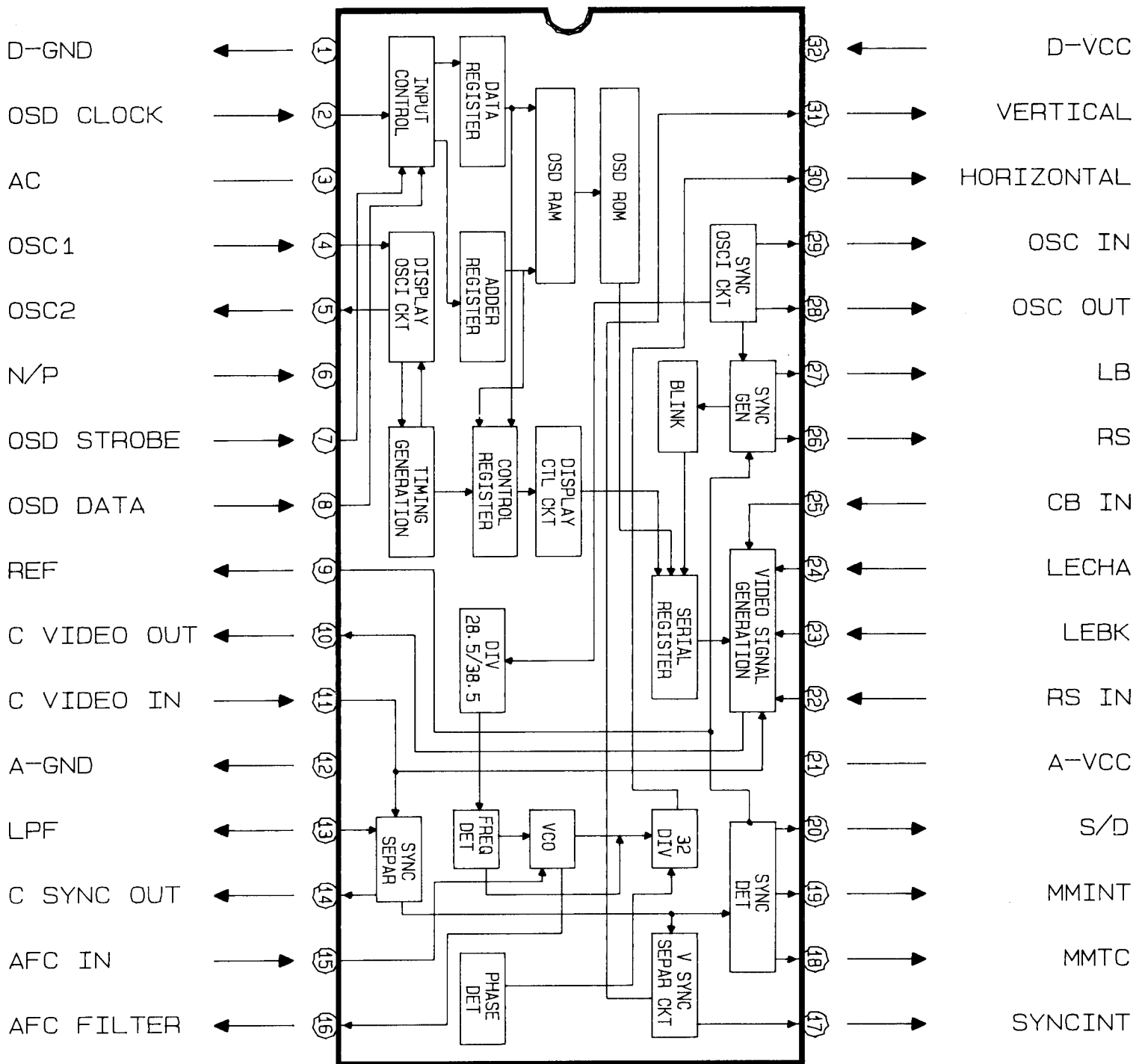

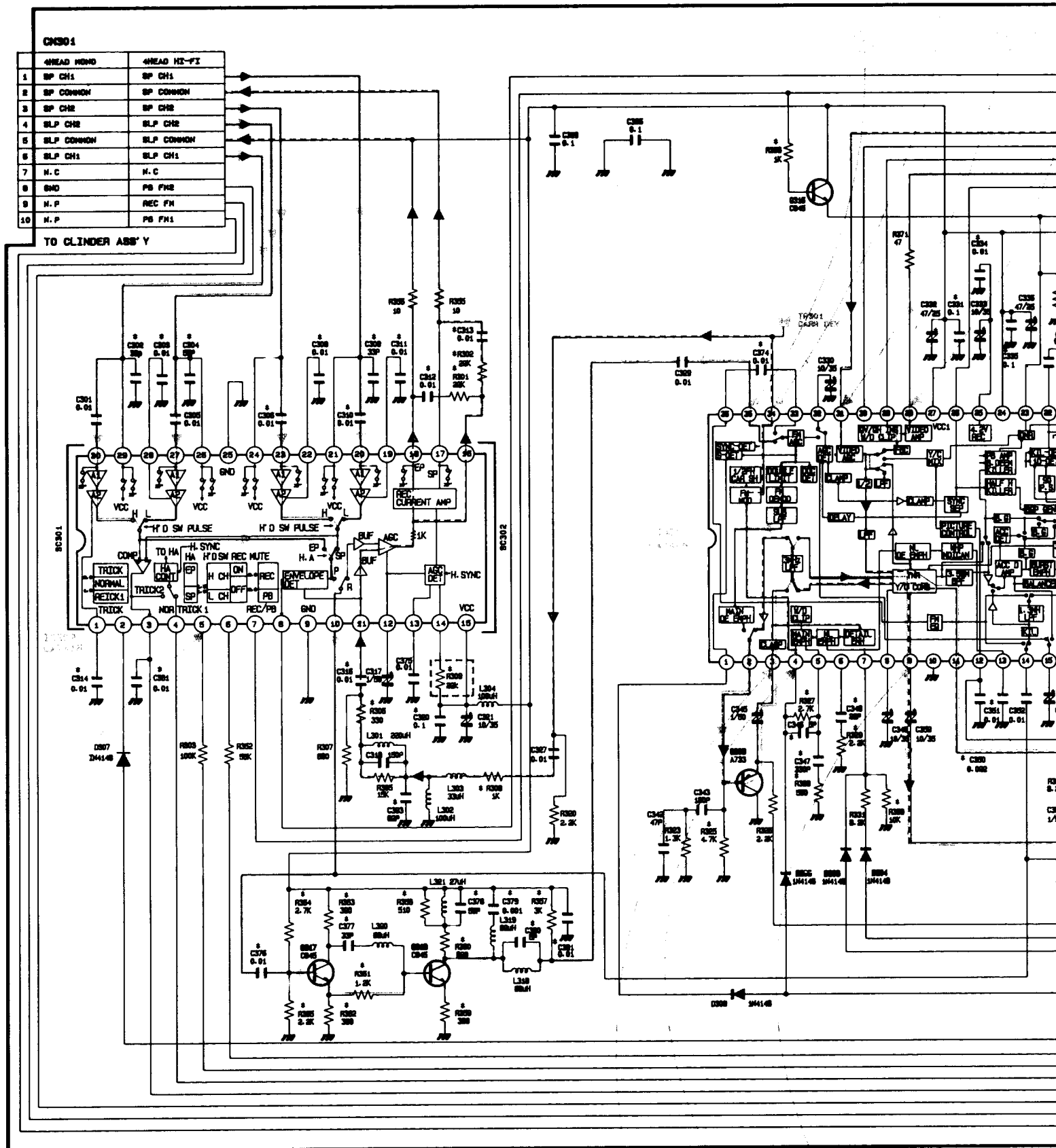

NOTICE
 MARK - OMP PARTS
 R300 - NI-F1 - 2K
 R300 - NI-F1 - 1.5K

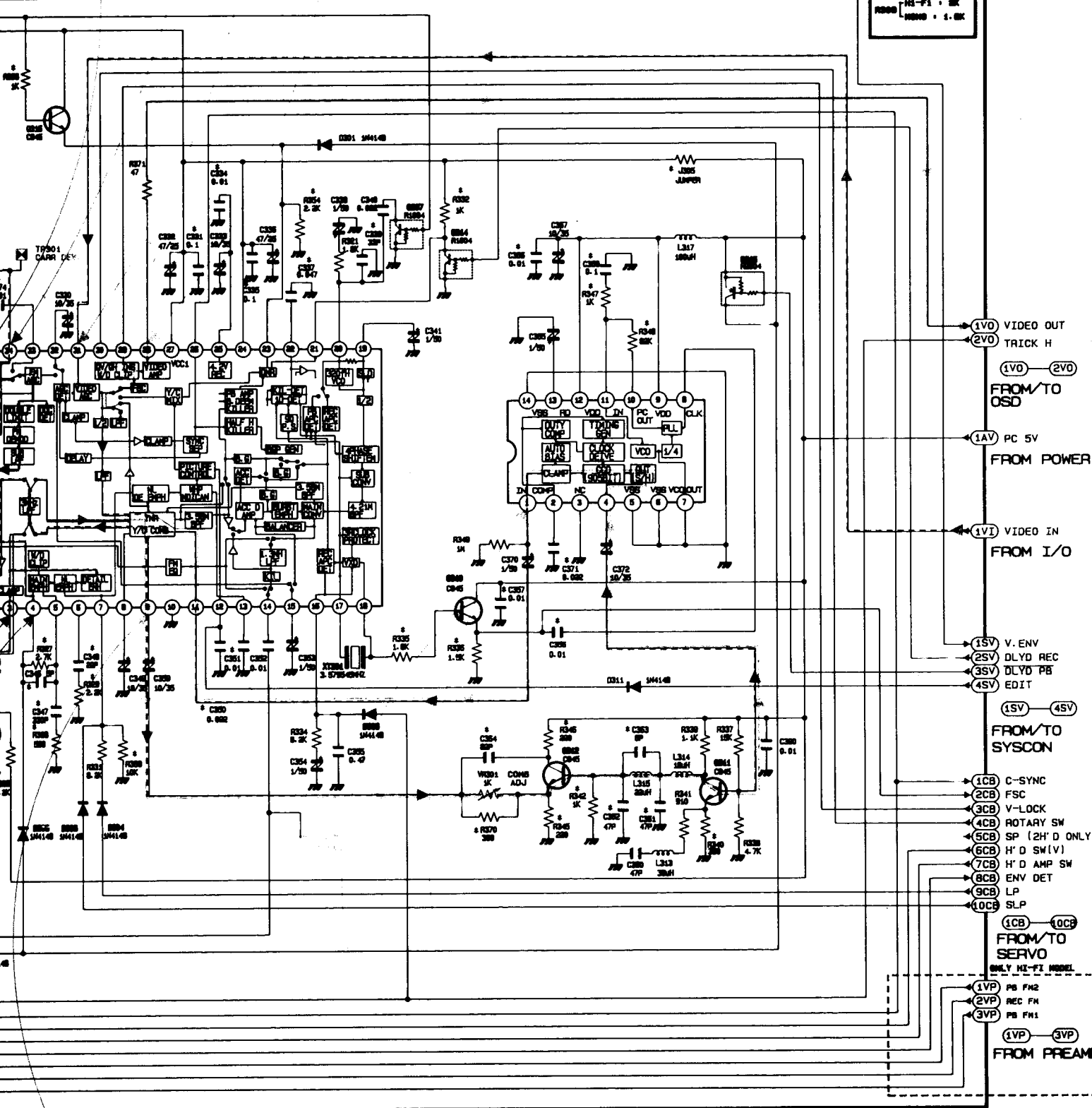

- 1V0 VIDEO OUT
- 2V0 TRICK H
- 1V0 - 2V0 FROM/TO OSD
- 1AV PC 5V
- FROM POWER
- 1VI VIDEO IN
- FROM I/O
- 1SV V. ENV
- 2SV DLYD REC
- 3SV DLYD PB
- 4SV EDIT
- 1SV - 4SV FROM/TO SYSCON
- 1CB C-SYNC
- 2CB FSC
- 3CB V-LOCK
- 4CB ROTARY SW
- 5CB SP (2H'D ONLY)
- 6CB H'D SW (V)
- 7CB H'D AMP SW
- 8CB ENV DET
- 9CB LP
- 10CB SLP
- 1CB - 10CB FROM/TO SERVO
- ONLY NI-F1 MODEL
- 1VP PB FN2
- 2VP REC FN
- 3VP PB FN1
- 1VP - 3VP FROM PREAMP

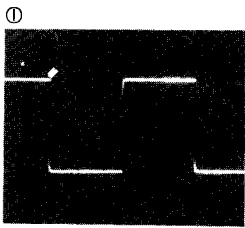

IC302-5
5.0Vp-p
PB/REC

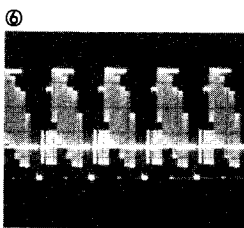

IC301-28
2.0Vp-p
PB/REC

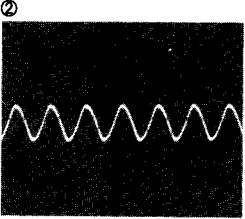

Q310-Base
3.0Vp-p
PB/REC

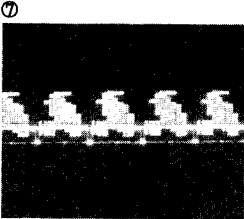

IC301-31
1Vp-p
PB/REC

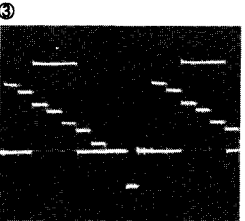

IC301-3
0.45Vp-p
PB/REC

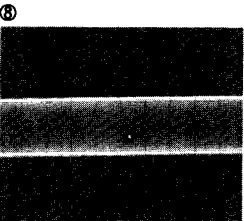

IC301-34
1.0Vp-p
REC

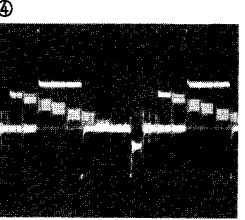

IC301-4
0.5Vp-p
REC

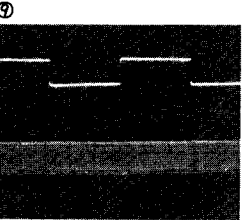

IC301-35
0.3Vp-p
PB

TP202
5.0Vp-p
PB

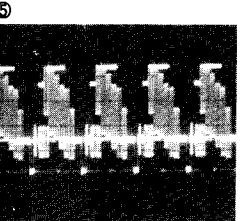

IC301-9
0.38Vp-p
PB/REC

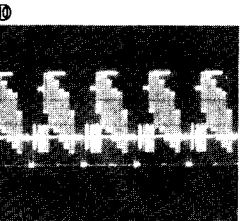

IC303-1
0.3Vp-p
PB/REC

MODE LOCA.NO	STOP	REC	PLAY
IC301			
1	3.0	3.0	4.3
2	2.0	2.0	2.9
3	2.9	2.9	2.9
4	2.1	2.1	4.2
5	2.1	2.1	4.2
6	2.8	2.8	2.8
7	0.5	4.4	4.4
8	2.4	2.4	2.4
9	2.0	2.0	2.0
10	0	0	0
11	1.0	1.0	1.0
12	2.4	2.4	2.4
13	2.4	2.4	2.4
14	2.2	2.2	3.0
15	2.2	2.2	2.2
16	2.0	2.0	2.0
17	3.7	3.7	3.7
18	2.5	2.5	2.5
19	2.7	2.7	2.7
20	2.6	2.6	2.6
21	3.2	0	3.2
22	2.7	2.0	2.5
23	0.8	3.9	4.0
24	4.8	4.8	4.8
25	4.0	4.0	4.0
26	0.6	0.7	0.2
27	4.8	4.8	4.8
28	0.7	0.8	2.7
29	0	0	0
30	2.5	2.5	2.5
31	2.9	2.9	3.7
32	1.5	1.5	1.5
33	1.1	1.1	0.2
34	3.0	3.0	3.4
35	0	0	3.5
36	3.3	2.4	0.7
IC302			
1	2.0	3.6	2.0
2	2.0	2.2	2.0
3	3.0	2.8	2.7
4	0.6	4.6	4.6
5	1.0	1.0	1.0
6	0.5	0.5	0.5
7	0	4.6	0
8	0.5	0.3	2.1
9	0	0	0
10	2.2	4.0	2.2
11	5.4	3.5	3.4
12	3.5	1.5	2.7

MODE LOCA.NO	STOP	REC	PLAY
13	3.3	2.5	2.5
14	5.0	3.8	5.0
15	5.0	5.0	5.0
16	0	1.6	2.0
17	0	0	0
18	0	3.8	0
19	2.0	3.6	2.0
20	0.6	0.6	0.6
21	0	0	0
22	2.0	3.6	2.0
23	0.6	0.6	0.6
24	0	0	0
25	0	0	0
26	0	4.0	0
27	0.6	0.1	0.6
28	2.0	3.6	2.0
29	0	4.0	0
30	0.6	0	0.6
Q307			
E	0	0	0
B	0	4.6	0
C	0.2	0	0.3
Q310			
E	1.9	1.9	1.9
B	5.0	5.0	5.0
C	2.4	2.4	2.4
Q311			
E	0.5	0.5	0.5
B	1.6	1.6	1.6
C	1.1	1.1	1.1
Q312			
E	0.9	0.9	0.9
B	4.3	4.3	4.3
C	1.7	1.7	1.7
Q314			
E	0	0	0
B	0	4.6	0
C	3.2	0	0

IC301 LA7425

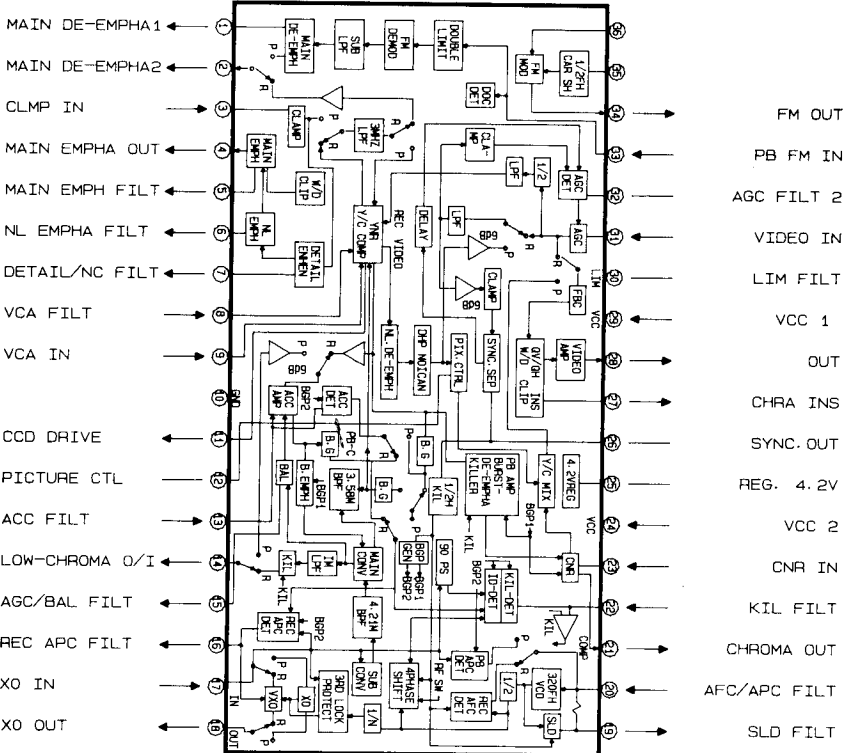

IC302 LA7416

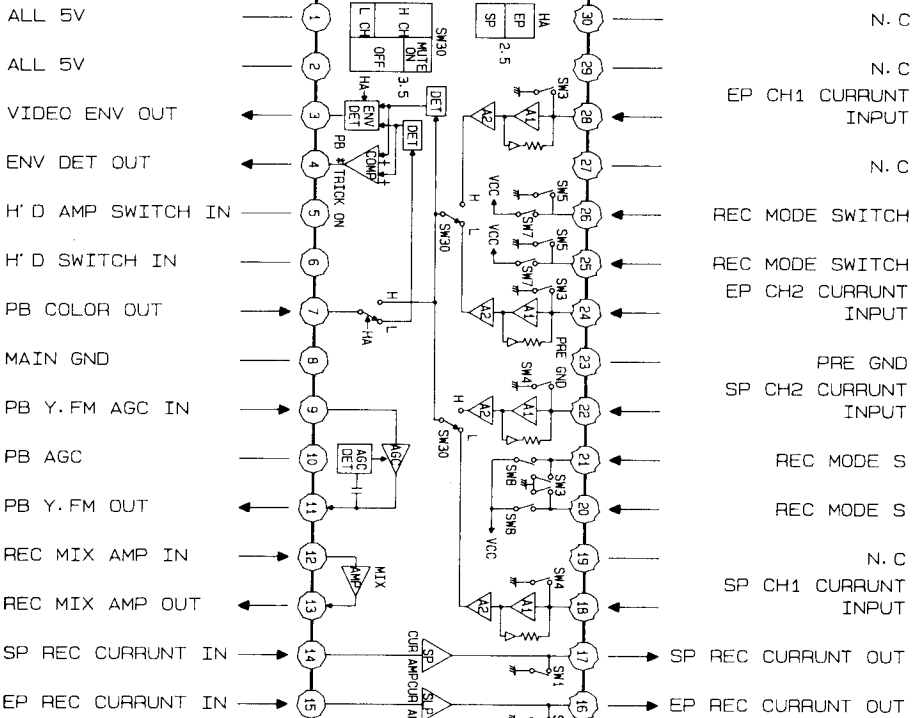

RED _____ CYLINDER SPEED CONTROL
 BLUE _____ CYLINDER PHASE CONTROL

BLUE _____

10-13. SERVO

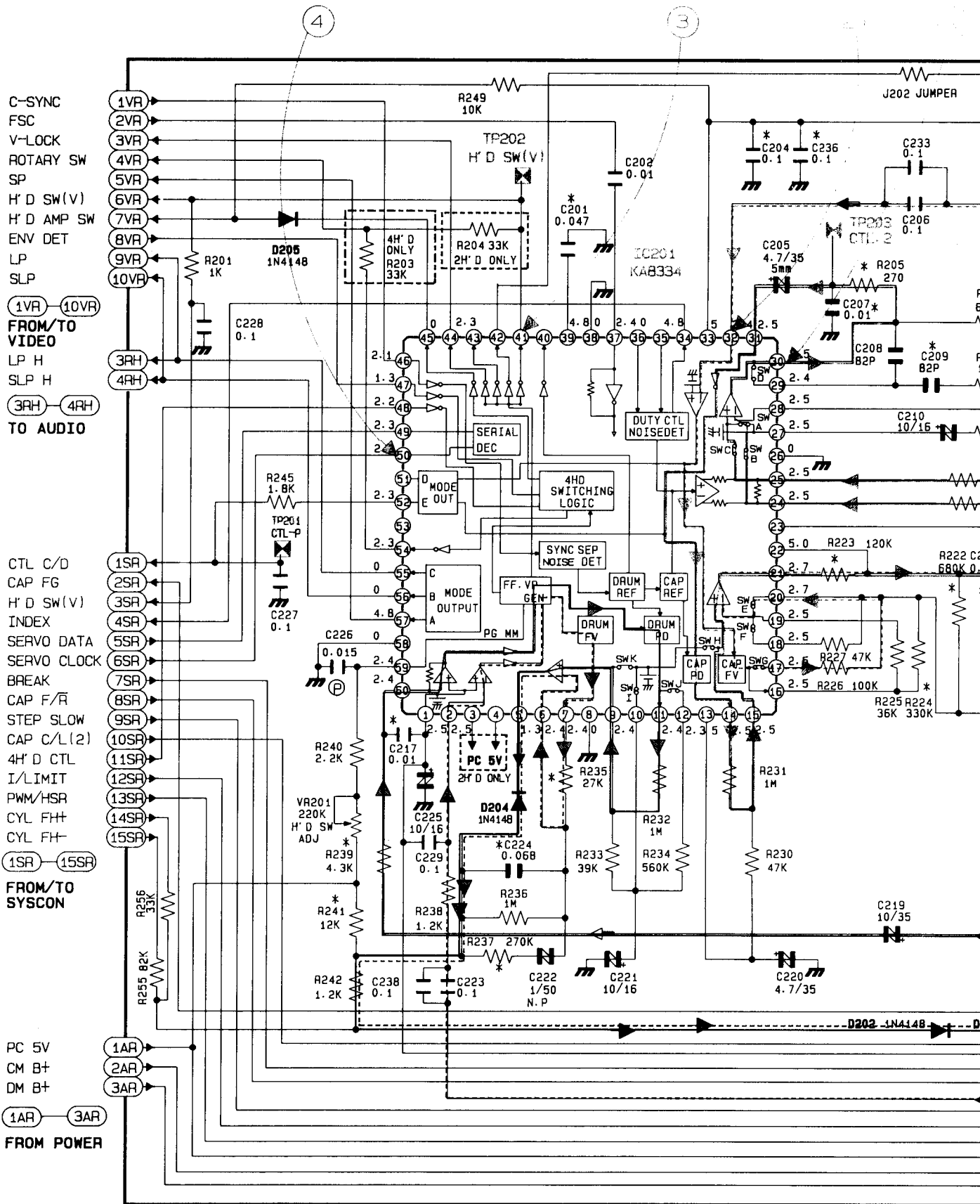

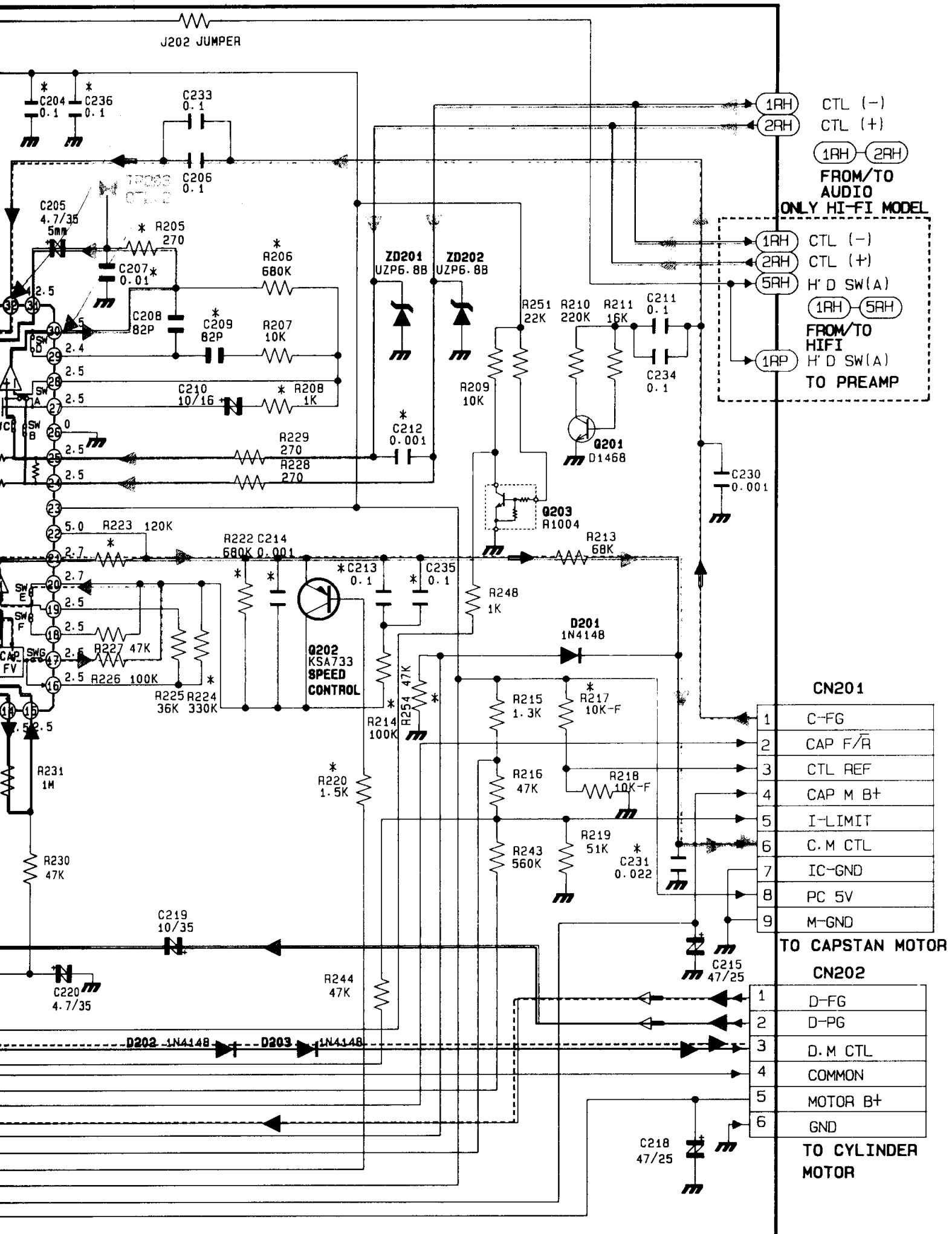

1RH CTL (-)
 2RH CTL (+)
 1RH 2RH FROM/TO AUDIO ONLY HI-FI MODEL
 1RH 5RH H'D SW(A)
 1RH 5RH FROM/TO HIFI H'D SW(A)
 1RP TO PREAMP

CN201

1	C-FG
2	CAP F/R
3	CTL REF
4	CAP M B+
5	I-LIMIT
6	C.M CTL
7	IC-GND
8	PC 5V
9	M-GND

TO CAPSTAN MOTOR CN202

1	D-FG
2	D-PG
3	D.M CTL
4	COMMON
5	MOTOR B+
6	GND

TO CYLINDER MOTOR

①

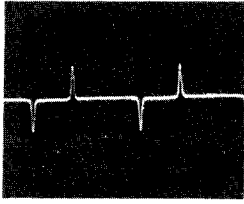

IC201-30
1.5Vp-p
PB

②

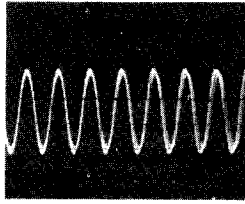

IC201-32
1.7Vp-p
PB

③

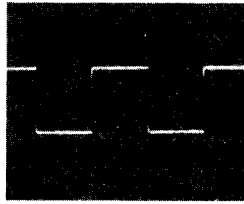

IC201-41
5.0Vp-p
PB/REC

④

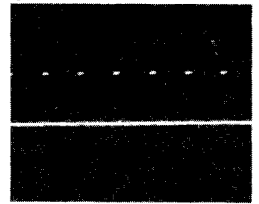

IC201-50
5.0Vp-p
PB/REC

MODE LOCA.NO	STOP	REC	PLAY
IC201			
1	2.5	2.5	2.5
2	1.9	2.5	2.5
3	0	2.5	2.5
4	0	2.5	2.5
5	0	1.7	0
6	0	2.8	2.5
7	2.5	2.5	2.3
8	0	0	0
9	2.4	2.9	2.6
10	2.5	3.3	2.5
11	5.0	2.8	4.5
12	2.3	3.4	3.0
13	2.5	2.9	2.6
14	3.3	0	1.8
15	2.6	2.6	2.6
16	0	0	3.6
17	0	0	3.6
18	0.3	0	2.6
19	0.1	2.5	2.5
20	0.1	2.5	2.5
21	0	2.6	3.1
22	0	2.7	2.7
23	5.1	5.1	5.1
24	2.5	2.0	2.5
25	2.5	2.9	2.5
26	0	0	0
27	2.5	2.5	2.5
28	2.5	2.5	2.5
29	0.7	2.1	3.8
30	2.5	2.5	2.5
31	1.1	2.3	4.4
32	-0.5	2.5	4.6
33	5.1	5.1	5.1
34	3.4	3.4	3.4
35	5.0	5.0	5.0
36	0	0	0
37	-0.3	1.9	4.5
38	0	0	0
39	-0.5	-0.5	5.2
40	2.6	2.6	2.6
41	0	2.5	2.5
42	0	0	2.5
43	0	2.5	2.5
44	0	0	0
45	0	5.1	5.1
46	0.6	0.7	1.3
47	5.2	0.3	0.7
48	0	0	0
49	0.5	0.5	0.5

MODE LOCA.NO	STOP	REC	PLAY
50	0.7	0.7	0.7
51	0	2.5	2.5
52	0	3.0	1.9
53	0	0	0
54	2.5	2.5	2.5
55	0	0	0
56	0	5.0	5.0
57	5.1	0	0
58	0	0	0
59	0	0	0
60	2.5	2.5	2.5
Q201			
E	0	0	0
B	0.5	0.2	0.2
C	5.0	5.0	5.0
Q202			
E	2.7	2.7	2.7
B	2.6	2.6	2.6
C	5.0	5.0	5.0
Q203			
E	0	0	0
B	1.3	2.6	2.6
C	0	2.1	2.0

IC201 KA8334

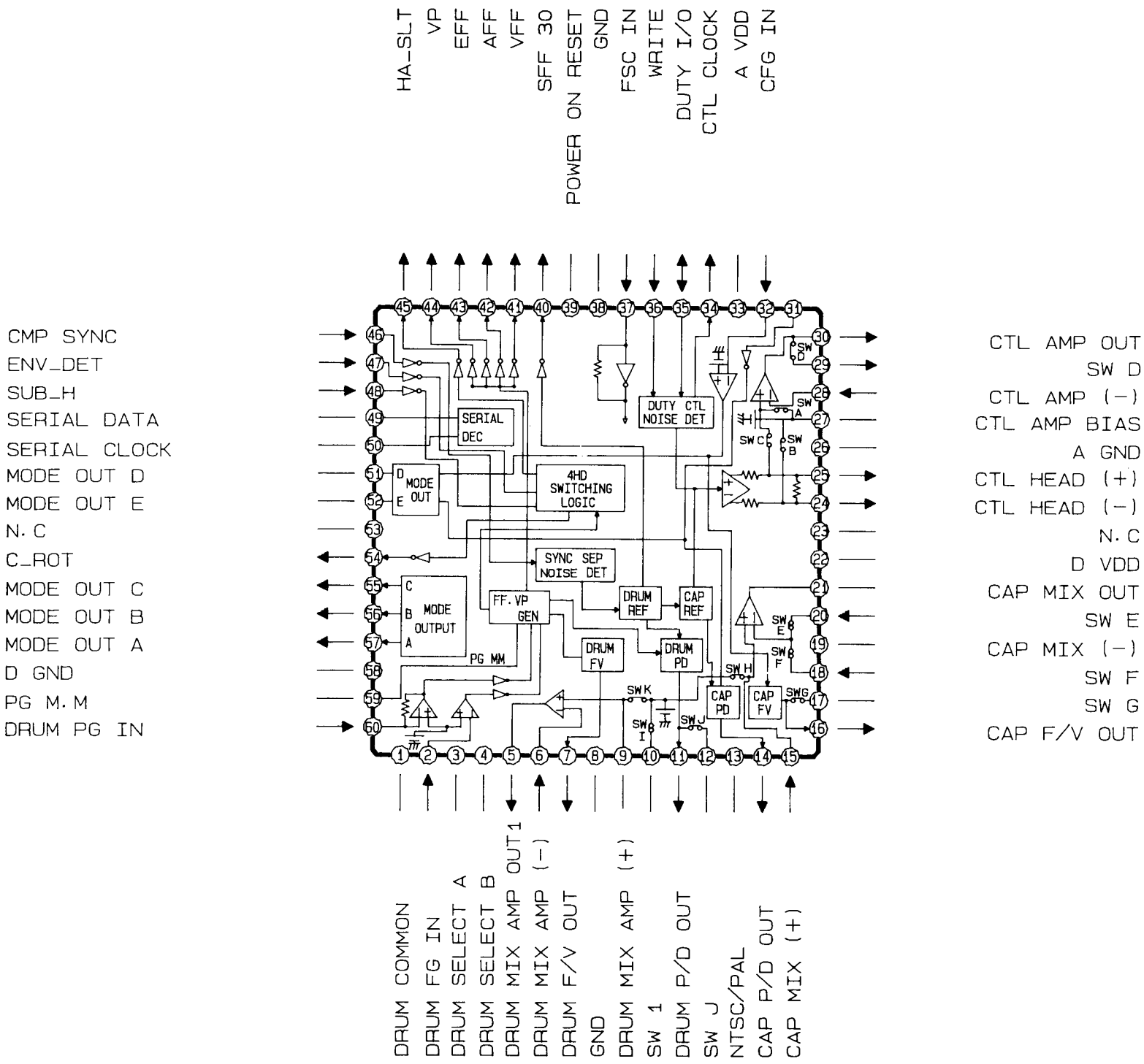

10-14. SYSTEM CONTROL

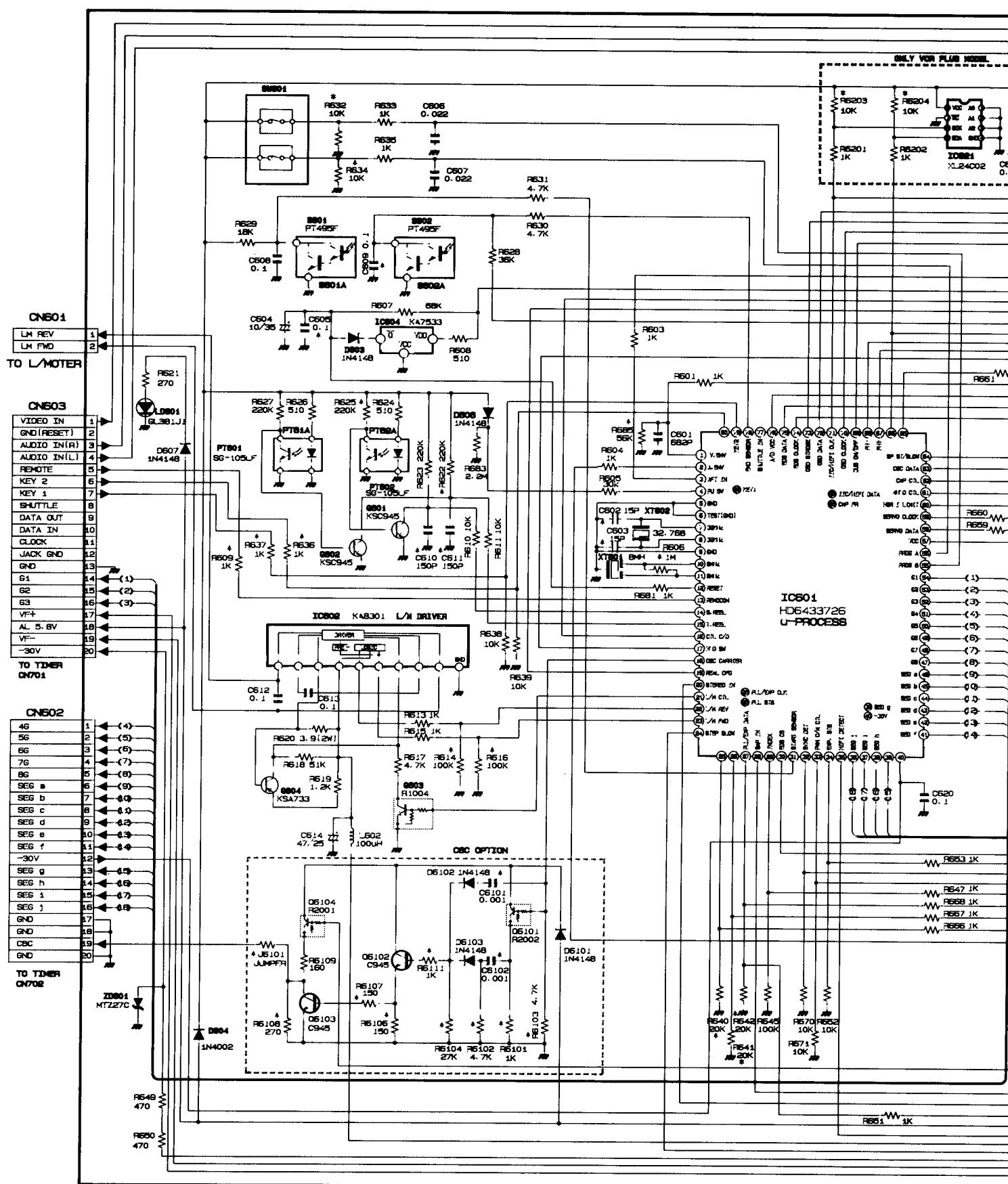

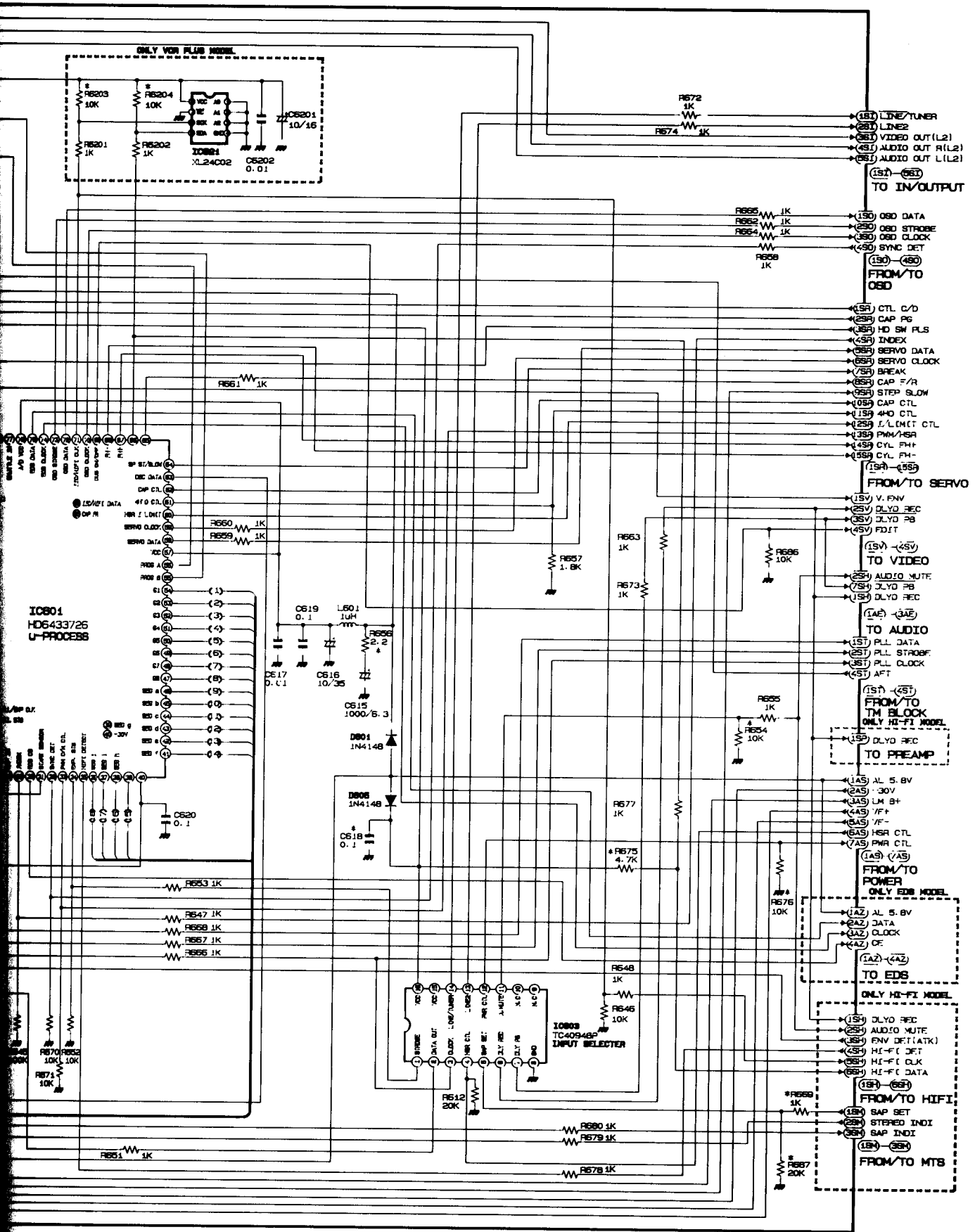

ONLY FOR PLUS MODEL

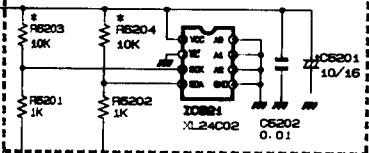

- (181) LINE TUNER
- (201) LINE2
- (202) VIDEO OUT (L2)
- (431) AUDIO OUT R(L2)
- (432) AUDIO OUT L(L2)

(157) - (163) TO IN/OUTPUT

- R665 1K
- R664 1K
- R664 1K
- R668 1K
- (130) OSD DATA
- (290) OSD STROBE
- (360) OSD CLOCK
- (450) SYNC DET

(130) - (450) FROM/TO OSD

- (451) CTL C/D
- (291) CAP PG
- (361) HD SW PLS
- (452) INDEX
- (661) SERVO DATA
- (662) SERVO CLOCK
- (751) BREAK
- (851) CAP F/R
- (951) STEP SLOW
- (1051) CAP CTL
- (1151) 4HD CTL
- (1251) Z/LIMIT CTL
- (1351) PWM/MSR
- (1451) CYL PH
- (1551) CYL PH

(131) - (155) FROM/TO SERVO

- (151) V. FNV
- (251) DLYD REC
- (351) DLYD PB
- (451) FDIIT

(151) - (451) TO VIDEO

- (251) AUDIO MUTE
- (751) DLYD PB
- (151) DLYD REC

(1A1) - (3A1) TO AUDIO

- (151) PLL DATA
- (251) PLL STROBE
- (351) PLL CLOCK
- (451) APT

(151) - (451) FROM/TO TIM CLOCK

ONLY HI-FI MODEL

- (151) DLYD REC

TO PREAMP

- (1A5) AL 5. BV
- (2A5) AL 30
- (3A5) LM 5H
- (4A5) /F+
- (5A5) /F-
- (6A5) HSR CTL
- (7A5) PWR CTL

(1A5) - (7A5) FROM/TO POWER

ONLY EDS MODEL

- (1A2) AL 5. BV
- (2A2) DATA
- (3A2) CLOCK
- (4A2) OF

(1A2) - (4A2) TO EDS

ONLY HI-FI MODEL

- (151) DLYD REC
- (251) AUDIO MUTE
- (351) ENV DET (ATK)
- (451) HI-FI DET
- (551) HI-FI CLK
- (651) HI-FI DATA

(151) - (651) FROM/TO HI-FI

- (151) SAP SET
- (251) STEREO INDI
- (351) SAP INDI

(151) - (351) FROM/TO MTS

IC801
HD64337/26
U-PROCESSOR

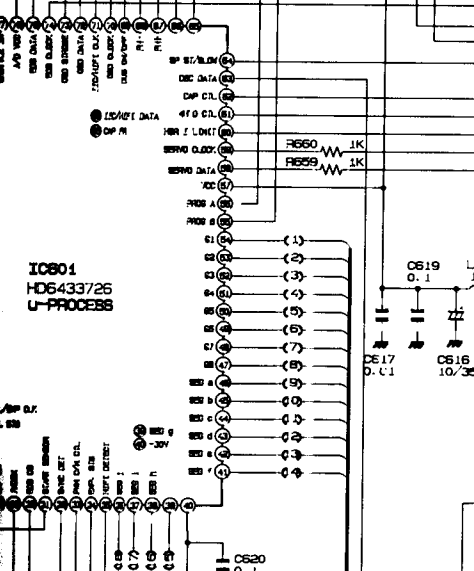
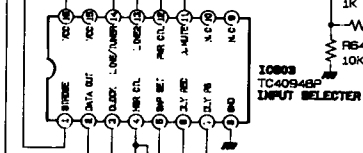

MODE LOCA.NO	STOP	REC	PLAY
IC601			
1	0.2	0	1.6
2	2.1	2.6	2.0
3	3.6	4.7	5.5
4	5.1	5.1	5.1
5	0	0	0
6	0	0	0
7	1.6	2.6	1.4
8	2.1	3.9	2.1
9	0	0	0
10	-	-	-
11	-	-	-
12	5.0	2.5	-0.4
13	5.7	5.4	4.8
14	4.0	4.8	-0.4
15	2.5	4.8	-0.4
16	0.4	3.0	1.6
17	0.5	2.5	2.5
18	0.5	5.0	5.0
19	0.5	2.1	1.3
20	0.4	0	-0.7
21	-4.6	5.0	5.0
22	-0.5	5.0	5.0
23	-0.5	5.0	5.0
24	-10.6	-3.4	-18.4
25	0	0.4	0.4
26	0	0	0
27	0	0	0
28	0.9	5.0	5.0
29	0	3.0	3.0
30	4.7	4.5	0
31	4.7	4.8	4.7
32	0	0	4.4
33	0	4.9	4.9
34	0	4.5	4.5
35	1.0	4.9	4.9
36	-22.5	-16.4	-18.7
37	-22.5	-26.1	-23
38	-22.5	-22	-22.6
39	-22.5	-26.1	-22.6
40	-27.5	-26	-26
41	-22.8	-26	-22.5
42	-22.3	-15	-5.7
43	-22.2	-3.3	0.8
44	-22.1	-3.1	-2.7
45	-21.8	-7.1	-5.2
46	-21.9	-15.5	-5.6
47	-21.5	-10	-1.5
48	-21.9	-8.0	-9.7
49	-25.9	-19.6	-19.2

MODE LOCA.NO	STOP	REC	PLAY
50	-25.1	-18.6	-18.2
51	-24.7	-17.9	-17.9
52	-24.4	-17.9	-18.1
53	-23.6	-16.9	-17.3
54	-23.0	-16.5	-17.3
55	0	4.9	5.0
56	0	0	0
57	6.5	5.0	5.0
58	0	0	0
59	0	0.3	0.3
60	0	1.8	0.2
61	0	0	0
62	0	5.0	5.0
63	0	5.0	5.0
64	0.6	1.5	-0.3
65	0.2	4.6	4.6
66	4.5	0	0
67	-0.5	0	0
68	-5.0	4.9	0
69	-0.5	5.0	0
70	0	4.9	4.9
71	4.0	0	0
72	0	0	0
73	-0.5	0	0
74	5.1	5.0	5.0
75	-0.5	3.5	3.5
76	5.4	5.0	5.0
77	-0.5	1.9	2.2
78	2.4	4.9	5.3
79	0	0	0
80	0	3.1	3.1
IC602			
1	0	0	0
2	0.5	0.5	0.5
3	0.9	0.9	0.9
4	1.0	1.0	1.0
5	3.2	3.2	3.2
6	3.2	3.2	3.2
7	12.8	12.8	12.8
8	12.8	12.8	12.8
9	0.9	0.9	0.9
10	0.5	0.5	0.5
IC603			
1	0.3	0.5	0.5
2	5.2	5.2	5.2
3	5.1	5.1	5.1
4	0.6	0.6	1.5
5	0.5	0.5	1.9
6	0.5	0.5	4.0
7	0.2	0.5	4.0

MODE LOCA.NO	STOP	REC	PLAY
8	0	0	0
9	0	0	0
10	0	0	0
11	3.5	1.3	2.3
12	5.2	0	5.2
13	2.6	0.9	3.0
14	2.7	1.2	2.0
15	2.7	0.9	0.4
16	5.2	5.4	5.4
IC604			
1	5.0	5.0	5.0
2	0	0	0
3	4.8	4.8	5.8
Q601			
E	0	0	0
B	0	0	0
C	0.5	0.3	0
Q602			
E	0	0	0
B	0	1.1	0
C	0.5	0.2	0
Q603			
E	5.0	5.0	5.0
B	0	0	0
C	0	0	0
Q604			
E	12.7	12.7	12.7
B	12.7	12.7	12.7
C	1.0	1.0	1.0

IC601 HD6433726

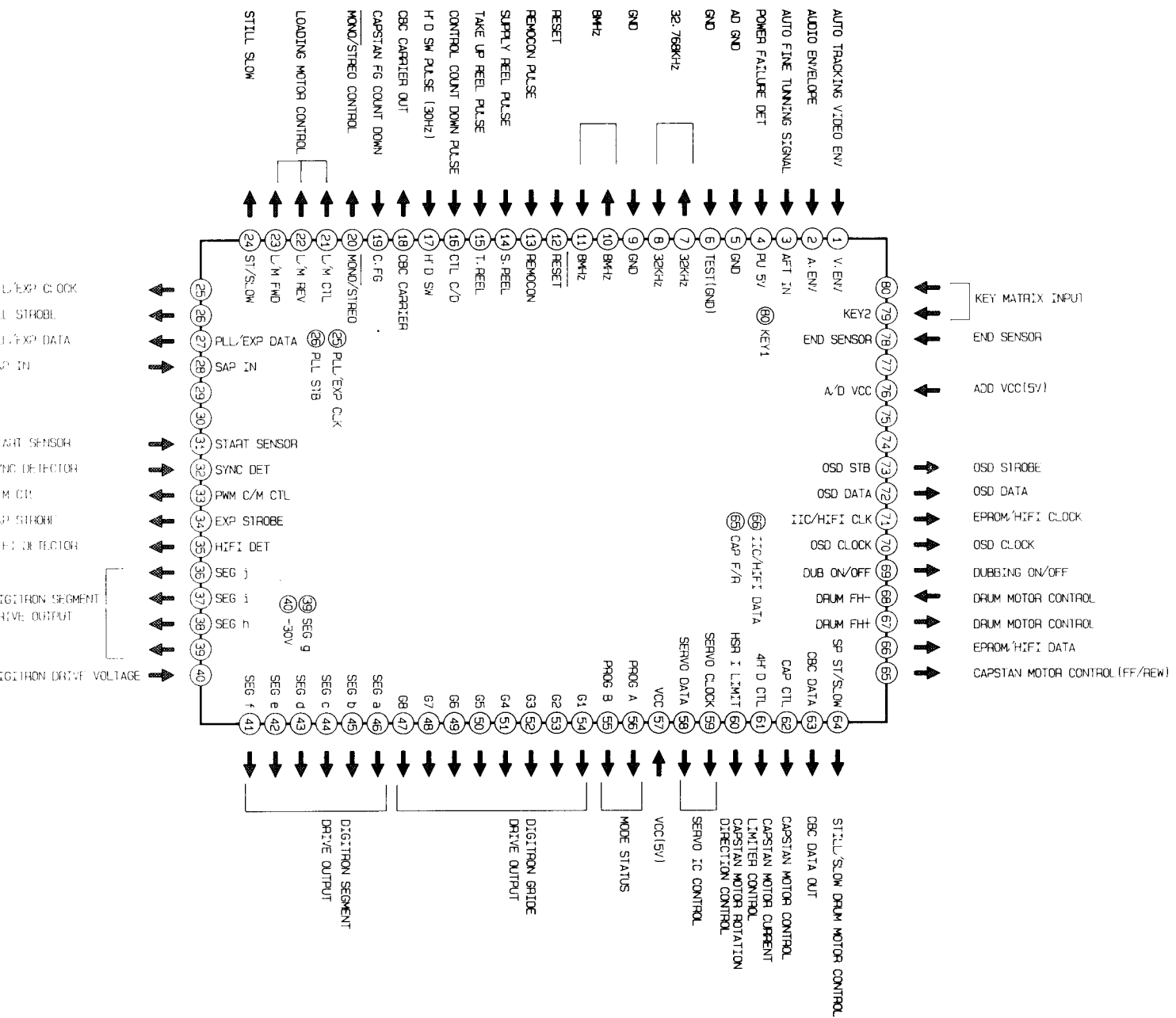

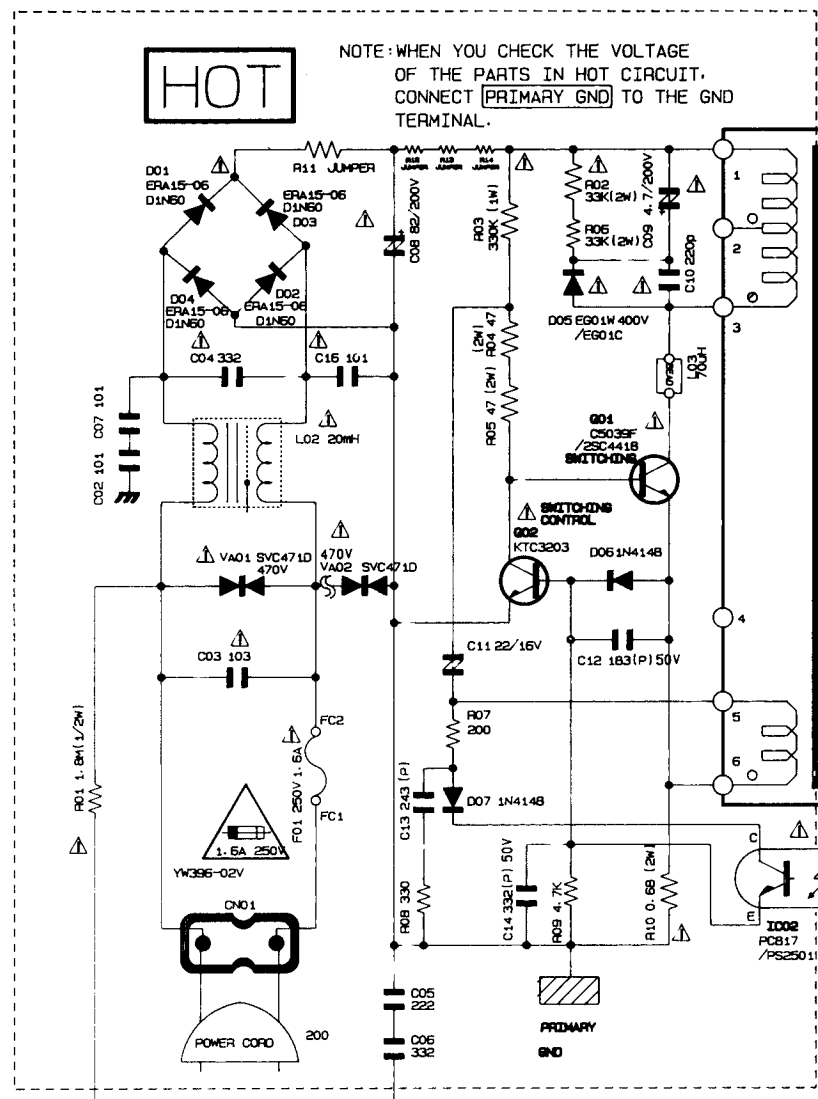

IMPORTANT SAFETY NOTICE
 COMPONENTS IDENTIFIED WITH THE MARK HAVE THE SPECIAL CHARACTERISTICS FOR SAFETY. WHEN REPLACING ANY OF THESE COMPONENTS, USE ONLY THE SAME TYPE.

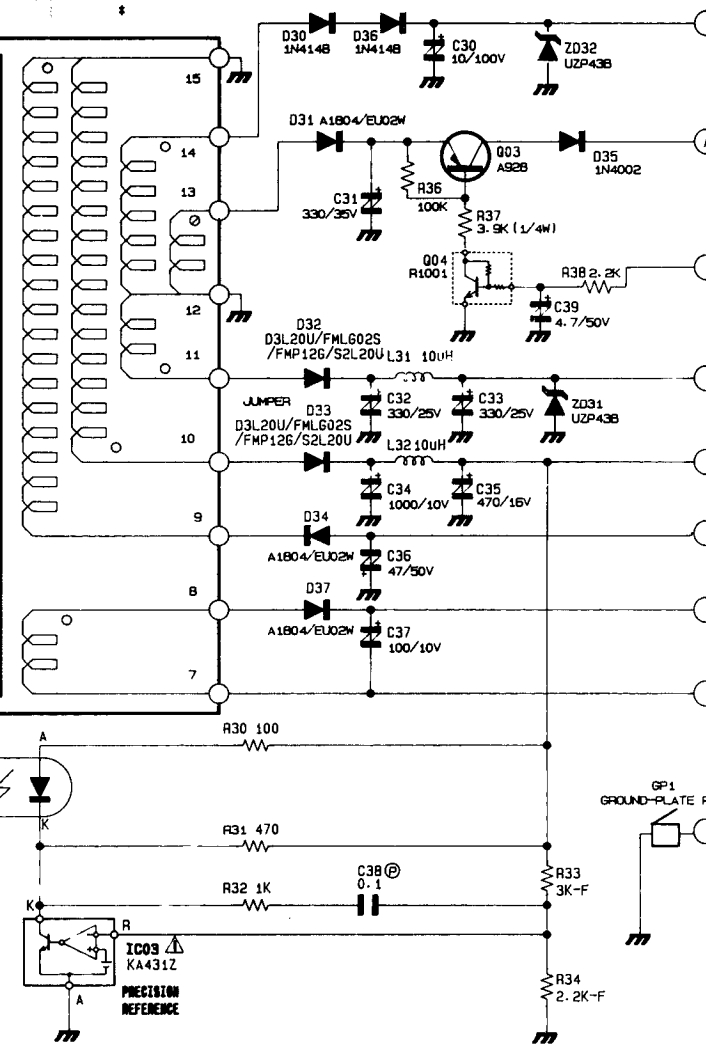

SMPS BLOCK

SAFETY NOTICE
 IDENTIFIED WITH THE MARK 
 SPECIAL CHARACTERISTICS FOR
 REPLACING ANY OF THESE
 USE ONLY THE SAME TYPE.

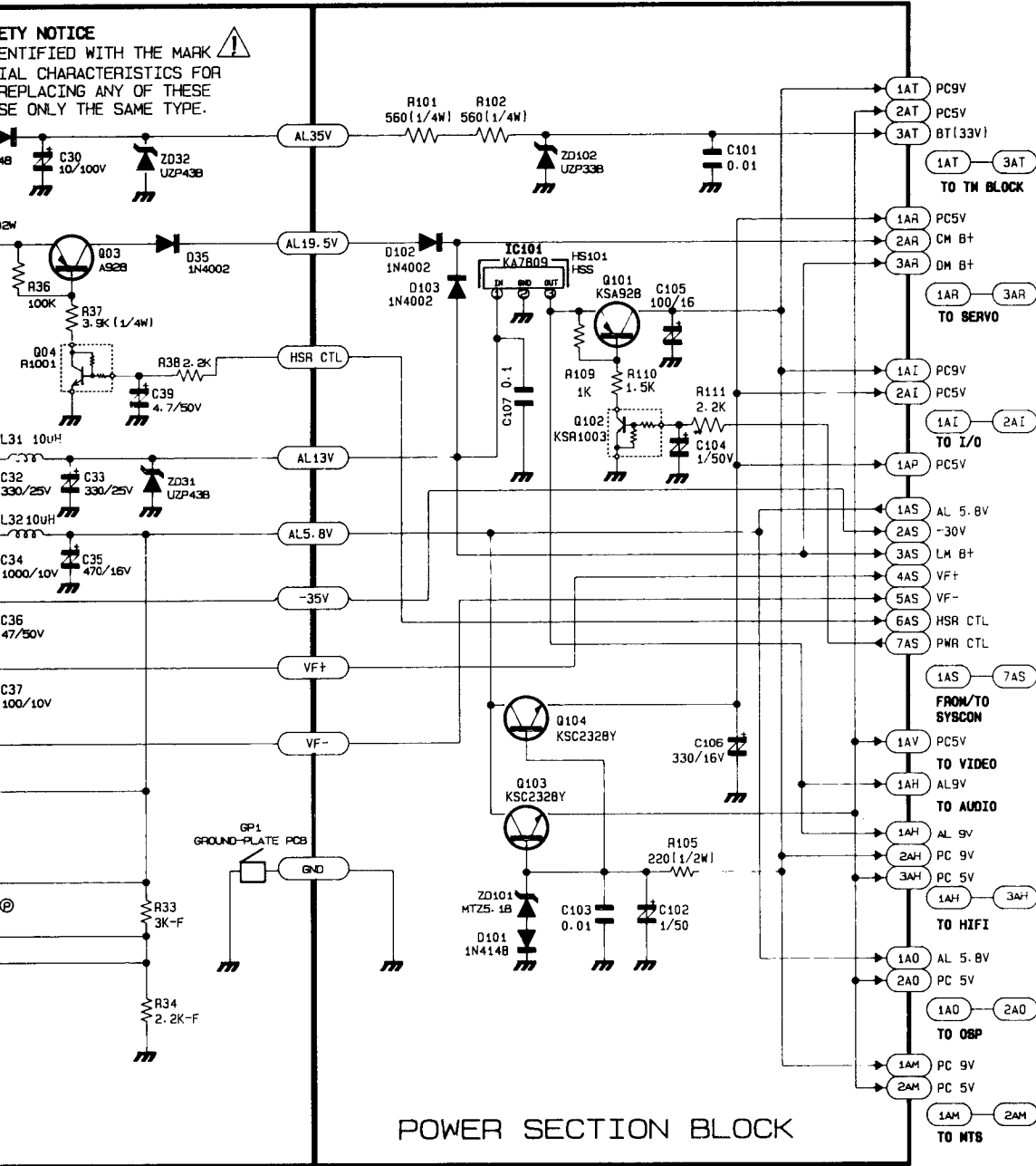

POWER SECTION BLOCK

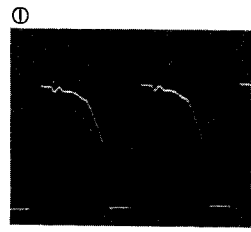

Q01-C
 240Vp-p
 POWER OFF



Q01-C
 270Vp-p
 POWER ON

MODE	STOP	REC	PLAY
IC02			
A	5.7	5.7	5.7
C	-48	-48	-49.5
E	-48	-47.8	-50
K	4.6	4.6	4.6
Q01			
E	-52	-52	-52
B	-52	-52	-52
C	56	56	56
Q02			
E	-51	-51	-51
B	-51	-51	-51
C	-51	-51	-51
Q03			
E	20	20	20
B	20	20	20
C	-0.5	-0.5	-0.5
Q04			
E	0	0	0
B	0	0	0
C	20	20	20
Q101			
E	8.9	8.9	8.9
B	8.9	8.9	8.9
C	8.2	8.2	8.2
Q102			
E	0	0	0
B	0	0	0
C	4.5	4.5	4.5
Q103			
E	5.1	5.1	5.1
B	5.8	5.8	5.8
C	5.7	5.7	5.7
Q104			
E	5.1	5.1	5.1
B	5.7	5.7	5.7
C	5.8	5.8	5.8

6. REPLACEMENT PARTS LIST

6-1. REPLACEMENT PARTS LIST FOR M-472,M-462,M-45

NOTE :

- The PC board assembly with * mark is no longer available after the end of the production.
- This parts listed on the base model M-472. For M-462,M-45 different parts only are listed on the difference list.

L/C NO.	PARTS NO.	REPLACEMENT NO.	DESCRIPTION;SPECIFICATION
---------	-----------	-----------------	---------------------------

- MECHANICAL PARTS -

922	70790704	67008-130-171	SCREW PH;+M3X3 FE FZY
951	70790086	67334-600-310	WASHER SLIT;PI2.5XPI5XT0.5
952	70790085	67304-103-410	WASHER-PLAIN;3.2X6X0.5 POLYSLIDER
956	70790154	67334-601-830	SLIT WASHER;2.5X9X0.5(RED)
958	70790154	67334-601-830	SLIT WASHER;2.5X9X0.5(RED)
A101	70790852	69000-501-317	ASSY PANEL FRONT;M-472
A101C	70790601	62724-0090-00	MASK SPRING;SUS 304(GE/RCA)
A102A	70790848	64042-0222-05	DOOR-CASSETTE;ABS94HB BLK M472
A104A	70790795	62002-0037-01	CABINET-TOP;TEXTURE T0.625 M-462
A104C	70790082	67158-240-163	SCREW-TAP BH;2-4X16 FE FZB
A120	70790635	63312-0163-00	COVER-BOTTOM;SECC T0.5 WHT SV-50
A120A	70790081	67158-230-120	SCREW-TAP TITE BH;3X10 FE FZY
A701	70790851	65003-0044-42	PACKING CASE;M-472 SW3 A YEL
A702	70790682	65231-0133-00	CUSHION-F/B;EPS#58 M-461 T15 W442 L390
A704	70790169	68654-604-720	NITRON BAG-SET;570X550X0.5T PAL
B210	70790218	67158-240-121	SCREW-TAP TITE;BH +TB 3 L12 SWRCH18A ZPC3
B251	70790560	61641-0023-00	SLIDER-MAIN;POM T12.4 NAT
B252	70790517	61473-0107-00	GEAR-LOADING L ASSY;X-5
B253	70790515	61473-0105-00	GEAR-LOADING R ASSY;X-5
B254	70790609	62724-0211-00	SPRING-BRAKE CAPSTAN;ES SUS304WPB P10.4
B255	70790735	61472-0104-01	GEAR-MASTER;POM(M90-44) Z60 SP NAT
B256	70790691	66823-0059-00	MOTOR-D.D CAPSTAN;F2QTB04
B257	70790524	61494-0009-00	BELT-CAPSTAN;CY-65 FR W2 T2 L88.6
B258	70790510	61453-0003-00	CLUTCH-ASSY;
B259	70790534	61533-0095-00	LEVER-SLIDER PINCH;PBT T4 NAT
B260	70790514	61473-0102-00	GEAR-WORMWHEEL;POM M0.55 Z57 SP NAT
B261	70790531	61533-0090-00	LEVER-SHIFT;PBT T2.5
B262	70790532	61533-0091-00	LEVER-IDLER CHANGE;PBT T3.3
B263	70790607	62724-0207-00	SPRING-LEVER SHIFT;TS SUS304WPB P10.7 ID
B264	70790713	67172-0173-00	UNIT-LOADING(ASSY);X-5
B265	70790692	66823-0060-00	MOTOR-LOADING ASSY;POM+RF370C X-5
B266	70790523	61474-0103-00	GEAR-WORM LOADING;PBT M0.55 WO NAT
B267	70790649	63324-0299-00	HOLDER-SHAFT;POM NAT
B268	70790597	62614-0014-00	BRAKE-CAPSTAN ASSY;POM X-5
CB81A	70790078	67098-130-065	SCREW TAP TITE BH;3X10 FE FZB
DT01A	70790755	63323-0427-00	HOLDER-TIMER;ABS 94HB BLK M-456
H500	70790797	62052-0014-01	HOUSING-ASSY;X5FL2630B(TSB)

NOTE :

- The PC board assembly with * mark is no longer available after the end of the production.
- This parts listed on the base model M-472. For M-462,M-45 different parts only are listed on the difference list.

L/C NO.	PARTS NO.	REPLACEMENT NO.	DESCRIPTION;SPECIFICATION
H510	70790581	62202-0103-00	CHASSIS-UPPER;SECC T1.0 NAT X-5
H520	70790645	63322-0317-00	HOLDER-CASSETTE(ASSY);SECC X5FL0810A X-5
H521	70790641	63321-0314-00	HOLDER-CASSETTE;SECC NAT 1/8H HRB 50
H522	70790540	61533-0102-00	LEVER-LOCK(R);SECC T1.2
H523	70790542	61533-0104-00	LEVER-LOCK(L);SECC T1.2
H524	70790618	62724-0220-00	SPRING-LEVER LOCK;ES SUS304WPB P10.2 ID2
H525	70790618	62724-0220-00	SPRING-LEVER LOCK;ES SUS304WPB P10.2 ID2
H526	70790541	61533-0103-00	LEVER-KEY CASSETTE;POM(LUCEL N109-LD) NA
H531	70790579	62201-0102-00	CHASSIS-SIDE "L";ABS(HF-380) T10 BLK X-5
H532	70790530	61532-0101-00	LEVER-LIGHT SHUTTER;POM(LUCEL N109-LD) B
H533	70790617	62724-0219-00	SPRING-LIGHT SHUTTER;ES SUS304WPB P10.2
H535	70790539	61533-0100-00	LEVER-DOOR;POM(LUCEL N109P-LD) BLK T5
H540	70790583	62203-0104-00	CHASSIS-SIDE "R"(ASSY);ABS X5FL0505A X-5
H541	70790578	62201-0101-00	CHASSIS-SIDE "R";ABS(HF-380) T10 BLK X-5
H542	70790565	61642-0032-00	SLIDER-DAMPER;POM(LUCEL N109-LD) T4 BLK
H543	70790616	62724-0218-00	SPRING-SLIDE DAMPER;ES SUS304WPB P10.4 1
H544	70790538	61533-0099-00	LEVER-LID OPENER;POM(LUCEL N109-LD) NAT
H545	70790620	62724-0222-00	SPRING-LID OPENER;TS SWPB P10.55 ID8.9 0
H550	70790504	61403-0073-00	SHAFT-ARM(ASSY);SUM24L X5FL0405A X-5
HSS	70790179	67158-230-081	SCREW-TAP BH;2-3X8 FE FZY
JK01A	70790420	63014-0153-00	BRACKET-JACK;SPT E T0.5
LD61A	70790648	63323-0313-00	HOLDER-LED;POM
LD71A	70790786	63324-0411-00	HOLDER-C.B.C;ABS94HB BLK M-461
PT61A	70790647	63323-0312-00	HOLDER-PHOTO;POM
PT62A	70790647	63323-0312-00	HOLDER-PHOTO;POM
S601A	70790642	63322-0311-00	HOLDER-TR;POM
S602A	70790642	63322-0311-00	HOLDER-TR;POM
T201	70790557	61574-0023-00	REEL-DISK L ASSY;POM D30 X-5
T202	70790556	61574-0021-00	REEL-DISK R ASSY;POM D X-5
T203	70790592	62613-0013-00	BRAKE-SUB L;PBT X-5
T204	70790596	62614-0011-00	BRAKE-SUB R ASSY;PBT LUPOX EG 5000H X-5
T207	70790595	62614-0009-00	BRAKE-MAIN L ASSY;PBT X-5
T208	70790594	62614-0007-00	BRAKE-MAIN R ASSY;PBT X-5
T209	70790608	62724-0208-00	SPRING-BRAKE MAIN;ES SUS304WPB PT0.35 ID
T210	70790522	61474-0099-00	GEAR-RELAY S ASSY;PEBAX M0.5 M48 SP
T211	70790520	61474-0095-00	GEAR-RELAY(T);PEBAX#6333 M0.5 Z41 SP X-5
T212	70790549	61543-0071-00	ARM-TENSION FULL ASSY;X-5
T216	70790613	62724-0215-00	SPRING-TENSION;ES SUS304WPB P10.35 ID2.1
T217	70790537	61533-0098-00	LEVER-REC S/W;PBT
T218	70790615	62724-0217-00	SPRING-REC S/W;ES SUS304 P10.23 D3.5 L14
T219	70790686	66603-0005-00	MAGNET-F/E HEAD;X-5
T220	70790567	61643-0027-00	SLIDER-G/R ASSY(S);X-5
T221	70790569	61643-0029-00	SLIDER-G/R ASSY(T);X-5

NOTE :

- The PC board assembly with * mark is no longer available after the end of the production.
- This parts listed on the base model M-472. For M-462,M-45 different parts only are listed on the difference list.

L/C NO.	PARTS NO.	REPLACEMENT NO.	DESCRIPTION; SPECIFICATION
T223	70790561	61642-0022-00	SLIDER-RACK HOUSING;POM T10.5 BLK
T224	70790687	66603-0006-00	MAGNET-ACE HEAD ALL(ASSY);X-5
T225	70790562	61642-0024-00	SLIDER-PINCH;POM T2 NAT
T226	70790535	61533-0096-00	LEVER-REVIEW;ZYTEL T3.8 BLK
T227	70790551	61544-0073-00	ARM-REVIEW ASSY;PPS X-5
T228	70790533	61533-0094-00	LEVER-PINCH CAM;PC T5 X-5
T229	70790529	61532-0093-00	LEVER-PINCH COMP;PBT T13.3 X-5
T230	70790610	62724-0212-00	SPRING-PINCH(COMP);TS SWPB P11.0 ID6 OD8
T231	70796161	62713-0054-00	PRISM-LED;PMMA D5 IF-850
T232	70790566	61643-0025-00	SLIDER-PUSH;LUPOX 2150 T2 NTR
T233	70790614	62724-0216-00	SPRING-SLIDE PUSH;ES SUS304WPB P10.55 D3
T234	70790714	67172-0174-00	UNIT-PINCH ROLLER(ASSY);X-5
T236	70790559	61603-0006-00	IDLER-ASSY;POM X-5
T237	70790805	63383-0031-00	STOPPER-TAPE;POM T2 NAT X-5 DECK
T238	70790623	62724-0239-00	SPRING-ARM PINCH;CS SUS304 WPB P10.4 ID7
T300	70790746	69020-124-067	CYLINDER ASSY;CX5-D4N/TSB
T301	70790776	69000-400-204	CYLINDER SUB ASSY;CX5-D4N/TSB
T303	70790708	67084-0076-00	HEAD-BRUSH(ASSY);SECC20/20+CARBON
TM401	70790715	67179-0194-00	UNIT-TM BLOCK;TMVH2-A05A V1 NTSC
U602A	70790081	67158-230-120	SCREW-TAP TITE BH;3X10 FE FZY
Y104	70796352	AC68-10707A	INSTRUCTION;OWNER'S MANUAL M-472 ENG/SPA

- ELECTRICAL PARTS -

* U621	70796404	69657-301-277	ASSY MAIN;M-472
- INTEGRATED CIRCUITS -			
IC02	70796240	B4161-0027	PHOTO-COUPLER;PC817FN ST
IC03	70795271	A4008-0757	IC;S431C/LM431C SIP TAPG
IC101	70796016	A4008-0112	IC-REGULATION;KIA 7809P
IC201	70796383	A4008-1247	IC;KA8334B QFP 60PIN TRAY
IC301	70796236	B4012-0456	IC-LINEAR;LA7425 DIP BULK VIDEO-PROCESS
IC302	70796235	B4012-0452	IC-LINEAR;LA7416 DIP BULK
IC303	70796234	B4012-0299	IC-LINEAR;LC7975J DIP CCD
IC501	70796299	B4012-0273	IC-LINEAR;LA7286 DIP
IC601	70796388	AC09-10450D	IC-MCU;HD6433726SC65F M-672
IC602	70795131	62119-401-300	IC;KA8301(N.M)
IC603	70796390	B4008-0264	IC-LOGIC;HEF4094BP/TC4094BP DIP
IC604	70795269	A4008-0754	IC;KA7533
IC621	70796298	B4012-0110	IC-LINEAR;XL24C02 DIP
IC801	70795803	62119-401-310	IC;KA8403
IC802	70795803	62119-401-310	IC;KA8403
IC901	70796384	A4012-0653	IC-LINEAR;KS5514B-13 DIP BULK CMOS 24P

- TRANSISTORS -

NOTE :

- The PC board assembly with * mark is no longer available after the end of the production.
- This parts listed on the base model M-472. For M-462,M-45 different parts only are listed on the difference list.

L/C NO.	PARTS NO.	REPLACEMENT NO.	DESCRIPTION;SPECIFICATION
Q01	70795647	A4056-0027	TR-SWITCHING;KSC5039F 40W 10MHZ SI/NPN
Q02	70795142	62139-301-311	TRANSISTOR;KTC 3203Y-AT(TAPG)
Q03	70795143	62147-401-835	TRANSISTOR;KSA 928A-Y TAPG
Q04	70795137	62137-701-010	TRANSISTOR;KSR 1001 TAPG
Q101	70795143	62147-401-835	TRANSISTOR;KSA 928A-Y TAPG
Q102	70795817	62137-701-012	TRANSISTOR;KSR 1003 TAPG
Q103	70795135	62137-302-441	TRANSISTOR;KSC 2328-Y TAPG
Q104	70795135	62137-302-441	TRANSISTOR;KSC 2328-Y TAPG
Q201	70795496	A4050-0001	TRANSISTOR;2SD 1468SQ
Q202	70795134	62137-103-380	TRANSISTOR;KSA 733-Y TAPG
Q203	70795138	62137-701-013	TRANSISTOR;KSR 1004 TAPG
Q307	70795138	62137-701-013	TRANSISTOR;KSR 1004 TAPG
Q309	70795134	62137-103-380	TRANSISTOR;KSA 733-Y TAPG
Q310	70795136	62137-302-740	TRANSISTOR;KSC 945-Y TAPG
Q311	70795136	62137-302-740	TRANSISTOR;KSC 945-Y TAPG
Q312	70795136	62137-302-740	TRANSISTOR;KSC 945-Y TAPG
Q314	70795138	62137-701-013	TRANSISTOR;KSR 1004 TAPG
Q315	70796359	62137-701-023	TRANSISTOR ;KSR 2004 TAPG
Q316	70795136	62137-302-740	TRANSISTOR;KSC 945-Y TAPG
Q317	70795136	62137-302-740	TRANSISTOR;KSC 945-Y TAPG
Q318	70795136	62137-302-740	TRANSISTOR;KSC 945-Y TAPG
Q501	70795141	62137-702-020	TRANSISTOR;KSC 1008-Y TAPG
Q502	70795138	62137-701-013	TRANSISTOR;KSR 1004 TAPG
Q503	70795138	62137-701-013	TRANSISTOR;KSR 1004 TAPG
Q504	70795571	62137-701-020	TRANSISTOR;KSR 2001 TAPG
Q601	70795136	62137-302-740	TRANSISTOR;KSC 945-Y TAPG
Q602	70795136	62137-302-740	TRANSISTOR;KSC 945-Y TAPG
Q603	70795138	62137-701-013	TRANSISTOR;KSR 1004 TAPG
Q604	70795134	62137-103-380	TRANSISTOR;KSA 733-Y TAPG
Q6101	70795572	62137-701-021	TRANSISTOR;KSR 2002 TAPG
Q6102	70795136	62137-302-740	TRANSISTOR;KSC 945-Y TAPG
Q6103	70795136	62137-302-740	TRANSISTOR;KSC 945-Y TAPG
Q6104	70795571	62137-701-020	TRANSISTOR;KSR 2001 TAPG
Q801	70795134	62137-103-380	TRANSISTOR;KSA 733-Y TAPG
Q901	70795136	62137-302-740	TRANSISTOR;KSC 945-Y TAPG
		- DIODES -	
D01	70796301	B4104-0094	DIODE-RECT;ERA15-06 600V 1A T
D02	70796301	B4104-0094	DIODE-RECT;ERA15-06 600V 1A T
D03	70796301	B4104-0094	DIODE-RECT;ERA15-06 600V 1A T
D04	70796301	B4104-0094	DIODE-RECT;ERA15-06 600V 1A T
D05	70795587	B4102-0006	DIODE-FR;EG01C(3.3)V 500MA(0.1)VS
D06	70795150	62169-406-482	DIODE;1N4148 SAMSUNG
D07	70795150	62169-406-482	DIODE;1N4148 SAMSUNG

NOTE :

- The PC board assembly with * mark is no longer available after the end of the production.
- This parts listed on the base model M-472. For M-462,M-45 different parts only are listed on the difference list.

L/C NO.	PARTS NO.	REPLACEMENT NO.	DESCRIPTION;SPECIFICATION
D101	70795150	62169-406-482	DIODE;1N4148 SAMSUNG
D102	70796385	A4104-0053	DIODE-RECT;1N4002 100V 1A SI
D103	70796385	A4104-0053	DIODE-RECT;1N4002 100V 1A SI
D201	70795150	62169-406-482	DIODE;1N4148 SAMSUNG
D202	70795150	62169-406-482	DIODE;1N4148 SAMSUNG
D203	70795150	62169-406-482	DIODE;1N4148 SAMSUNG
D204	70795150	62169-406-482	DIODE;1N4148 SAMSUNG
D205	70795150	62169-406-482	DIODE;1N4148 SAMSUNG
D30	70795150	62169-406-482	DIODE;1N4148 SAMSUNG
D301	70795150	62169-406-482	DIODE;1N4148 SAMSUNG
D303	70795150	62169-406-482	DIODE;1N4148 SAMSUNG
D304	70795150	62169-406-482	DIODE;1N4148 SAMSUNG
D305	70795150	62169-406-482	DIODE;1N4148 SAMSUNG
D307	70795150	62169-406-482	DIODE;1N4148 SAMSUNG
D308	70795150	62169-406-482	DIODE;1N4148 SAMSUNG
D309	70795150	62169-406-482	DIODE;1N4148 SAMSUNG
D31	70795656	B4102-0047	DIODE-FR;ERA18-04 400V 0.8A 0.4US T
D311	70795150	62169-406-482	DIODE;1N4148 SAMSUNG
D32	70796300	B4102-0077	DIODE-SW;FML-G02S 200V 2.5A 40NS BULK
D33	70796300	B4102-0077	DIODE-SW;FML-G02S 200V 2.5A 40NS BULK
D34	70795656	B4102-0047	DIODE-FR;ERA18-04 400V 0.8A 0.4US T
D35	70796385	A4104-0053	DIODE-RECT;1N4002 100V 1A SI
D36	70795150	62169-406-482	DIODE;1N4148 SAMSUNG
D37	70795656	B4102-0047	DIODE-FR;ERA18-04 400V 0.8A 0.4US T
D501	70795150	62169-406-482	DIODE;1N4148 SAMSUNG
D601	70795150	62169-406-482	DIODE;1N4148 SAMSUNG
D603	70795150	62169-406-482	DIODE;1N4148 SAMSUNG
D604	70796385	A4104-0053	DIODE-RECT;1N4002 100V 1A SI
D605	70795150	62169-406-482	DIODE;1N4148 SAMSUNG
D606	70795150	62169-406-482	DIODE;1N4148 SAMSUNG
D607	70795150	62169-406-482	DIODE;1N4148 SAMSUNG
D6101	70795150	62169-406-482	DIODE;1N4148 SAMSUNG
D6102	70795150	62169-406-482	DIODE;1N4148 SAMSUNG
D6103	70795150	62169-406-482	DIODE;1N4148 SAMSUNG
D902	70795150	62169-406-482	DIODE;1N4148 SAMSUNG
D903	70795150	62169-406-482	DIODE;1N4148 SAMSUNG
D904	70795150	62169-406-482	DIODE;1N4148 SAMSUNG
LD601	70796302	B4150-0286	LED-INFRARED;GL381J1 YEL 950NM/3.5V
ZD101	70795147	62169-403-821	DIODE-ZENER;MTZ 5.1B
ZD102	70795272	A4106-0062	DIODE-ZENER;UZP33B 30/36 5MA T
ZD201	70795355	62169-423-092	DIODE-ZENER;MT 6.8B
ZD202	70795355	62169-423-092	DIODE-ZENER;MT 6.8B
ZD31	70795422	A4106-0068	DIODE-ZENER;UZP-18B 17/19V 20MA T

NOTE :

- The PC board assembly with * mark is no longer available after the end of the production.
- This parts listed on the base model M-472. For M-462,M-45 different parts only are listed on the difference list.

L/C NO.	PARTS NO.	REPLACEMENT NO.	DESCRIPTION;SPECIFICATION
ZD32	70795438	A4106-0076	DIODE-ZENER;UZP-43B 40/46V 10MA T
ZD601	70796360	62169-403-838	DIODE-ZENER;MTZ27C
		- CAPACITORS -	
C02	70795404	A1100-0536	C-CERAMIC;CKS 45 B 400V 101-K SC B 2G 101-K
C03	70795239	A1100-0423	C-CERAMIC;CK45B 400V B 103Z 16/SCE 2G 103Z 16B
C04	70795417	A1100-0580	C-CERAMIC;CK 45 B 400V T 3300-M SCF2G332M16BS
C05	70795252	A1100-0450	C-CERAMIC;CK45B 400V 222M 12/SC E 2G 222M 12BS
C06	70795417	A1100-0580	C-CERAMIC;CK 45 B 400V T 3300-M SCF2G332M16BS
C07	70795404	A1100-0536	C-CERAMIC;CKS 45 B 400V 101-K SC B 2G 101-K
C08	70795578	A1104-0379	C-ELEC;CE04F 200VT 820-M STX/KME-40/105
C09	70795580	A1104-0396	C-ELEC;CE04H 200VT 4R7-M KME/STX-25/105
C10	70795088	61417-110-224	C-CERAMIC HK;CK45B TAPG 500V 220-K
C101	70796389	B1102-0277	C-FILM;CQ 922 M 50V T 103-J ECQB1H103JF3
C102	70795114	61617-408-010	C-ELEC;CEAP 50V 1M RSS(4X7)
C103	70795075	61407-117-104	C-CERAMIC.AXIAL;CAX Y TAPG 16V 0.01-N
C104	70795114	61617-408-010	C-ELEC;CEAP 50V 1M RSS(4X7)
C105	70795627	61637-504-101	C-ELEC;CEAP 16V 100M SG(6.3X11)
C106	70796149	61637-504-331	C-ELEC;CEAP 16V 330M SG(10X12.5)
C107	70796207	A1100-0961	C-CERAMIC,CHIP;CK 73 Y5V 25V 104-Z C2010
C11	70795430	61627-204-220	C-ELEC;CEAP 16V 22M NP(6X11)
C12	70796231	B1102-0279	C-FILM;CQ 922 M 50V T 183-J ECQB1H183JF3
C13	70795586	61507-121-941	C-POLYESTER;CQ921M TAPG
C14	70795759	61507-121-411	C-POLYESTER;CQ921M TAPG 100V 332-J
C16	70795404	A1100-0536	C-CERAMIC;CKS 45 B 400V 101-K SC B 2G 101-K
C201	70796288	A1100-0745	C-CERAMIC,CHIP;CK 73 Y5V 50V T 473-Z C20
C202	70795075	61407-117-104	C-CERAMIC.AXIAL;CAX Y TAPG 16V 0.01-N
C204	70795072	61407-117-101	C-CERAMIC.AXIAL;UP050F 104Z
C205	70796211	A1104-0609	C-ELEC;CE 04 -40/85 35V T 4R7-M SRE 4X5
C206	70795072	61407-117-101	C-CERAMIC.AXIAL;UP050F 104Z
C207	70796205	A1100-0958	C-CERAMIC,CHIP;CK OB Y5V 16V 103-Z 20X12
C208	70796209	A1100-0970	C-CERAMIC,CHIP;CK OB Y5P 50V 820-K 20X12
C209	70796209	A1100-0970	C-CERAMIC,CHIP;CK OB Y5P 50V 820-K 20X12
C210	70796381	A1104-0611	C-ELEC;CE 04 -40/85 16V T 100-M SRE
C211	70795072	61407-117-101	C-CERAMIC.AXIAL;UP050F 104Z
C212	70795247	A1100-0444	C-CERAMIC,CHIP;UCN 053 Y 102M 1000P
C213	70796207	A1100-0961	C-CERAMIC,CHIP;CK 73 Y5V 25V 104-Z C2010
C214	70795247	A1100-0444	C-CERAMIC,CHIP;UCN 053 Y 102M 1000P
C215	70795621	61617-405-470	C-ELECTROLYTIC;CE04W TAPG 25V 47M(RSS 6.3X
C217	70795075	61407-117-104	C-CERAMIC.AXIAL;CAX Y TAPG 16V 0.01-N
C218	70795621	61617-405-470	C-ELECTROLYTIC;CE04W TAPG 25V 47M(RSS 6.3X
C219	70795113	61617-406-100	C-ELEC;CEAP 35V 10M RSS(5X7)
C220	70796211	A1104-0609	C-ELEC;CE 04 -40/85 35V T 4R7-M SRE 4X5
C221	70796381	A1104-0611	C-ELEC;CE 04 -40/85 16V T 100-M SRE