

Service
Service
Service

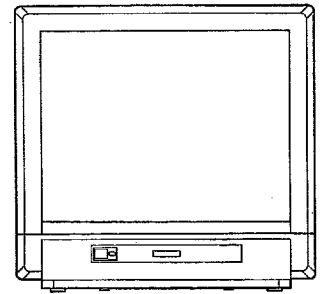

CL 26532053/022
290692

Service Manual

Safety regulations require that the set be restored to its original condition and that parts which are identical with those specified be used.

Les normes de sécurité exigent que l'appareil soit remis à l'état d'origine et que soient utilisées les pièces de rechange identiques à celles spécifiées.

CHASSIS ANUBIS A

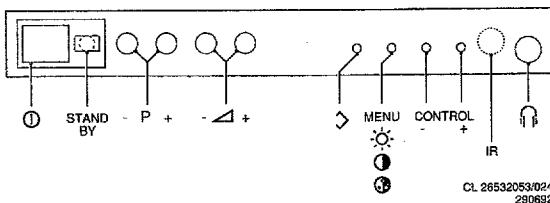

REAR CONNECTIONS

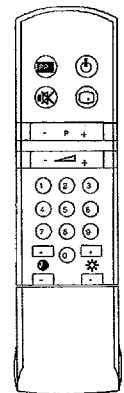
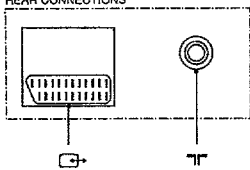

RC6802 C01A

RC6802



220-240 V (± 10%)
50 W



A41EAM11X13
4822 131 20407

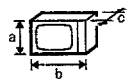

axbxc
421x392x403 mm



1x1W



-/00 : PAL BG
-/01 : PAL BGI
SECAM LL'



UV917E
Only for -/00
VHF_a : 46-118 MHz
VHF_b : 118-300 MHz
UHF : 470-861 MHz

UV915E
Only for -/01
VHF_a : 46-118 MHz
VHF_b : 118-300 MHz
Hyper : 300-470 MHz
UHF : 470-861 MHz



PHILIPS

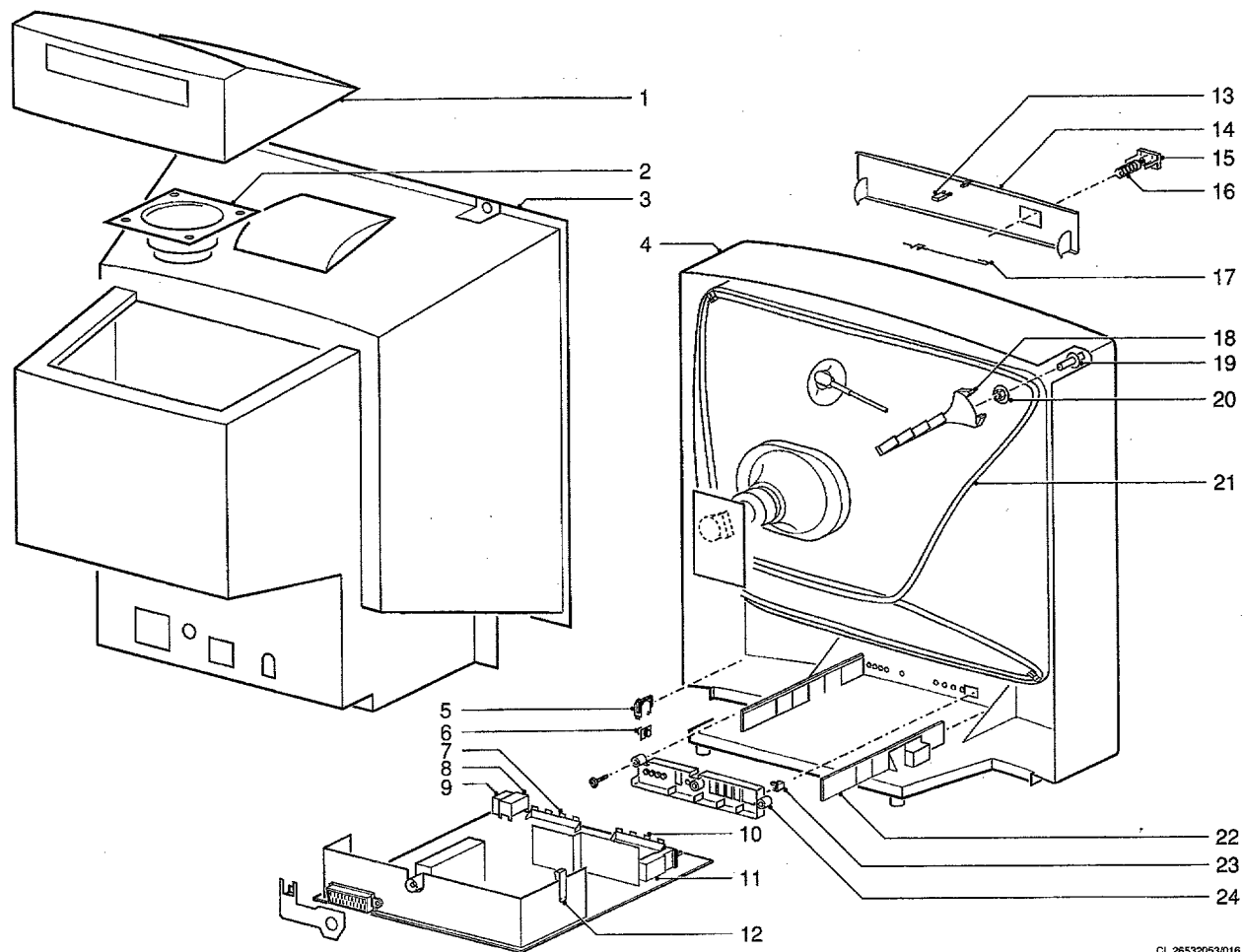

CL 28532053/016
240692

1	4822 445 10326	Loudspeaker box 15"/17"
2	4822 240 50328	Loudspeaker
3	4822 438 10391	Rear cover 17"
4	4822 430 10403	Cabinet 17"
5	4822 404 31237	Holder for damper
6	4822 522 31741	Damper
7	4822 276 40414	Switch assy right
8	4822 218 20981	RC5 Receiver
9	4822 267 31292	Headphone jack
10	4822 277 21438	Switch assy left
11	4822 276 12597	Mains switch
12	4822 492 70559	Spring for transistor
13	4822 278 10088	Lock mechanism
14	4822 492 32656	Door 17"
15	4822 410 62199	Mains button
16	4822 492 71148	Spring
17	4822 492 42628	Spring for door
18	4822 404 30753	Bracket
19	4822 503 21006	Spindle
20	4822 505 10924	Nut
21	4822 157 51636	Degaussing coil 15"/17"
22	4822 462 30557	Guide
23	4822 381 11362	LED lens
24	4822 410 62202	Button frame
	4822 218 21038	Remote control RC6802
	4822 303 40057	Aerial