

A DIGITAL STOPCLOCK FOR SHORT AND LONG EVENT TIMING

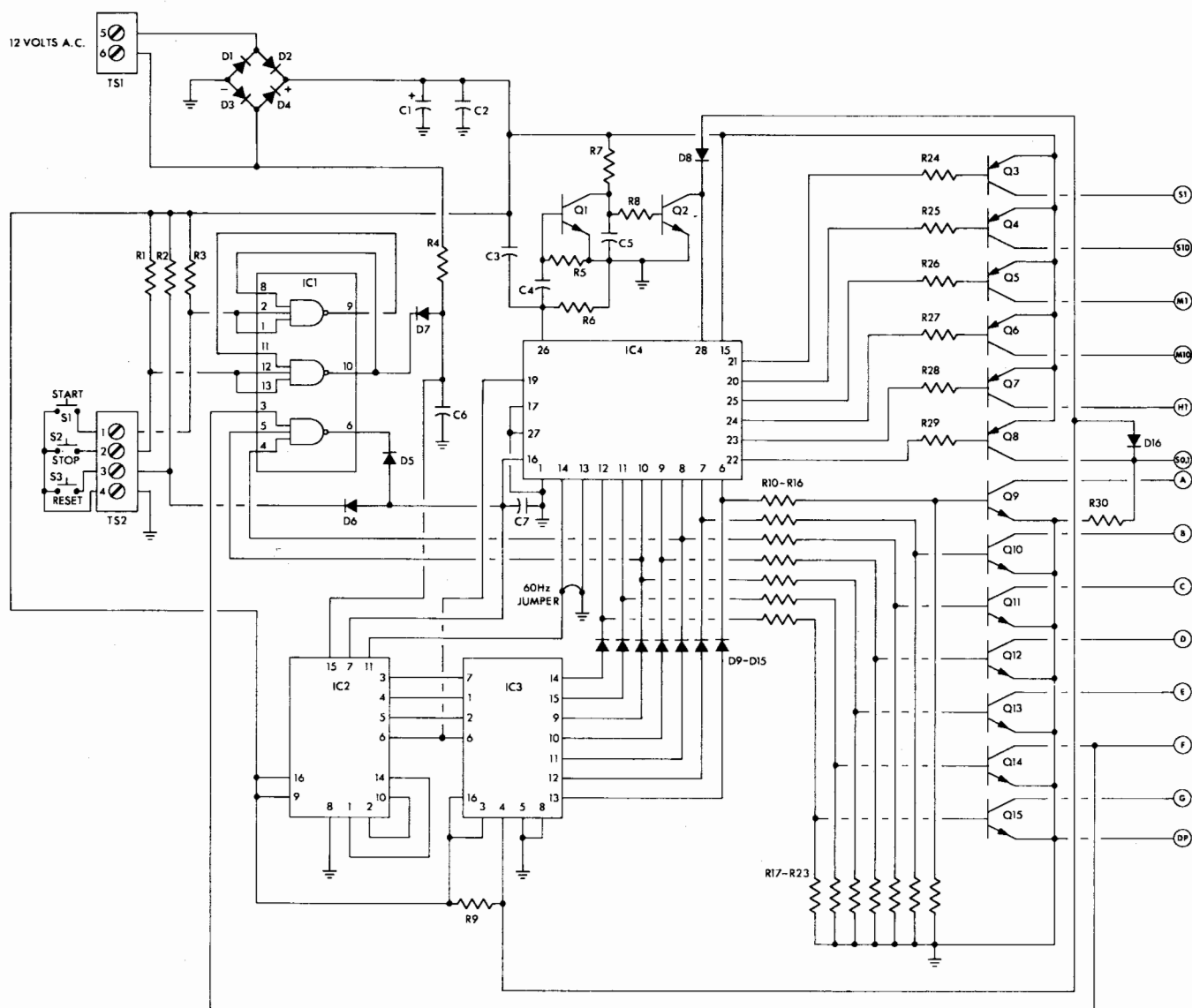

Times events to 10 hours in 0.1-second intervals.

BY MICHAEL S. ROBBINS



WOULD you like to know precisely how long a recording session runs; how long it takes to make one lap around the track; or how long that new amplifier has been cooking on the bench? Here is a new six-digit stopclock that can do it—counting and displaying elapsed time up to ten hours by tenths of a second.

The heart of the stopclock is the new National Semiconductor MM5309 PMOS integrated circuit. It is identical to the MM5311-5314 series of clock IC's with one important exception. The "hold" pin has been replaced by a "reset" pin, which allows all of the counters to be reset to zero. This means that all of the on-chip counters can be reset to zero as required in a stopclock.

In this project the 5309 is used with three other IC's to provide 0.1-s counting with stop, start, and reset controls. Power is provided by a 12-volt trans-

former, and either 60- or 50-Hz line power can be used. Although the 5309 has outputs for either a 12- or a 24-hour display, in this case we use only a 10-hour display with the initial zero blanked and the sixth digit used for displaying tenths of a second. (For example, the display is 9:00:00.0 instead of 09:00:00.0.)

Later in this article, we will describe some practical circuits to use in actuating the stopclock for timing different types of events.

How It Works. As shown in Fig. 1, the output of IC4 is in a multiplex seven-segment format, with each LED display turned on for one-sixth of the display cycle. The seven segment lines coming from Q9 through Q15 carry the segment information to all six digits (DIS1 through DIS6), while the six digit-enable lines coming from Q3 through Q8 turn on the digits one at a

time. The display cycle occurs at about a 1000-Hz rate, so that any display flicker is not noticeable.

Transistors Q1 and Q2 function as an interdigit blanking generator to prevent segment ghosting or afterglow. All segments are shut off for an instant before the digits are switched.

Since IC4 counts in seconds, IC2 and IC3 are required to provide a 0.1-s count. The first section of IC2 divides the 60-Hz line frequency down to 10 Hz, while the second section counts the 10-Hz pulses and delivers a BCD output. The count is repetitive, going from zero through nine. The reset line of IC2 (pin 7) is connected to the reset line of IC4 (pin 16) to insure that the two IC's count in synchronism after both are reset.

To display the output of IC2, the BCD signal must be converted to a seven-segment format. This is performed by IC3. To eliminate the need

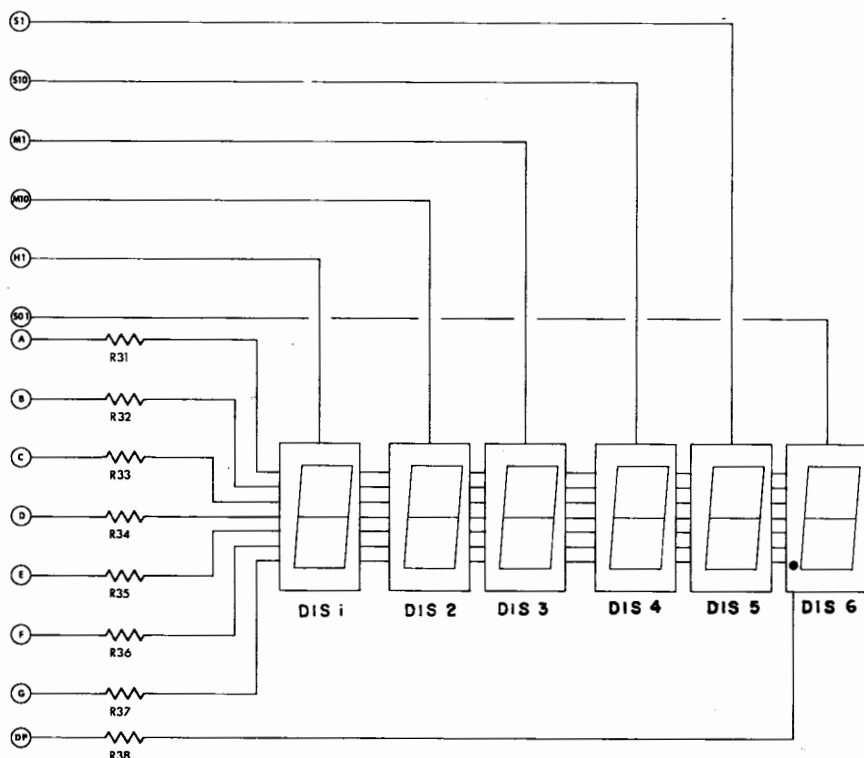

Fig. 1. Complete schematic of stopclock is shown above and on opposite page.

- C1—1000- μ F, 16-volt electrolytic capacitor
 - C2, C5—0.1- μ F, 20-volt disc capacitor
 - C3, C4, C7—0.01- μ F disc capacitor
 - C6—0.005- μ F disc capacitor
 - D1 through D4—1N4001 rectifier diode
 - D5 through D16—1N914 switching diode
 - IC1—CD4023AE (RCA) or MC14023CP (Motorola) integrated circuit
 - IC2—MC14566CP (Motorola) integrated circuit
 - IC3—MC14511CP (Motorola) integrated circuit
 - IC4—MM5309 (National) integrated circuit
 - DIS1 through DIS6—Seven-segment LED display (Litronix DL747 or similar)
 - Q1, Q2, Q9 through Q15—2N5172, MPS5172, or MPSA20 transistor
 - Q3 through Q8—2N4403 transistor
 - The following resistors a watt, 10%:
 - R1, R2, R3, R30—1000 ohms
 - R4, R7—100,000 ohms
 - R5, R17 through R23—10,000 ohms
 - R6—330,000 ohms
 - R8, R9—470,000 ohms
 - R10 through R16—2000 ohms
 - R24 through R29—470 ohms
 - R31 through R37—120 ohms
 - R38—270 ohms
 - S1, S2, S3—Normally open spst pushbutton switch
 - TS1—Two-lug screw-type terminal strip
 - TS2—Four-lug screw-type terminal strip
 - Misc.—Chassis box; printed circuit boards (2); 74 Molex Soldercons or one 28-pin, two 16-pin, and one 14-pin IC sockets; 2 small L brackets (optional); four spacers; four rubber feet; red acrylic display filter; machine hardware; hookup wire, solder, etc.
- Note: the following are available from Carinella Electronics, Inc., P.O. Box 727, Upland, CA 91786: etched and drilled main pc board No. DSC-1PC for \$7.95; etched and drilled display board No. DSC-1APC for \$6.95; complete kit of parts, including cabinet, hardware, etc., No. DCS-1K for \$79.95 plus \$2 shipping. California residents, please add 6% sales tax on all items. There are no kits available for the circuits shown in Fig. 4.

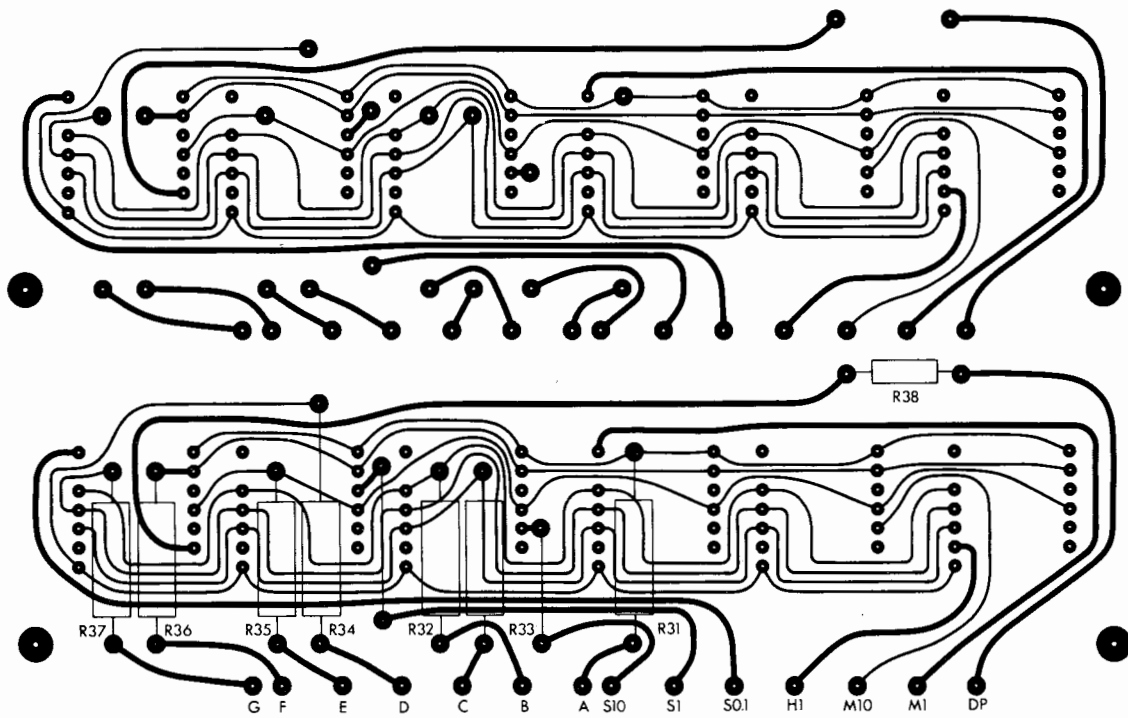
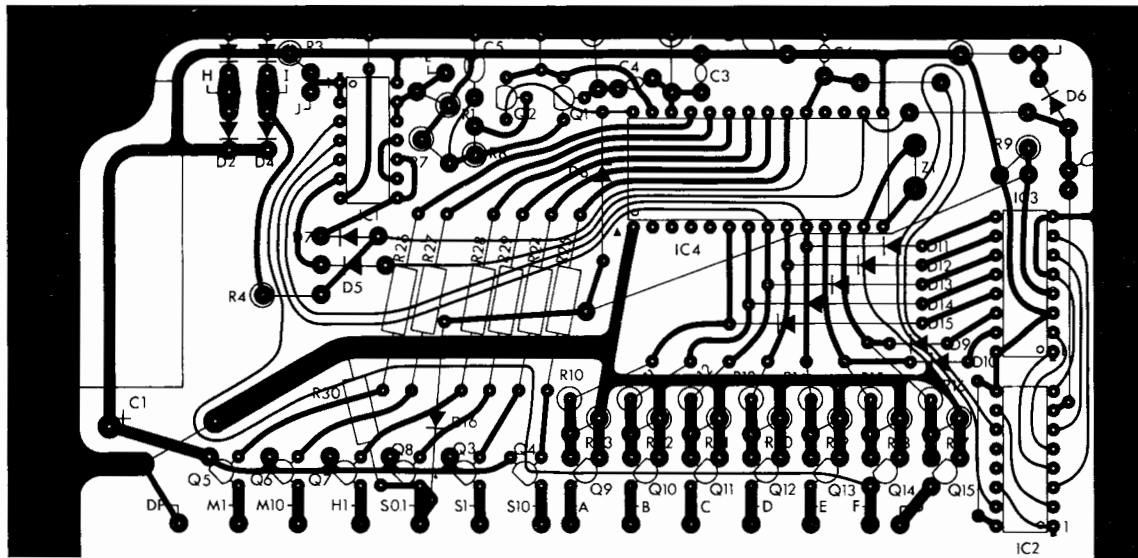
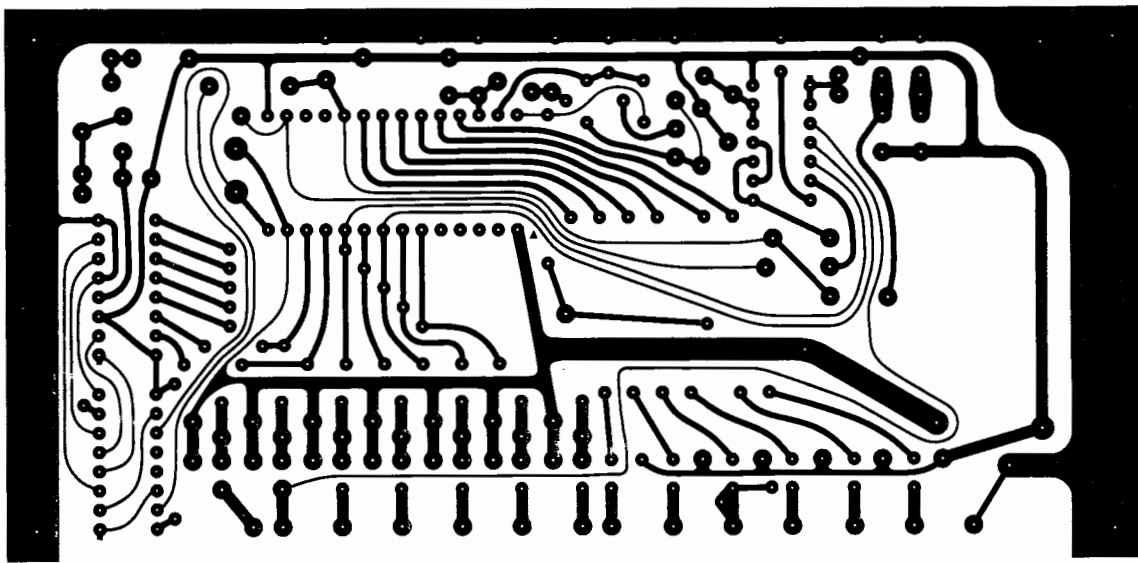

Fig. 2. Etching and drilling guides with component layout diagrams for the two pc boards.

for additional transistors to drive the 0.1-s display (*DIS6*), the outputs of *IC3* are connected through *D9* through *D15* to the outputs of *IC4*. Since *IC4* is off due to the leading-zero blanking interval when it would normally display the 10's of hours, this time slot can be used for the 0.1-s display. Thus, the *H10* output of *IC4* is used to turn on and off *IC3* and enable *DIS6*.

Now, what happens when the *H10* 10's of hours display is supposed to be on as it normally would be after a 9:59:59 count? Without *IC1*, *DIS6* would display a random character. One NAND gate in *IC1* is used to detect this random digit and reset *IC2* and *IC4* to zero. In this manner, the stop-clock is reset 0.2 second after the 10:00:00 count pulse, thus producing an effective timing range of 9:59:59.9 counts.

The other two gates in *IC1* are connected as an RS latch to turn on and off the time base. Operating *S2* causes pin 9 of *IC1* to drop to zero. Diode *D7* is then forward biased, preventing the ac signal from reaching *IC2* and *IC4*. Operating *S1* raises pin 9 to about 12 volts and effectively removes *D7* from the circuit, allowing the ac timing signal to reach the counters, and the count changes every 0.1 second.

Jumper *Z1* between pins 13 and 14 of *IC4* causes the input sections of *IC2* and *IC4* to divide by six for use on the 60-Hz power line. For 50-Hz operation, no jumper is needed.

Construction. The stopclock is best assembled on two printed circuit boards, the etching and drilling and component placement guides for which are shown in Fig. 2. The circuit is split between the main and display boards as shown by the two sections in Fig. 1.

Leaving installation of the IC's until last, wire the main board as shown, taking care to properly orient the filter capacitor, diodes, and transistors. Note in Fig. 3 that some resistors mount upright. Install Molex Soldercons® or regular IC sockets in the locations for the IC's, but don't install the IC's just yet.

Next, wire the display board as follows. First install and solder the resistors into place on the foil side of the board. Trim away excess lead lengths. Then install and solder into place the displays, *DIS1* through *DIS6*, on the blank side of the board. Interconnect the two boards with lengths of hookup

wire connected between similarly labelled pads on both boards. Solder 5" (12.7-cm) lengths of hookup wire to the pads identified in Fig. 2 by the letters H through L.

Fasten the display board to the main board with two small L brackets, threaded spacers, and machine screws; and mount another pair of spacers at the back of the main board. Then mount the entire assembly inside the chassis box, via the spacers, with four machine screws and lockwashers. Glue a red acrylic filter behind the front panel of the chassis box over the display "window." Then mount *TS1* and *TS2* on the rear panel of the box and *S1*, *S2*, and *S3* on the top.

Connect and solder the free ends of the wires coming from holes H and I to the lugs of *TS1* and the free ends of the J, K, L, and M wires to lugs 3, 6, 4, and 5, respectively of *TS2*. Solder 5" lengths of hookup wire to each of the lugs on *TS2* and wire them to the switches as shown in Fig. 1. Label *TS1* 12 VOLTS AC and lugs 3 through 6 on *TS2* STOP, START, RESET, and GROUND, respectively. Then label switches *S1*, *S2*, and *S3* STOP, START, and RESET, respectively.

Practicing the usual precautions for handling MOS devices, install the IC's in their respective locations via the Soldercons or sockets. Make certain that you orient them properly. (On the case of each IC is a dot for easy identification of pin 1.)

Operation and Use. When power is first applied to the stopclock, random numbers will be displayed. Depressing RESET switch *S3* resets all displays to zero. When START switch *S1* is momentarily closed, the stopclock should begin counting at a 0.1-s rate and the *DIS6* digit should be a blur. Let the stopclock run for a few minutes. Then hit STOP switch *S2*. The display should immediately grind to a halt and remain locked onto the last count after releasing *S2*.

To be of any use as an events timer, the stopclock must be stopped and started in a manner that produces meaningful information. The simplest approach would be to use the switches on the top of the cabinet to initiate the count and stop it. For remote operation, an identical set of pushbutton switches can be connected to *TS2* (paralleling *S1*, *S2*, and *S3*) via a cable. The best way by far of tripping and stopping the count is to let the event being timed operate the stopclock.

Bear in mind that each of the three circuits operated by the pushbutton switches in Fig. 1 is held at +12 volts by *R1*, *R2*, and *R3*. To enable an input, the bottom ends of these resistors must be connected to ground. Therefore, any external switching device connected to *TS2* must have an on resistance of less than 100 ohms and an off resistance in excess of 10,000 ohms. In the momentary-on condition, the external switching device must be capable of handling 12 mA of current.

As shown in Fig. 4A, relay contacts operated by some remote device can be used to trip any one or more of the *S1*, *S2*, *S3* functions. The circuit is closed by applying energizing power to the relay coil. If the relay is a latching type (mechanical or electrical), some means must be provided to open its contacts after each closure.

Optoelectronic couplers make ideal interfaces for the stopclock whenever the controlling circuit is at a different voltage from that used in the timer's circuit or has potentially damaging spikes. An optoelectronic coupler consists of a light source (usually a LED) and a light sensor (usually a phototransistor) facing each other in a light-tight case. The source and sensor are electrically isolated from each other. The Motorola 4N28 optoisolator, one of the more common types available, is shown connected to *TS2* on the stopclock in Fig. 4B. A separate optoisolator circuit can be used on each of the START, STOP, and RESET inputs. Each is separately tripped by momentarily applying a dc voltage to the source circuit.

The circuit in Fig. 4C can be used to

Fig. 3. Photo of internal layout. Note some resistors are vertical.

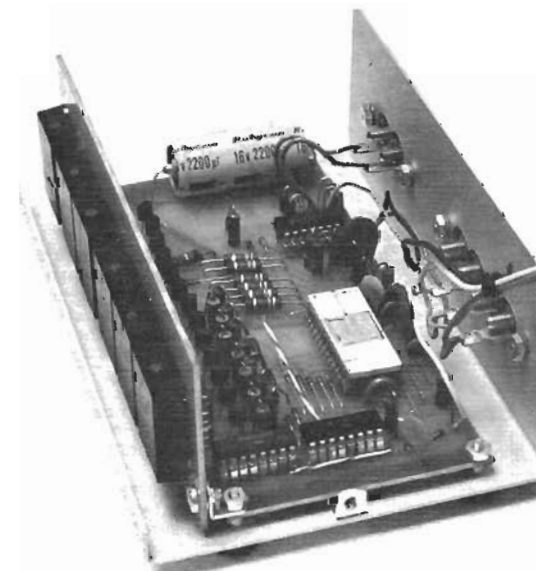

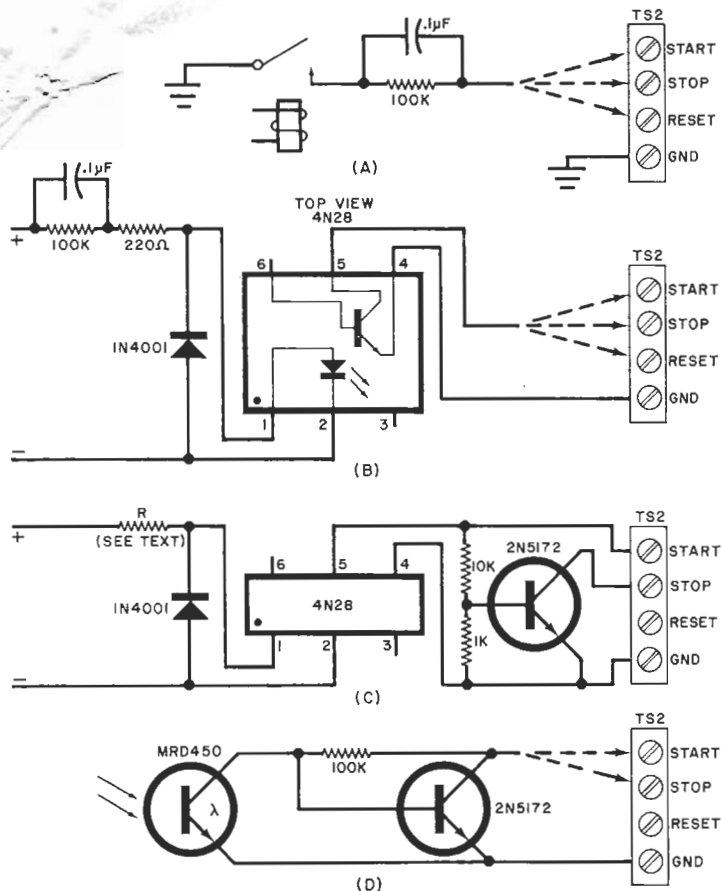
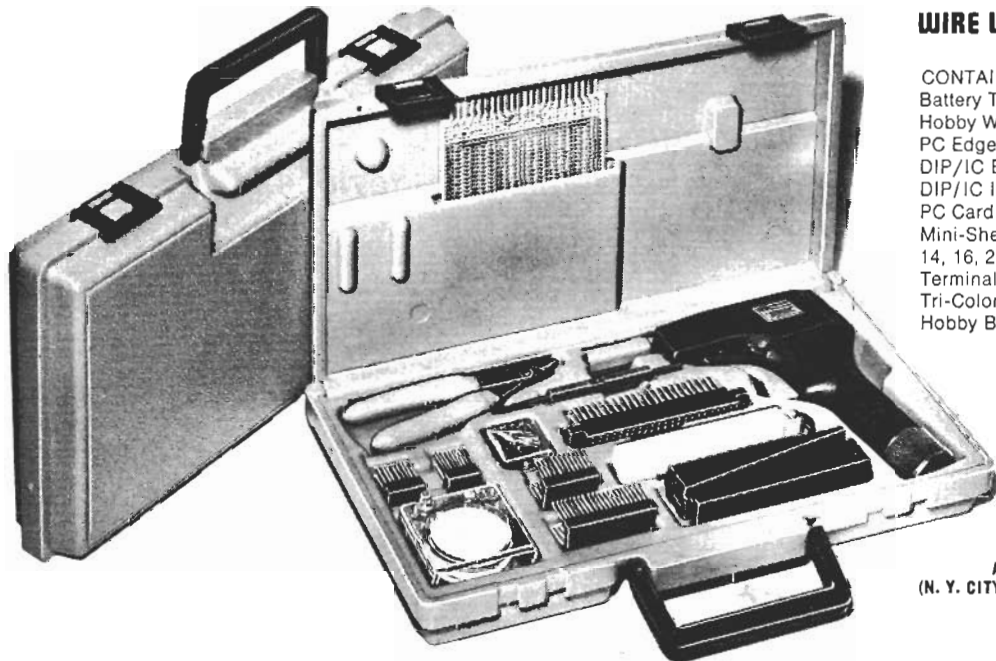

Fig. 4. Stopclock can be operated by a relay (A); an optoisolator (B and C); or a phototransistor (C).

measure running (or on) times. Resistor R should be selected to limit the current through the diode to about 40 mA. For example, to measure the running time of a battery-powered cassette recorder that has a 12-volt dc motor, the value selected for the resistor in ohms is equal to $(V-1.2)/A$, where $V=12$ volts and $A=40$ mA. In this case, $R=270$ ohms. The circuit connects across the tape recorder's motor.

The length of time it takes a vehicle (including toy trains and cars) to traverse a prescribed distance is often of interest. Light-beam tripping is a convenient way of starting and stopping the count. The circuit for accomplishing this is shown in Fig. 4D. Almost any type of light source, including an ordinary flashlight, can be used in this scheme. Depending on the distance between the light source and phototransistor, it may be necessary to use lenses to focus the beam. (Lenses may not be necessary in timing toys unless the distance is more than a few inches.) Although a Motorola MRD450 phototransistor is specified in the diagram, the value of the resistor can be adjusted to allow the circuit to accommodate just about any other phototransistor. ♦

ok wire wrapping center ok



WIRE WRAPPING KIT WK-5

CONTAINS:
 Battery Tool BW-630
 Hobby Wrap Tool WSU-30 M
 PC Edge Connector CON-1
 DIP/IC Extractor Tool EX-1
 DIP/IC Insertion Tool INS-1416
 PC Card Guides & Brackets TRS-2
 Mini-Shear with Safety Clip SP-152
 14, 16, 24 and 40 DIP Sockets
 Terminals WWT-1
 Tri-Color Wire Dispenser WD-30-TRI
 Hobby Board H-PCB-1

\$74.95

ADD \$1.00 FOR SHIPPING
 (N. Y. CITY AND STATE RESIDENTS ADD TAX)

OK MACHINE & TOOL CORPORATION

3455 Conner St., Bronx, N.Y. 10475 (212) 994-6600 / Telex 125091