

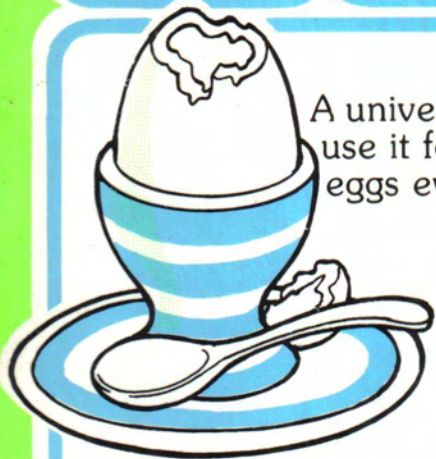

**ONLY**  
**\$6.95** \*

# DICK SMITH'S FUN WAY INTO ELECTRONICS Volume 2



A universal timer:  
use it for perfect  
eggs every time!

**Educational  
& Safe**

A wireless microphone:  
build this simple transmitter  
and receive it on any FM  
radio. It's simple!

**PLUS:**  
How to solder  
How to use a  
multimeter  
How to make  
printed circuits

And much  
more!

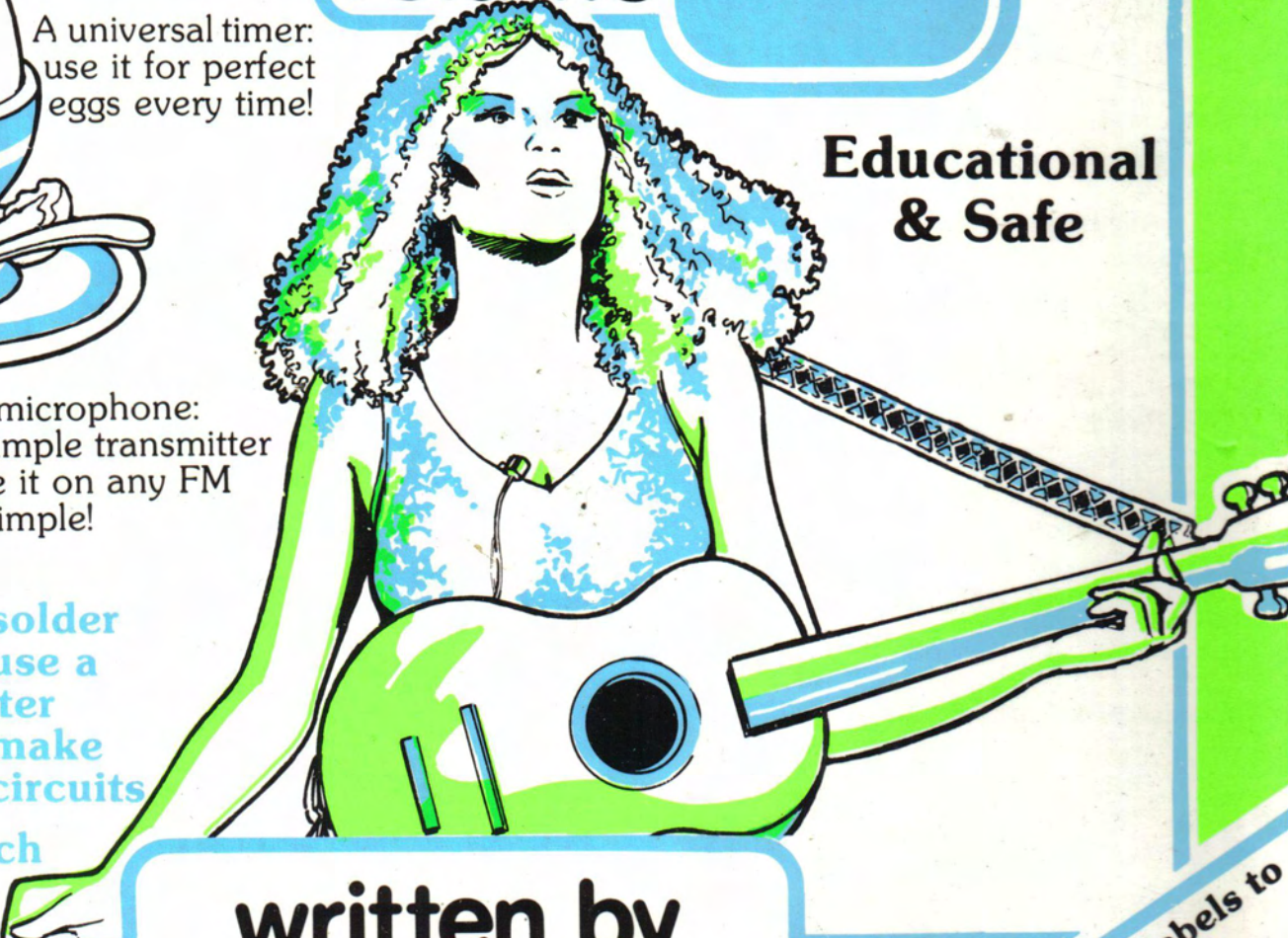

written by  
**DICK SMITH**

**12th  
printing**

Includes pre-printed labels to  
give your projects a  
**PROFESSIONAL  
FINISH**

By the same author:

Australian CB Radio Handbook  
Australian Amateur Radio Handbook  
Fun Way Into Electronics, Volume One

First Published 1980  
Second Printing 1980  
Third Printing 1981  
Fourth Printing 1981  
Fifth Printing 1982  
Sixth Printing 1983  
Seventh Printing 1983  
Eighth Printing 1984  
Ninth Printing 1984  
Tenth Printing 1985  
Eleventh Printing 1985  
Twelfth Printing 1985

by Dick Smith Management Pty Ltd  
Cnr Lane Cove Road and Waterloo Road,  
North Ryde, NSW, 2113.

Distributed by  
Dick Smith Distributors  
Cnr Lane Cove Road and Waterloo Road,  
North Ryde, NSW, 2113

National Library of Australia Card Number  
and ISBN 0 9595080 1 5

Printed in Australia by  
The Dominion Press-Hedges & Bell,  
Maryborough, 3465

**\*Recommended price only**

All rights reserved. No part of this publication may be reproduced or transmitted in any form or by any means, electronic or mechanical, including photo-copying, recording or by any information storage and retrieval system, without permission in writing from the publisher.

# contents

Introduction .....	5
A place to work .....	6
The tools you will need .....	7
The components we use .....	8
How to read component codes .....	18
How to read circuit diagrams .....	20
Basic circuit laws .....	21
Project assembly hints and tips .....	22
Learning to solder .....	24
Controlling other circuits with relays .....	27
<b>The projects:</b>	
1: The multi-purpose flashing LED .....	28
2: Ding Dong Doorbell .....	32
3: Morse Code Trainer .....	36
4: Universal Timer .....	40
5: Electronic Dice .....	44
6: Monophonic Organ .....	48
7: Pocket Transistor Radio .....	52
8: Touch Switch .....	56
9: Mosquito Repeller .....	60
10: Simple Audio Amplifier .....	64
11: FM Wireless Microphone .....	68
12: Light Activated Switch .....	72
13: Pipe and Metal Locator .....	76
14: Sound Switch .....	80
15: Home and Car Burglar Alarm .....	84
16: Electronic Siren .....	90
17: LED Audio Level Display .....	94
18: Home Intercom .....	98
19: LED Digital Counter Module .....	102
20: IC Shortwave Receiver .....	108
<b>Understanding Electronics:</b>	
What if I have the wrong transistor? .....	71
Working with Ohm's Law .....	75
The Binary System .....	107
How to use your multimeter .....	112
Understanding Radio .....	114
How to make Printed Circuit Boards .....	117
The technical terms we use .....	120
<b>Milestones in Electronics:</b>	
The birth of the transistor .....	35
The superheterodyne .....	35
The integrated circuit .....	58
What is a valve .....	63
The Phase-Locked-Loop .....	83
The Valve Oscillator .....	93
The Flip-Flop .....	93
Automatic Gain Control .....	93
Negative Feedback .....	93
<b>Pioneers in Electronics:</b>	
Samuel Morse .....	38
Michael Faraday .....	43
Thomas Edison .....	51
Guglielmo Marconi .....	55
Edwin Armstrong .....	55
Vladimir Zworykin .....	79
Cut-out front panel labels and templates .....	123 - 128

# welcome to my fun way into electronics volume two

*If you have worked your way through my first Fun Way book you will already have a good basic understanding of many electronic components and what they do. And I'm sure you have learned a lot, and had a lot of fun doing it.*

*With this new Fun Way book we continue the fun and learning with a host of fascinating, instructional and very useful projects.*

*You will learn how to make and solder your own printed circuit boards – the same type of boards that are used in even the most complex electronic equipment in the world today. You will learn how to combine several different projects in various ways to achieve other practical and useful circuits.*

*In fact, the most important thing about the projects I've chosen for this book is that they all make useful items in their own way.*

*You will also learn how to use a multimeter properly – one of the most important pieces of test equipment, and one that every hobbyist should know how to use.*

*I hope this book gives you an even greater interest in the wonderful world of electronics: a science that is booming and must continue to boom in every way. Those who understand electronics today will be best able to cope with the ever-increasing technological world of tomorrow.*

*From the letters I've had from readers of Fun Way One, I know you enjoyed building those projects. I hope you will enjoy building the projects in this book just as much.*

*Have fun!*

*Dick Smith*  
VK2ZIP

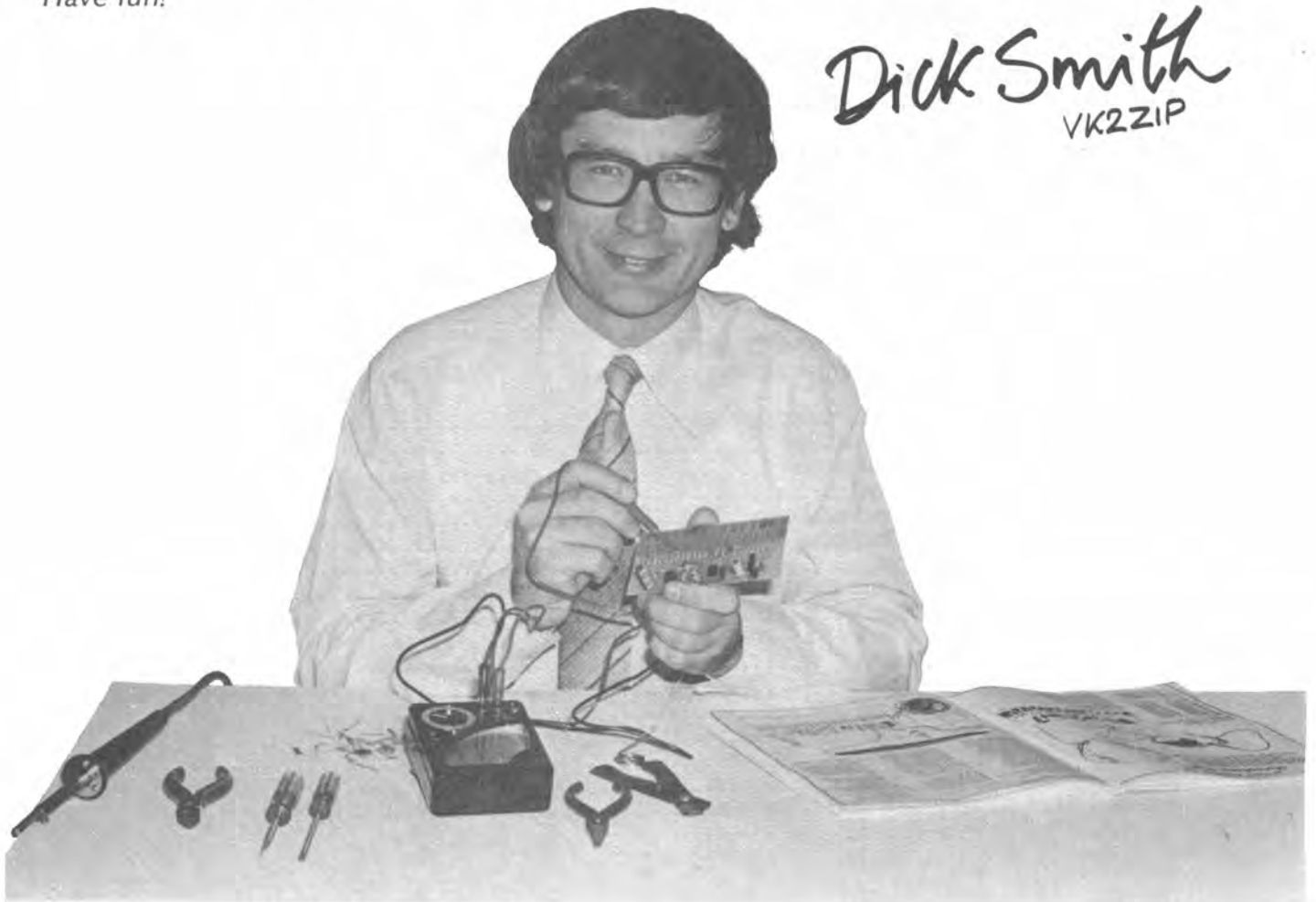

# Introduction . . .

Fairly obviously, this book is intended to be a follow-up to 'Dick Smith's Fun Way into Electronics', published in 1979.

If you are a complete beginner in electronics, we recommend that you invest in 'Fun Way 1' before commencing the projects described in 'Fun Way 2'. The level of the first 'Fun Way' is much simpler than the projects we describe here.

Notwithstanding the above, 'Fun Way 2' is designed to stand on its own. It would be possible for a complete beginner to successfully construct any of the projects in this book, simply by following the instructions supplied, and carefully noting the position of each component as shown on the printed circuit board layout.

Some of the information in Fun Way 1 has been repeated (and, where necessary, revised and expanded) so that reference to Fun Way 1 is not necessary.

A radical difference between the two books is our use of printed circuit boards for the projects in Fun Way 2. Of course, this requires soldering skills: but don't worry if you have not soldered before. We show you how to solder properly and, when you do make mistakes, how to recognise them and correct them.

Don't be scared by the printed circuit boards and the apparent complexity

of the circuits. 'PCBs' (as they are commonly called) actually make construction very much easier, with far less chance for error than with other methods.

The PCB's are designed to suit the components used – so if a component doesn't fit properly where you think it is supposed to go, there could be something wrong. Of course, with the thousands of different manufacturers of components these days, some components may be supplied which don't quite fit the holes properly (even though they are correct). Unfortunately, this is unavoidable – the component will normally fit with a bit of determination. But at least when a component doesn't fit you are made aware of possible problems!

Apart from soldering, the first twenty pages or so of this book contain lots of valuable information and tips which you will find very useful not only building these projects, but later on too. We suggest you read these pages thoroughly before embarking on any projects. If you're unsure of any technical terms you might come across, there is a full glossary starting on page 120.

We haven't stopped with 20 projects and tips on building projects, either. In Fun Way 2 we will introduce you to some of the people who made electronics what it is today. Some of the names will be familiar to you,

some probably not. But each person made a huge contribution to our electronic world.

We'll also tell you about some of the discoveries these, and other pioneers made in 'Milestones in Electronics'. And for a generation that has seen the virtual demise of the 'valve', we'll explain what it is, and how it was 'discovered' – along with the familiar transistor and integrated circuit of today.

Of special interest to all experimenters is the multimeter: one of the handiest pieces of test gear you can own. The trouble is, not many beginners know how to use their multimeters – often ending up with a charred mess when they do things like plugging in to 240 volts on a resistance scale!

We have included a special section on the multimeter: not only how to use it properly, but how it works.

If you have the 'Fun Way 1' book you will recall the cut-out project overlays in the back of the book. In Fun Way 2 these are not required because we use printed circuit boards. Instead we have designed attractive labels which you can cut out, and glue onto the front panels of your projects for a really 'professional' appearance.

As you can see, there is a lot more in 'Fun Way 2' than 'Fun Way 1' (it is nearly twice as thick!) Good reading, good constructing . . . and **have fun!**

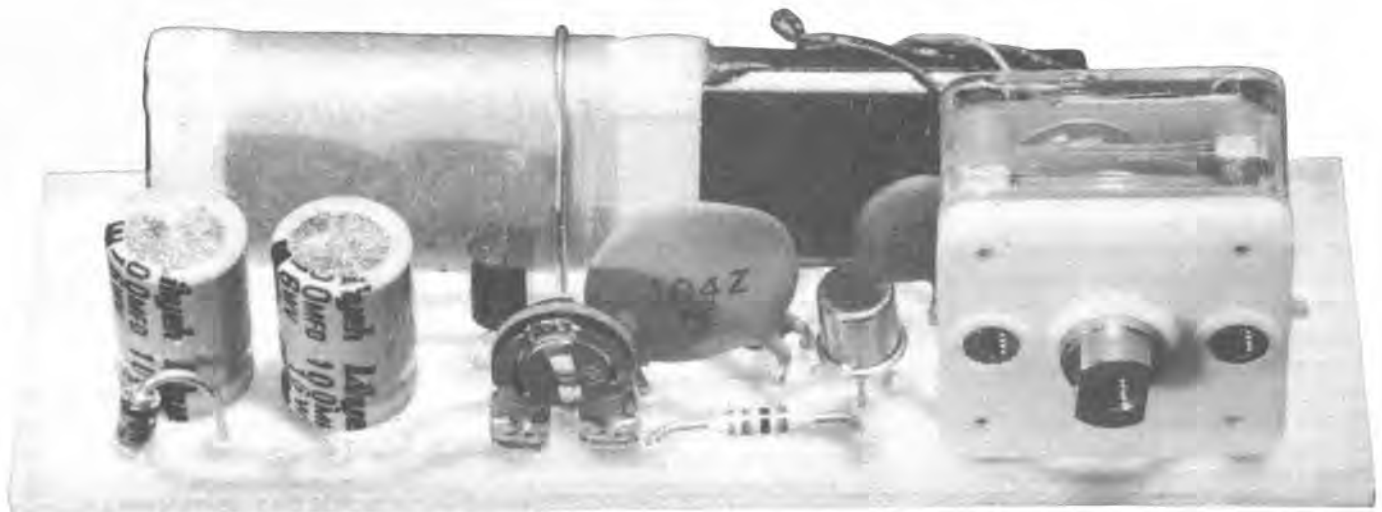

# A place to work. . . .

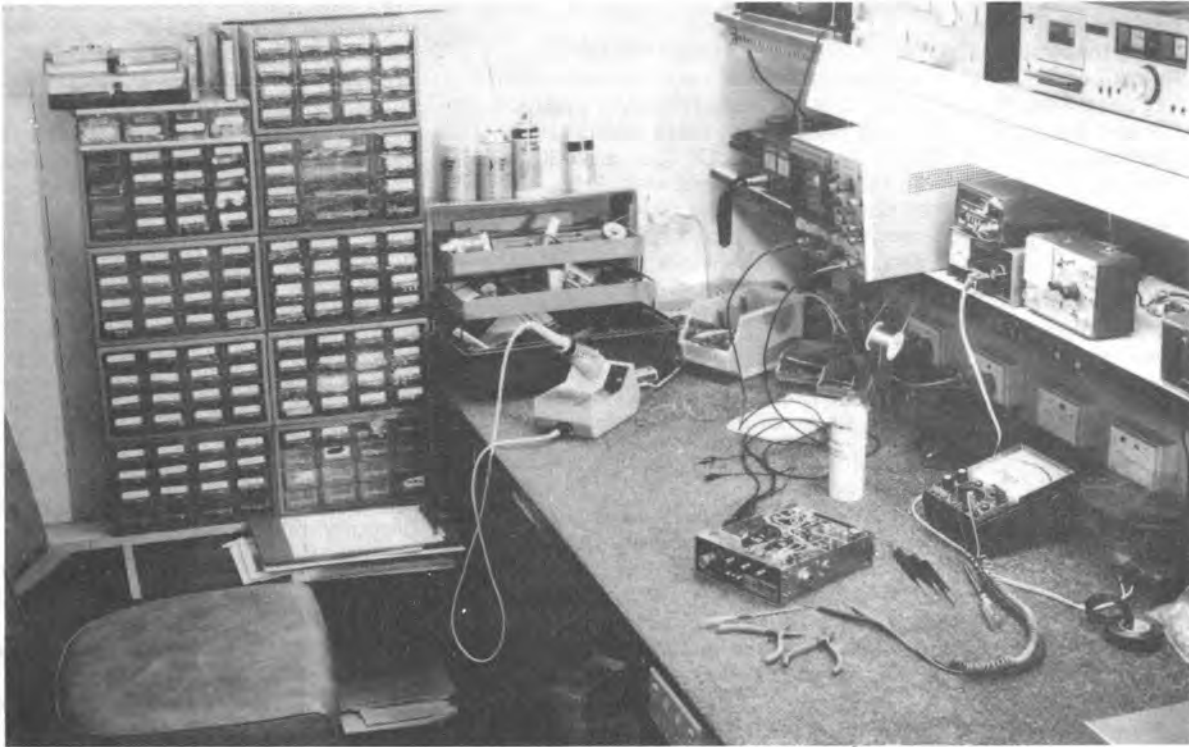

Figure 1

If you've had any sort of hobby before, you may already have your own corner with a bench, lighting etc. But if you haven't, you'll need an area that meets certain requirements of space, light and safety.

Adequate space is required so that you can work without your work area becoming cluttered. At the same time your tools and components should be within easy reach. The work bench pictured in Fig.1 is just one of several in the Dick Smith Electronics Service Department and is obviously ideal, but for the projects in this book an old table or even a board set up on the kitchen table would be adequate (See Fig.2). In fact it is usually best to start with a fairly modest setup. Then you can gradually build it up as you learn in what direction your interest will develop and what specialised tools and equipment you'll need.

As most of your projects use very small components you'll need plenty of light. If most of your work is done during the day, try and place your bench near a window as natural light is the best. For night work a fluorescent tube or portable desk lamp should be placed over the bench so that it shines on the job and not in your eyes.



Figure 2

From a safety point of view you need to be sure that your hot soldering iron cannot burn things (including yourself), and that any dangerous voltages and corrosive materials cannot be accidentally contacted. These cautions apply especially if you are working in your kitchen or living area and there are small children about. The work board shown in Fig.2 has a good firm soldering iron stand (don't use an ashtray or similar item that could be knocked over), a small vyce

for holding printed circuit boards while you solder and a large enough work space to prevent the table from being burnt.

Add a few small trays to hold components so that they don't fall on the floor to get lost, and the picture is just about complete. Except for your basic hand tools, which we will discuss in **TOOLS YOU WILL NEED** —

# The tools you will need. . .

With any job, you need the right tools to do it correctly. Always buy the best tools you can afford, as the few cents you save at first could make it more difficult to do a good job. Not only that but you'll probably have to spend more for new tools in a short time, as the cheaper tools wear out faster.

**Soldering iron:** the iron shown is the Dick Smith General Purpose Iron (Cat. T-1300) 240V/25 watts, with a chisel shaped bit. This is an ideal iron for the projects in this book and for most other electronic work. (See 'How to Solder')

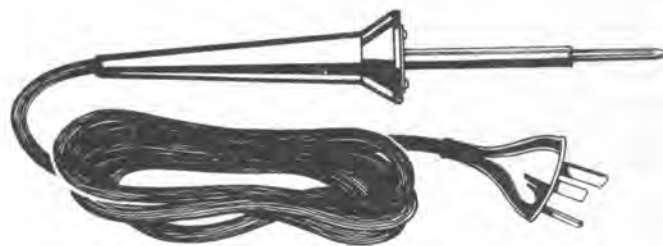

Dick Smith General Purpose Iron  
Cat. T-1300

**Cutters:** (Cat. T-3561) these cutters are economically priced but are of good quality and a most useful tool for all electronics work.

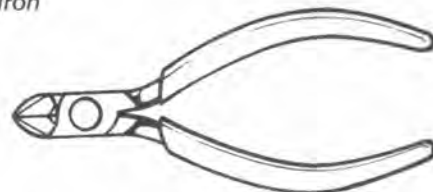

Cutters Cat. T-3561

**Long nose pliers:** (Cat. T-3562) these pliers are used for holding components, twisting or bending wires and even as heatsinks.

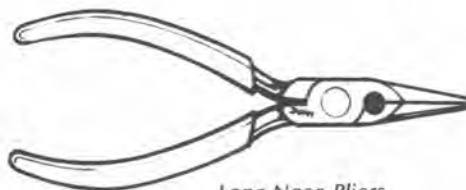

Long Nose Pliers  
Cat. T-3562

**Wire strippers:** (Cat. T-3630) as the name suggests these are used for stripping the insulation from wires before terminations are made.



Tweezers Cat. T-4620

**Tweezers:** (Cat. T-4620) for holding small components, or fishing out parts that have dropped into some inaccessible place.



Pearl Catch Cat. T-4660

**Self holding scissor clamps:** (Cat. T-3690) and pearl catch (Cat. T-4660) also available.

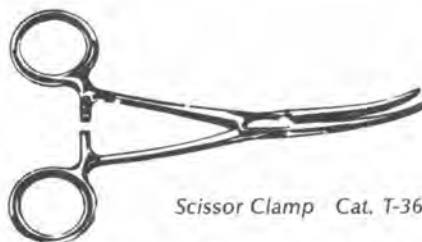

Scissor Clamp Cat. T-3690

**Heatsink clip set:** (Cat. T-2620) designed to clip on to component leads to prevent heat damage when soldering.

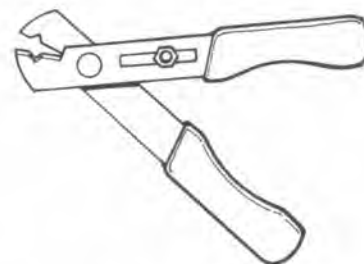

Wire Strippers Cat. T-3630

**Screwdrivers:** Small (Cat. T-4070), for knob screws and other general purpose hobby use.

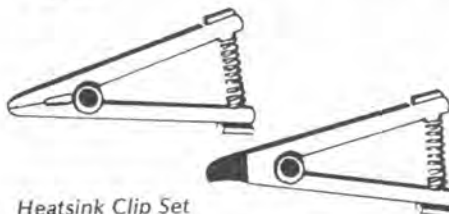

Heatsink Clip Set  
Cat. T-2620

Medium (Cat. T-4090), with a long (150mm) blade which enables you to reach inaccessible places. Fits a huge range of screw sizes.

Phillips (Cat. T-4040), to fit a wide range of sizes of Phillips head screws (e.g., on Zippy box lids).



Medium Screwdriver Cat. T-4090

**Multitester:** (Cat. Q-1020) ideal test meter for the projects in this book. Has 15 very useful ranges.



Phillips Head Screwdriver  
Cat. T-4040



Multitester Cat. Q-1020

For a complete range of tools and prices, see the latest Dick Smith Electronics Catalogue.

Take care of your tools by wiping them clean after use and storing them carefully between projects.

# COMPONENTS YOU WILL USE IN THESE PROJECTS...

The symbols we have shown next to the components in the component descriptions are standard symbols used, with minor variations, throughout Australia. Some countries, particularly European, use different symbols than we do, but it doesn't take too long before you can work out what any symbol means. First of all, become fully conversant with the symbols we use in Australia, and you should have no troubles.

One problem which beginners – and even experts – often have when looking at circuit diagrams is that some people use different methods of marking connections and cross-overs on circuits. Two circuits, side by side, may use the same thing to mean opposites! We have used the standard system of showing joined lines with a dot, and cross-overs with a loop indicating a cross-over. These are probably the easiest to understand.

If you find a circuit which uses a different system, just remember that it will be standard throughout the circuit diagram. So look for an area which you know must have joins and cross-overs and, with that information, you'll be able to work out the circuit in no time at all!!

COMPONENT	WHAT IT DOES	WHAT IT LOOKS LIKE	CIRCUIT SYMBOL
<b>BATTERIES &amp; BATTERY CLIP:</b>	<p>The batteries we use in the projects described in this book are DRY CELLS –i.e. they produce an electromotive force or voltage through the chemical reaction between a relatively dry paste of chemicals, the zinc case of the battery and a carbon rod. Thus they may be turned upside down without fear of leakage. However, they may NOT be recharged in the way ACCUMULATORS can be (the type you find in motor vehicles).</p> <p>All batteries are polarised, with a positive and a negative terminal, and must not be connected the wrong way around in a circuit.</p> <p>Most of the circuits have been designed to use the readily available type 216 9 volt transistor radio battery (Dick Smith Cat. S-3001 or similar). These should be used with a battery clip (Cat P-6216) to prevent incorrect connection of the battery. This clip fits on only one way: the red lead is the positive, and the black lead is the negative.</p>		

## CAPACITORS:

Capacitors store electric charges. The higher the capacity, the more electric charge the capacitor can store. Capacitance is measured in microfarads (uF) and picofarads (pF).

Capacitors are marked with both their capacitance value and a voltage rating. If this voltage rating is exceeded, the capacitor can be seriously damaged. However, it is almost always permissible to use a capacitor with a **higher** voltage rating than the one called for. For example if a circuit specified a 1uF 10 volt capacitor, you could use a 1uF 15 volt, 50 volt or even 1000 volt (if you could find one!) without any problems. You could not, however, use a 1uF 9 volt or anything lower.

## POLYESTER CAPACITORS:

Often called 'greencaps' because they are usually green, these capacitors are used mainly in audio circuits. They range in value from a few microfarads to around .001uF. They are not polarised.





## DISC CERAMIC CAPACITORS:

These look like small discs – hence the name. They range in value from 0.47 $\mu$ F or so down to 1pF. You can often use a disc ceramic when a polyester is called for, but the reverse is not always the case. They are not polarised.



## ELECTROLYTIC CAPACITORS: "Electrolytics" for short!

Electrolytics are polarised and they are normally marked so that you cannot mix up the connections. They range in value from around 0.5 $\mu$ F up to hundreds of thousands of microfarads. They have two leads, which may both come from the same end, or one from each end. The type that has two leads protruding from one end is especially designed to be used on printed circuit boards, taking up less space. Both types have the same symbol – a capacitor symbol with a plus and minus indicating polarity.

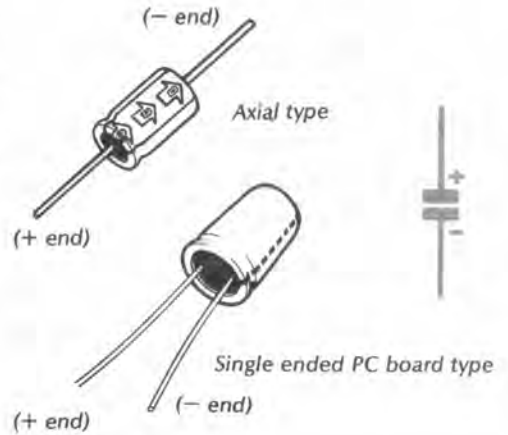

## TANTALUM CAPACITORS:

These capacitors offer the great advantage of a high capacity in a very small pack and their radial leads make them ideal for use on PC Boards. Tantalum capacitors are commonly available in values from 0.1 $\mu$ F to 100 $\mu$ F and are usually polarised. They may be used in place of electrolytic capacitors of the same values.



## VARIABLE CAPACITORS:

The variable capacitors we use in the projects in this book have values ranging from 1.5pF to 20pF, through to a range or 60pF to 160pF. The smaller values apply to 'TRIMMER CAPACITORS' which are used mainly for 'fine tuning' a larger fixed value capacitor. The larger range is typical of the VARIABLE CAPACITORS found in transistor radios, used to tune different stations.

These variable capacitors have three terminals; in our projects we use only two. Follow the instructions provided for each particular project. In other circuits, all three terminals may be used, and the capacitor must be connected the correct way around.



## COILS:

Simply a number of 'turns' of a conductor (usually insulated copper wire) to increase a property called 'inductance' (see technical terms).

The coil's characteristics will change depending on how many turns it has, how close together they are, their diameter and what they are wound on. For example, a number of turns on a wooden dowel will not have nearly as much inductance as the same number of turns wound around an iron bar of similar diameter.

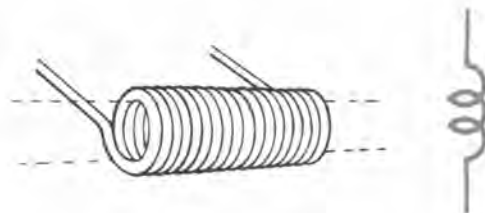

## CRYSTAL EARPHONE & MICROPHONE:

This earphone converts electric voltages into sound waves by connecting them across a piece of crystal material which is piezoelectric: its shape changes when a voltage is applied. Crystal earphones are of very high resistance or 'impedance', but are not polarised. The piezoelectric behaviour of the crystal in these earphones is two-way: so it can also be used "back-to-front" to convert sound waves back to tiny voltages, i.e., as a crystal microphone.



Earphone  
Symbol

## MAGNETIC EARPHONE & MICROPHONE:

These earphones are of very low impedance (see technical terms) and convert small electric currents into sound waves by using a coil, permanent magnet and a diaphragm. They are not polarised.

As with the crystal earphone, the magnetic earphone may be used 'back-to-front', as a microphone. You do this by speaking into the part you would normally place in your ear.



Microphone  
Symbol

## DIODES:

There are a number of different types of diodes, all with their various differences but with one basic feature in common: they let current flow in one direction only. Diodes are therefore, polarised and must be placed correctly in circuits or they will not work. If wired in the wrong way around they can be damaged, as well as causing damage in other parts of the circuit. The 'one way' feature of the diode is used in various ways and you will be introduced to several of these in this book.

## POWER DIODES:

Diodes are frequently used as 'rectifiers' to change alternating current to pulsating direct current, or with smoothing, to direct current. Generally diodes for this use are known as POWER DIODES, such as type IN4001 or similar (Dick Smith Cat. Z-3202). As seen in FUN WAY INTO ELECTRONICS VOL 1, these may be used simply as a reverse polarity protection device to protect the circuit in case the battery is inadvertently connected the wrong way around.



*The diodes supplied in kits will normally look like this, but may be marked differently to those specified. For these kits, any of the '1N40...' series of diodes are suitable.*

## SIGNAL DIODES:

Diodes are also used in the detection circuits of some radio receivers, in which case they need to have a very low voltage drop. These diodes are called 'SIGNAL DIODES' (type OA91 or similar, Dick Smith Cat. Z-3040).



## ZENER DIODES:

ZENER DIODES (Cat. Z-3413 or similar depending on value). As with the normal diode, the zener diode conducts in one direction and blocks current in the other direction. But the zener diode blocks current only up to a certain voltage, when the reverse resistance drops to a low value and the diode conducts, in the normally reverse direction. When this occurs, the voltage drop of the diode remains almost constant, over a wide range of currents, so the zener diode can be used to "clamp" the maximum voltage that can occur in a circuit. The voltage of a zener diode may be preselected, and zener diodes are sold according to voltage. So you can buy a 6.2 volt "zener", or a 12V zener, and so on.

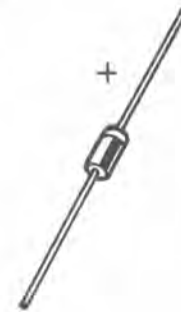

## LIGHT EMITTING DIODES:

Red  
(Dick Smith Cat. Z-4010)

Called LEDs for short, these do get upset with reverse polarity. When correctly connected, they glow brightly. Their polarity is shown in two ways: they normally have a longer lead for the anode, and the cathode is often marked by a slight flattening on the body of the LED adjacent to it.

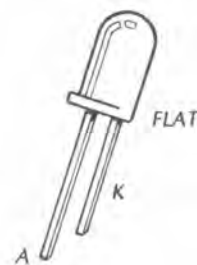

## LED DISPLAY:

(Dick Smith Cat. Z-4117)

Basically a number of LEDs arranged in a particular way to create a special effect. For example project 19 uses an LT-302 display which has 7 separate LEDs arranged in a figure-8 pattern. When power is applied to the display the numbers 0-9 can be obtained. This enables electrical signals to be directly converted to visual information. LEDs are used as displays for other purposes as well e.g. arrow signs, panel meters, etc.

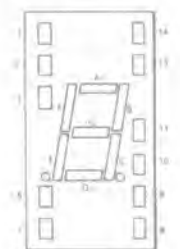

## FERRITE ROD AERIAL:

Small transistor radio type, two coils.  
(Dick Smith Cat. L-0520)

The ferrite rod aerial concentrates radio waves, in some cases eliminating the need for a separate aerial. Normally with two coils, typically they are coloured red and pink. However, this need not always be the case. The wire in these is very fine; care must be taken to avoid breaking it.

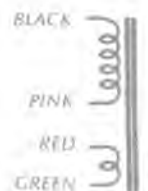
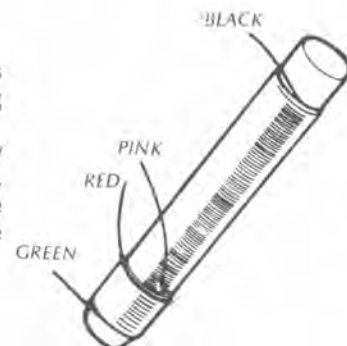

## HOOK-UP WIRE:

As the name implies, hook-up wire is the general term given to wire that is used to connect various parts of a circuit. The copper tracks on the printed circuit boards do much of the 'hook-up' work these days. This is not always practical, however as some components (speakers for example) can't be mounted on the PCB. In such a case you would use two pieces of hook-up wire to connect between the speaker and the PCB.

Hook-up wire is generally made up of many strands of fine wire (to aid flexibility), covered with insulating plastic. The thickness of hook-up wire depends on how much current it is expected to carry.



Wires joined



Wires not joined.  
(use insulated wire for at least one)

## INTEGRATED CIRCUITS:

As the name implies, a circuit that is **integrated** onto (and into) a tiny chip of almost pure silicon. The level of complexity of Integrated Circuits (or IC's as they are commonly known) varies enormously.

A simple "IC" can consist of just two transistors on the same chip of silicon. A more complex one can have over 100,000 transistors on the one chip. Technology in this area is improving all the time and as you read this line new and more complex IC's are being produced. For the purposes of construction in this book, however, we only have to consider their function i.e. what the whole IC **does** for us. Some IC's are complete amplifiers on a "chip" whilst others can be computers on a "chip". Shown below are the IC's that you will encounter in this book.

### "LINEAR" INTEGRATED CIRCUITS:

This is a general name given to IC's similar in nature to the ZN414 and 555 etc. Generally such IC's control, switch, process, modify or amplify etc., signals of an **analogue nature**. (See technical terms).

Linear IC's can be made in various ways using several transistor fabrication techniques. The technique of fabrication generally will not alter the **function** of the IC, but it will alter the performance. This is even more evident with Digital IC's (see below).

### TYPE ZN414:

(Dick Smith Cat. Z-6520)

This is a very special IC indeed. It is almost a complete radio on a chip! It consists of a series of amplifiers and a 'detector' (see technical terms).

It has only three connections viz: Earth, Input and Output and with the addition of a few external components and a battery you have a complete radio!

Make sure that you insert the component in circuit correctly as it is polarised. Note the metal tab.



### TYPE 555:

(Dick Smith Cat. Z-6145)

This is also a special IC. It is used mainly for timing applications\*. Note that it is in a different package to the ZN414.

This package is called "Dual-in-Line". In other words, two rows of pins, parallel to each other. In this case not all pins are used. Note the orientation (see "component marking".)

\*Changing the value of the few external components needed changes the timing characteristics of the 555.

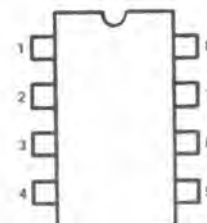

## "DIGITAL" INTEGRATED CIRCUITS:

Digital IC's as the name implies, switch, add to or subtract from, etc, signals of a **digital** nature (see technical terms). Digital IC's are the building blocks of all computers, as well as a lot of measuring instruments, control equipment, entertainment devices, etc. They process signals at an amazing speed, with incredible accuracy.

As technology in this area is changing rapidly, the production techniques have changed also. The basic function of the circuit elements may not have changed much, their performance certainly has. (See 'Milestones in electronics: the integrated circuit').

To make things just a little more complicated, we have used what is commonly regarded as a 'digital' IC in a 'linear' application in project 20: we don't switch the IC on and off as would a digital circuit, instead we use the area in between on and off – normally a 'taboo' area. To familiarise you with the technology of digital IC's we have deliberately designed projects in this book that use IC's that are made in different ways. You will find that some digital IC's are called 'TTL' and some 'CMOS'. These are acronyms for how the ICs are fabricated: TTL stands for Transistor-Transistor-Logic. TTL IC's were developed in the late 60's, TTL is very fast, but the IC's draw a lot of current making them uneconomic in large scale systems.

CMOS stands for Complementary Metal Oxide Semiconductor. This impressive sounding name simply describes the circuit configuration and the type of transistor used inside the IC. CMOS IC's operate over a wide voltage range, but are fragile compared to TTL. It is not necessary for you to have to know too much about the 'insides' of the IC's at this stage. You should know what the IC's function is in the circuit. However, (as mentioned above) the history of the IC is fascinating – and we have described some of this in this book. Digital IC's are represented in circuit diagrams as a rectangular shape or as separate symbols with their function diagrammatically represented. For example, if the IC is performing the function of an 'AND' gate (see technical terms) it would appear thus:



Finally, for the record, there are other types of digital IC's too. The acronyms for some of these are: RTL, DTL, ECL, N-MOS and P-MOS. If you don't know what these mean, don't worry at this stage! The way IC technology is moving, they may well all be history before too long anyway . . .

**LDR:**  
(Light Dependent Resistor)

See 'resistor'

**LED**  
(Light Emitting Diode)

See 'diodes'

**LOUDSPEAKER:**  
8 ohm type  
(Dick Smith Cat. C-2222)

Like the earphone the loudspeaker changes current into sound waves. Contrary to popular belief, a larger speaker will give more volume than a small speaker from the same source. If you can afford a larger speaker the results will be well worth the extra expense. The leads can be connected either way in our projects.



**LOUDSPEAKER AS A MICROPHONE:**

You can use a loudspeaker as a microphone by connecting an audio transformer to it. The 8 ohm side of the transformer (the two lead side) connects to the speaker terminals, while the outer two leads on the three lead side are used to go to the input of the amplifier, transmitter, etc.



## HORN TYPE LOUDSPEAKER:

(Dick Smith Cat. C-2705)

Similar to other loudspeakers in that they have a coil as the driver. The main difference is that they are enclosed in an "exponential" horn, usually made of metal. This has the effect of making the output from the speaker very directional but loud in that direction. Commonly used as PA (Public Address) speakers or burglar alarm components. Because of their construction they do not have a broad frequency response. (See technical terms). They are very efficient compared to an ordinary loudspeaker.

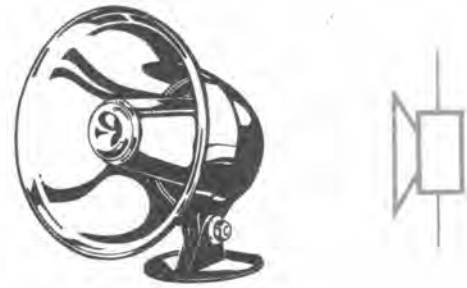

## MORSE KEY:

Economy model  
(Dick Smith Cat. D-7105)

A Morse 'key' is simply a switch which controls the current flowing to the circuit. When the key is pressed, current flows – and the tone sounds. The key can be adjusted to give a 'pitch' (the distance between the contacts) and a 'tension' (the force needed to press the key) that suits the operator best. The key is not polarised. The key can be used as an on/off switch in any of the projects simply by inserting it in series with the battery, in either the negative or the positive side.

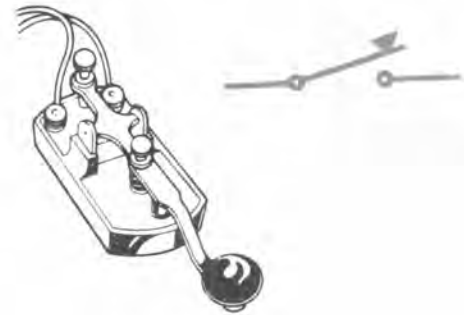

## MICROPHONES:

See also 'crystal microphone', 'magnetic microphone' and 'loudspeaker as a microphone'.

## ELECTRET MICROPHONE:

The electret microphone has capacitive plates with a small permanent electric charge between them. Because of this charge, any movement of the plates due to sound waves produces a tiny alternating voltage. Some types have an inbuilt preamplifier which requires a power supply.

3 Lead or 2 Lead

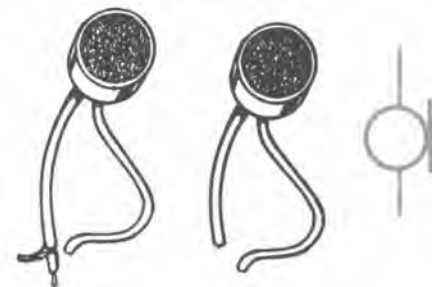

## 'PLUG-PACK' POWER SUPPLY:

(Dick Smith Cat. M-9525)

Strictly not a single component but a 'power supply'. They resemble a 3 pin mains plug except that they have a square body. Inside the body is a small transformer and other components which enable you to power your projects from the 240V mains, safely and cheaply. You can regard a 'plug pack' as a power supply component.

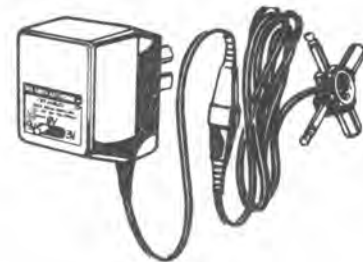

## PRINTED CIRCUIT BOARDS:

A flat piece of material around 1½mm thick, generally made of phenolic or fibreglass material. On one side (but sometimes both) is bonded a very thin sheet of copper. Parts of the copper are etched away to produce 'tracks', which form the conductors between components, which are soldered to them.

Called 'printed' circuit boards (or PCB's) because techniques similar to printing are used in their manufacture.



## RELAYS:

(Dick Smith Cat. S-7120)

These are simply switches that are operated by an electromagnet instead of by hand. This enables the switch to be operated from a remote locality, in any one of a number of ways. Relays allow very small currents to be used to switch huge amounts of power.

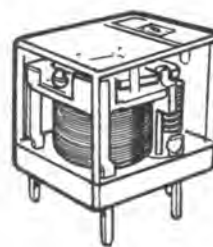

## RESISTORS:

Are neither insulators nor conductors: they are somewhere in between, allowing some current to flow. The lower the resistance, the more current can flow. Resistance is measured in ohms. Resistors are used to limit current to values which can be used by the various components; too much current and the components may be damaged.

Resistors also have a 'power' rating; they must not be called upon to pass too much current or this power rating is exceeded and the resistor may be damaged or destroyed. Our projects use resistors between a 1/4 and 1 watt power rating. However, like capacitor voltage ratings, it is in order to use higher rated components.

### FIXED VALUE RESISTORS:

Various values, 1/4 – 1 watt

Fixed value resistors are marked with a colour code. Refer to the colour code on page 19 so you will be able to identify each resistor used in these projects. Resistors are not polarised.



### VARIABLE RESISTORS:

or 'potentiometers'

A potentiometer is merely a fixed value resistor with special sliding arm which allows you to select as much of the resistance value as you want by turning a control shaft. Potentiometers therefore, have three terminals: one each connected to the ends of the 'resistor' element itself, and one connected to the sliding section. Sometimes an extra pair of terminals is provided on the rear of the case – this is an on/off switch, also actuated by the shaft. Potentiometers are sometimes polarised: check the circuit for connection details.

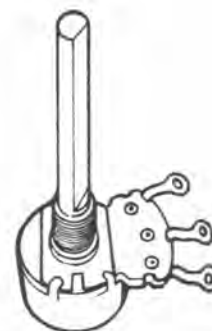

### LIGHT DEPENDENT RESISTOR:

(Dick Smith Cat. Z-4802)

Obviously, this resistor is effected by light. In its 'dark state' its resistance is very high – millions of ohms. In bright light, this falls to just a few hundred ohms. The resistance changes as the light level changes, therefore it is handy for monitoring light levels. It is not polarised.

3 Lead or 2 Lead



## SOLDER:

Broad name used to describe a material used for electrically bonding metals together. Usually made from an alloy of lead and tin, sometimes with traces of other metals. While common solder is 50% lead and 50% tin, solder used in most electronic work is generally 60% tin and 40% lead (or '60/40' solder).

Electronic solder usually has a fine thread of 'flux' running down the centre of the solder wire. This saves a separate fluxing operation and makes a neater, more reliable joint. When constructing the projects in this book, you should use fine solder (either 20 or 22 gauge) for best results.



## SPAGHETTI INSULATION:

Pack of various sizes.  
(Dick Smith Cat. W-4040)

Called 'spaghetti' because it is hollow like spaghetti, this is an insulator which may be used to slip over hook-up wire to give the wire more rigidity when used as 'probes'. Spaghetti insulation can also be used over tinned copper wire to insulate it if plastic covered wire is not available.



## SWITCHES:

Devices, (generally mechanical) capable of interrupting the flow of current through a circuit. They take an incredible variety of forms, shapes and sizes, depending on the job they are required to do. The simplest switch has just two terminals. When the switch is 'off' the terminals are not connected to each other; when the switch is 'on', a bar inside the switch shorts the terminals to each other.

Other switches may have a number of such terminals inside them (these are called 'multi pole' switches), while others may have a number of different terminals which are selected by various positions of the switch knob – diverting the current to various parts of the circuit. These are known as 'multi throw' switches. Yet other switches may be combinations of these types, or have springs which re-set them when released, etc.



Single Pole Single Throw

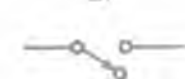
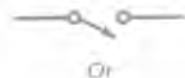

Double Pole Double Throw



Push Button



## TRANSFORMERS:

Audio matching types,  
8 ohms to 1k centre tapped  
(Dick Smith Cat. M-0216).  
3k to 3k centre tapped  
(Dick Smith Cat. M-0222)

The transformer transfers AC signals from one section of a circuit to another. At the same time it can also isolate DC (Direct Current) from the rest of the circuit.

The audio coupling transformer's main value to us in this book, however, is to **match the impedance** (see technical terms) of one part of the circuit to another.

Some transformers have a 'centre tap', which may or may not be used.



8 ohms to 1k centre tapped



3k to 3k centre tapped

## TRANSISTORS:

The word "Transistor" is actually another acronym – it stands for **Transfer-Resistor**. The original (and still most common) transistor type is the **Bipolar** transistor (see technical terms). They come in two versions, PNP and NPN. Both versions are used by us in this book. In one project we use what is called a Unijunction Transistor. This transistor was once very popular but not so much now. It is ideal for the particular application in project 9 though.

There are generally three leads on a transistor and each one must be connected in the circuit correctly in order for the transistor to operate. One lead is called the **base**, sometimes abbreviated in a schematic circuit diagram as 'B', the next lead is called the **collector**, abbreviated 'C' and the other lead is called the **emitter** abbreviated 'E'.

The unijunction transistor has (would you believe) an emitter and two bases B<sub>1</sub> and B<sub>2</sub>.

Transistors are used as either switches or amplifiers in this book.



**NPN TRANSISTOR:**  
DS548 or similar.  
(Dick Smith Cat. Z-1308)

An NPN transistor has a positive voltage on its collector and a negative voltage on its emitter. When a positive voltage (with respect to the emitter) is applied to the base the transistor begins to conduct by allowing current to flow through the collector/emitter circuit. The relatively small current flowing through the base circuit causes a much greater current to flow through the emitter/collector circuit. This phenomenon is called current gain. It is a measure of the transistors ability to **amplify**.

Note that the arrow in the diagram for the emitter points **out**.

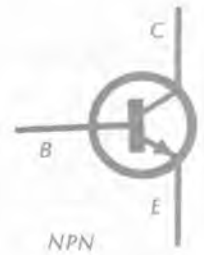

**PNP TRANSISTOR:**  
DS558 or similar.  
(Dick Smith Cat. Z-1348)

A PNP transistor does **exactly the same thing** as above except that it has a negative voltage on its collector and a positive voltage on its emitter. When a negative voltage (with respect to the emitter) is applied to the base, current will flow through the collector/emitter circuit. This time the current will flow in the opposite direction of course. You can instantly recognise which type of transistor you are dealing with in a circuit by the fact that the arrow points outwards on an NPN and inwards on a PNP. The transistor may be drawn upside down, back to front, or any way in a circuit – but the arrows will still point out for an NPN, in for a PNP.



**UNIUNCTION TRANSISTOR:**  
DS2646 or similar.  
(Dick Smith Cat. Z-1786)

This transistor consists of a tiny bar of N-doped Silicon material. A wire is bonded to each end of the bar. These connections are Base<sub>1</sub> and Base<sub>2</sub> respectively. A tiny speck of P-type Silicon material is alloyed into the bar between the ends but a little closer to B<sub>1</sub> end.

When B<sub>2</sub> is connected to a positive voltage and B<sub>1</sub> the negative we set the scene for the operation of the unijunction. If we raise the positive voltage of E slowly, nothing happens until we get to a specific voltage. The instant that that threshold voltage is reached the unijunction's resistance will fall dramatically between B<sub>1</sub> and E. This effect is used in the mosquito repeller project. (See "How it Works" in this project).



UNIUNCTION

# Component marking codes . . .

## SEMICONDUCTORS:

Semiconductor devices (transistors, diodes, IC's, etc) come in an enormous variation of shapes and sizes. Despite this, there is a remarkable amount of standardization.

Because a great deal of innovation in semiconductors emanates from the USA their influence in physical component design has been dominant. Whilst the industry co-operates closely in this area, a governing body has co-ordinated this effort. The governing body is called JEDEC. It stands for Joint Electron Device Engineering Council.

Most standard semiconductor packages today have JEDEC designated numbers. For example, the plastic case transistors DS548 and DS558 conform to "TO-92" package size. Many IC's with 14 pins conform to TO-116.

How does this help you? Well it helps you to identify a component if its markings have rubbed off, or in the case of IC's it helps identify which lead is which.

Whilst it may be easy for you to recognise a transistor, it is not always easy to recognise which lead is which. If in doubt consult the manufacturers data sheet for that product.

### Transistors:



### Diodes:

Usually have a band at one end indicating the cathode end.



A typical diode with a band at one end to indicate the cathode (K).



Circuit symbol for a diode.

### IC's:

For the sake of this explanation we will only refer to the IC's used in this book.

These IC's are made in 'Dual-in-Line' packages or "DIP's" in various lengths.

All DIP IC's in this book – indeed as far as we know most DIP IC's made, conform to the lead numbering system shown,

Viewed from the top (always) with the pins pointing away from you.

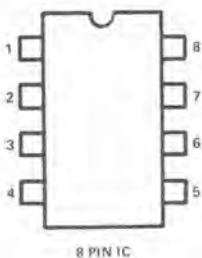

8 PIN IC

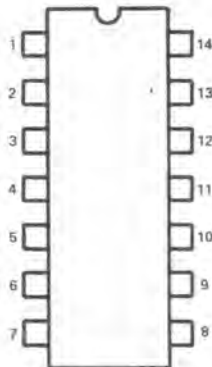

14 PIN IC

Index area. Within this approximate boundary you should find some sort of orientation mark. It is usually a notch in the plastic but it may be a spot of paint or a printed symbol etc.

Top left pin is always No.1 pin. Pin 2 is directly below that and so forth.

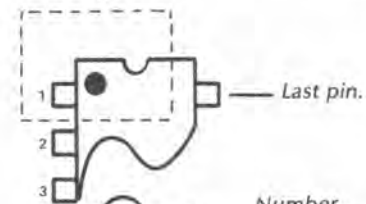

Number sequence rotates in an ANTI-CLOCKWISE direction. Pin in bottom right hand corner is the next number after pin in bottom left hand corner.

General rule for IC's whatever number of pins.

**REMEMBER:** (i) These rules apply only if the IC is viewed from the top.  
(ii) If in doubt, consult the manufacturer for information.

## Resistors:

Resistors are usually so small it is impractical to try and print each one with its value, so they are marked with a code printed on them in bands of different coloured paint. These bands give us the resistor's value.

### The colours and their values:

BLACK	0	BLUE	6
BROWN	1	VIOLET	7
RED	2	GREY	8
ORANGE	3	WHITE	9
YELLOW	4	GOLD *	x0.1
GREEN	5	SILVER *	x0.01

\* RARELY USED

### How to read them:

Start with the band closest to one end or, if it is difficult to work out, the band furthest away from the gold or silver band. Take the resistor shown to the right: lets say that the first band is orange – from the table this means three. If the second band is white, then its value is 9, from the table. And finally if the third band is brown we have a value of 1, so we add one zero to the first two figures: 3, 9 and 0 – or 390 ohms.

The fourth, or tolerance band, is silver: 10%. Therefore, the resistor is 390 ohms, 10% tolerance (or somewhere between 390 -10% and 390 +10%, or 351 and 429 ohms). This is more than adequate for most circuit requirements. Resistors are available which are 'spot on' in value – however, these are not required in most circuits, and are often very, very expensive.

## Capacitors:

Most capacitors will have their value printed on them. However, there are a number of capacitor manufacturers who use the 'IEC' code. This code is a numerical code, but works in a similar way to the resistor colour code: two figures followed by a multiplier. There is often a single letter code showing tolerance.

The code is worked out in picofarads, so you may have to use the appropriate metric multiplier.

A capacitor may have a code '104K'. This decodes as follows – 0.1uF, 10%. The first two figures give us 10, the third figure gives us 0000, and the letter 10%. Therefore, the capacitor is 10 0000pF, 10%. We normally express this as 0.1uF – capacitors with a value below .001uF are expressed in picofarads.

There may be a further figure marked – this would be the voltage rating of the capacitor (the maximum voltage at which you can use that capacitor).

## Metric units and conversions:

Throughout this book and, indeed, most electronics publications, metric multipliers are used to simplify and shorten component values, etc.

For example, capacitance is measured in Farads – but the Farad is a huge unit of measurement, much too large to be of any use in expressing capacitor values. So we use a suitable metric sub-multiple to save a lot of figures. Instead of saying, for example, .000000000001 Farads we say 1 pico Farad (1pF).

We have used only micro Farads (uF) and pico Farads (pF) in this book; however, some publications use the abbreviation nano Farad (nF) so you should get to know these eventually, too.



### What they mean:

- Band one – 1st figure of value
- Band two – 2nd figure of value
- Band three – number of zeros/multiplier
- Band four – tolerance (±%). See below

Tolerance band colours: Red 2%; Gold 5%; Silver 10%; No band 20%.

Note how the bands are closer to one end of the resistor than the other.

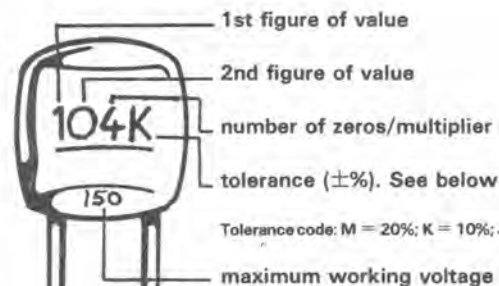
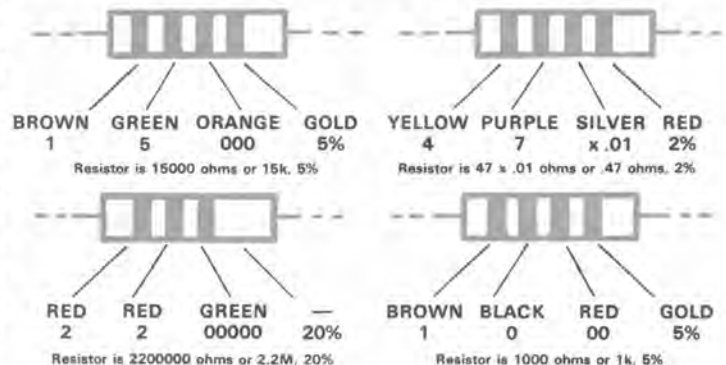

Tolerance code: M = 20%; K = 10%; J = 5%; C = ±0.25pF

Some circuits show capacitor and resistor values as straight figures – e.g. 4.7pF. Others replace the decimal point with the first letter of the sub-multiple (e.g. 4p7 is the same as 4.7pF). Similarly with resistors: 6k8 means the same as 6.8k.

Abbreviation	Means	Multiply unit by	Or
p	pico	.000000000001	10 <sup>-12</sup>
n	nano	.000000001	10 <sup>-9</sup>
u	micro	.000001	10 <sup>-6</sup>
m	milli	.001	10 <sup>-3</sup>
—	UNIT	1	10 <sup>0</sup>
k	kilo	1 000	10 <sup>3</sup>
M	mega	1 000 000	10 <sup>6</sup>

1000 pico units = 1 nano unit  
 1000 micro units = 1 milli unit  
 1000 units = 1 kilo unit

1000 nano units = 1 micro unit  
 1000 milli units = 1 unit  
 1000 kilo units = 1 mega unit

# reading circuit diagrams

At first circuit diagrams will confuse you if you have not already gained some familiarity with them from FUN WAY INTO ELECTRONICS VOL. 1.

It will help you to realise that the circuit symbols are simply the alphabet of another language. We all use several languages, in addition to the normally written and spoken English language. For example: road signs – used by motorists and pedestrians; the Greek alphabet – used in mathematical equations; company logos – designed to communicate a company's function, often without using words; the symbols in public buildings to designate various rooms. We learn to use these signs through familiarity gained by asking what they mean and by using them.

When you are learning the symbols used in electronic circuit diagrams, try and relate the symbol to the actual physical construction of the component it represents. For instance, a capacitor is really two conductive plates separated by an air gap or other dielectric and the symbol shows two flat plates separated by a gap. A variable capacitor has an arrow on one plate, which is curved to show that it can be turned, or an arrow across both plates meaning the same thing.

The wiggly line of the resistor symbol immediately suggests a more difficult path for the flow of electrons i.e., a more resistive path. Again an arrow indicates a variable resistor. Coils and transformers which in reality have coils of wire are shown as coils in the circuit diagram.

Diodes, which pass current in one direction and block it in the other, are represented by a symbol which shows an arrow in one direction and a line blocking flow in the other. Integrated circuits are shown either as a rectangle "block", or much as they look with their polarity and pin numbers clearly indicated.

Using these examples as your guide, check through all of the components comparing the symbol with the diagram and with the actual component in each case. Soon you should be able to look at any circuit diagram and readily name each component.

Once you are able to recognise the symbols and understand what each component does, you are well on the way to understanding circuit diagrams. All that remains is to be able to read how the different components are wired together.

This becomes quite straightforward

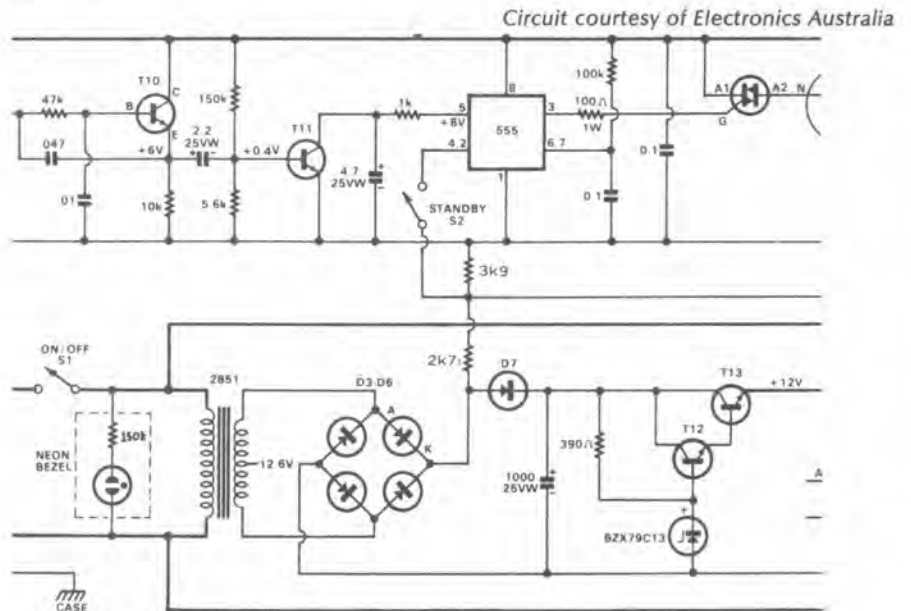

This circuit diagram is typical of those we use in this book. By now, you should be able to recognise many of the circuit elements: resistors, capacitors, diodes, transistors, etc. The strange symbol in the top right hand corner represents a 'triac'; a device used extensively in power control circuitry. The box-shaped symbol near it is for an integrated circuit: in this case, a 555 timer IC (we use this IC in some of our 'Fun Way' projects).

when you know that a small dot at the junction of two or more wires shows that they are joined, while a semicircle or hump indicates one wire passing over another without contacting it.

As indicated in the section on components, some components are polarised – i.e., they have positive and negative symbols marked on them. These components must always be connected into the circuit with the correct polarity, otherwise damage may occur either to the component itself or to other parts of the circuit. If a polarised component is connected the wrong way around, generally the circuit will not work at all.

The symbols shown next to the component section are standard symbols used throughout the world (with minor variations) so even if a circuit appears in a foreign language handbook, you should still be able to interpret it.

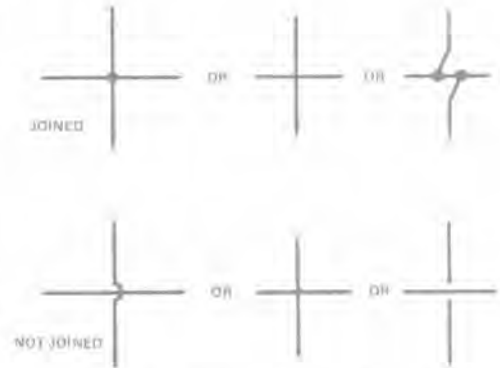

These two groups of drawings show how joins and cross-overs may be shown in circuit diagrams. In Fun Way, we use the first way shown on each line. However, other publications may use the alternatives.

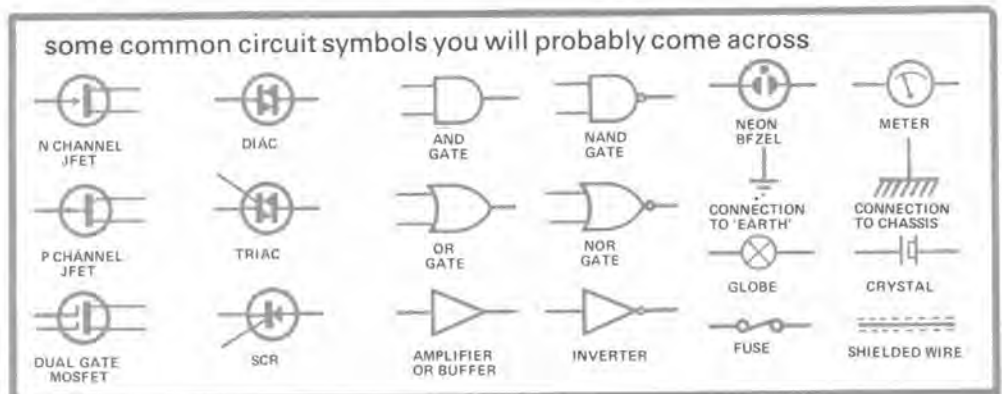

# circuit laws

It is not essential that you learn these laws to build the projects in this book, but they are very simple, and an understanding of them will increase your enjoyment of the subject. You may also use these laws to design your own circuits, find faults, etc, as your knowledge of electronics grows.

## Ohm's Law

The relationship between voltage, current and resistance in a circuit is defined by Ohm's law, which may be simply stated as: 'when a voltage is applied to a resistive circuit the current in Amperes will be proportional to the voltage and inversely proportional to the resistance in Ohms'.

This relationship is represented mathematically by the formula:

$$E = I \times R$$

where E is in volts, I is in amps and R is in ohms.

This can be turned around to look like:

$$I = \frac{E}{R} \quad R = \frac{E}{I}$$

If you find these difficult to remember, you may find the diagram below helpful:



Simply cover the value you are looking for with your fingertip, and the formula you require remains exposed.

### For example:

In a circuit consisting of a 6V battery and a 12 ohm resistor, we wish to find the current passing through the resistor.



Because we want to know 'I', cover it with your fingertip. The formula to find I is then shown as E divided by R. Substituting values, we know E is 6 Volts and R is 12 ohms; therefore the current is 6 divided by 12 = 0.5 Amps.

Suppose we knew the voltage and current (we could measure these with a multimeter) but the resistor value had been rubbed off. Using the same triangle above, we cover R and find the formula R equals E divided by I. Therefore, R equals 6 divided by 0.5 – or 12 ohms. It agrees with the above answer!

Now try one yourself. We know I is 0.5A, and we know the resistor is 12 ohms. But we're not sure about the battery voltage. How do you work it out?

## Power in a circuit

When a current passes through a component, energy is given off in the form of heat. Normally, we associate resistors with this action: that's part of their job. We often need to know how much power is being given off by a resistor – and we find this out by using a formula derived from Ohm's Law. This formula says that power dissipated is equal to the voltage

across the component multiplied by the current through it; or

$$W = E \times I$$

where W is in watts, E is in volts and I is in amps. This formula, too, can be turned around if required:

$$E = \frac{W}{I} \quad \text{or} \quad I = \frac{W}{E}$$

### For example:

In the circuit above, E is 6 volts and I is 0.5 amps. Therefore, the power dissipated would be 6 x 0.5 = 3 watts. We would have to use a resistor capable of dissipating at least 3 watts – we would probably use a 5W type.

## Series and Parallel Circuits

In all circuits, combinations of components are used to achieve various effects. It is often essential to be able to work out the equivalent values of components connected together. To do this, one must be able to work out whether the components are connected in 'series' or 'parallel' – or a combination of both.

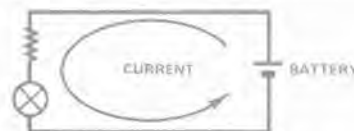

In a series circuit, current flowing from the battery must pass through all the components. Because of this, the current is the same through all components.

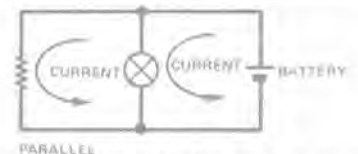

In a parallel circuit, the current can take a number of different paths – so currents are not identical through various 'legs' of the circuit.

## Resistors in series

Resistors in a series circuit are simply added together to find the total resistance. In other words, a 10 ohm, 150 ohm and 1000 ohm resistor connected in series would be the equivalent of a single 1,160 ohm resistor. The formula is:

$$R_T = R_1 + R_2 + R_3 + \dots$$



## Resistors in parallel

Resistors in a parallel circuit are a little more difficult. Here the reciprocals are added together to give the reciprocal of the total. The formula to use is:

$$\frac{1}{R_T} = \frac{1}{R_1} + \frac{1}{R_2} + \frac{1}{R_3} + \dots$$

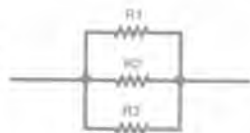

## Capacitors in parallel

Capacitors behave exactly the opposite to resistors: when capacitors are in **parallel**, you add them:

$$C_T = C_1 + C_2 + C_3 + \dots$$

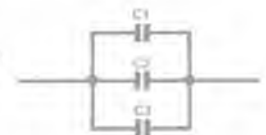

## Capacitors in series

Capacitors in series, on the other hand, are similar to resistors in parallel: you add the reciprocals:

$$\frac{1}{C_T} = \frac{1}{C_1} + \frac{1}{C_2} + \frac{1}{C_3} + \dots$$



**Two resistors in parallel or capacitors in series:** A much simpler formula can be used if there are only two resistors in parallel or capacitors in series. It is: (For capacitors simply replace R with C).

$$R_T = \frac{R_1 \times R_2}{R_1 + R_2}$$

# Assembly hints and tips

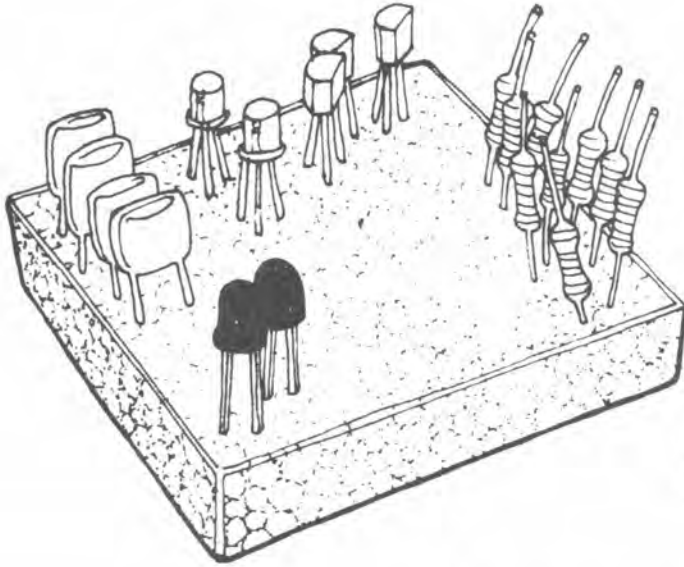

Figure 1: A block of styrene foam is the ideal way of holding components prior to insertion in the PC board.

As you gain experience in assembling electronic projects you will learn the best way to handle the components and how to achieve the best results most efficiently.

To save you a lot of trial and error and perhaps a few disappointments, we have set down a few hints that have been proven over the years to make assembly easier.

1. In all cases, the first thing to do when constructing a project from a kit is to check that all parts have been supplied. Do this by ticking them off against the parts list shown with each project in this book.
2. Collect all the components in a dish or plate, or stick them into a block of styrene foam as shown in figure 1. This prevents them rolling off the table and getting lost or damaged.
3. Start construction by mounting resistors and capacitors first, taking care that they are properly 'dressed' or positioned to give your job a professional appearance. Good dress simply means lining the components up so that wherever possible the codes are in the same direction and read from left to right say with the PCB facing towards you. When the PCB is turned clockwise through 90° all other components (normally running away from you) should again read left to right as the

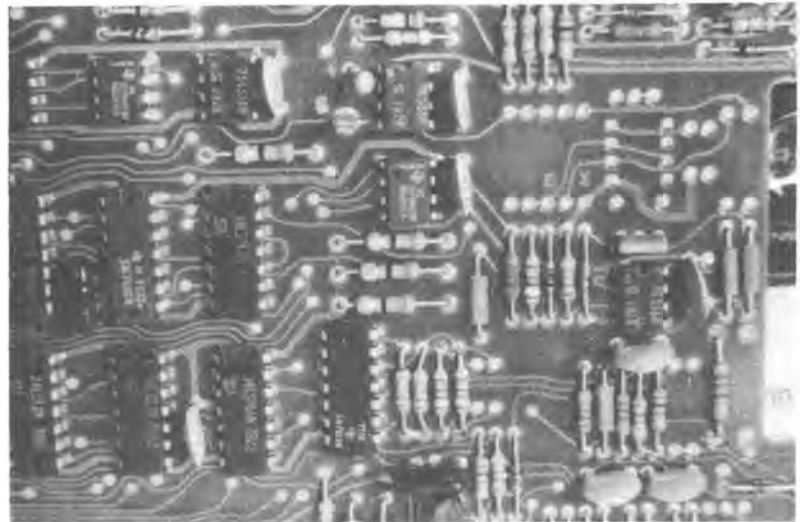

Figure 2: This illustration of a computer board shows the strict method of 'dress' used - it enables rapid identification of circuit sections and components.

- component layout suggests. Capacitors should read from the same direction as the resistors. And where components lay side by side, their codings should be oriented where they can be seen. Those components that are polarised must obviously be installed as indicated on the overlay or component layout diagram. Components should be straight and parallel. See figure 2.
4. To achieve a professional result, care should be taken when installing components on to the PCB. See figure 3 for the correct installation of a resistor. First measure the hole spacing

and bend the component leads as shown with your long nose pliers. Then insert them through the top of the board and pull them through the copper side until the component rests flat against the top of the board. Bend the leads to about 45° to hold the components on to the board, solder them and clip them off neatly against the solder. This allows them to be easily removed if necessary later on.

**Note:** Don't bend the component leads too much as they may suffer metal fatigue and break off. Also, don't bend the leads too close to

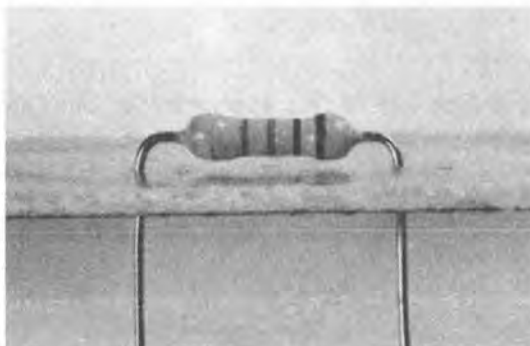

Figure 3: This resistor is partially inserted – the body will finally touch the top of the PC board and the leads on the copper side bent to retain the resistor in position prior to soldering.

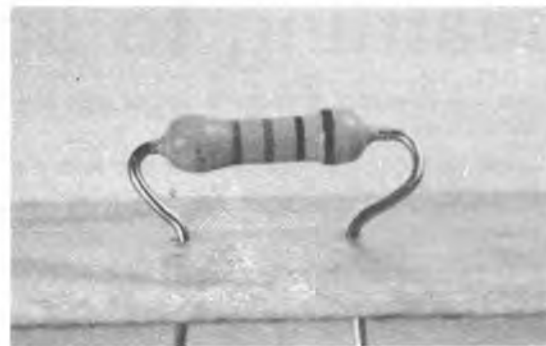

Figure 4: This is an example of a poorly inserted resistor. As the body of the resistor is longer than the hole spacing it would have been advisable to insert as shown in Figure 5.



Figure 5: The correct method of upright installation when the hole spacing is restricted. Note in particular how the lead has been bent.



Figure 6: This is an example of an axial lead capacitor mounted in the upright position. When mounting electrolytic capacitors special care must be taken to ensure correct polarity.

- the component itself – especially transistor leads.
5. Be careful when cutting off a component's leads to make it fit better that you don't cut off the way the component's polarity is marked. This applies especially to Light Emitting Diodes (LEDs) – the negative (cathode or 'K') lead is normally shorter than the anode lead.
  6. Offcuts of component leads may be used as wire links, so it is a good idea to save them.
  7. It is not absolutely essential that components have the exact value shown in the circuit diagram. Both circuits and components are designed with certain tolerances and will probably work satisfactorily provided components are "close enough". This applies even to transistors, as there are often several equivalent substitutes for any one transistor.
  8. Before you connect your battery, double check all your components and wiring. Ensure that you have the correct components in the correct place with the right polarity, and that there are no other obvious faults.
  9. You'll find it useful to start a spare parts box, to store bits and pieces that may come in handy when building up circuits in the future. You'll need to be fairly ruthless about throwing junk out though, or you could finish up with piles of useless bits and pieces.
  10. When soldering to terminals, such as on speakers, the joint should be made mechanically robust first, so that the strain of the joint is taken by the wire itself, not by the solder. The solder merely forms a good electrical bond between the wire and the terminal.

# learning to solder

Learning to solder correctly from the start will save you many hours of frustrating fault finding, as poor solder joints are the main reason that projects do not work.

Good soldering is the hallmark of the skilled electronics hobbyist and gives a sense of satisfaction in itself as well as going a long way towards ensuring that your project works correctly the first time you try it.

Good soldering requires the right iron properly prepared, the right solder, a correctly prepared joint and practice, practice, practice.



Figure 1. The most important tool for the electronic hobbyist is the soldering iron. This illustration shows a typical hobbyist iron and the correct way to hold it.



Figure 1a  
It is important to keep your soldering iron clean at all times. This illustration shows a dirty, corroded bit that would certainly not aid you in obtaining a clean, secure joint.

## The Iron

An electric soldering iron of 10-30 watts rating with a 1.5 - 4mm chisel bit is ideal for the projects in this book. (See Fig.1). Such an iron should give years of service if reasonable regular maintenance is performed.

As most modern irons have plated tips it is not necessary (or advisable) to file the copper tip. If your iron has a plated tip simply switch the iron on and let it heat up. Once it has reached its operating temperature simply wipe the tip on a piece of damp cloth. This should expose a shiny surface. Apply a small amount of solder to this tip. Your iron is now ready for service.

Keep the tip clean at all times by periodically wiping it on a damp cloth or soldering sponge.

## The Solder

The best solder for general electronics work is 60/40 solder (see 'components'). We recommend that you use a 60/40 solder that is pre-fluxed i.e. it has a small thread of flux running down the centre of the solder wire.

**DO NOT** use acid core solder or bar solder with Muriatic acid or 'Killed Spirits'. These fluxes and solders are commonly used by plumbers and tradesmen. Because of the corrosive nature of such fluxes they are not suitable for delicate electronic work.

## Preparation

They say that there are three rules to be observed when soldering. They are: (i) **Cleanliness**; (ii) **Cleanliness** and (iii) **Cleanliness**.

Specifically though all parts of the joint to be soldered must be clean and free from tarnish, insulation and lacquers. If necessary use sandpaper or a fine file to clean the parts to be soldered. Most of your soldering will be components to Printed Circuit Boards (PCB's) or of wires to tags or lugs and these should be treated as follows:



## Component placement

Ensure that the PCB lands are clean and position the components as shown in figure 2 so that the resistors and capacitors are flush with the board and values are easily read (except for electrolytic capacitors where polarity must be observed). Splay the leads as shown to hold the components in position until soldered.

Mount transistors proud of the board while Integrated Circuits (IC's) are pushed in until the shoulders of the pins are flush with the top of the PCB. (See figure 3). When you have several components mounted you can turn the PCB over and solder the leads as described below. When the joints have cooled and after checking that you have the components correctly positioned and soldered, snip off the excess lead neatly with your side cutters.

## Soldering

Holding the heated iron as you would a pencil (see figure 1), place the tinned tip on the junction of the lead and the PCB track. Allow about one second for pre-heating and then apply the solder to the point where the bit contacts the lead and the PCB track. When just enough solder has flowed to cover the joint, slowly remove the solder and the iron together in a smooth action to leave a nice clean joint. (See figures 4, 5 and 6).

The soldering of components to a PCB, tag strip or tracked board etc, will become much easier as you gain experience and confidence. For problem joints turn to the next page where the causes and the remedies are explained.

**Note:** When soldering semiconductor devices and other heat sensitive components it is a good idea to hold the lead with a pair of pliers or a heatsink clamp (see figure 7), to prevent damage from overheating. (This will become less necessary once you can solder quickly and reliably). For each of the projects in this book we recommend the use of a heatsink clamp when soldering heat sensitive components.

## Wiring to a tag

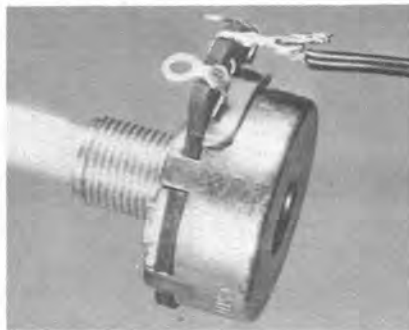

Ensure that the wire is clean and free of insulation and that the tag or lug is clean and untarnished. If the wire is stranded it must be twisted and tinned after stripping. Thread the wire through the tag until the insulation is up to, but not quite

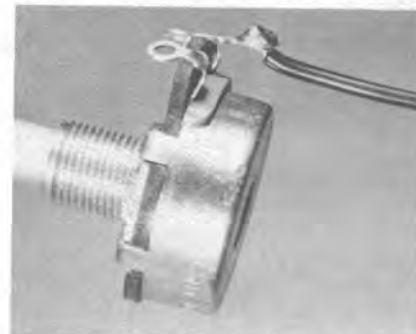

touching it and bend the excess around to make a good tight mechanical connection. Snip off the excess and the termination is now ready for soldering as described on this page.

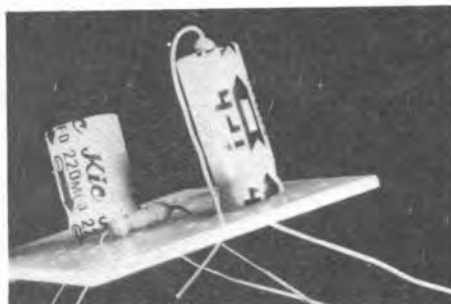

Figure 2

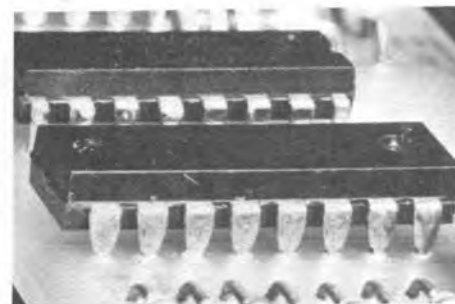

Figure 3



Figure 4

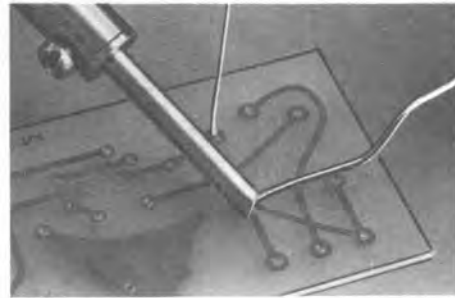

Figure 5

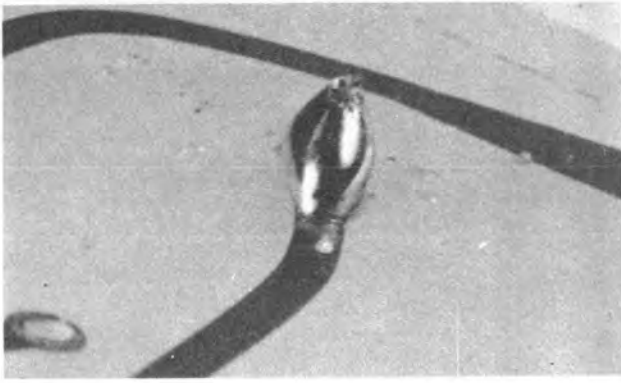

Figure 6



Figure 7

# Common faults, causes and remedies



## Solder forms a ball.

**Cause:** not enough heat.

**Remedy:** re-heat and apply a touch more solder.

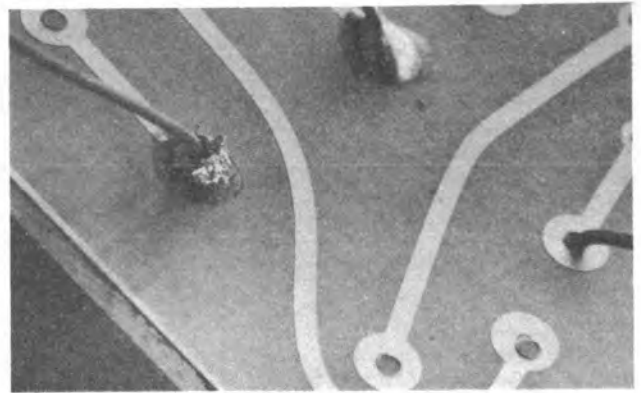

## Joint looks cracked and frosty or crystalline.

**Cause:** too much heat or lead has moved.

**Remedy:** re-heat and apply a touch more solder.

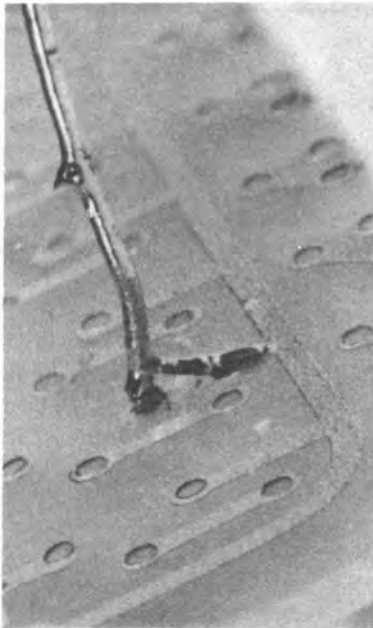

## PCB track dark and lifting and solder not taking.

**Cause:** too much heat and possibly a dirty track or lead.

**Remedy:** allow to cool, clean, carefully re-heat and apply more solder.

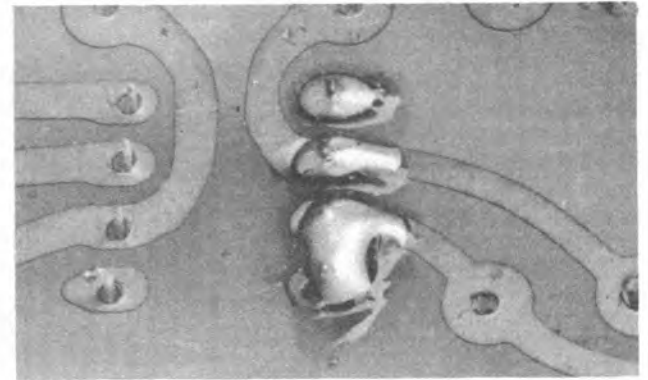

## Solder is bridging or spiking between two lands or leads.

**Cause:** too much solder.

**Remedy:** Carefully re-heat and apply a touch more solder to facilitate removal of excess solder with iron.

These are the main problems you will encounter and the best remedy of all is prevention! Obtain an old PCB (superceded ones are extremely cheap) – and PRACTICE! PRACTICE! PRACTICE!



## Solder will not take to lead.

**Cause:** lead is dirty.

**Remedy:** remove heat, allow to cool and clean lead before resoldering.

# controlling other circuits with relays . . .

A relay has several basic parameters which determine its usefulness in a circuit.

- (1) Its coil resistance – this determines the range of voltage over which the relay will reliably operate.
- (2) Its contact rating – which determines the amount of current and voltage the contacts can safely switch
- (3) The number and type of contacts – some relays have just a single switching action which may be single throw or double throw (see 'switches' in the components section). Other relays may have a number of poles, with single or double throw action or even combinations of both. In most instances, the individual contacts of the relay are all insulated from one another, and can be used to switch different circuits without interfering with one another.

If, for example you wish to switch two devices with one relay, you can do this with a 'double pole' relay (one having two sets of contacts). Relays are commonly available with up to four sets of contacts; special purpose relays have many times this number.

The relay we use in the 'fun way' projects is a very simple type, chosen mainly because of its size: it fits nicely onto the printed circuit boards. However, it has only one single pole, double throw contact set (also known as a changeover contact).

Let's say you want either more contacts or larger current carrying capacity, to use with one of the projects in this book. What do you do?

Of course, it would be possible to substitute a relay with the right coil resistance for the one on the PCB. All

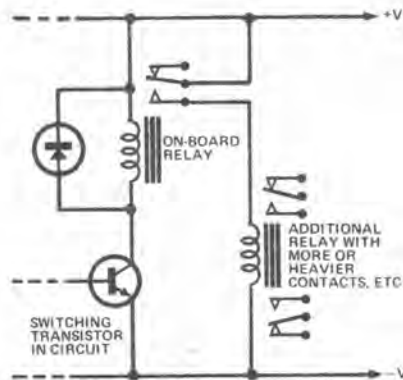

Figure 1

you need is one with a coil resistance of around 180 to 220 ohms, designed to 'pull in' at voltages from around 6 to 14.

Such relays are fairly common. However, size becomes a problem: the PCB's have been designed to fit only the small relay, any other type would have to be mounted off the board with leads connecting it to the correct pads.

The easiest way for the beginner to solve this problem is to use one relay to switch another: leave the one on the board as designed, and use its contacts to switch the second relay coil. This has a further advantage: if you want to 'invert' the operation of the circuit, you can use the 'normally closed' contacts and have the second relay operate in reverse to the way it would otherwise have done.

Figure 1 shows how to wire a second relay 'in tandem' with the one on the PCB. Because the second relay is being switched by another relay (not a transistor), it doesn't need the 'spike clamping' diode across it which you

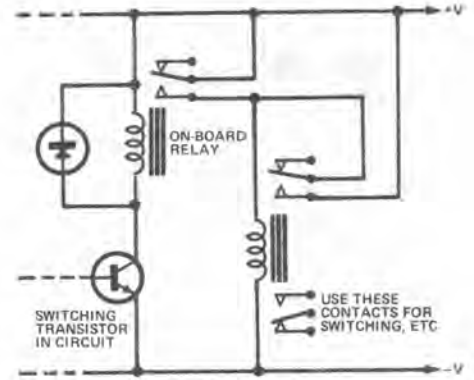

Figure 2

would normally use on a relay.

You can use any relay which will pull in with the voltage available from the battery or plug-pack adaptor (if you are using one). Just remember that a relay which pulls in reliably with a fresh battery may not be quite so keen when the battery gets a little flat!

You can use a relay with any number of contacts to suit the application. Ensure that you don't get solder dags across the contacts, as in some relays they are very close together.

**Making a relay 'latch'.** (See figure 2).

If a multi-contact relay is used, it is easy to make the relay latch on – that is, when it pulls in, it stays in regardless of what happens in the rest of the circuit. The only way to make the relay drop out again is to disconnect power.

This is done by using one set of contacts to bypass the switching transistor, thus keeping current flowing through the coil even though the transistor stops conducting. Once again, a diode is not necessary.

## about the project kits . . .

Each of the projects in this book has an individual kit of parts made up for it: these are available from any Dick Smith store or re-seller. The catalogue number of the kit is given at the bottom of each component list.

To keep the cost of the kits to a minimum (and allow you as much flexibility as possible with your project) the kit contains only those components described in the main list.

In other words, the kits do not include Zippy boxes, batteries, buzzers, sockets, Morse keys, or with the exception of a couple of kits, any switches. Nor do they include any items of hardware, etc, which might be mentioned in 'what to do next'

They do, however, include the printed circuit board, battery snap, speaker/earphone (where applicable) plus all components required to make the basic project actually work.

Where potentiometers are specified, the kit includes a pre-set trimmer type (even though the drawing might show a conventional shaft type). Once again, this is to keep the kit cost down.

Whether you replace the pre-set with a normal potentiometer, place the kit in a Zippy box, add on/off switches, external sockets, etc, is left completely up to you. Of course, should you decide to 'dress up' your project, all the components are readily available types, and are available from your

nearest Dick Smith Electronics store or re-seller.

The printed labels in the back of the book suit the commonly available Zippy boxes.

Please note that the kits do not include instructions: after all, you're reading this book, and all the instructions are in it!

The contents of this book are copyright, and may not be photocopied or re-printed for any purpose without the written permission of the publisher.

# project number one

## A Multi-Purpose Flashing LED

This is a versatile project: it can be used as a simple warning indicator – outside a darkroom door, for example. Or it can warn a thief that your car is fitted with a burglar alarm – even if it isn't!

Or you can turn this into the very latest in electronic jewellery. The board has been designed to wear as a brooch or pendant: why pay \$50 or more when you can make your own, the Fun Way?



## you will need these components

### Resistors:

- R1 330 ohms
- R2 47k ohms
- R3 47k ohms
- R4 560 ohms

### Capacitors:

- C1 2.2uF 16VW tantalum electrolytic
- C2 10uF 16VW tantalum electrolytic

### Semiconductor Devices:

- LED1 light emitting diode
- TR1 NPN transistor DS548 or similar
- TR2 NPN transistor DS548 or similar

### Miscellaneous:

- Battery snap, solder, hook-up wire.

You will also require a 9 volt transistor battery (not normally supplied with a kit) or some other 9 volt DC power supply.

A suitable mounting board or printed circuit board of correct design (DSFW2 K-2621 Flasher Kit contains the correct PCB).

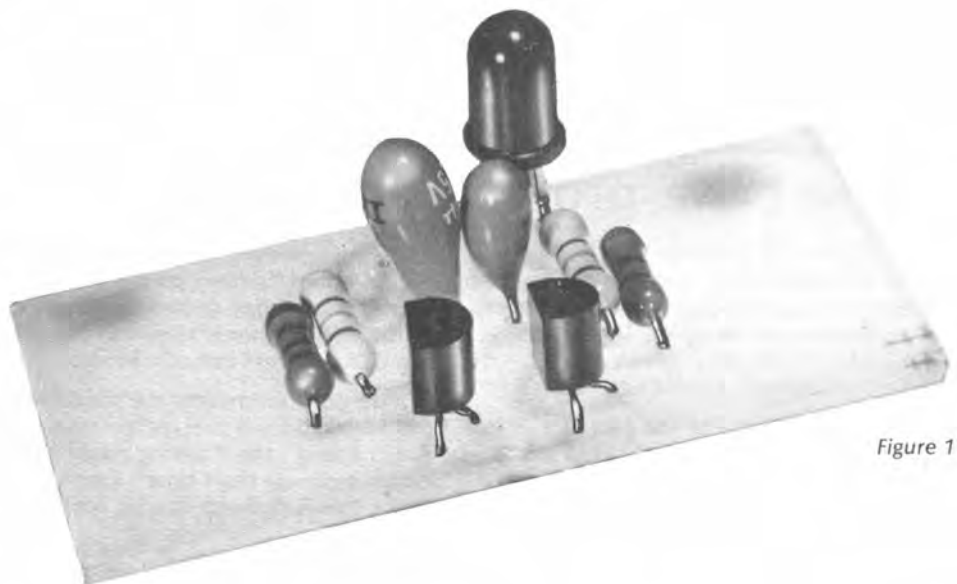

Figure 1

## how it works

When power is applied, the capacitors C1 and C2 start to charge to the supply voltage via the base/emitter junctions of TR1 and TR2. This charging current tries to turn both the transistors on. But both cannot turn on at the same time, as we will see in a moment. So a 'race' occurs: by a combination of component tolerances, one of the two transistors will turn on first.

By the time the transistor has turned on (let's assume it to be TR1) the capacitors have reached a reasonable state of charge. They could have quite a few volts across them. So the positive end of the capacitors would be a few volts positive with respect to the negative ends.

As you can see, the positive ends of the capacitors are connected to the transistor collectors, with their negative ends to the opposite transistor's base.

When TR1 turns on, its collector voltage drops to a low level – probably around 1 volt. But wait: the capacitor connected to this point has a potential of 6 volts. What happens here?

Because the capacitor has resistance in series, it cannot discharge immediately. So whatever voltage the positive end becomes, the negative end must go another 6 volts below that again! If the collector of TR1 goes to 1 volt, the negative end of C1 must go to around **minus 5 volts!**

As the negative end of C1 is connected to the base of TR2, this means that TR2 is well and truly turned off, and it remains in this state while C1 discharges through R1, the LED and R2.

Eventually C1 discharges, and TR2 can then turn on via R2. As soon as this happens, C2's negative end drops down to minus 5 volts, turning off TR1. C2 eventually discharges, allowing TR1 to turn back on again, turning off TR2...

The cycle repeats as long as power is connected.

As there is a LED in series with TR1, every time TR1 turns on, the current flowing through it must also flow through the LED. Thus it flashes, giving us one flash for each 'cycle'.

A second LED can be connected in series with TR2's collector (see 'what to do next'), giving two flashes per cycle.

The speed at which all this occurs is governed by the value of resistors R2 and R3, and capacitors C1 & C2. Varying any or all of these components will vary the circuit speed.

## putting it together

- (1) If you have purchased a kit (Dick Smith Cat K-2621 or similar), check the components against the parts list to make sure they are all there, and are the correct types and values.
- (2) If you have not purchased a kit you will need to obtain the components listed and either make a printed circuit board from the pattern overleaf, or use a perforated or tracked board.
- (3) Mount the components as shown in the component position drawing. Place and solder the resistors and capacitors first, taking care to ensure that the capacitors are correctly polarised. Check that all components are 'dressed' (or positioned neatly) before soldering them in place.
- (4) Place the LED in the correct way around or it will not flash. The anode, the longer of the two legs, goes towards the outer edge of the PCB: that is, to the same track as connects the positive battery lead. The LED can be soldered in where shown in the position drawing, or in the opposite side as shown in the photograph. Which ever side is chosen, a link is soldered in the opposite position.
- (5) Position and solder TR1 and TR2. If you are unsure about your soldering ability yet, use a heatsink clamp on the transistor leads to prevent overheating.
- (6) Solder in the battery wires, again taking care with polarity. Not much good getting everything else right if the battery is reversed! The positive (red) lead goes to the end of the pcb with the LED on it; the negative (black) lead goes to the end with the transistors on it.
- (7) This printed circuit board has been designed to accommodate two LEDs, but at the moment we need only one. Hence the link we mentioned before: this can be made from a short length of lead 'cropped' (or cut) from another component.
- (8) Go over the board, checking all components once again, your battery connections, etc. If you're satisfied everything is correct, connect the battery and the LED should start to flash immediately. If it doesn't, disconnect the battery, and re-check everything component, soldered joint, and wire. (Maybe your battery is flat?)

Now read on to 'What to do next'

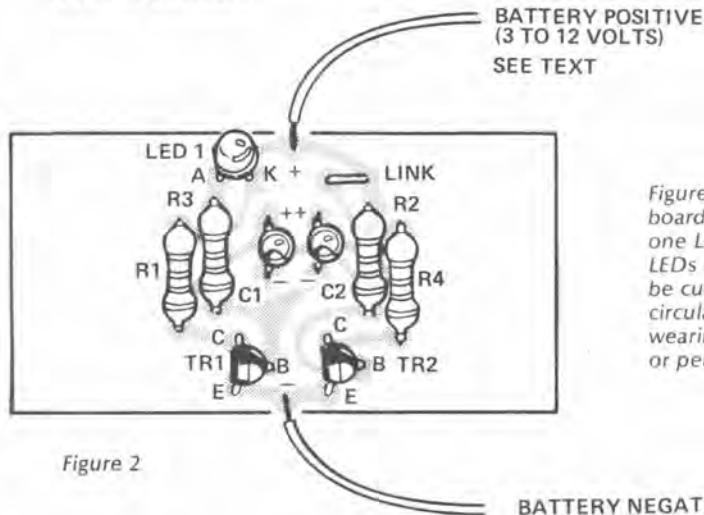

Figure 2

Figure 2: The printed circuit board can be made with one LED, as shown, or twin LEDs (see text). It can also be cut out to leave a circular shaped board, for wearing as a brooch, badge or pendant.

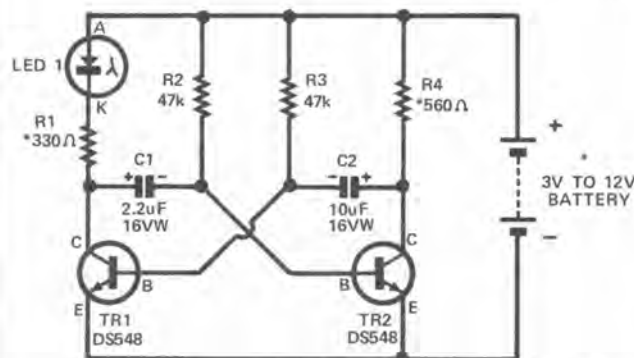

Figure 3

Figure 3: the circuit is very simple: just watch the polarity of components: over half of them are polarised! It will operate from a very wide voltage range.

\* SEE TEXT

# what to do next

One use for this type of circuit is as an alarm indicator in a car. You've probably seen those very expensive car alarms which have a flashing light to warn thieves away. This flashing LED can be used for exactly the same purpose; and you don't even have to have an alarm! (Of course, if you were really clever, you'd combine this project and the Car Alarm elsewhere in this book).

Because this circuit is designed to operate over a wide voltage range, no circuit modifications are needed for 12 volt operation. Just wire the positive lead to the car battery positive (or some other convenient 12 volt point), and the negative to the car chassis (assuming a negative earth vehicle). Unless your car battery is pretty sick, it won't hurt to leave the LED flashing all the time.

## Darkroom warning indicator

This circuit makes a great little warning for darkrooms, etc. If the LED is flashing, it means 'stay out!' Because it might be inconvenient to change batteries all the time, you may wish to run the circuit from a 'plug pack' battery eliminator, plugged into a power point. Figure 5 shows full connection details.

We have shown a basic 'one LED' flasher; however, the pcb has been designed to operate with one or two LEDs. If you wish to add a second LED, simply connect it in place of the link, with the anode (the longer lead) going to the track connecting to the positive supply. Why not connect a green LED in the other side, and have alternate flashing red and green LEDs?

If you do connect a second LED, the 560 ohm resistor should be reduced to the same value as in series with LED 1, for roughly equal brightness. We have shown a 330 ohm resistor in series, which is fine for 9 or 12 volt operation. If you want to operate from a lower supply voltage (see next page) you might want to put in a lower value resistor for sufficient LED brightness. Values as low as 100 ohms should be satisfactory; remember, however, that the lower the resistor, the heavier the battery drain.

Other modifications you can make to your flasher include the altering of the LED/LEDs on and off times. With the capacitors shown, the on time is very much shorter than the off time. If you make these capacitors equal, the

on/off times of the LEDs will be equal. (Watch the capacitor polarity!)

If you want to use the Flasher as an alarm device, we imagine you will want to protect it in a box. The PCB supplied with the kit has been designed to fit into the smallest slotted Zippy box (Dick Smith Cat. H-2755) with plenty of room for the battery.

If you do use this box, we would assume you will also want to fit an on/off switch. Once again, figure 5 shows the details.

A printed circuit pattern has been given for this project, larger than the pcb supplied with the kit. This is for those who want to make electronic jewellery (see next page). The extra size is to allow room behind the main PCB for batteries. The small pcb is not big enough for this.

On the next page, a pattern is shown for the pcb's which hold the batteries in place. These can be copied along with the pattern on this page and etched in the normal way. (See 'making printed circuit boards').

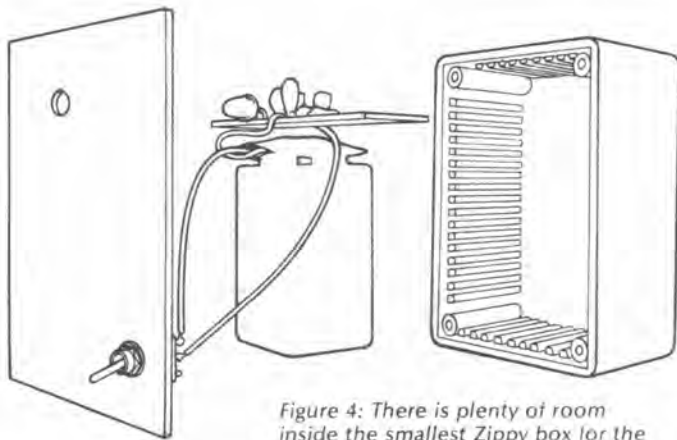

Figure 4: There is plenty of room inside the smallest Zippy box for the PCB. A hole is drilled in the front panel for the LED to poke through.



Figure 6: An over-size version of the LED flasher board for electronic jewellery. Cut the circle shape with a fretsaw, and finish off with a file.

Figure 5a: Basic 'battery snap' wiring without switch. The black lead in all cases is negative.



Figure 5b: Adding an on/off switch. The red lead, or positive, is broken by the switch. Note the centre and one of the outside switch terminals are used.

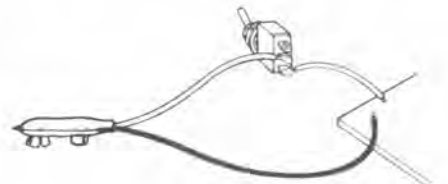

Figure 5c: A 3.5mm socket in place of the switch. The socket automatically cuts off the battery if wired in the way shown.

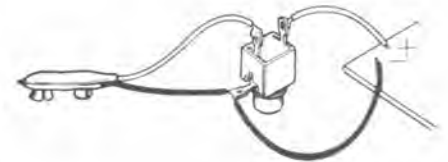

Figure 5d: The battery snap with both an external power socket and on/off switch. The switch interrupts either battery or plug-pack.

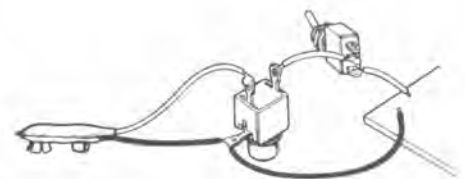

Figure 5: These diagrams show how to add an on/off switch and socket for a plug-pack eliminator to your projects. The same wiring can be used for any project in this book.

# making electronic jewellery

You may have noticed that all the tracks on the printed circuit board are crowded into a small circle in the middle of the board. Normally, this would be taboo: bare pcb should be avoided. Obviously, there is a reason for this!

We have designed the board this way so the circle in the centre can be cut out (with a fine hacksaw and file) allowing the PCB to be used as a brooch or badge. Electronic jewellery is all the rage overseas, and is now being seen in Australia. But the prices have been very high: here is the Fun Way to make your own: at a fraction of the cost!

There are a number of ways you can assemble and wear the PCB. Perhaps the easiest way is to connect fine wires and hide the battery in your pocket or behind your collar. The badge itself can be held on by a tab of double-sided adhesive tape (available from most newsagents & stationers), or a normal pin clasp glued to the back of the board (with 'Araldite' or 'Superglue').

Another suggestion is to mount the brooch on a gold chain, and use the chain itself to carry power down to the board. Obviously, the two halves of the chain would have to be insulated from each other. Another idea we've seen is to have the pcb worn behind a jumper or teeshirt, with the LEDs poked through fine holes between the strands of fabric. This idea looks really neat if the jumper or teeshirt has a design or pattern on it which can be

worked in with the LEDs!

However, the most logical idea as far as convenience goes is to actually mount the batteries on the back of the PCB itself: small silver oxide or mercury batteries are used (the type used in watches). Our drawing and photos below should give you a good idea of how to make up your own brooch or badge.

Once you've made up your PCB, you must decide whether you're going to leave it as is, or just have the LEDs showing. The second method certainly protects the components, but is much more involved. It normally involves a process called 'potting'.

All of the components are set in a clear or translucent liquid which turns hard after a time. Normally a mould is used to form a desired shape, when the mould is removed, the potting compound has taken the shape of the mould.

If the potting compound sets clear all the components can be seen inside. (It normally sets as clear as glass!) Other compounds set with a 'haze', so all that can be seen coming from them is the glow of the LEDs. Sometimes the whole board seems to glow, if the LEDs are set far enough down. The compound is not conductive, so once it is set there are no problems with short circuits.

Potting compound is available from most hobby shops: explain what you want to do and you should get the right material. For a mould, various things

can be used: bottle tops, paper cups, etc – or you can even make your own mould from plaster of paris if you want to achieve some unusual shape.

When potting, you must be careful that the potting material does not 'ooze' down into the battery 'compartment' and stop conduction between the battery and the PCB. Another thing that can stop good contact is corrosion of the copper: as you can probably see from our photos, we coated both battery boards with solder to prevent the copper from tarnishing.

An opposite problem to above is that of unwanted connections – or short circuits between components of the battery holders. The screw head can short onto, or between, the tracks of the flasher PCB itself; we covered the head of the screw with insulation tape before assembly. The nut on the back battery pcb is not soldered to the copper; it is glued to blank board with 'superglue' or 'Araldite'; again to prevent short circuits occurring.

In our simple flasher, we didn't fit an on/off switch: rather, we used the negative lead from the batteries to connect with a small hook soldered to the negative connection point on the main PCB. There are other ideas you could try, of course: for example, a pin clasp glued to the back of the rear PCB which, when closed, completes the circuit.

We have barely scratched the surface of this exciting subject: the limit is your own imagination!

*This is one way to make a brooch or badge with its own battery supply: glue the supply on the back!*

*The batteries are 'sandwiched' between two circular pcb's. These have a slot cut into them (see the pattern below) so that when they are assembled each side of the batteries (with the copper inwards) they connect the batteries in series, giving a 4.5V supply.*

*It is important that the slots are oriented correctly to each other: if you had X-ray eyes and could look through the assembly, the slots would form a 'Y' pattern.*

*If you assemble the pcb's EXACTLY as shown in the exploded view at right, and orient the battery polarities as shown, you shouldn't have any problems.*

*The supply assembly can be glued to the back of the flasher pcb – or it can be held on by the wire connecting the positive supply to the flasher.*

*The supply is turned on and off by screwing and unscrewing the rear-most pcb so that contact is made or broken with the batteries.*

*This is just one idea: of course, there are many other ways to go. For other ideas, why not have a look at some electronic brooches in a modern jewellery shop. See how their brooches are made – and copy them!*

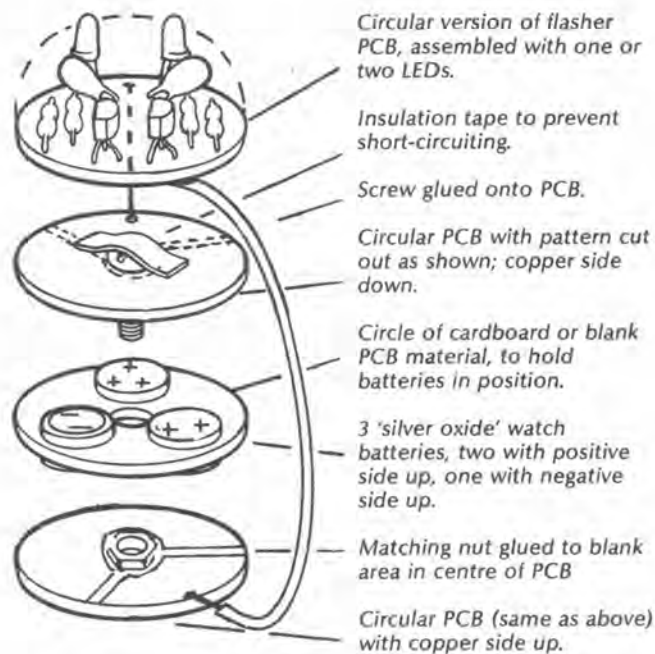

# project number two

## Ding Dong Doorbell



Good doorbells are getting pretty expensive these days . . . especially the types that give a pleasant two tone 'ding-dong'. Here's the 'Fun Way' solution: build your own at a fraction of the cost!

This simple project will really convince everyone that you're a genius at this electronics business: imagine how proud you'll feel when you tell your visitors 'I built it myself!'



you will need  
these components

### Resistors:

- R1 68k ohms
- R2 68k ohms
- R3 68k ohms
- R4 10k ohms
- R5 15 ohms

### Capacitors:

- C1 .01uF polyester (greencap)
- C2 10uF 16V RB electrolytic
- C3 47uF 16V RB electrolytic

### Semiconductor Devices:

- D1 1N4002 diode
- D2 1N4002 diode
- IC1 555 timer integrated circuit

### Miscellaneous:

- 8 ohm loudspeaker
- Battery snap, solder hook-up wire

You will also require a 9 volt transistor battery (not normally supplied with a kit) or some other 9 volt DC power supply.

A suitable mounting board or printed circuit board of correct design (DSFW2 K-2622 Electronic Doorbell Kit contains the right PCB).

If you intend using a push button to operate the doorbell you will need to obtain this separately. DSE Cat. S-1102 momentary contact press 'ON' button is ideal.

See the **What to do next** section for other components required for different applications.

This project is an ideal introduction to electronics: economical and easy to build, but very useful around the home or office.

You press the push button, and a pleasant 'ding' sound greets you until you release the button. Then the note changes to the familiar 'dong' sound, and dies away.

Of course, its uses are not confined to a doorbell: this little circuit can be used wherever an audible warning is required: use it in conjunction with many of the projects in this book. Just imagine the possibilities . . .



Figure 1



# how it works

This is the first circuit in this book to use an integrated circuit. IC's are very useful devices because they contain the equivalent of dozens – sometimes hundreds – of components, already wired together!

We use the 555 timer IC, which is a device for generating accurate time delays. By selecting a few components and the connections we make to the IC, we can make it repeat a time delay over and over again – or oscillate.

In our circuit, when the button is pressed, C1 charges via D1, R2, & R3. (Note at this time R1 is effectively 'short circuited' by D1 and does not play any part). As C1 charges, the voltage across it increases. Eventually, the 'trigger voltage' of the IC is reached, causing the IC to 'fire'. This causes a pulse of current through the speaker, resulting in a 'click'.

Once the IC fires, C1 quickly discharges. The IC then turns off, allowing C1 to start charging again, repeating the process over and over.

This happens many, many times each second (the number of times is determined by R2, R3 & C1) – and each time it happens, a click comes from the speaker. The clicks tend to run into one another, resulting in a single tone.

At the same time all this is happening, C2 is charged via D2, waiting to play its part.

This happens when the push button is released. R1 is once again restored to the circuit, resulting in a longer charging time for C1. Hence there is a lower tone from the speaker.

C2 starts to discharge via the IC and R4. As it discharges, the voltage drops – and quite soon the voltage drops below the IC's 'reset voltage'; the voltage required to keep the IC oscillating.

So the tone coming from the speaker ceases, and the circuit is ready for the next pressing of the push button.

Different tones may be obtained by changing the values of R2, R3 and C1 (these effect both tones), and R1 (effecting the last tone only). The duration of the first (higher) tone is governed solely by the length of time the button is held pressed.

The length of the second tone (the lower one) can be changed if you wish: C2 and R4 control this. Increasing either or both of these will result in a longer tone; decreasing them will shorten it.

# putting it together

- (1) If you have purchased a kit (Dick Smith Cat. K-2622 or similar), check off the components against the above list to make sure they are all there and are the correct types and values.
- (2) If you have not purchased a kit you will need to obtain the components listed and either make a printed circuit board using the component position drawing as a guide, or use a perforated or tracked board.
- (3) Mount the components as shown in the component position drawing. Place and solder the resistors and capacitors first, taking extra care to mount C2 and C3, the electrolytic capacitors, the right way around as they are polarised. Check that all components are positioned neatly and properly 'dressed' before soldering them in.
- (4) Taking care to ensure that you have them the right way around, mount D1 and D2 – the silver band on these diodes indicates the cathode end (K) – and solder them in.
- (5) Now you are ready to mount IC1 the 555 timer integrated circuit. If you have ever used an IC you

will know that they are not really difficult to mount. If this is your first just follow these steps carefully and you will see how easy it is. . . insert the integrated circuit into the holes on the PCB until the shoulders on the pins prevent it from going any further; make sure it is the right way around, by noting that pin 1 (in this case the one marked with the circle indented into the top of the IC) connects to the negative track where it joins C1, C2 and R4; then carefully solder each of the pins to the pads, making sure that you don't run solder between the pads. While it is important not to overheat the IC, it is just as important that enough heat is applied to properly solder the joint. (See **How to Solder**). You may prefer to use an IC socket or Molex pins until you have more confidence in your soldering. Inspect the connections to make sure you've soldered them all without shorting any of the pads and that's it. Not so hard after all!

- (6) Connect the speaker to the correct pads on the board and the terminal on the back of the speaker. Refer to **Project**

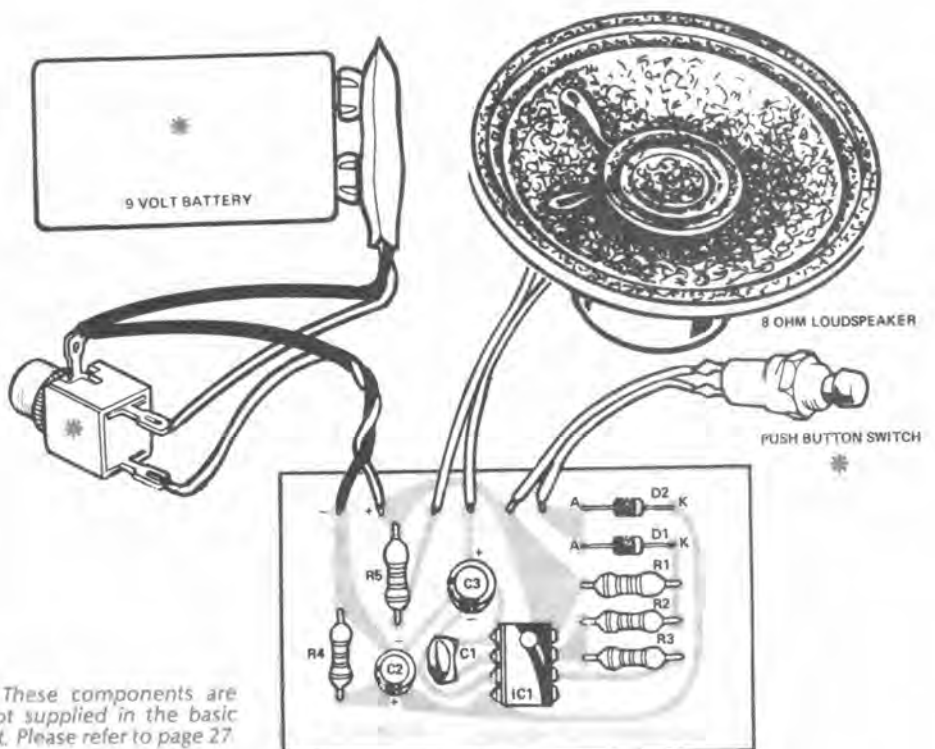

Figure 2

# putting it together . . . continued

**Assembly Hints** for extra information on connecting loudspeakers.

- (7) Solder on the battery snap wires, making sure you have the correct polarity: red (positive) to the pad marked '+' and black (negative) to the pad marked '-'.
- (8) Before you connect the battery check again the components are all in the right place, the correct polarity and are soldered in properly.
- (9) Connect the battery and check the circuit by momentarily shorting the 'PB1' pads together.

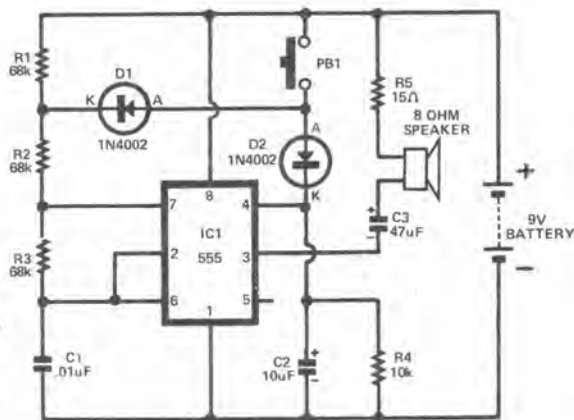

Figure 3: The circuit is very simple, as most of the circuitry is 'hidden' inside the 555 timer IC. This circuit draws a small amount of current at all times, so a plug-pack adaptor is really needed.

## what to do next

The Electronic Doorbell you have made can be triggered in several ways and adapted to many uses.

Apart from mounting it in a Zippy box as shown, and sticking on the attractive label supplied in the back of the book, you can make other circuit modifications to your doorbell.

For example, virtually anything which simulates the shorting together of the contacts of PB1 can be used to switch the 'doorbell'. The **Sound Activated Switch** and **Light Activated Switch** (two later projects in this book) are two ways to switch it. In fact, if you use the **Sound Activated Switch** close to your telephone and connect it to the doorbell, you will have a remote telephone bell without infringing Telecom regulations (see the Sound Activated Switch for more details).

While the circuit operates from a nine volt battery, it draws a small amount of current all the time. Therefore, a plug-pack eliminator is really necessary if you intend setting the doorbell up for serious use: it would be inconvenient to change batteries all the time. Wiring details for a socket to suit the plug-pack eliminator are given in project one. There is no point in fitting an on/off switch to this project.

### Other Ideas

Virtually any press button can be used for a door button – you can even make your own from bent strips of brass! But why not be really smart and make up the '**Touch Switch**', mounting the touch pad near the door. The relay in the touch switch simply replaces the push button: wire the 'normally open' contacts to the pads which would normally be used for the push button on the PCB. All your visitors

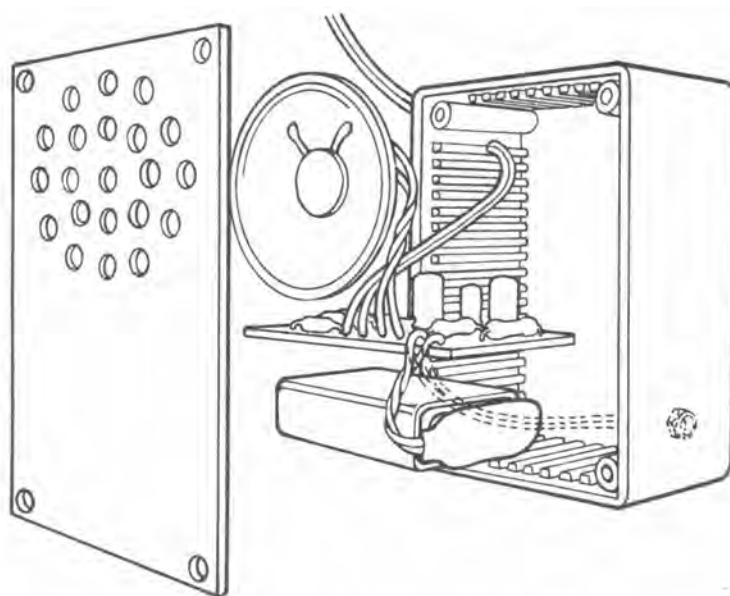

Figure 4: You will need to drill some holes in the front panel for the speaker, but apart from that, fitting the project into a Zippy box is very simple. Holes are also drilled in the box itself for the plug-pack adaptor socket and wires to the push-button. The easiest way to fix the speaker to the front panel is to glue it with 'Araldite' or similar, around the rim of the speaker.

have to do is touch the touch pad – and the doorbell will operate.

To make it even more attractive, you could also build the '**Flasher**' project with the LED mounted behind the touch pad. The flashing LED would make it very easy for your visitors to find the touch pad.

With these ideas to start you off, you will probably be able to think of many more applications and modifications.

This is one of the most satisfying aspects of the electronics hobby: one project leads into another, and another . . .

Remember that every time you build a circuit, or modify an existing one, you are learning a little bit more about electronics. You've probably already discovered just how much fun it can be!

# Milestones in Electronics

## The birth of the Transistor

December 23rd, 1947

Whilst the first transistor was born at Christmas time in New York, U.S.A., in 1947, its beginnings go back a lot further than that. As early as 1874, a German scientist produced a semiconductor diode. That's right, 1874!

This device became popularly known as a 'Cats Whisker'. It consisted of a piece of wire lightly touching the surface of a crystal of Lead Sulphide (Galena or 'fools gold'). The junction of the wire and the crystal formed a diode. The 'Cats Whisker' was a very popular diode detector for radio reception (especially in crystal sets) but it was fragile and cantankerous to use, as you had to move the wire about from time to time to get a better diode junction with the crystal.

Even before that, however, people were discovering that combinations of metals and metal oxides or sulphides could produce rectifying effects, i.e., they would allow current to flow in one direction only.

No-one really knew how these devices worked; they did not know enough about atomic physics at the time. But they were no less fascinated and better rectifiers were produced. As a matter-of-fact one type was a survivor until very recently. This was the Selenium/Copper rectifier. It was made in the millions for battery chargers, voltage doubler circuits etc. It consisted of stacks of alternating Copper and Selenium washers compressed together with an insulated bolt running up the centre. At the point where the Selenium and Copper came together, a diode junction was formed. While each junction was pretty inefficient, you could make the washers large in diameter (for higher current) or stack more washers (for higher voltage).

They survived for so long because they were cheap, easily made, reliable, had a long lifetime and were difficult to destroy. Just about every old Ham has one in his junk box.

By the mid 1920's, most scientists who were interested had a pretty good idea how a rectifying solid state junction worked. By "Solid State" we mean a device that does not use a vacuum to operate. Solid state devices therefore operate within the confines of their solid mass.

The question on everyone's lips of course was "How can I fit a control element in the junction to make a solid state (triode) amplifier?"

The race was on. Unfortunately, World War II diverted many people's attention for a few years, not before a couple of metallurgists at Bell Telephone Laboratories in New York, made a remarkable discovery.

In an effort to produce pure Silicon material for rectifier experiments, J.H. Scarff & H.C. Theurer were confounded to discover that some of their rectifiers worked one way, others not at all, and others the reverse of the first! It was like making tins of paint with the same material, only to end up with black paint one minute, white the next, with the odd can of clear varnish in between!

They concluded that whilst the Silicon that they were making was 'pure', it had microscopic contaminations that radically changed the electrical characteristics of it. There were two types – a 'P' type and an 'N' type. In other words, one conducted one way when biased negatively ('N' type) and the reverse for the 'P' type.

They further discovered that certain impurities (like Phosphorous or Arsenic) produced 'N' type material and impurities like Boron or Indium produced 'P' type material. Knowing this, they then produced the first P-N Silicon diode – in 1940!

After the war, Bell Telephone Laboratories continued to be in the forefront of research into the "solid state triode". Despite the earlier work on Silicon far more was known about Germanium. Research

eventually concentrated on both, however.

A special research division was formed at Bell, headed by William B. Shockley and Stanley O. Morgan, to concentrate on producing, among other things, a solid state amplifying device.

Eventually two scientists under Shockley's direction narrowed their work down to a specific area. The scientists, John Bardeen and Walter H. Brattain, made rapid strides during the latter half of 1947.

On December 23rd, 1947, they did it. In order to make the transistor that they believed in theory would work, they had to use their ingenuity – because the materials they needed had not been made before. For example, they needed wire finer than had ever been produced.

Such problems were overcome and on that historic day they impressed two closely spaced tiny contacts on to a slab of Germanium. The resulting "point contact" transistor had a gain of about 100 and would even amplify audio! It was used in an amplifier circuit that day and their own voices were amplified by it.

The next day it worked as an oscillator.

The device was named the "Transistor" shortly afterwards. It was called this because it provided current gain by transfer of resistance – hence – **trans - istor**.

Whilst Bardeen and Brattain were credited as the actual inventors of the device (they were awarded the patent) Shockley was also credited, as he was the leader of the group responsible for the discovery.

They were all awarded the Nobel Prize in 1956 for their tremendous achievement.

## The superheterodyne ... (c. 1918)

(Also see Edwin Howard Armstrong, page 55)

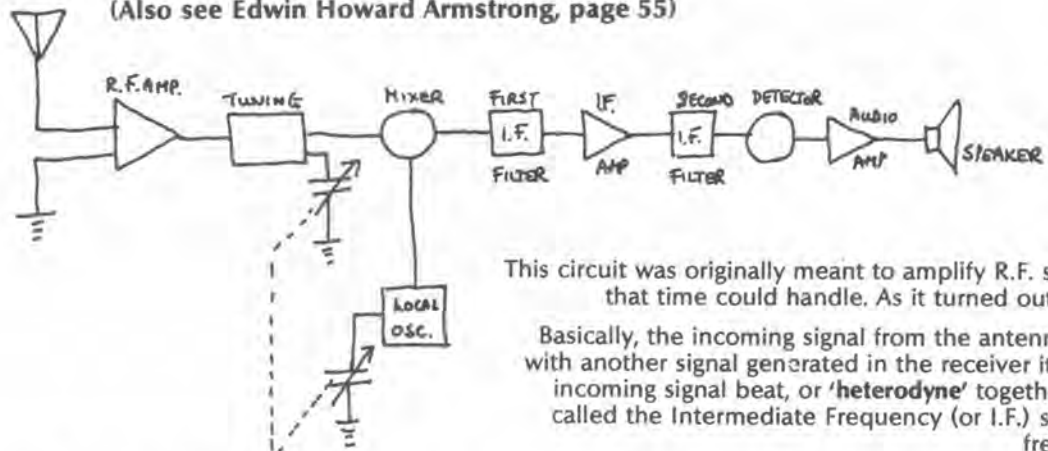

This circuit was originally meant to amplify R.F. signals at a frequency that valves at that time could handle. As it turned out there were also other advantages.

Basically, the incoming signal from the antenna (or RF amplifier circuit) is mixed with another signal generated in the receiver itself. This **local oscillator** signal and incoming signal beat, or 'heterodyne' together, to become one fixed frequency called the Intermediate Frequency (or I.F.) signal. This signal is usually lower in frequency than the original RF signal.

The lower frequency was easier to amplify with the valves that were available at the time. But more importantly than that (valves improved anyway) it was possible to process the I.F. signal to a great degree. In other words the I.F. signal could be fed through highly tuned circuits that very selectively blocked all other signals **but** the I.F. This process, called **selectivity** enabled a receiver to tune between two signals that were very close together, or a weak signal that was very close to a strong one.

The IF signal is then detected and amplified in the normal way (not a part of the 'superhet' circuitry) – see 'understanding radio'. The superhet circuit and what it could do was one of the prime reasons for the phenomenal growth of radio in the 20's and 30's.

# project number three

## Morse Code Trainer

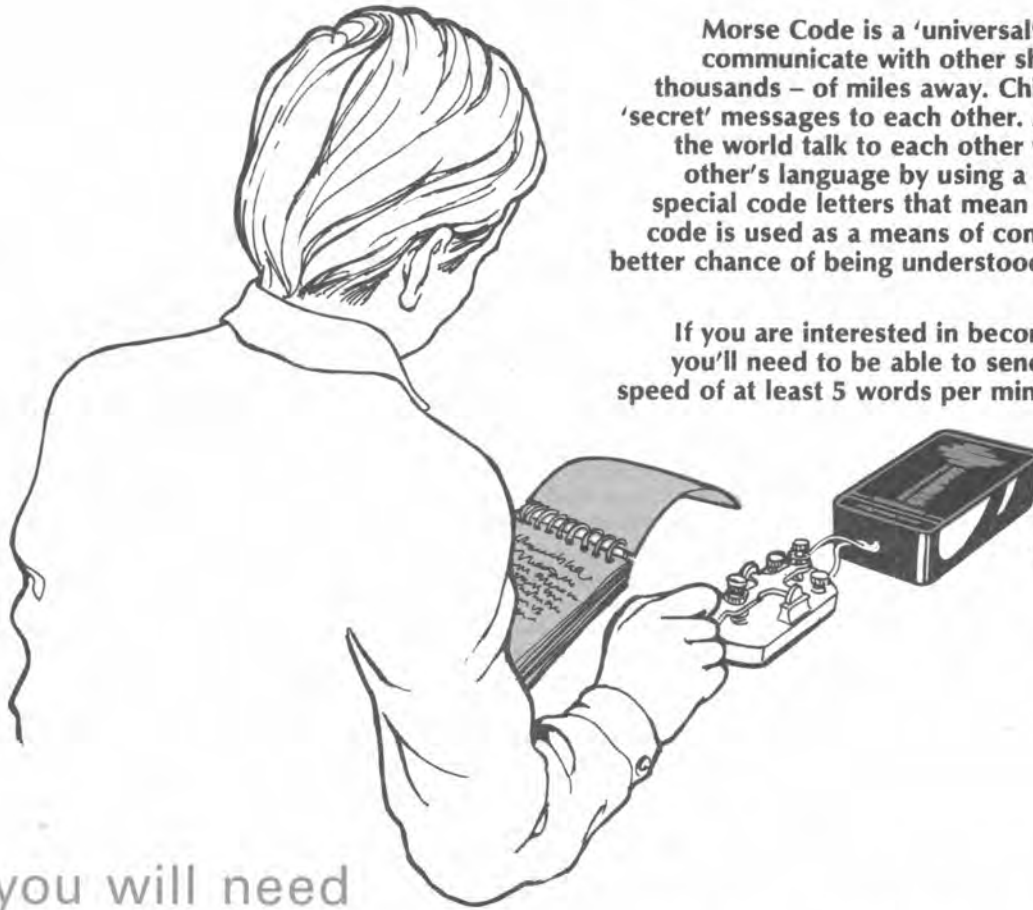

Morse Code is a 'universal' language. Ships at sea use it to communicate with other ships and shore bases hundreds – thousands – of miles away. Children at school use it to tap out 'secret' messages to each other. Amateur radio operators around the world talk to each other without knowing a word of each other's language by using a combination of Morse code and special code letters that mean the same the world over. Morse code is used as a means of communication because it has a lot better chance of being understood in times of difficult conditions: during a storm, for example.

If you are interested in becoming an amateur radio operator, you'll need to be able to send and receive perfect Morse at a speed of at least 5 words per minute (or 10 words per minute for a 'full' licence) before you can pass the amateur operator's licence examination.

This Morse Trainer will help you learn the code, and achieve the speeds necessary. Enjoy it!

### you will need these components

#### Resistors:

- R1 27k ohms
- R2 1k ohms

#### Capacitors:

- C1 .15uF polyester (greencap)

#### Semiconductor Devices:

- TR1 NPN transistor DS548 or similar

#### Miscellaneous:

- T1 1k ohm to 8 ohm audio transformer
- 8 ohm loudspeaker
- Battery snap, solder, hook-up wire

You will also require a 9 volt transistor battery (not normally supplied with a kit) or some other 9 volt DC power supply.

A suitable mounting board or printed circuit board of correct design (DSFW2 K-2623 Morse Code Trainer Kit contains the correct PCB).

We have left the choice of Morse key to you but recommend for beginners, the DSE economy key Cat. D-7105.

There are probably as many circuits for Morse Code trainers as there are Morse Code characters! However, you'll go a long way to find a simpler circuit than this one: just one transistor and four other components. Only one of the other components is polarised (and it will go onto the pcb only one way) so building this project should be very easy, even for a beginner. Go to it!

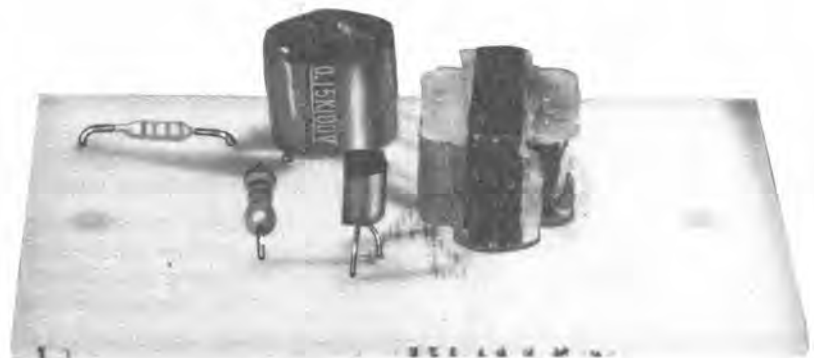

Figure 1

# putting it together

- (1) If you have purchased a kit (Dick Smith Cat. K-2623 or similar), check off the components against the above list to make sure they are all there and are the correct types and values.
- (2) If you have not purchased a kit you will need to obtain the components listed and either make a printed circuit board using the component position drawing as a guide, or use a perforated or tracked board.
- (3) Mount the components as shown in the component position drawing. Place and solder the resistors and capacitor first.
- (4) Position and solder in the audio transformer T1 making sure that you have it the right way around. This should not be too difficult as the primary (1k) side has three leads while the secondary (8 ohm) side only has two and these should line up with the holes in the PCB.
- (5) Taking care with its polarity, position and solder TR1 using a heatsink clip to prevent damage from overheating.
- (6) Solder leads to the loudspeaker and then to the speaker pads on the PCB. See **Project Assembly Hints** for more helpful information on connecting speakers.
- (7) Solder the battery snap to the power supply pads ensuring that you have the correct polarity – red wire to '+' positive and black wire to '-', negative.
- (8) Before you connect the battery check again that all of the components are in the right

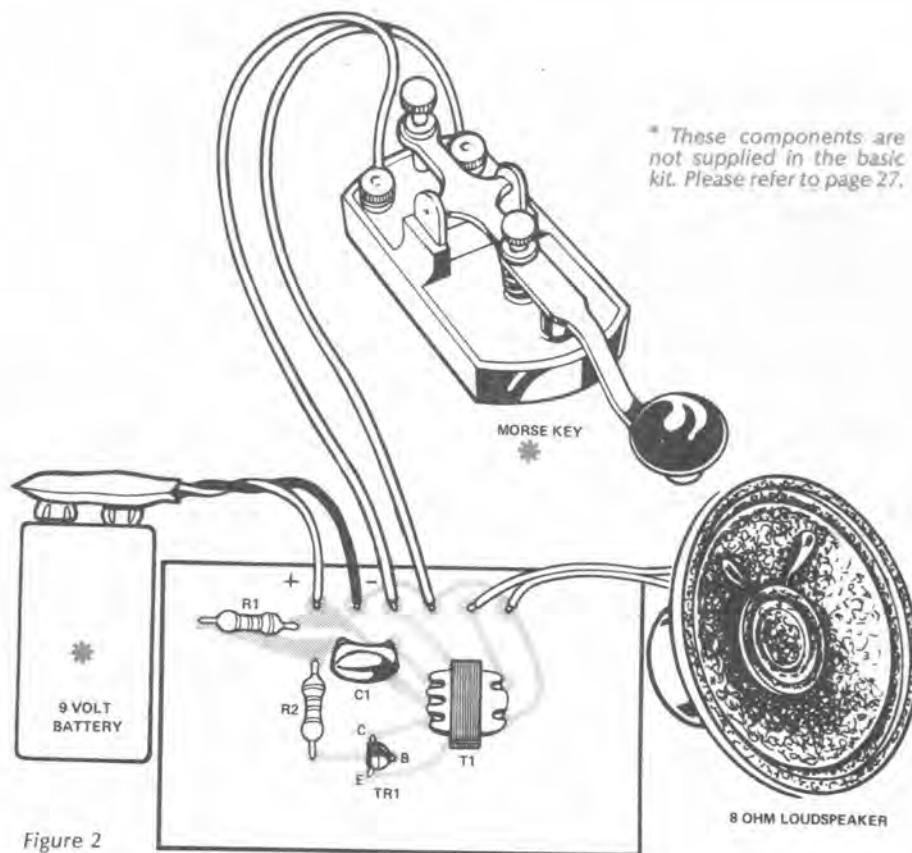

Figure 2

\* These components are not supplied in the basic kit. Please refer to page 27.

- (9) Connect the battery and test the circuit by shorting the input terminals together. This should produce a tone from the speaker, which will go 'OFF' when the short circuit is removed. See **What to do next** for details on changing the pitch of the tone, making a Morse key and learning the code.

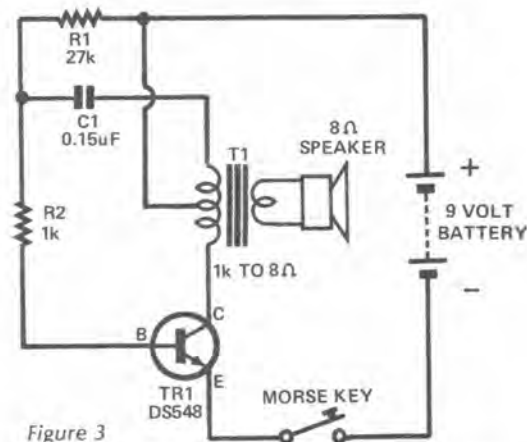

Figure 3

## how it works

The Morse key is simply a switch which completes the circuit while it remains pressed. When the circuit is completed, TR1 immediately turns on because R1 & R2 supply the base current or 'bias' it requires to conduct.

When TR1 turns on, a current flows from the positive supply via the centre tap and the lower half of the transformer, through the transistor and back to the battery. However, the current flowing through the lower half of the transformer 'induces' (or causes) a voltage to occur across the upper half. This voltage is opposite in polarity to the voltage across the lower half.

The voltage also appears across the capacitor (C1), with the end of C1 connected to R1/R2 going negative. This negative voltage is applied to TR1's base via R2 – which immediately turns off TR1. The magnetic field collapses, and the circuit is ready to start the cycle all over again.

Each time the magnetic field changes in the primary of T1, a current is induced in the secondary. The speaker is connected to the secondary, so the secondary current also flows through the speaker. The speaker cone deflects, causing air particles to be vibrated.

As the cycle repeats many, many times each second, many, many air particles are vibrated by the speaker. We hear this as continuous sound. The frequency is dependent on the time constant of R1, T1 and C1. The pitch may most easily be changed by changing the value of R1 – increasing the resistance will decrease the pitch and vice versa.

This type of circuit is called a 'blocking oscillator': each time the transistor conducts it is blocked by the reverse voltage across the transformer removing its bias.

## what to do next

There are a number of ways you can make your own Morse key but one simple way is to fashion a key from a piece of bent tinplate or brass and a drawing pin attached to a piece of wood. However, unless you have a reasonable key it may interfere with your learning and we suggest that investing in even a cheap key is worthwhile. The Dick Smith Cat. D-7105 economy Morse key is suitable and retails for less than \$2.00 at the time of printing.

Mounting your **Morse Code Trainer** in a box will make it more readily portable and protect the components as well as giving the speaker a sounding box to improve its tone and volume. Figure 4 is an exploded view of the project showing how to mount the various components and connect them up. The attractive label is supplied in the back of this book and will give your project a truly professional look.

If you intend using your trainer a fair amount you may prefer to save batteries by using battery eliminator such as the DSE Cat. M-9525 and the P-1231 socket. The wiring for this socket is shown in many of the projects in this book.

As mentioned earlier the oscillator may be used as an audible alarm by connecting relay contacts in place of the Morse key. As we explained in 'How it Works', the Morse key is simply a switch in the supply: any other form of switch in this position is satisfactory.

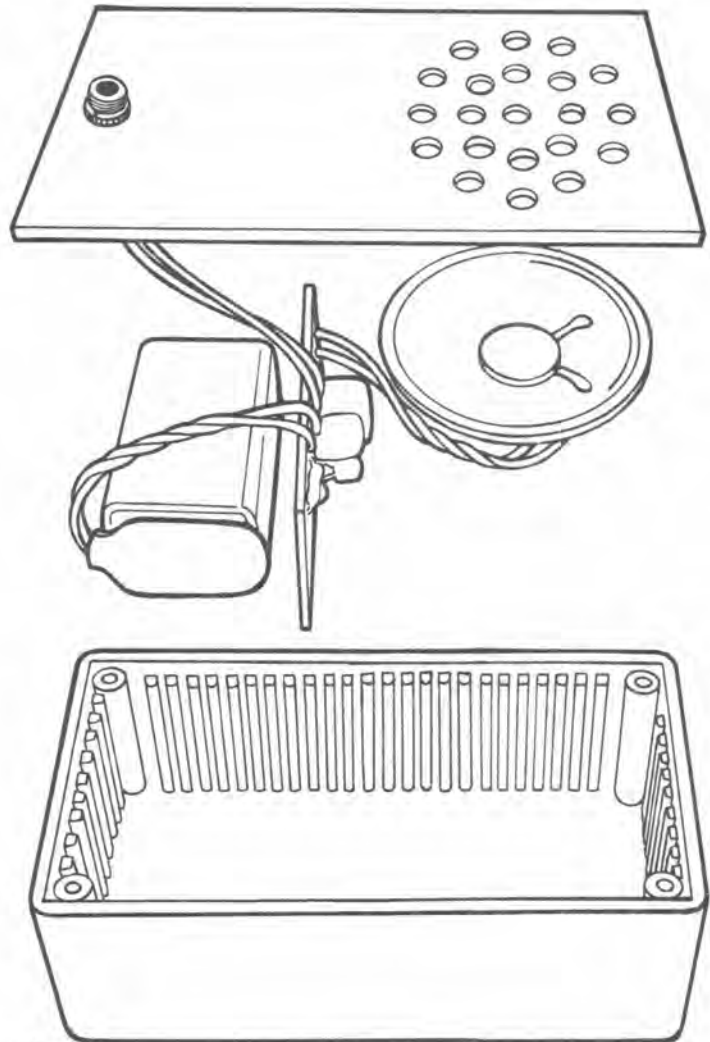

Figure 4

See the last pages in this book for a plan to drill your front panel, and an attractive overlay showing the Morse Code.

## Dr Samuel Morse (1791 – 1872)

Samuel Finley Breese Morse, the inventor of the code which bears his name, was born in Boston, USA, and educated at what is now the famous Yale University.

Morse studied painting in England, and was a successful artist. He helped found the National Academy of Design in New York City.

He became interested in electrical experiments in the early 1830's and developed apparatus for a magnetic telegraph in 1836. About this time, he also developed a code consisting of long and short sounds, which could be transmitted by means of his telegraphic instrument.

In 1843, the United States Government appropriated \$30,000 (a huge sum in those days) for Morse to construct an experimental telegraph line between Washington, DC, and Baltimore, Maryland – a distance of approximately 50km.

On May 24th, 1844, Morse successfully sent the first code message over this line: the now famous phrase 'What hath God wrought!'

Morse was involved in much legal wrangling over his claim to the invention of the telegraph, with the courts finally deciding in his favour. He received financial rewards and many honours.



# Learning the Morse Code

Why not make a copy of this page and pin it to your wall. It will make learning easier!

Each letter, numeral and punctuation mark is represented by its own individual series of sounds. In time, you will be able to recognise these sounds as belonging to that letter alone; eventually, with enough practice, you should not have to listen to the individual sounds of the letter in order to work it out, but be able to recognise the group of sounds as a whole as representing that letter.

Before we go any further, let's try to get on the right track and correct an all-too-common error made by people trying to learn Morse. The code is NOT made up of dots and dashes! If you try to visualise Morse as a series of dots (•) and dashes (–) you will never achieve any real speed. Because Morse is an 'Aural' language (that is, received by the ears and not by the eyes) it should never be represented in dot and dash form.

Instead, try to think of Morse as 'dits' and 'dahs'. A 'dit' is a short, sharp note, made by quickly pressing the key and releasing it. A 'dah' should be three times longer than a dit – you hold the key down for three times as long.

Between each group of dits and dahs making up individual letters, there should be a silence roughly equal to the length of a 'dah'. And between each word sent in Morse Code there should be a slightly longer gap – around two 'dahs' long.

The easiest letters to learn are the single sound letters: E (dit) and T (dah). Practise them on your code trainer, saying them aloud as you send them over and over.

All other letters and numbers are numbers of dits, numbers of dahs, or combinations of dits and dahs. You will have noticed that in the list of Morse sounds that some 'dits' are shown as di' . . . When ever a 'dit' sound is followed immediately by another sound (either dit or dah) we leave off the final 't'. For example, for the letter 'B' we say dah di'di'dit, instead of dah dit dit dit. Say these two aloud: see how much more easily the first combination rolls off your tongue?

While this Morse Trainer will allow you to learn transmitting properly, it cannot teach you to receive. For this, you need to listen to someone else (who is proficient at sending Morse) and gradually increase the speed. If you live close to an amateur radio operator (you'll recognise an amateur's house by the number of aerials!) why not ask him if he'll help. Most amateurs are only too pleased to help out someone who is genuinely interested: they remember how hard it was for themselves!

Alternatively, you can listen to specially prepared Morse Code tapes (such as Dick Smith Cat. No. D-7106) which you can play as often as you like. A third alternative, for those with access to a short wave receiver, is to listen to the nightly 'slow Morse' transmissions' conducted by the Wireless Institute of Australia specifically for the purpose of teaching Morse Code reception. Times of transmission vary from state to state, but are generally around 7 to 9 PM, in the 80 metre amateur band, usually around 3.55MHz. The short wave receiver project in this book is capable of receiving this band, but tuning is a little tricky!

## The international Morse Code

A	di'dah	G	dah dah dit	M	dah dah	S	di'di'dit	Y	dah di'dah dah
B	dah di'di'dit	H	di'di'di'dit	N	dah dit	T	dah	Z	dah dah di'dit
C	dah di'dah dit	I	di'dit	O	dah dah dah	U	di'di'dah	.	di'dah di'dah di'dah
D	dah di'dit	J	di'dah dah dah	P	di'dah dah dit	V	di'di'di'dah	?	di'di'dah dah di'dit
E	dit	K	dah di'dah	Q	dah dah di'dah	W	di'dah dah	Error	di'di'di'di'di'di'dit
F	di'di'dah dit	L	di'dah di'dit	R	di'dah dit	X	dah di'di'dah		

1	di'dah dah dah dah	6	dah di'di'di'dit
2	di'di'dah dah dah	7	dah dah di'di'dit
3	di'di'di'dah dah	8	dah dah dah di'dit
4	di'di'di'di'dah	9	dah dah dah dah dit
5	di'di'di'di'dit	0	dah dah dah dah dah

The 'International' Morse Code we know today is an adaptation of Morse's original code, called the 'Continental' Code. It differs in only a few respects: if one code is known thoroughly, it is usually possible to reasonably understand the other.

# project number four

## Universal Timer

Remember the old egg-timer? Turn it up-side down, wait until all the sand falls through to the bottom and the egg was cooked. Maybe!

Trouble was, different people liked different timed eggs. Some liked the basic three minuter. Others more a four. Still others a little less. The sand egg timer just couldn't cope!

Problem solved: electronically! Dial the time you require, turn it on, and wait. After the time you've requested, it beeps. If someone wants a longer time, set it longer. Everyone is satisfied!

Of course, it can time more than eggs. This simple timer circuit has a range of a few seconds to around 15 minutes. And you can use it to turn a device on for a given time, then off again, if you wish (instead of the other way around as with the buzzer).

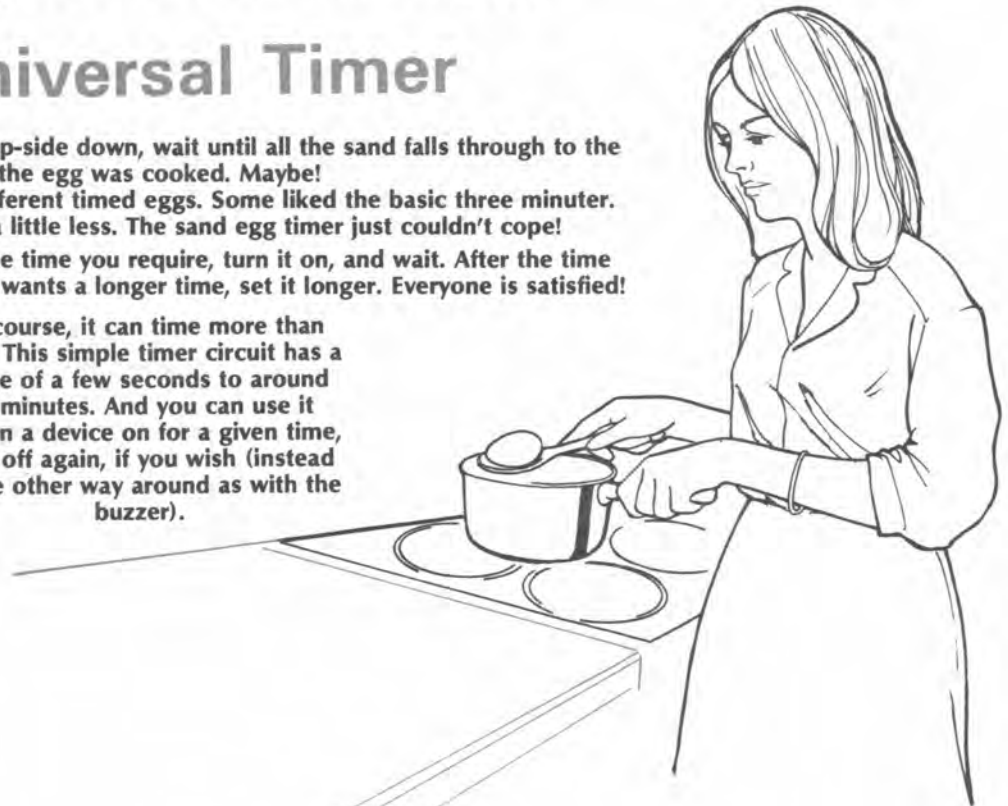
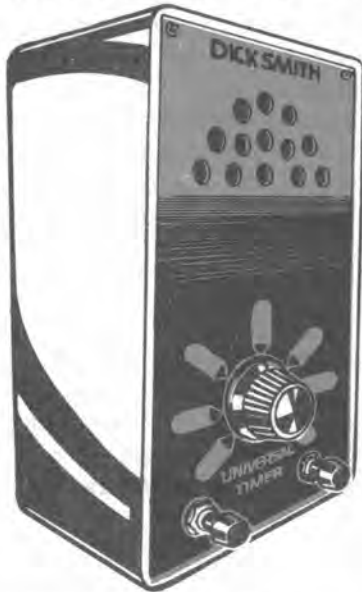

### you will need these components

#### Resistors:

- R1 10k ohms
- R2 6.8k ohms
- R3 47k ohms
- RV1 1M ohm potentiometer

#### Capacitors:

- C1 .01uF polyester
- C2, C3 47uF 6.3 volt tantalum electrolytics
- C4 .01uF polyester

#### Semiconductor Devices:

- TR1 DS558 or similar PNP transistor
- D1, D2 1N914 silicon diodes
- D3 1N4001 or 1N4002 silicon diode
- IC1 555 timer integrated circuit

#### Miscellaneous:

- PB1 Momentary action push button switch
- Rly 1 Miniature relay with 9V coil, single changeover contacts

Battery snap, solder, hook-up wire

You will also require a 9V battery (not normally supplied with a kit) or some other DC supply, and a suitable mounting board or printed circuit board of correct design (DSFW2 K-2624 Universal Timer kit contains the correct PCB).



Figure 1

In the past, electronic replacements for kitchen gadgets haven't proved popular because of complexity of operation. This simple circuit should solve that problem.

Using it is simple. First turn on the power switch, and it beeps at you (just to show the battery is ok and all is well). Dial the time wanted, and press the 'time' button. The sound ceases, and will not occur again until the selected time has expired. It will continue to sound until you turn it off. It's that simple!

If you wish, the circuit can be reduced to single-button operation by using a 'double pole' switch (one action turns the circuit on and triggers the timing function). While this reduces the number of switches required, it also eliminates the self-checking function of the beeper sounding when the first switch is turned on, as above. (See 'what to do next' for more details).



# putting it together

- (1) If you have purchased a kit (Dick Smith Cat. K-2624 or similar), check off the components against the above list to make sure they are all there and are the correct types and values.
- (2) If you have not purchased a kit you will need to obtain the components listed and either make a printed circuit board using the component position diagram as a guide, or use a perforated or tracked board.
- (3) Mount the components as shown in the component position drawing. Place and solder the resistors first, being extra careful to mount the two 47 $\mu$ F capacitors the right way around as they are polarised. In this case the leads marked '+' go on the inside, nearest the transistor. Check that all components are 'dressed' or positioned neatly before soldering them in.
- (4) RV1 and the relay can now be placed in position and soldered. Both of these components will only fit one way easily, so if you are having trouble the pins may be bent or you may be trying to put it in the wrong way.
- (5) Great care must be taken when placing the three diodes D1, D2 and D3, firstly to ensure that you have the correct diode and then, that you have it the correct way around. D1 and D2 are 1N914 diodes – the smaller glassy looking ones with a black band at one end – while D3 is a 1N4002 diode, the larger black one with a silver band. Mount D1 and D2 as shown, with the black bands both towards the transistor and D3 with its silver band inwards.
- (6) Mount the transistor in the correct place with its flat side towards the relay. Double check that it is in the correct position and the right polarity by noting that the centre pin (base) is joined to the banded end of D2 by the PCB track, while the emitter goes to pins 6 & 7 of IC1 and the positive ends of C3 & C4, as is shown in the circuit diagram and the component position drawing. Solder it in, using a heatsink clip to prevent damage by overheating.
- (7) Now to IC1 the 555 timer integrated circuit. Perhaps this is

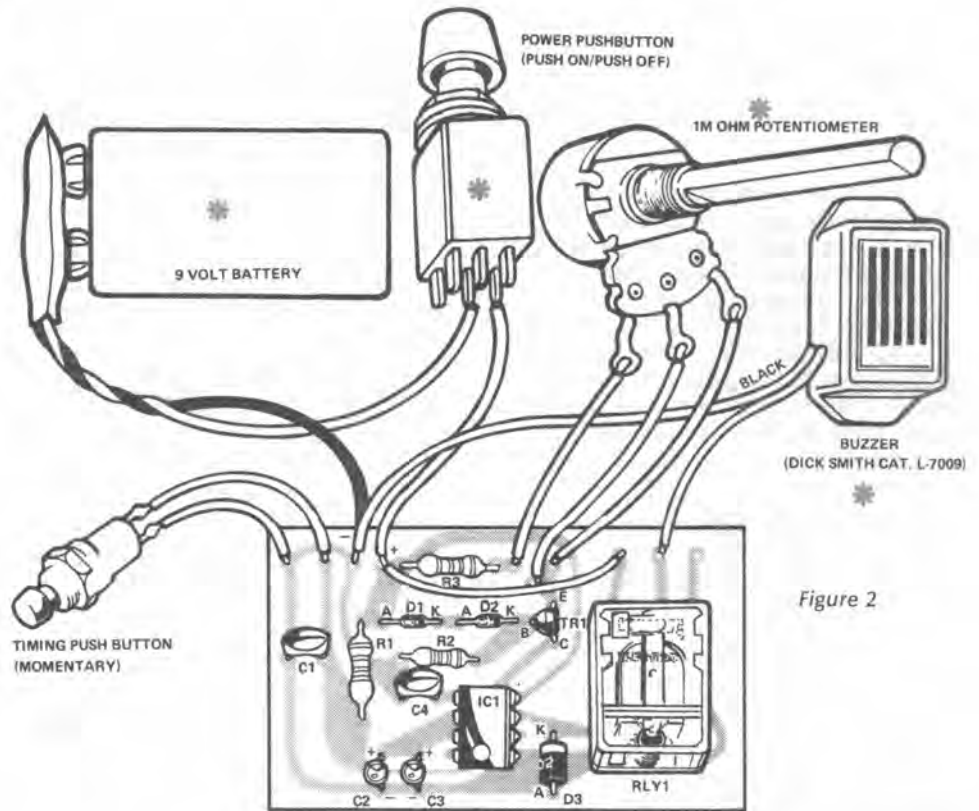

Figure 2

\* These components are not supplied in the basic kit. Please refer to page 27.

the first IC you have ever soldered in, but don't panic! It is not really difficult provided you are careful and follow these steps: insert the integrated circuit into the holes on the PCB until the little shoulders on the pins prevent it from going further; make sure it is the right way around, by noting that pin 1 (the one marked with the circle indented into the top of the IC) is in the corner nearest D3 and that it goes to the track leading to the negative side of the battery; then turn the board over and carefully solder each of the pins to the pads, making sure you don't run solder between the pads. While it is important not to overheat the integrated circuit, it is just as important to apply sufficient heat to obtain a correctly soldered joint. (see **How to Solder**) Inspect the connections to make sure you've soldered them all without shorting out any of the pads and that's it. Easy, wasn't it?

- (8) Solder on the battery snap wires, again taking care to see that you have the correct polarity – red (positive) to the large pad forming the junction of R1, D1

and R3, and black to the long negative track that connects with C1, C3 and C4 as well as other components.

- (9) Connect whatever type of triggering means you desire (see **What to do next**) to the pads shown in the drawing with just two wires connected.
- (10) Before you connect the battery check again that all of the components are in the right place, the correct polarity and soldered in properly.
- (11) Connect the battery and trigger the timer by shorting the bared ends of the trigger wires together – the relay should operate immediately and stay operated when the trigger wires are parted. The time that the relay holds 'ON' will depend on the adjustment of RV1. Note the time that it stays 'ON', then adjust RV1 if necessary to obtain the time period you require.

Read on to **What to do next** for exciting ways you can put your Universal Timer to use and inventive ways of triggering it.

# how it works

This circuit, like the doorbell (project 2) uses a 555 timer integrated circuit. Here, however, the IC is not connected to oscillate, but to time one period only.

The 555 timer works by sensing voltage levels, and acting when certain levels are reached. These levels are called 'threshold voltages', and different pins sense different thresholds. For example, if the voltage at pin 2 falls below  $\frac{1}{3}$  of the supply voltage, the IC turns on. It doesn't matter if the voltage rises again, or falls again: once the threshold is reached and the IC turns on, pin 2 is virtually disconnected.

Conversely, if the voltage at pin 6 rises above  $\frac{2}{3}$  of the supply voltage, the IC will turn off. Once again, this pin does

not have any further function until the IC is turned back on again.

We make use of both of these 'thresholds' in this circuit. As you can see, pin 2 is normally held at the positive supply voltage by R1. When the push button is pressed, pin 2 is taken down to the negative supply, obviously passing its threshold on the way. The IC then turns on; current flows from pin 3 through the relay, pulling it in.

Until the IC turned on, pin 7 was connected to the negative supply via internal circuitry in the IC. Once it conducts, this connection is removed.

D1, D2, R3, RV1 & T1 form what is known as a 'constant current source'. A known, and very stable, amount of current is able to flow through TR1

and charge C2 & C3 (being in parallel, they are effectively one capacitor). The charging current is dependent on the setting of VR1.

As C2 & C3 charge, the voltage across them rises. After a time, this voltage reaches the pin 6 threshold – and the IC turns off. Pin 3 stops supplying current to the relay, which opens. The timing period is thus over.

D3 is connected across the relay to prevent damage to the IC. As the relay drops out, the collapsing magnetic field induces a 'voltage spike' across the relay. This could, in theory, be high enough to damage the IC, so D3 short circuits this voltage and prevents any damage occurring.

# what to do next

The Universal Timer you have made is simply a timed switch, a device which may be triggered and arranged to perform its timing function in a variety of ways.

For example, it may be triggered 'ON' by a simple press button and the relay contacts wired to switch either 'ON' or 'OFF', to sound a warning (you could connect it to the siren described in this book) or to stop a process.

## Kitchen Timer

Figure 3 is an exploded view of the Universal Timer used as a kitchen timer, as shown in the drawing at the start of this project.

As you can see from the drawing, this is done by the addition of two small pushbuttons (DSE Cat. S-1102 & S-1205), a small buzzer (DSE Cat. L-7009 is ideal) and a 1M ohm potentiometer (DSE Cat. R-1813), wired into the circuit as described and all placed in a Zippy box (DSE Cat. H-2753).

Use the handsome label supplied in the back of the book to give your timer a really professional look. When you have it set up and operating, set the knob to each of the white calibration positions on the label, and measure the time period with a watch. Mark the label with each time measured.

(The reason we cannot print a pre-calibrated label is that each timer will be slightly different due to component tolerances. It is better to calibrate your own label to suit the components in your timer).

## Connecting it up

Refer to the wiring diagram to double check your wiring, connect the

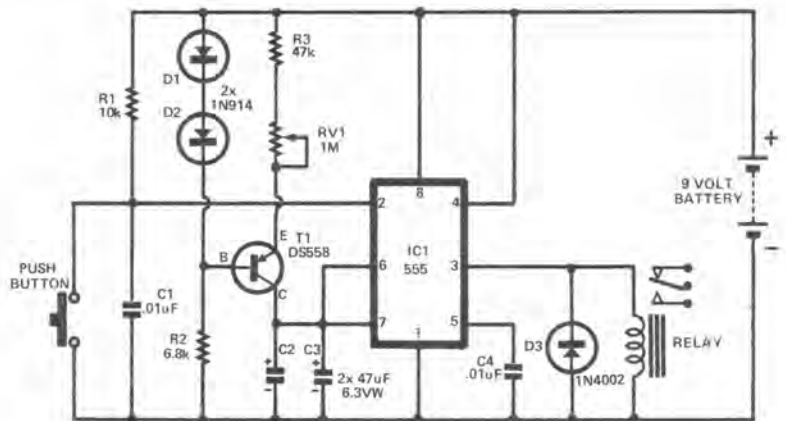
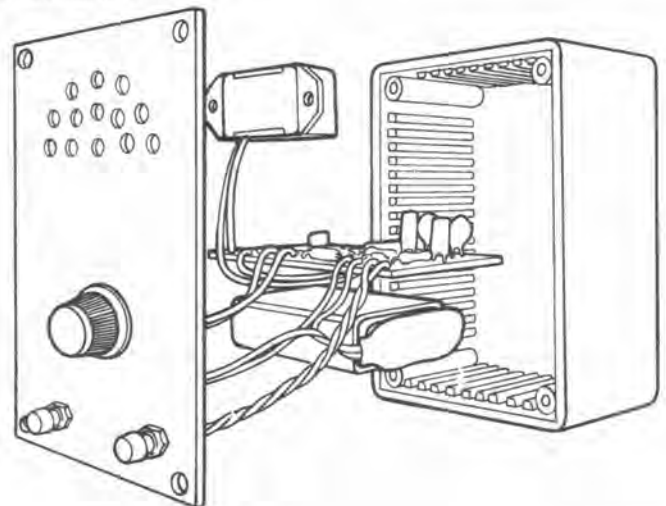

Figure 4: The circuit diagram of the Universal Timer. The relay contacts can be used to switch devices either 'on' or 'off' for the time period, simply by selecting the 'NO' or 'NC' contacts. (See the section on relays elsewhere in this book if you don't know what these terms mean).

Figure 3: This is how it all fits into a Zippy box: including the buzzer which is simply switched on and off by the relay contacts. For serious use, a further addition might be a 3.5mm socket for external power.



## what to do next . . .continued

momentary action push button, the power push button, battery snap and buzzer. Note the colour coding of the wires to the various components.

As we mentioned at the start of this project, a single push button can be used to replace the two described above. You'll need a double pole switch (double pole is another way of saying two switches in one package).

If you look at the back of the double pole switch, you'll see there are two sets of three terminals. Each of these sets of terminals is treated as a separate switch, and is wired just as the two separate switches above.

The 1 megohm potentiometer shown replaces the trimpot supplied in the kit. They are electrically equivalent, but the larger variable pot is more convenient to use. The three leads on the large pot replace the three leads on the trimpot: they connect in the same order (ie left to left, centre to centre and right to right).

Mount all of the components in the zippy box as shown in Figure 3. You might like to add a knob – the one shown is DSE Cat. H-3762, but almost any knob will do.

If you want to use the timer regularly, you won't want to be buying batteries all the time. In project one we show connection details for a 3.5mm socket, which will enable you to use a plug-pack adaptor such as the DSE Cat M-9295 versatile battery eliminator or something similar.

### Darkroom Timer

To adapt the Universal Timer for darkroom use, set it up exactly the same as for a kitchen timer, with one exception: change R3 to a 4.7k. This lowers the minimum time to around 4 seconds: much more useful in the darkroom. Of course, your calibration will now be for a much shorter time range.

Instead of the buzzer, you might like to use a red LED for darkroom use (this doesn't have to be turned off immediately – it isn't annoying!) If you use a LED, connect as per the buzzer, but place a 470 ohm resistor in series with the LED to protect it. Connected in this way, the LED will come on at the end of the timed period. If you wish to reverse the sequence, simply connect the LED to the 'NO' (normally open) contacts of the relay.

Perhaps you would like to have the timer automatically turn your enlarger on and off. Easy! But there is a snag: the relay probably won't be able to handle the current drawn by the enlarger bulb, so you may have to use

a power relay in series with the pcb relay. (See 'using relays' at the start of this book).

Of course, there is nothing to stop you doing both of the above: a LED and a controlled enlarger. Even better, you could connect the enlarger relay to the 'NO' contacts and the LED to the 'NC' contacts, so the LED shows when the enlarger is off. There are a large number of variations possible: see what you can work out.

### Other uses

Because it is so small and versatile, the Universal Timer can be built into a whole range of equipment that operates on a timed cycle. Building security lights, alarm delays, etc, etc – see how many uses you can find for a timing circuit like this one!

If you wish to operate the timer with a device having a different supply voltage, don't worry if the voltage is in the range of, say, 6 to 15 volts. The circuit will operate happily over this range. If the voltage is outside this

range, it would be best to revert back to the battery or plug-pack supply giving around 9 volts.

### Different triggering methods

There are many other ways of triggering the timer, and you might like to try some of them. All that is necessary is some means of shorting C1 (that is, connecting its top connection to the negative supply). Any of the projects in this book which operate a relay could be used to do this (the light activated switch, sound activated switch, touch switch, etc).

You could use the delay in conjunction with one of these other circuits. For example, how about the light or sound activated switch operating boom gates on a model railway, with the time delay keeping the gates closed until well after the last carriage has passed?

There are many things you will find around you that could trigger the delay.

## Michael Faraday

(1791 – 1867)



Like Edison (see page 51), Michael Faraday had little formal education. He was born in London, England, the son of a blacksmith.

Faraday was apprenticed as a bookbinder, but was a scientist at heart. In his spare time, he read countless books on scientific subjects. He also experimented with electricity.

At the age of 21 he attended a series of lectures given by the famous British scientist, Sir Humphrey Davy. Faraday was very impressed and sent Davy an application for employment along with the copious notes he made at the lectures. Faraday succeeded in gaining employment with Davy as a laboratory assistant. A year later Davy took Faraday with him on a tour of Europe.

Following in Davy's footsteps, Faraday's early research was in the field of chemistry. He even made several fundamental discoveries in this field.

What makes Faraday worthy of note, however, are his discoveries in the areas of electricity and magnetism. He successfully demonstrated magnetic induction and the concept of the magnetic field.

Many of Faraday's discoveries form the basis of scientific knowledge on electro-chemistry, magnetism and electricity right up to today.

He rightly received many honours during his career.

# project number five

## Electronic Dice

This is a very versatile project! Imagine an electronic dice which not only 'rolls', then displays the result, but then turns off automatically! And if you wish, you can build two dice into the same box for games such as backgammon, monopoly, etc.

But it is even more than this: the circuit can be modified to make the latest electronic jewellery or, if you prefer, a LED 'chaser' circuit.

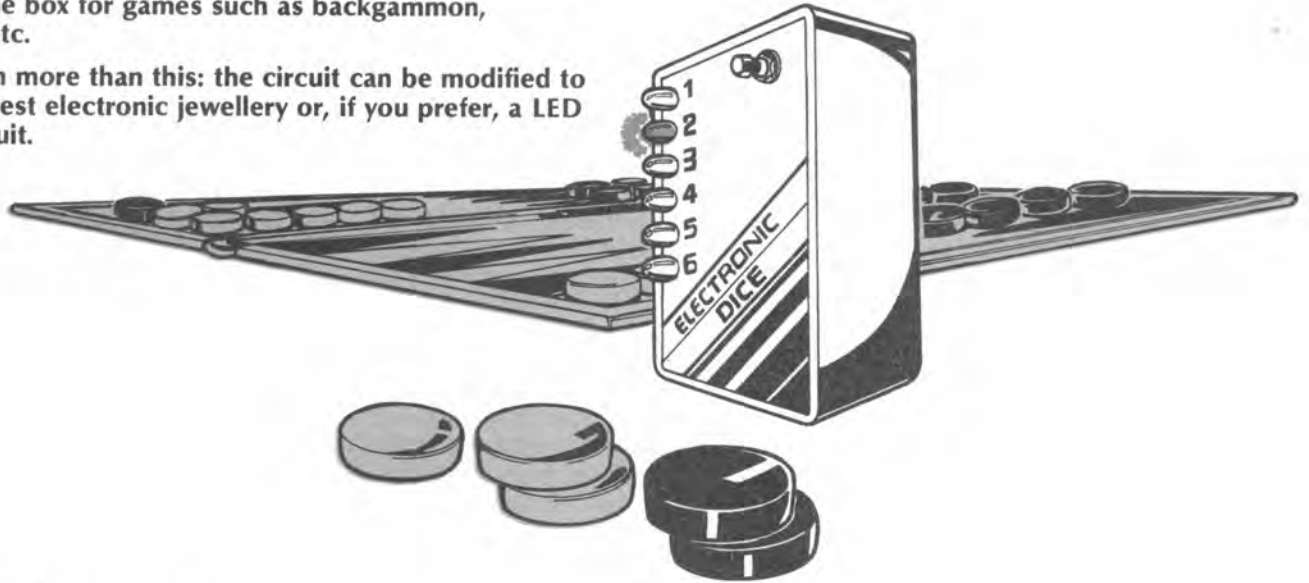

you will need  
these components

### Resistors:

- R1 22k ohms
- R2 220k ohms
- R3 1k ohms

### Capacitors:

- C1 .022uF ceramic or polyester (dice)  
(For jewellery use 3.3uF 10V electrolytic  
– not supplied in basic kit).
- C2 33uF 10 volt electrolytic
- C3 4.7uF 16 volt electrolytic

### Semiconductor devices:

- LEDs 1 – 6 small red LEDs
- D1 1N4001 diode
- IC1 555 timer integrated circuit
- IC2 4017 CMOS decade counter  
integrated circuit
- TR1 DS548 or similar NPN transistor

### Miscellaneous:

- PB1 Momentary contact press button  
switch  
Battery snap, hook-up wire,  
solder, etc

You will also require a 9 volt transistor battery (not normally supplied with a kit) or some other DC power supply.

A suitable mounting board or printed circuit board of correct design (see text). DSW2 K-2625 Electronic Dice kit contains the correct PCB.

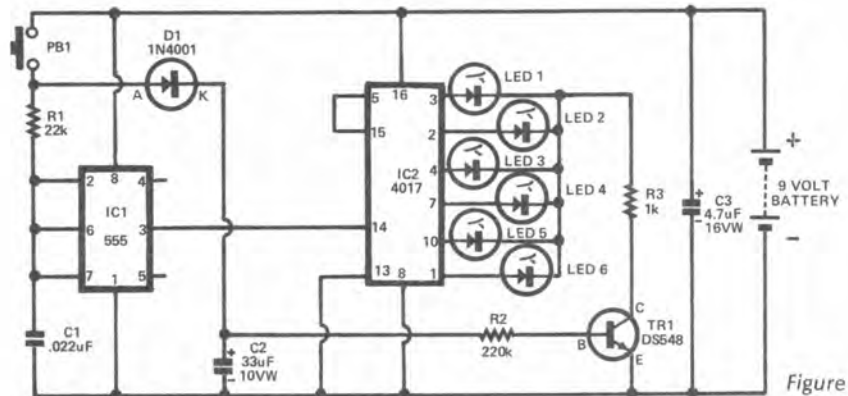

Figure 1



Figure 2

## how it works

When the push button switch PB1 is pressed, power is supplied to C1 via R1. C1 gradually charges, until a certain voltage is reached where IC1 conducts, supplying a pulse to IC2 at the same time as it discharges C1. IC2 then starts to charge again, repeating the process.

The combination of R1, C1 & IC1 is called a 'relaxation oscillator', as every time a pulse occurs, the circuit 'relaxes', ready to start over.

IC2 is a counter, which simply detects the pulses supplied by IC1 and counts them. It shows how many pulses it has counted by causing a LED to glow representing that number. This IC can, in fact, count to ten; however, we want it to count up to six. So instead of causing a LED to glow on the seventh pulse, the pin which would be used for this purpose (pin 5) is connected to another pin which causes the counter to re-set to zero, ready to start counting again.

The counter keeps counting while pulses keep arriving. When the push button is released, the oscillator stops and no more pulses are received. The counter then shows what it had counted to at that particular instant.

Because we do not want the LED to stay on indefinitely (wasting the battery), a separate circuit causes the LED to go out after a short time. This circuit consists of D1, C2, TR1 and its associated resistors.

Whenever the button is pressed, C2 is charged via D1. This allows TR1 to turn on. When the button is released, the charge in C2 dies away through R2 and the base/emitter junction of TR1. After a short time, the current through the transistor becomes too small to keep it conducting, so it turns off and the LED is extinguished.

With the .022uF capacitor shown, the LEDs will flash in sequence so quickly that they all appear to be on at once (although dimly). This is necessary so that anyone using the dice will not be able to cheat by releasing the button at a certain time to obtain a certain number.

Increasing the value of R1 and/or C1 will cause this speed to slow down, due to the longer charging time required. Wired as a flashing brooch, with a 3.3uF capacitor in C1 and a link across the 'PB1' pads, the LEDs will flash slowly in sequence as long as the battery is connected.

## putting it together

- (1) If you have purchased a kit (Dick Smith Cat. K-2625 or similar), check off the components against the above list to make sure they are all there and are the correct types and values.
- (2) If you have not purchased a kit you will need to obtain the components listed and either make a printed circuit board using the component position drawing as a guide, or use perforated or tracked board.

same length to facilitate mounting in a box if you wish to do this later on, as described in 'What to do Next'.

- (5) Solder in D1 after making sure that you have it the right way around, that is, with the banded end nearest TR1.
- (6) Solder in TR1, taking care that it is the correct polarity and using a heatsink clip to prevent damage from overheating. Note that the

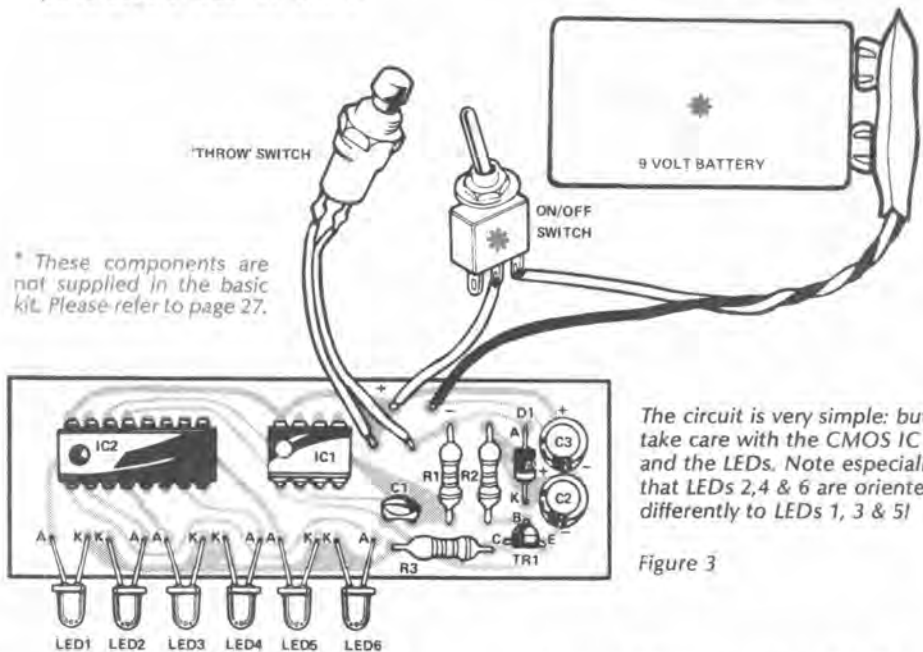

The circuit is very simple: but take care with the CMOS IC and the LEDs. Note especially that LEDs 2, 4 & 6 are oriented differently to LEDs 1, 3 & 5!

Figure 3

- (3) Mount the components as shown in the component position drawing, resistors and capacitors first, being careful to mount C2 and C3 capacitors the right way around as they are polarised. If you are building the brooch, C1 is also an electrolytic and requires the same caution as C2 and C3 in mounting. It is possible that in some cases you will have an axial electrolytic to mount on the PCB. If there is space provided between the holes you can mount it flat as you would a resistor, but if there is not, stand it up as shown in the section on 'Assembly hints and tips'. Take extra care that you get the polarity right in this case. Check that all components are neatly placed and properly 'dressed' before soldering them in.
- (4) Solder in the six LED's making sure that they are the correct polarity - remember that the short lead is the cathode (K) also marked by the flat side of the LED. Keep all of the leads the

base of TR1 connects to R2. Be particularly careful when soldering on this board as some of the tracks and pads are very close.

- (7) Now IC1 the 555 timer integrated circuit. This may be the first IC you have ever soldered in but don't worry, just follow the steps; insert the IC into the holes on the PCB until the shoulders on the pins prevent it from going further; make sure it is the right way around by noting that pin 1 (the one marked with the small circle indented into the top of the IC) is connected to the negative track on the PCB; then turn the PCB over and carefully solder each of the pins to the pads, making sure that you don't run solder between the pads. See **How to Solder**, for the correct method of soldering an IC. When soldering is complete inspect the connections, making sure that you've soldered them all without shorting any of the pads and that's it. Easy wasn't it?

# putting it together . . .continued

- (8) The 4017 integrated circuit is a CMOS device and therefore very sensitive to static electricity. This is why it is supplied already stuck into special conducting foam which shorts out all the pins and prevents damage from static charges. **Leave it in the foam until you are actually ready to solder it in.** Then, being very careful not to touch the pins, insert the IC into the holes provided making sure you place it the right way around the first time as having to remove it to turn it around increases the risk of damage. Pin 1 (the one marked with the small circle indented into the top of the IC) is connected to LED 6. The reason we have used such an apparently fragile IC is that it is very efficient and places a very small drain on the battery compared with less sophisticated devices. Carefully solder the IC in position, soldering pins 8 and 16 in first. (See **How to solder**).

- (9) Solder on the press button wires and connect and solder them to the PCB to the pads marked PB1. You are now ready to connect and solder the battery snap wires, taking care to see that you have the correct polarity – red, positive, to the pad marked '+' and black negative to the pad marked '-'.

- (10) After checking that all components are correctly inserted and soldered, connect the battery and check that the circuit works by pressing the button. All LEDs should appear to come on dimly; one should come on brightly when you release the button, then slowly die out.

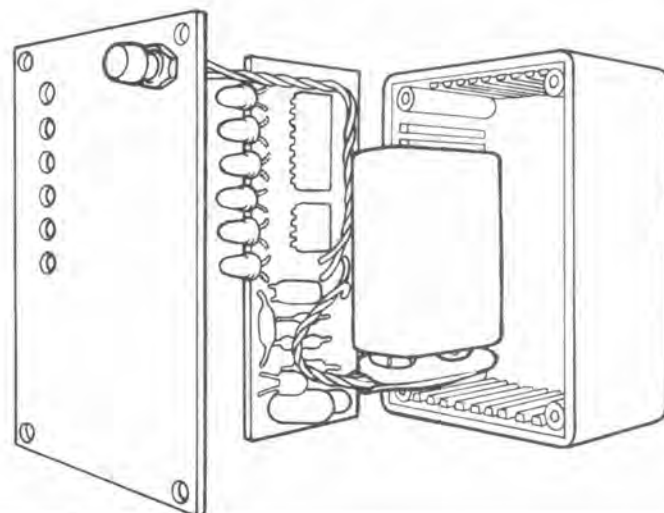

Figure 4: A single LED Dice PCB fits easily into the Zippy box; along with the battery. If you want to add a socket for an external plug-pack adaptor, follow the wiring diagrams given in project one.

## what to do next

It is very easy to add a second DICE circuit for games such as Backgammon, Monopoly, etc, where two dice are normally thrown at one time.

Of course, we could simply build a second dice, identical to the first, and press both buttons at one time. But this is inconvenient.

Our method of mounting the second dice avoids the second push button and, indeed, a few other components by 'sharing' some of the functions between the two dice.

Obviously, we cannot share the oscillator components or the counter, as we would simply get a duplicate reading between the two dice. So two individual oscillators and counters are provided, giving two completely random numbers. (Because of the 'tolerance' of components, the two oscillators will run at different speeds, even though we use components of nominally the same value).

To build the dual dice, you will need to build two kits. The first is exactly as per the instructions above (you could use your single dice if you wish). The second is virtually identical – but leave out D1, C2 and C3, as well as the wires to the switch and battery.

Where shown in figure 5, link the two boards with short lengths (about 30mm or so) of hook-up wire. These links should come from the component side of the second board, to the copper track side of the first board. It is fairly easy to solder to the copper pads – just make sure that you don't solder across to another pad and short circuit it.

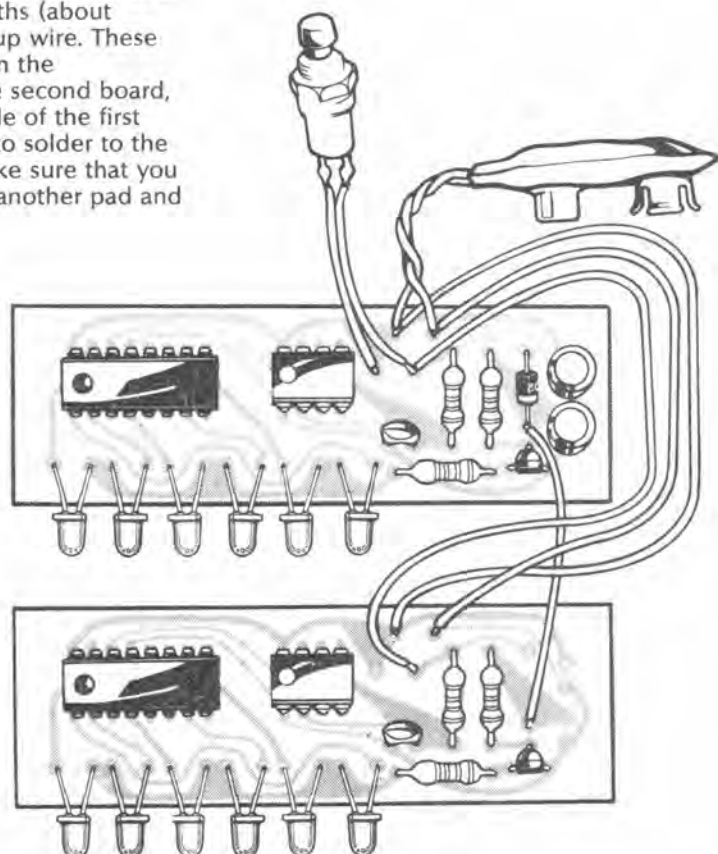
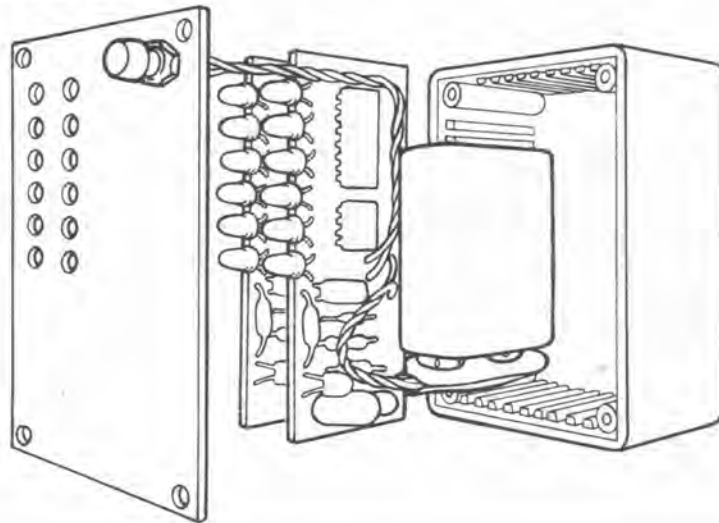

Figure 5: Wire the double LED Dice like this. As you can see, there are a number of components not needed on the second PCB.

# what to do next . . .continued

All that remains is to connect the battery and push the button. Both rows of LEDs should come on (dimly, as above), with one LED in each row glowing brightly when you release the button. Both LEDs should die out at about the same rate.

If you wish to mount the dual dice in a Zippy box, you will have to drill a second row of holes, as shown on the template. The second board mounts three slots behind the first to allow the LEDs to line up to the template. (You may need to lay over capacitor C1 to allow for this close spacing. This gives plenty of room for the battery to lie in front of board 1 when both boards are in the box).



## making a LED chaser

A very popular project to build is a 'chaser' – you've seen those displays in shops, around theatres, etc, where a row of globes lights up one after the other, giving the appearance of 'chasing' each other. By a very simple modification to the dice, we can make such a chaser from LEDs.

We are not going to need the LED turn-off circuitry, so this can be eliminated. Nor are we going to need the push button. All we require are the oscillator, counter and LEDs. Follow the alternative circuit (figure 7). If you wish, you can design a new printed circuit board using just these components or, if you wish, use the existing board and place wire links across the sections of the circuit we do not require.

The LEDs are best arranged in a circle or rectangle – so that the sequence is not broken when the first LED comes on immediately after the last LED has gone out. A further refinement of the circuit is to run a second set of LEDs in the circle, so you get two lights chasing each other around. Figure 9 shows how to do this.

Figure 7: The simplified circuit for the LED chaser (or for electronic jewellery below). The speed is slowed down significantly by changing C1 to a 3.3uF electrolytic.

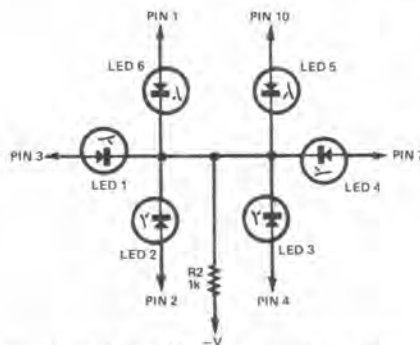
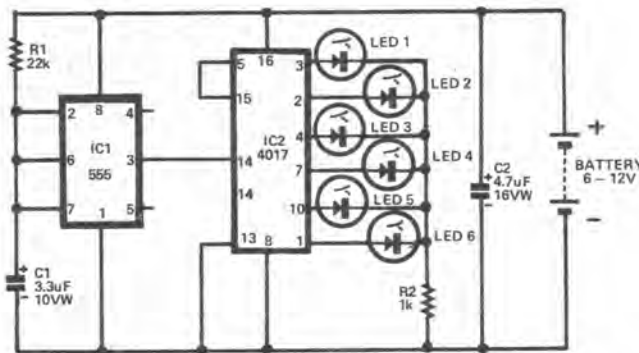

Figure 8: with the LEDs arranged in a ring the light appears to chase itself around the ring. This circuit is the same as that above; re-arranged to form a circle or rectangle.

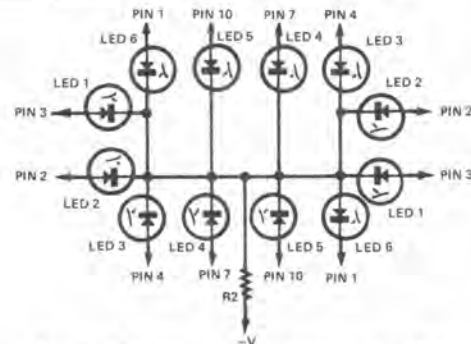

Figure 9: Adding a second LED in parallel and arranging the LEDs as shown gives two LEDs chasing each other around the ring. R2 might need reducing slightly if the LEDs are not bright enough (say 560 ohms).

## making electronic jewellery

Because the circuit operates from a wide voltage range (CMOS IC's are much more tolerant to voltage variations than other IC's, even though they are more 'fragile') it lends itself very well to another type of electronic jewellery. Instead of having a single LED (or two LEDs) flashing (as in project one) we can have up to ten LEDs flashing with this circuit.

In 'how it works', we mentioned that the IC can count to ten; in the dice circuit we make the circuit re-set on the seventh count by connecting the

'6' output to the re-set input.

Any of the outputs can be connected to the re-set input to make the circuit re-set; thus you can choose the number of LEDs you have flashing. And you can choose whether you have an even flash rate, by putting LEDs in each output, or a jumpy output, by missing out certain LEDs. The opportunity for experiments with this circuit are endless. Just remember that pin 15 is the re-set, pins 1-7 and 9-11 are the outputs (though they are not in numerical order).

You can slow the circuit down significantly by increasing either R1 or C1 (the converse is also true).

As far as a supply for the electronic jewellery is concerned, you should get a number of ideas from project one, where we covered this topic in some depth. As we mentioned, the circuit operates from a wide voltage range – you will probably find it works down to 3 volts or so; however, you might have to reduce R2 to a much lower value to allow the LEDs to glow bright enough at very low voltages. Try it first, and reduce as necessary.

# project number six

## Monophonic Organ

You've heard the magnificent tone of electronic organs: here's the Fun Way to build your own. It's economical and simple to play: you just move a 'stylus' (made from an old pen) across the copper tracks of the PCB. The organ covers a full two octave range, and even has 'vibrato' for extra realism.

Rolf Harris used an organ just like this when he started his career many years ago. Could this be the start of a career for you???

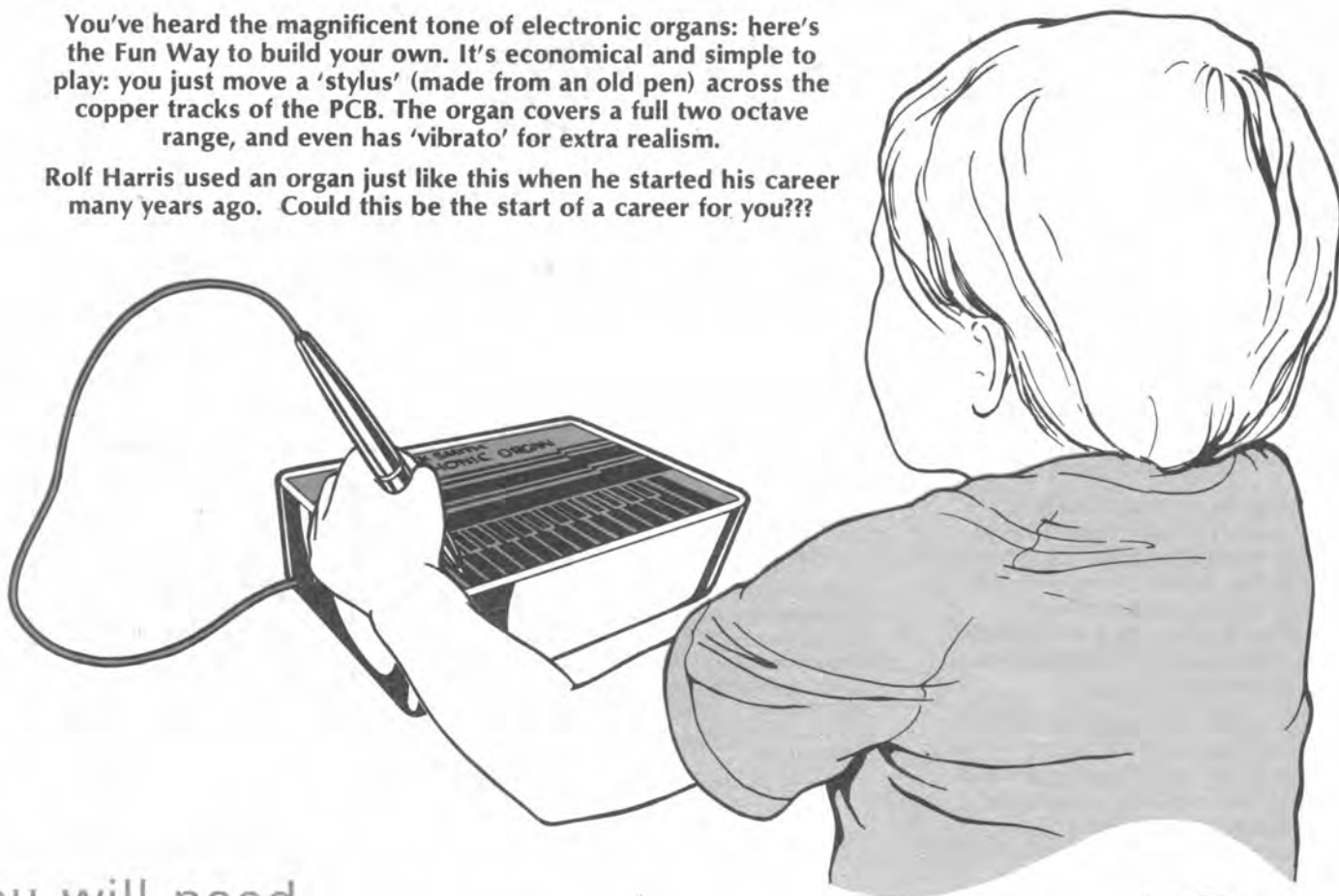

you will need  
these components

### Resistors

R1	100 ohms	R16	18k ohms
R2	150k ohms	R17	15k ohms
R3	8.2k ohms	R18	22k ohms
R4	8.2k ohms	R19	18k ohms
R5	8.2k ohms	R20	22k ohms
R6	10k ohms	R21	22k ohms
R7	10k ohms	R22	22k ohms
R8	10k ohms	R23	27k ohms
R9	10k ohms	R24	27k ohms
R10	12k ohms	R25	27k ohms
R11	15k ohms	R26	27k ohms
R12	15k ohms	R27	8.2k ohms
R13	12k ohms	R28	2.2k ohms
R14	15k ohms	R29	6.8k ohms
R15	15k ohms	R30	68k ohms
RV1	5k ohms trimming potentiometer		

### Capacitors

C1	.0047uF polyester (greencap)
C2	100uF 16V electrolytic RB
C3	100uF 16V electrolytic RB
C4	1uF tantalum or electrolytic
C5	.001uF polyester (greencap)
C6	220uF 16V electrolytic RB

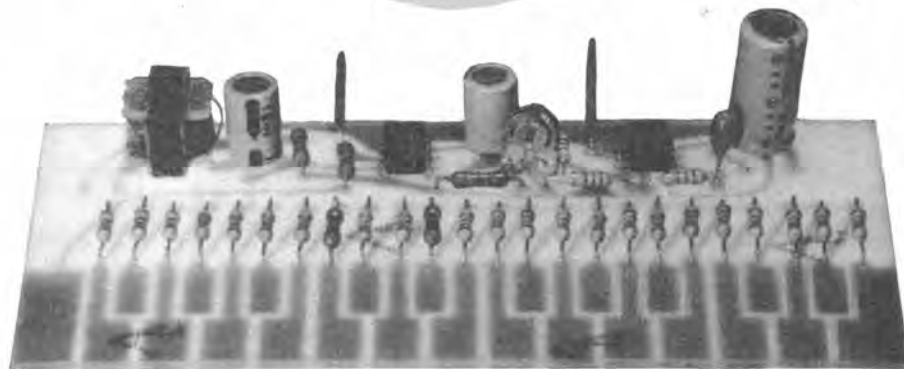

Figure 1

### Semiconductor Devices

IC1	555 timer integrated circuit
IC2	555 timer integrated circuit

### Miscellaneous

T1 1k ohm to 8 ohm audio transformer  
8 ohm loudspeaker  
Battery snap, solder, hook-up wire  
You will also require a 9 volt transistor battery (not normally supplied with a kit) or some other 9 volt DC power supply and a suitable mounting board or printed circuit board of correct design (DSFW2 K-2626 **Monophonic Organ** kit contains the correct PCB).



# putting it together

- (1) If you have purchased a kit (Dick Smith Cat K-2626 or similar), check off the components against the list to make sure they are all there and are the correct types and values.
- (2) If you have not purchased a kit, you will need to obtain the components listed and either make a printed circuit board using the component position drawing as a guide, or use perforated or tracked board.
- (3) Mount the components as shown in the component position drawing. Place and solder the resistors and capacitors first, taking care to ensure that you have C2, C3, C4 and C6 the correct way around as they are polarised. If your kit contains horizontal capacitors instead of the vertical types, simply mount the capacitor vertically and run the upper lead down the side of the capacitor to the correct pad on the PCB. Check that all components are positioned neatly and 'dressed' properly before soldering them in.
- (4) Place and solder T1, the 1k to 8 ohm audio transformer, taking care that it is correctly oriented. The 1k ohm side has three leads, and the 8 ohm side two. We don't use the centre lead on the 1k side, but it is handy for identification. Simply bend it up out of the way.
- (5) Now the 555 timer integrated circuits are inserted. Even if you've soldered IC's in other projects, care is still necessary. Treat each IC individually: that is, finish soldering one in before moving on to the next. Insert the IC into the holes on the PCB (make very sure it is the correct way around), and push it hard down until it won't go in any further. You may find that the rows of pins have to be bent outwards or inwards to make them fit. Before soldering, check once again that the indentation on the IC (near pin 1) lines up with the same as the dot marked on the drawing below. Solder the IC in very carefully, being very careful that you don't solder between tracks.
- (6) Repeat for the second IC, being just as careful.
- (7) Solder on the speaker leads to the pads on the PCB and to the speaker, then solder on the battery snap (and on/off switch if you are fitting one).
- (8) Until you make a stylus (see 'what to do next') connect a length of wire with a bared end to the pad where the stylus will connect.
- (9) Before connecting the battery, check your component positions and wiring. Connect the battery and try the wire 'stylus' on the keys: you should be greeted by a tone. Check the full range of the organ, then check the 'vibrato' switch for correct operation. You should hear a considerable difference.
- (10) See 'what to do next' for details of the pcb mounting and stylus.

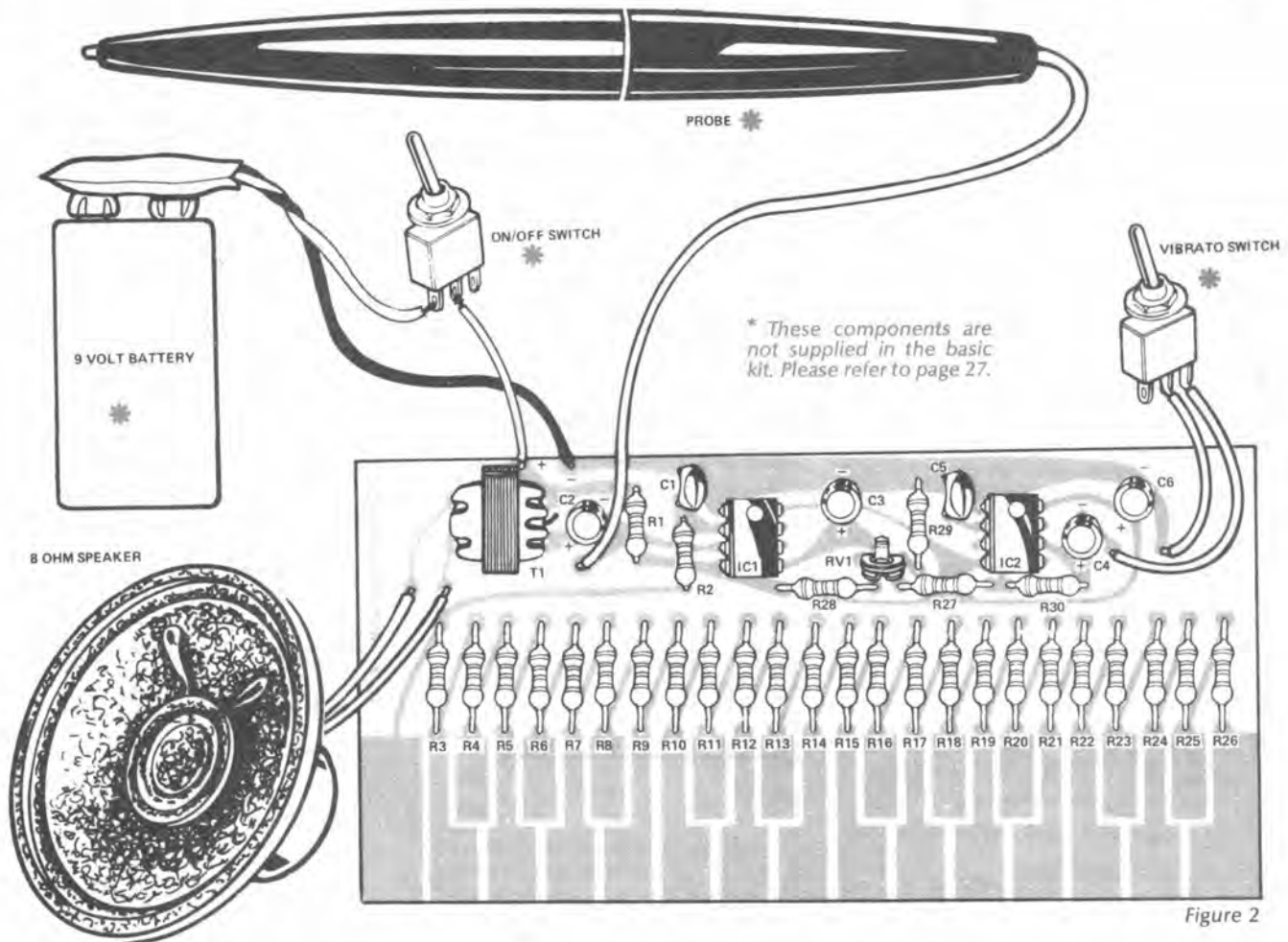

Figure 2

# what to do next

The Organ PCB does not slot into a Zippy box like other projects; instead it is mounted up-side down, as the lid of the box. In this way, the copper tracks are exposed to form the 'keyboard'.

Because of this, the soldered joints are also exposed. These may look a little rough, so the label has been designed to cover the soldered area of the PCB, leaving the keys. You might find it a little difficult to glue the label over the soldered area: if so, first glue on some 'foam rubber' as shown in the drawing.

You might also like to add a socket for external power. Wire this as shown in figure 4.

This circuit is fairly economical on batteries, however, this is at the expense of volume. If you want more volume and aren't too concerned about battery drain, T1 can be replaced with an 18 ohm resistor, and the speaker placed in series (as shown in figure 6). This might change the tone of the organ a little, too.

If you want to use the organ with an external amplifier, output can be taken from each side of the transformer primary. If this is to be a permanent arrangement, a 1k resistor can be connected in place of T1 primary, as shown in figure 7. If there are problems connecting the supply rails together, include a small capacitor (say 1uF or so) in series with each lead to isolate the circuits from each other.

## Making a 'stylus'

There are many ways of making a stylus: the easiest way is to simply solder the end of a piece of hook-up wire so it is rigid, and use this on the keys. However, this is a little difficult to play with!

A far more satisfactory method is to make a stylus using the barrel of an old ball-point pen, a nail and some glue. Simply solder the nail to a length of hook-up wire (copper nails are easiest to solder to), and pass the nail down the barrel until its point just emerges. Glue in this position with 'Araldite' or similar.

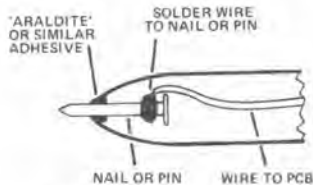
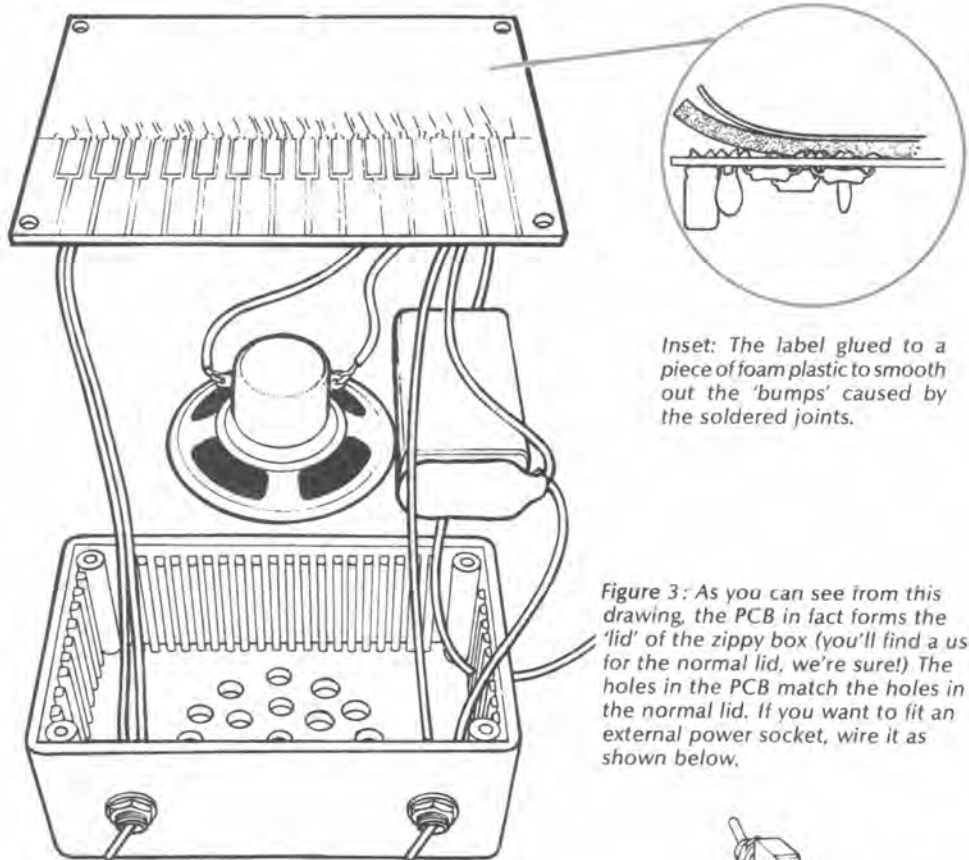

Figure 5: Detail of the 'stylus' point. You can make this from any type of plastic barrel; we used an old ball-point pen and a copper nail the same size as the hole in the end of the barrel.



Inset: The label glued to a piece of foam plastic to smooth out the 'bumps' caused by the soldered joints.

Figure 3: As you can see from this drawing, the PCB in fact forms the 'lid' of the zippy box (you'll find a use for the normal lid, we're sure!) The holes in the PCB match the holes in the normal lid. If you want to fit an external power socket, wire it as shown below.

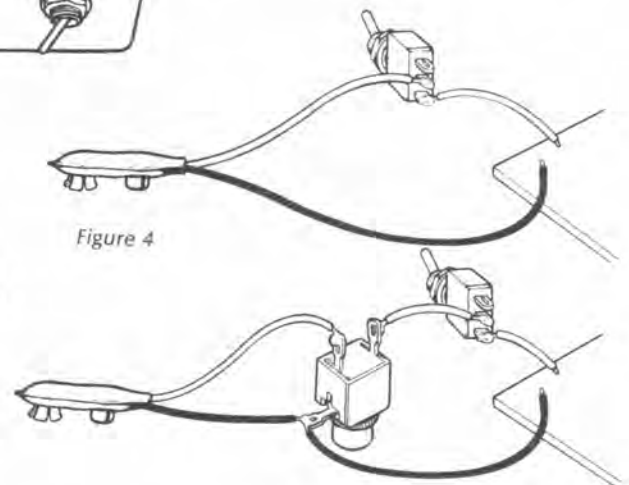

Figure 4: This diagram shows how to add an external power socket (standard 3.5mm type). The drawing on top shows the power switch only, the bottom drawing how the socket is interposed between the battery snap and the switch. Wiring in this manner will allow the on/off switch to function normally.

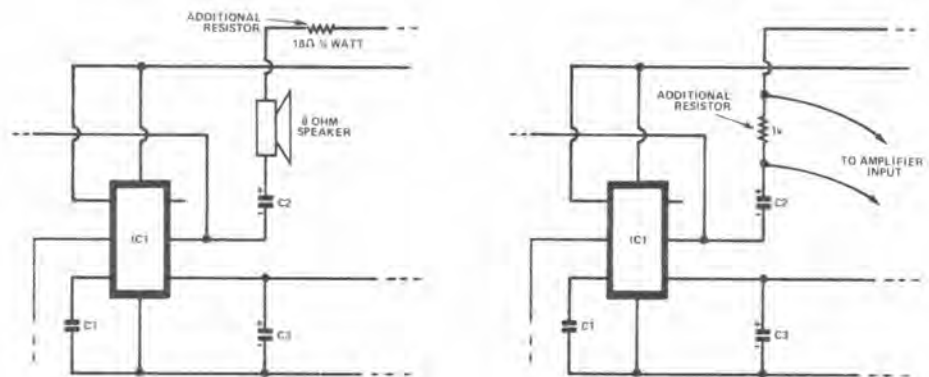

Figure 6: This circuit is pretty rough on a 9V battery, but will give you increased volume from the speaker. The extra resistor can be fitted on the pcb; use some of the pads which would have held the transformer connections (take care!).

Figure 7: Permanent connection to an external amplifier. The lower of the two 'flying' leads connects to the amplifier 'earth', the upper to the signal input.

# how it works

IC1 is an oscillator which will operate over a wide range of frequencies, depending on the 'time constant' of the R/C network composed of C1 and the resistor string R2 to R26. The resistance is selected by the stylus touching one of the 'note' pads to which the resistor string is connected. These resistors have been chosen and arranged to give note spacings as close as possible to the musical scale.

The output of IC1 is close to a square wave. The current causing this passes through the primary of T1, which induces a similar current in the secondary. A speaker converts this square wave to sound.

RV1 can change the overall pitch of the oscillator to account for minor variations in components.

The full supply voltage is connected to the output transformer for maximum volume, but a lower voltage is used on the rest of the circuit. C6 acts to smooth out the supply so that load variations do not alter the pitch.

This is called 'decoupling', and is used very often in electronic circuits,

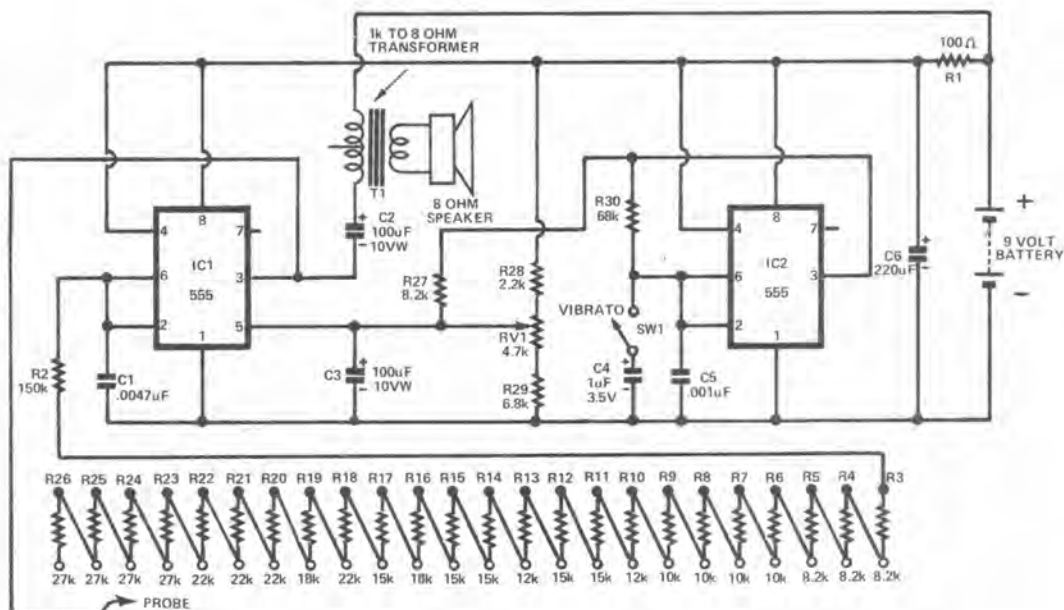

Provision is also made for a 'vibrato' circuit which modulates the main oscillator, giving the mellow tone associated with electronic organs. The vibrato oscillator runs all the time, but a switch changes its frequency from around 5kHz (which doesn't have any effect on the main oscillator) to around 5Hz (which makes the main oscillator output 'vibrate' over a small range). This is done so the switching in

and out of the vibrato circuit does not change the load and vary the pitch.

R30 can be adjusted up or down to give changes in the vibrato speed, if required.

The basic organ covers a range of two octaves, from 'C' (nominally 262Hz) to C (1047Hz), with 12 notes per octave, including sharps and flats.

## Thomas Alva Edison (1847 - 1931)

Born in Ohio U.S.A. Edison attended school for only 3 months. Despite this, he was a natural tinkerer. From the age of 12, working as a newsboy by day he would experiment in his spare time with electrical and mechanical apparatus.

He then was taught telegraphy, however, he was not one to be happy pounding away at the key. He was an experimenter at heart. While working in this profession, he made his first important invention – a telegraphic repeater device. This device enabled a message to be repeated over a second line without the presence of an operator.

Edison invented and refined numerous other telegraphic appliances some of which earned him the enormous sum (then) of \$40,000. This money went towards establishing his own laboratory in 1876.

Virtually from day one inventions started to pour out thick and fast. First there were more telegraphic inventions then the carbon telephone transmitter (microphone). This microphone is still essentially the same unit that is fitted in almost every modern telephone in the world today.

In 1877 Edison announced the invention of the phonograph – or 'record player' as we know it. In the original phonograph, the sound was recorded on a cylinder covered with

tinfoil. He later refined the invention by using a flat disc – similar to the 'records' that we know today.

Edison's most important invention, however, was the electric light bulb. It also took him the longest time to perfect. It was a tremendous success, however, and it dominated his remarkable career for some time. He became involved in further improvement of the bulbs and developing the electricity generating and distributing machines necessary for them to be used on a large scale.

During this period, Edison tried introducing a metal electrode inside the glass bulb. He then discovered that by placing a positive voltage on the electrode and a negative on the filament, he could get current to flow across the vacuum between the two.

Amazingly, this phenomenon was the great man's only fundamental scientific discovery! It became the basis of all electron tubes (valves) – and subsequently "electronics" – until the era of the transistor.

One might have expected Edison to pursue this discovery, but he did not. He patented it, called it the "Edison Effect" and left it at that. His intense involvement in electric illumination at the time was the probable reason for not going into the phenomenon further.



It was not until later that John Ambrose Fleming used the Edison effect as an efficient rectifier of high frequency alternating current, thereby inventing the vacuum diode.

Edison went on to invent many other devices which are common to us today. Among them are: the kinetoscope (motion pictures); A nickel-iron battery; Synchronised sound/picture movies; The mimeograph and many others.

# project number seven

## Pocket Transistor Radio

There are few thrills to compare with the surge of pride you'll feel when you turn on the first radio you've ever built . . . and it works!

Even though you can buy ready made transistor radios very cheaply these days – even cheaper than you can build one yourself – this special feeling of satisfaction makes it worthwhile building your own from a kit of parts.

Besides, building your own radio helps you understand what's going on more than any textbook can try to explain.

This little radio can be made small enough to fit into your pocket, yet it is sensitive enough to pick up stations which are quite distant.



## you will need these components

### Resistors:

- R1 1k ohms
- R2 100k ohms
- R3 100 ohms
- RV1 5k ohms pre-set potentiometer

### Capacitors:

- C1 .01uF disc ceramic
- C2 0.1uF disc ceramic
- C3 100uF 16V electrolytic
- C4 100uF 16V electrolytic
- CV1 60pF to 160pF variable tuning capacitor

### Semiconductor Devices:

- IC1 ZN414 integrated circuit
- TR1 DS548 or similar NPN transistor
- ZD1 6.8V 400mW or 1W Zener diode

### Miscellaneous:

- L1 Ferrite rod aerial
- One magnetic earpiece
- Solder, hook-up wire, etc

A suitable mounting board or printed circuit board of correct design (DSFW2 K-2627 Pocket Transistor Radio Kit contains the correct PCB).

You will also require a 9 volt battery and battery snap (not normally supplied with the kit). See text.



Figure 1

# putting it together

- (1) If you have purchased a kit (Dick Smith Cat. K-2627 or similar), check off the components against the above list to make sure they are all there and are the correct types and values.
- (2) If you have not purchased a kit you will need to obtain the components listed and either make a printed circuit board or use perforated strip board or similar, using the component position diagram as a guide.
- (3) Mount the components as shown in the component position drawing – resistors and capacitors first. Be careful to mount C3 and C4 the correct way around, with the negatives facing towards each other. Also take care with the Zener diode (ZD1). It mounts 'end on' to the PCB, with the cathode, the banded end towards the tuning capacitor.
- (4) The connections to the coils on the ferrite rod are probably the most important part of making this radio: the leads must be connected the right way around for optimum performance. Unfortunately, there is no guarantee that the colour coding of the coils will remain the same in years to come – if, in fact, there is any colour coding at all! So we will first explain which coloured wires go to which holes (assuming the ferrite rod aerial is the same as the one in the prototype) and then explain how to identify the coils if they are not colour coded. There are two individual coils on the aerial: the main coil, which forms the tuned circuit, and the aerial coil, which connects a long wire antenna to the circuit (if used). The coils must be connected to the right points on the pcb. The two wires for the antenna coil must not be mixed with the two wires from the larger coil. On the prototype, start of the main coil is coloured black, and the finish pink. These connect to the two pads directly behind the tuning capacitor, start to the left pad, finish to the right pad. The start of the aerial coil is coloured green, and the finish red. These solder to the pads to the left of the aerial; start to the left pad and finish to the right. The remaining pad in this area of the PCB is for connection of an

external long wire antenna, if desired.  
 Now! What if the coil you get has no colour coding? First, you must identify the two windings. The easiest way to do this is with a multimeter; find the two pairs of wires which indicate continuity. You should find there is about a 1:5 ratio of resistance (it could be higher). The lower resistance coil is the aerial coil, and the higher the main coil. It is not particularly important which way around the starts and finishes of each coil are connected, but because the wires are so similar on each coil, care must be taken. To be sure, a loose knot can be tied in the start and finish of one of the two coils for easier identification.

The ferrite rod aerial is secured to the PCB by means of half a loop of tinned copper wire, pulled tightly over the rod and held in position by soldering to two pads underneath. Take care not to make a complete turn of wire: this constitutes a 'shorted turn' and seriously impedes the operation of the radio.

- (5) You will notice when assembling the PCB that only two of the three leads of the variable capacitor are used. These are probably designated 'G' and 'A'. The capacitor may be attached to the PCB itself, or mounted on a box with wires connecting it to the PCB.
- (6) Solder in TR1 as shown on the drawing.

The ZN414 IC may be supplied in either plastic or metal pack, the pin connections are shown below. The metal pack is inserted as shown, the plastic pack has the flat towards the tuning capacitor.

- (7) Solder the earpiece and battery snap wires to the PCB, making sure that the red lead of the battery snap is connected to the positive terminal (via on/off switch, if you are fitting one).
- (8) Clip off excess leads, making sure that all of the soldered connections are properly made.
- (9) Check all components to ensure correct polarity and position before connecting the battery.
- (10) The circuit should now be ready for use. Connect the battery first, then plug the earphone in. Slowly tune the variable capacitor until you pick up a station. If you cannot hear anything, try adjusting the pre-set potentiometer and/or orienting the PCB in a different direction. The ferrite rod should be at 90° to the transmitter for best results.
- (11) If you still cannot hear anything or the stations are particularly weak, it may be that the signal levels in your area are very low, and you need an external antenna. A pad is provided on the PCB for connection of an external antenna; read on to 'What to do next' for more details on antennas.

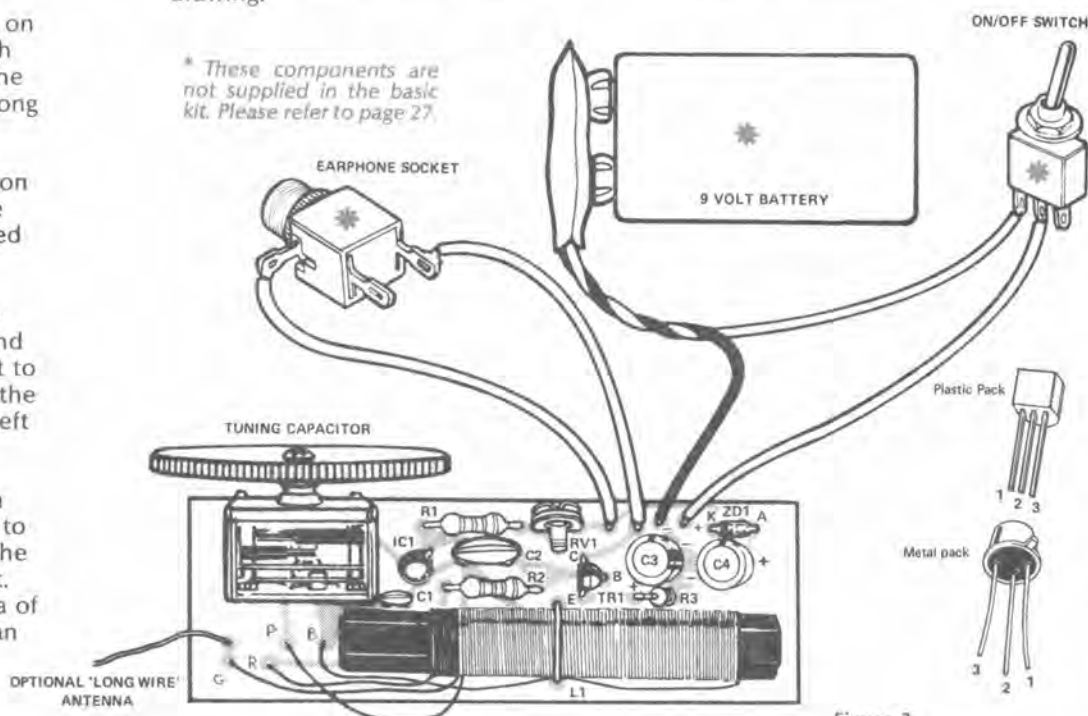

Figure 2

# how it works

This set uses a modern, powerful integrated circuit (IC), the ZN414. Inside the tiny package are 10 transistors and many other components!

In fact, inside the ZN414 there are four stages of radio frequency amplification, so that by adding a few components we have a complete 'tuned radio frequency' or TRF type AM radio tuner. This simply means that the incoming radio signals are tuned and amplified at their existing frequencies, instead of being shifted down in frequency first (the 'superheterodyne' principle).

The coil on the ferrite rod antenna and the variable capacitor between them make up a 'tuned circuit'. The tuned circuit is a very selective filter: it acts as a short circuit to most of the radio frequency current received by the ferrite antenna, but it allows one particular frequency through unhindered. The frequency is selectable over a certain range by adjusting the tuning capacitor.

The signal is then fed into the integrated circuit, where it is amplified and then detected or demodulated (just like a diode detector in a crystal set). The resulting signal at pin 1, the output, is like that from a diode detector. C2 filters out the RF component of the signal, leaving a clean audio signal.

An interesting feature of this circuit is the automatic gain control (AGC) which is achieved by 'feeding back' a DC component of the voltage across C2 to the input of the IC. This lets the IC sense when output is low and adjust its gain to compensate – and vice versa.

The amount of gain control is varied by RV1, the 5k variable potentiometer, which also varies the audio level and consequently the volume.

TR1, an NPN transistor, is used to present the IC with a high impedance load, so we are able to use a cheap, readily available magnetic earpiece to convert the signal into sound.

The supply for this circuit is a little unusual. The ZN414 IC requires a low voltage: nominally 2 volts or less. Of course, this can be obtained with an ordinary 1½ volt battery, but to connect to a single 1½ volt battery can be something of a problem.

It is not considered wise to solder directly to the case of a battery, but if we use a battery holder, it ends up too large to fit into the smallest Zippy box. So much for our 'pocket' transistor radio!

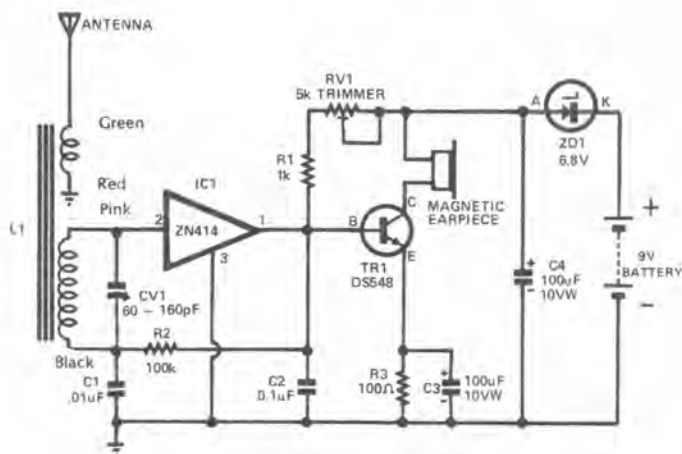

Figure 4

In order to overcome this problem, we decided to use a nine volt battery and battery snap which, though a tight fit, does make it into the small Zippy box along with the PCB, switch and socket. In order to give the IC the voltage it requires, we use a special component called a 'Zener diode'. The Zener is normally used as a voltage reference device, as it has quite a stable voltage drop across it. We make use of this voltage drop, by connecting the Zener

in series with the battery. The voltage drop across the Zener (in this case 6.8 volts) is subtracted from the battery voltage (9 volts) leaving us with approximately 2 volts: just what we want!

In order to smooth out any voltage fluctuations which might occur as the load changes (loud music passages, for example), an electrolytic capacitor is connected across the nominal 2 volt supply.

## what to do next

To make your pocket radio into a compact, robust unit you can mount the complete set, including the battery, on/off switch and earphone socket, in a small Zippy box (Dick Smith Cat H-2755 or similar).

Unlike other projects, we are not replacing the pre-set potentiometer with a larger type: there is no room for it in the box! We don't think this will be too much of a problem, however: once the level is set, most constructors will leave their pocket transistor radio at that level.

When mounting the PCB, battery,

socket and switch in the box, you will find there is not much room to spare! In fact, when the lid is screwed down, the end of the battery snap is forced over in order to fit. Don't worry: this is quite acceptable.

The attractive label supplied in the back of this book will give your set a really professional look. You will notice that the area around the tuning dial has been left blank, so you can mark the positions of your favourite radio stations on it. These will vary from area to area – so we've left them up to you.

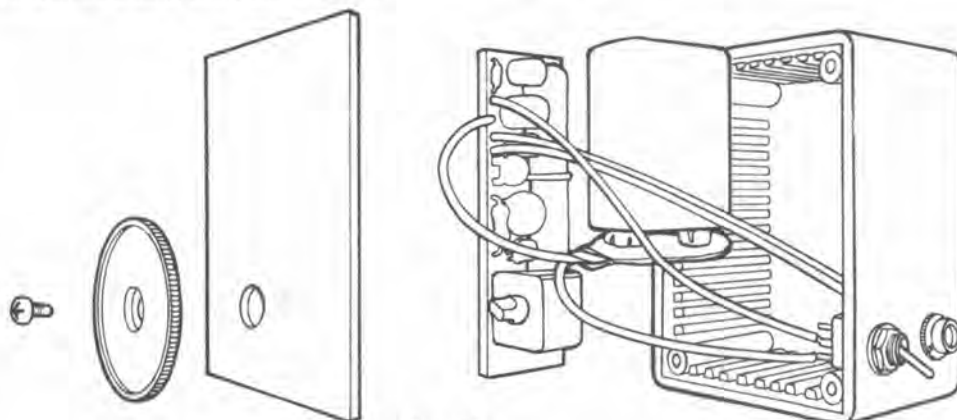

Figure 5

## what to do next ...continued

If you want to do some experimenting with this circuit, you should find it can be made to operate over a wide frequency range. The ZN414 IC is capable of operating from long wave (below the broadcast band) to short wave frequencies.

The 'tuned circuit' consisting of the aerial coil and tuning capacitor fixes the range of frequencies covered. The easiest way to change the range is to alter the number of turns on the aerial coil. Note that the larger coil is changed; the smaller coil is left intact.

A smaller number of turns on the coil will raise the frequency range covered; conversely additional turns will lower the frequency range. With a bit of experimentation and practice, you might be able to pick up shipping, aircraft beacons and, perhaps, the occasional amateur operator.

If you find the levels of signal you receive are too low, you might need an external aerial. The old 'rule of thumb' – as high and as long as possible – still applies. Keep your aerial well clear of any power lines, however.

If you want to make your transistor really tiny, there is nothing to stop you using miniature silver oxide 'button cells', such as are used in watches and hearing aids. To use one of these you would connect a link in place of ZD1.

The main problem with these batteries (and the reason we didn't use them), were the difficulties in connecting to them. If you can overcome these problems, your radio can be made very tiny indeed.

Whatever you do, don't try soldering direct to these cells; they have a nasty habit of actually blowing up when subjected to intense heat!

On the other hand, there is nothing to stop you using a larger Zippy box and an ordinary 1½ volt battery. Holders for most sizes of batteries are available.

## Marchese Guglielmo Marconi (1874 - 1937)

Born in Bologna, Italy, Marconi is generally regarded as the "Father of Radio". He was indeed the inventor of the first practical radio signalling system, although some people claim to have transmitted radio signals before him.

At the tender age of 16, Marconi became interested in the concept of 'Wireless Telegraphy'. At this time the overland telegraph was an important form of communication. The main drawback, of course, was the expensive network of telegraph wires that had to stretch across the countryside. This also virtually prevented international communication as well.

In 1896, in Pontecchio near Bologna, Marconi used grounded directional antennas to send telegraph signals through the air over a distance of about 2½ kilometres. He immediately went to Great Britain, patented his system and formed Marconi Wireless Telegraph Co. Ltd.

In 1899, he established communication across the English Channel between France and England.

Marconi's crowning achievement, however, probably did not occur until 1901. In that year he transmitted waves from Poldhu, Cornwall, England, to St Johns, Newfoundland, Canada. This achievement captured the public's imagination at the time.



The military aspects of his system were immediately recognised and the British and Italian navies adopted it. By 1907 the system had been refined to a point that a regular transatlantic wireless telegraphy service was established for public use.

At this point in time, Marconi's equipment worked without the aid of any kind of amplifier whatsoever! That was to come later.

Marconi was awarded the Nobel prize (jointly) for Physics in 1909.

His later years were spent researching short-wave and microwave transmissions.

Marconi, by the way, saw Morse code as the main reason for wireless telegraphy. He did not see the need for voice transmission! Unbelievable.

## Edwin Howard Armstrong (1890 - 1954)

Probably one of the greatest unsung heroes of radio. He made many of the most significant contributions to electronics, yet is not a well known individual.

He was born in New York City and was educated at the famous Columbia University. At 22, he demonstrated the "Regenerative Circuit". This circuit coupled a small part of the output signal back into the input. In this way he effectively increased the amplification of the triode valve – still in its infancy. It was an unstable type of design as too much feedback caused the circuit to oscillate. As a matter-of-fact the oscillator circuit was invented at about the same time and honours for this were shared by many – including Armstrong.

During World War I, Armstrong served in the U.S. Army in the Signal Corps. Whilst in this capacity he conceived and built the first Super-heterodyne Radio Receiver. This amazing circuit is found in virtually every radio, radar and TV set manufactured in the world. – (See Circuit Milestones: The Superheterodyne, p. 35).

Armstrong went on to improve the regenerative circuit in the form of the "Super Regenerative" receiver. Whilst this circuit did

not have the commercial impact of the Super-heterodyne, it was very popular with Amateur constructors – even today. From time to time you will see projects in Electronics Hobby magazines describing "Super-Regen" sets – especially for receiving short wave.

But Armstrong's greatest innovation was yet to come. He perfected FM radio! Whilst the theoretical possibility of FM (Frequency Modulation) was known since the early '20's, most people believed it to have no practical advantage over AM (Amplitude Modulation). This narrow view was refuted by Armstrong who had a strong instinctive nature when it came to the physics of electronics.

In 1935, Armstrong set up a spectacular demonstration of the advantages of FM over AM. He transmitted an AM and an FM signal side by side from New York City to the adjoining state of New Jersey, where his laboratory was situated. You guessed it – the FM signal was loud and clear, but the AM signal could not be heard for background noise.

Today, TV sound, most two-way radio and high quality broadcasting is FM.

We have a lot to thank Edwin Armstrong for when we enjoy the equipment he helped invent.

# project number eight

## Touch Switch

You're lying in bed at night and you hear a strange noise. You sit up, and reach out for the bedlamp switch. In the darkness, all you succeed in doing is knocking the lamp off the table, blowing the bulb. You slide back under the blankets, trembling . . .

Wouldn't it be a lot easier if all you had to do was reach out in the general direction, knowing that just one touch would turn the lamp on?

You can do it with this ingenious touch switch.

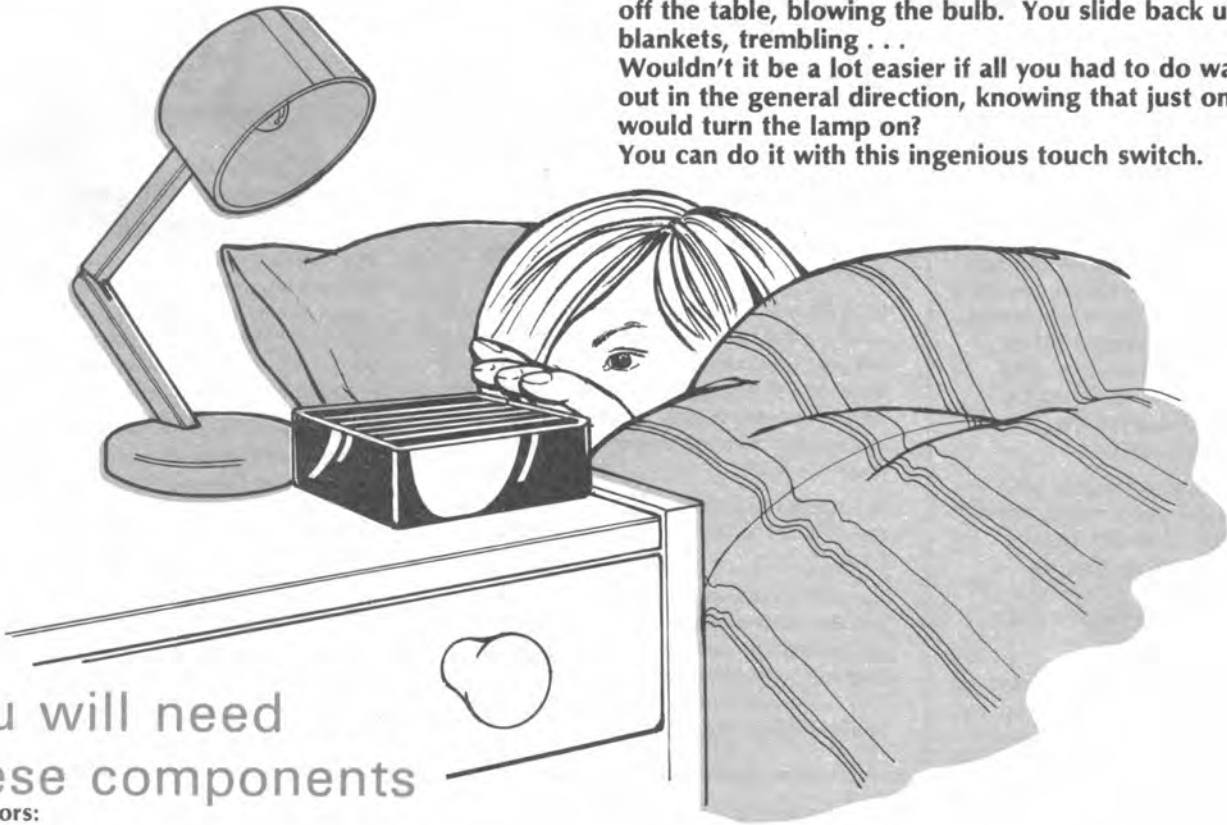

you will need  
these components

### Resistors:

- R1 10k ohms
- R2 22k ohms
- R3 390 ohms
- R4 6.8k ohms
- R5 120 ohms

### Capacitors:

- C1 10uF 16V electrolytic

### Semiconductor Devices:

- TR1 NPN type DS548 or similar transistor
- TR2 as above
- TR3 as above
- TR4 as above
- IC1 SN7473 integrated circuit
- D1 1N914 diode
- D2 1N914 diode

### Miscellaneous:

- RLY1 9-12 volt relay with changeover contacts. Battery snap, solder, hook-up wire

You will also require a 9 volt transistor battery (not normally supplied with a kit) or some other 9 volt DC power supply.

A suitable mounting board or printed circuit board to correct design (DSFW2 K-2628 Touch Switch Kit contains the correct board.)

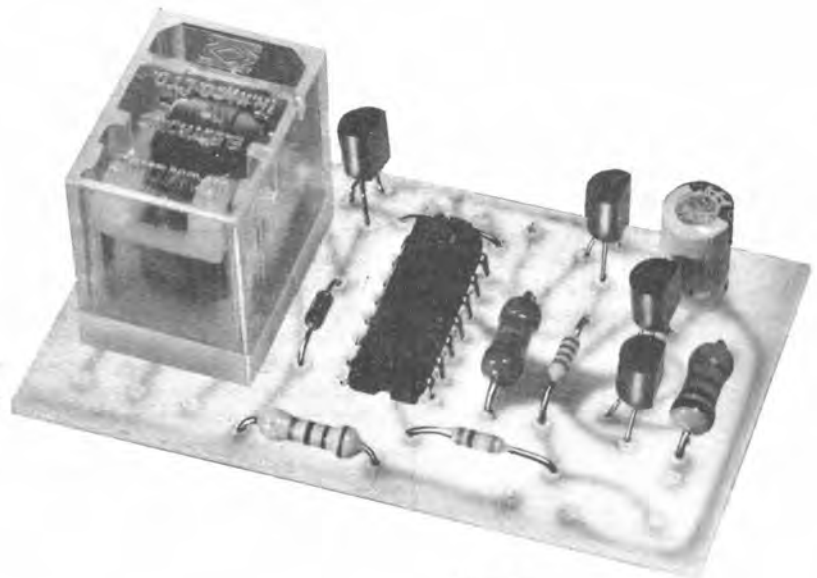

Figure 1



# putting it together

- (1) If you have purchased a kit (Dick Smith Cat. K-2628 or similar), check off the components against the above list to make sure they are all there and are the correct types and values.
- (2) If you have not purchased a kit, you will need to obtain the components listed and either make a printed circuit board using the component drawing as a guide, or use a perforated strip or tracked board.
- (3) Mount the components as shown in the component drawing – resistors and capacitors first taking care to place C1 around the right way, (don't forget 'dress'). Then solder these in.
- (4) Position the relay and solder it in. The fifth pin should make it easy to place it in the correct way around, although you must of course take care.
- (5) Position the four NPN transistors taking great care to ensure the correct polarity. Then solder them in carefully, using a heatsink clip to prevent damage from heat.
- (6) Now for the integrated circuit! If you have never soldered one before, take your time and take great care. The pins are very close together and consequently it is very easy to apply heat for too long to the device. Make sure you have the IC the right way around. The notch is between pin 1 and pin 14. You may find it much easier and more economical in the long run to use an IC socket or Molex pins on the board itself and simply plug the IC in later, when soldering is complete.
- (7) Solder on the three wires for the mode switch, and solder on the mode switch. The terminals on the switch are oriented the same as the pads on the PCB. If you want one mode only (unswitched), a wire link can be substituted for the switch and wires. Simply connect the centre and left pad (of the three 'switch' pads) together for 'on when touched' operation; the centre and right pin for touch on/touch off operation.
- (8) Solder the battery snap leads on in the correct polarity – red to positive (+), black to negative (-).

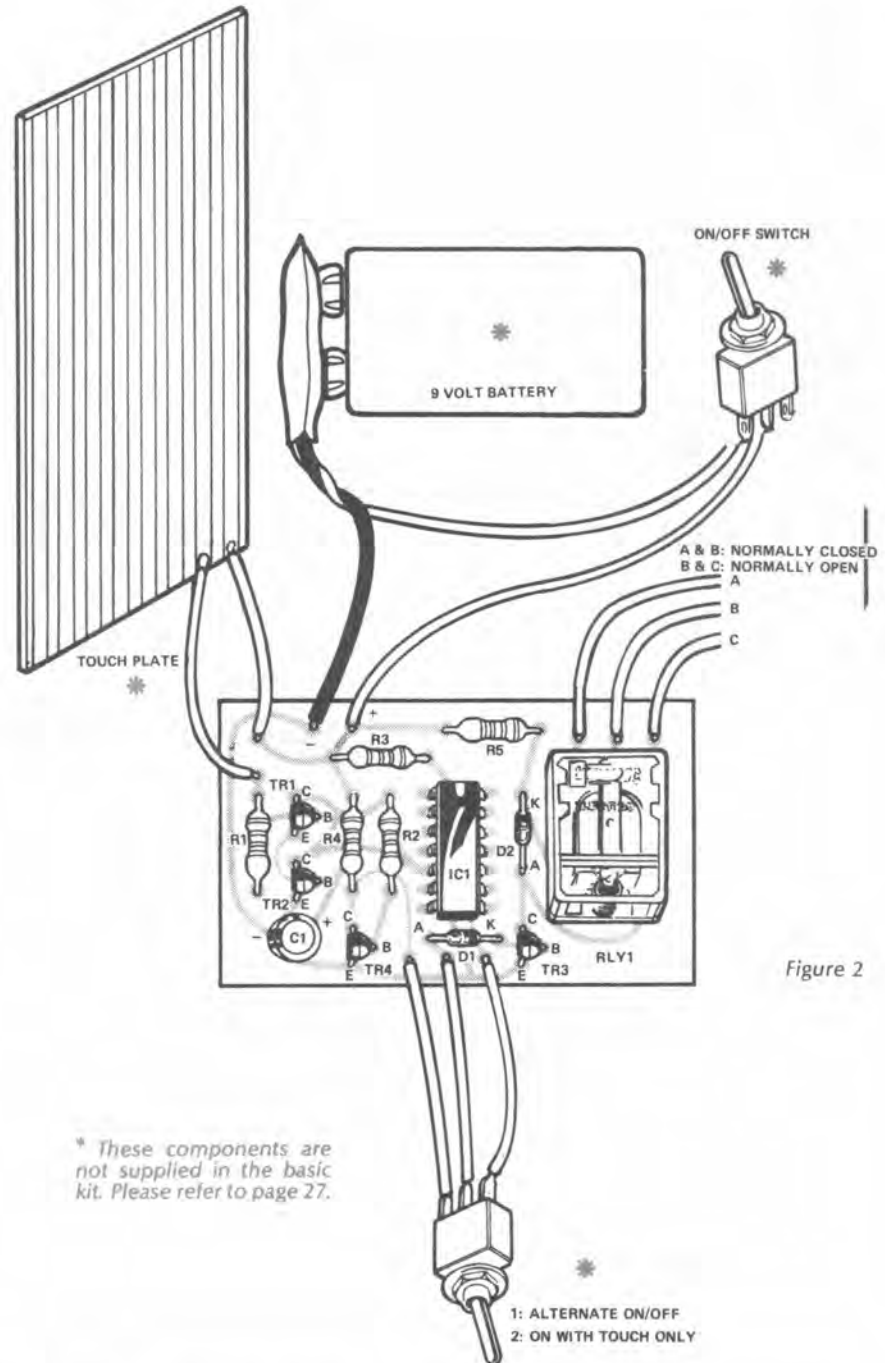

Figure 2

- (9) Clip off excess wire neatly, making sure that all of the soldered connections are properly made.
- (10) Check all components to ensure correct polarity and position before connecting the battery.
- (11) Connect the battery and touch your finger to the contact points. The relay should operate with a 'click' and, depending on the mode of operation you have selected, either change back again when you have removed your finger, or stay on in that position, only to change when you touch it again.
- (12) Change the switch to the opposite position to check the operation of both modes. Once you're satisfied that it works properly, turn to '**What to do next**' for some exciting applications for this clever little device.

## what to do next

As you can see from the drawing, we haven't supplied the usual label for the touch switch. This is because the aluminium lid of the box has been replaced with a touch pad made from a piece of 'perforated strip board'.

Perforated strip board is a special type of printed circuit board, which has parallel rows of conductors etched into it, which are drilled at small intervals for mounting components. This board makes a very handy touch pad: all you have to do is link every alternate track together (see figure 4) and connect them to the touch switch.

No matter where you touch the board, your finger must connect at least two (and possibly more) tracks together. So the switch actuates.

The strip board is normally supplied in a larger piece (such as Dick Smith Cat. H-5612). You can cut out a piece to size, and use the remainder for building various other projects. It is always handy stuff to have around!

The lid of the H-2753 Zippy box measures 60 x 124mm: cut your touch pad the same size, and drill holes in the corners to match the aluminium lid. If you find the screws short two or more tracks out when inserted, carefully scrape away the copper around the holes with a sharp knife.

Now: how about putting it to use!

The illustration at the commencement of this project shows the touch switch connected to a bedside lamp. This is a great idea! You can use a low voltage lamp if you wish, and run it from the same plug-pack that operates the touch switch itself.

Simply connect the relay contacts as if they were a switch in the positive supply between the plug-pack and the lamp.

Or, for the more adventurous, the touch switch relay could be used to switch another relay, capable of controlling 240 volts. This could then be used to switch a normal bedlamp directly. You'll find some tips on using the project relay to control mains devices in 'Using Relays' elsewhere in this book. Once again, please be careful: if you don't know what to do, don't do it. The 240V mains is dangerous: ask someone who knows what they are doing to give you a hand. We want you around to build some more projects!

There are a lot of other hobby ideas you can come up with for the touch switch: use it anywhere you need a remotely controlled switch action.

By the way, this circuit can be used for

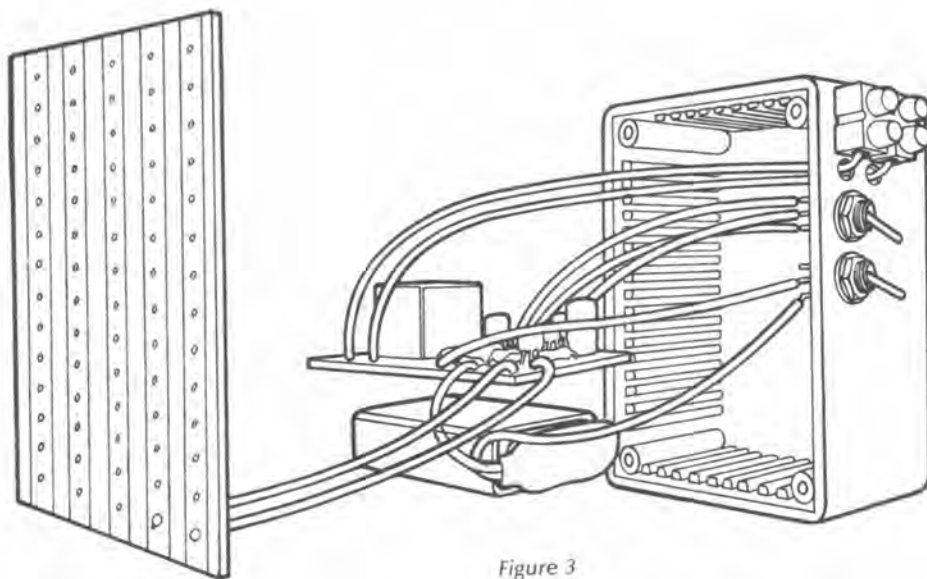

Figure 3

Figure 3: The PCB slots into the Zippy box sideways, with the battery underneath. As you can see, the front panel has been replaced by a touch pad the same size . . .

Figure 4 (right): And this is the touch pad (and how to wire the tracks). The touch pad is cut from a length of perforated strip board. It is most easily cut by scoring with a sharp knife, then snapping.

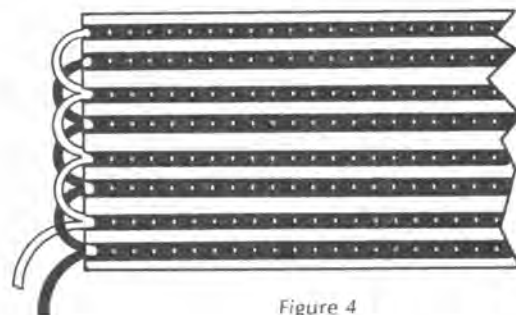

Figure 4

more than a touch switch: anything capable of passing a small current between the contacts of the touch pad will set it off. This circuit also makes a handy rain alarm (great for warning Mum that the washing has to come in!) It only takes one drop of water across the tracks to 'trip' the switch. Connect the touch switch relay to the siren or ding dong doorbell for a warning.

Used as a rain alarm, you might find that the touch switch will not turn 'off' again. This is because once wet, the base material used in the strip board has a low enough resistance to keep the contacts electrically bridged. The solution: spray the PCB with a water repellent (such as you would on clothes). It soaks into the PCB and stops it absorbing water.

You might find the same problem at times if very sweaty fingers are placed on the touch pad. The solution is the same.

Because the touch pad can be connected by any reasonable length of wire, there is nothing to stop you using the touch pad at some distance from the touch switch itself. For example, it could be used as a door bell push button.

## milestones in

Many of you who are reading this book have grown up in a decade which virtually saw the end of an electronic component called the "valve".

Valves, or Electron Tubes as they are more correctly known are still used today in specialised applications, however, these applications are diminishing.

As you probably know, the meaning of a valve usually refers to a device which will only operate in one direction. The air valve on a car tyre for example, will only let air in, not out. The same applies to a radio valve. They let electrons flow in one direction only.

Thomas Edison was the first person to discover this phenomenon, but how did he discover it?

As you know, Edison invented the electric (incandescent) light bulb. (If you **don't** know this, turn to page 51 and read more about him!)

# how it works

Normally the contacts of the touch pad are open circuited: that is, they are not connected to each other. However, when you touch them, your fingers act as a resistor and current passes from one pad, through your fingers, and to the other pad. This current then passes through R1 (a limiting resistor to prevent damage should the touch pad actually be short-circuited), and to the base of TR1.

TR1 and TR2 are connected as a 'Darlington Pair' – you will notice that their collectors are connected together, and that the emitter of TR1 is connected directly to TR2. This configuration is the equivalent of a single transistor, having very, very high gain – a tiny base current is all that is required to switch a fairly high current through the collector/emitter.

While the circuit is 'at rest' (that is, with nothing touching the pad), C1 is held charged via the internal circuitry of the IC. TR3 is also turned on, which allows current to flow through the collector/emitter.

What happens from here depends on the position of the switch. If it is in the lower position, TR4 is connected to TR3's collector via D1. Because TR3 is on, its collector voltage is low; TR4 therefore stays off.

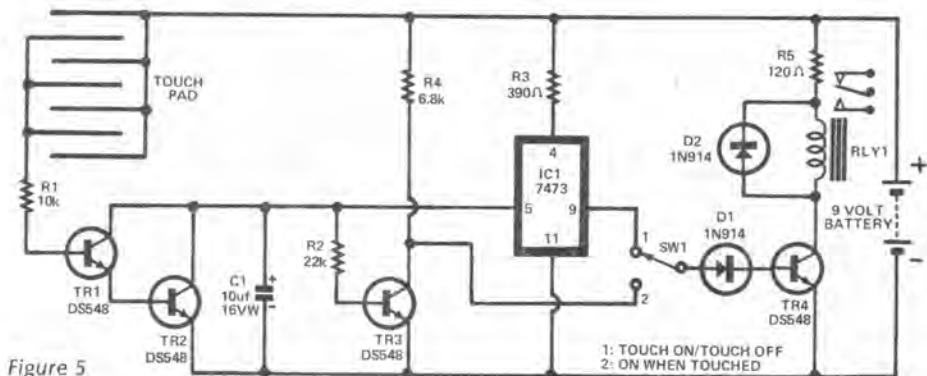

Figure 5

However, if the pad is touched, the Darlington pair conduct, turning TR3 off. TR4 turns on, pulling in the relay. If the fingers are taken off the touch pad, TR3 can turn back on again, turning off TR4. Thus the relay drops out.

So each time the pad is touched, the relay pulls in.

Now let's consider what happens with the switch in the upper position.

Obviously, the integrated circuit (IC1) is connected into the circuit. IC1 is a 'flip flop' IC, which is similar in many ways to the multivibrator we used in project one (although this is in IC form, of course!)

There is one basic difference: the flip flop does not oscillate of its own accord: it changes from one state to

the other (and back again) each time a triggering pulse is received at its input.

This triggering pulse occurs when TR3's collector voltage goes low – in other words, each time the pad is touched.

The first pulse might send the voltage at pin 9 from low (approximately 0.2 volts) to high (nearly 5 volts). The next pulse would send the voltage low again. The next high, and so on.

Each time the IC output goes high, TR4 turns on, pulling in the relay. Thus the flip-flop makes the touch switch alternate in action: each time the pad is touched, it changes state.

## electronics ... the development of the valve

It was a big deal at the time and being a natural tinkerer, he tried a few experiments. One of these experiments was to make up a special light bulb as shown in Fig.1. He was trying to improve the life of the fragile carbon filament in the bulb – he did not solve **that** problem in this case, but he noted a rather strange phenomenon.

When a positive voltage was applied on the electrode (with respect to the filament) current flowed from the filament to the electrode, right across the vacuum inside the glass bulb. It **did not** flow the other way, however.

Amazingly enough, he did not follow-up this discovery.

Over 20 years passed before the phenomenon was used by John Ambrose Fleming, an English associate of Edison. He realised that this phenomenon could be used to "rectify" radio signals – or any alternating current for that matter.

In this way it was used just like the diodes that we use in our Fun Way projects. In fact, electron tubes that do the job of rectifying are also called diodes.

But like other diodes, these early devices could not amplify either. Yet another electrode had to be introduced inside the glass envelope.

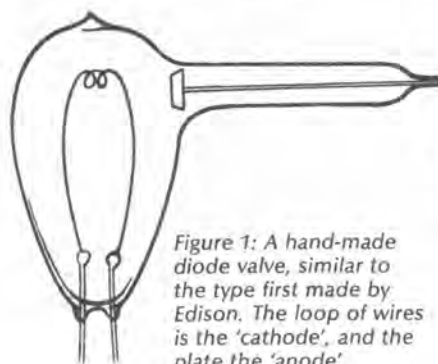

Figure 1: A hand-made diode valve, similar to the type first made by Edison. The loop of wires is the 'cathode', and the plate the 'anode'

This was done by an American, Lee De Forest, in 1906. De Forest inserted a wire 'grid' between the filament and the positive electrode (now called the "anode"). The grid was used to **control** the amount of electron flow between the filament and the anode. A small signal on the grid caused an identical but larger signal to appear at the anode. The amplifying valve was born!

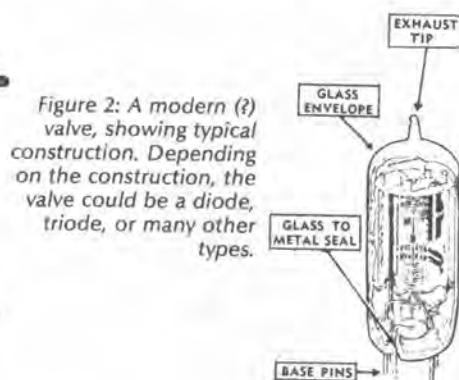

Figure 2: A modern (?) valve, showing typical construction. Depending on the construction, the valve could be a diode, triode, or many other types.

# project number nine

## A MOSQUITO REPELLER

It's a hot night and you're lying uncovered on your bed, trying to sleep and zzzzzzzing!!!!

You're wide awake and slapping about, trying to kill a mozzie!

Or you're out for a drive, and find a beautiful spot for a picnic. So it's out with the food and drink; you settle down and start to unwind. Then you start to scratch furiously at your arms, your face. You've been attacked by the natives who are after blood: yours!

What if you could just flick a switch, and go back to sleep, or back to enjoying yourself, safe in the knowledge that you won't be bothered again?

This ultrasonic mosquito repeller has been designed to enable you to do just that – anywhere you like!

University research has suggested that, during the time a female mosquito is incubating her eggs, she not only needs blood, but shuns all male mosquitos. In their misery, the males emit a special sound; but all this does is drive the females away!

As it is only pregnant females that bite you (they need blood for their eggs), all you need to do is carry around some male mosquitos and, in theory, you should be left alone. If you find it hard to carry male mosquitos around, try the mosquito repeller: it has been designed to simulate, as far as possible, the sound of the lonely male mosquito (in fact, a whole swarm of lonely males). In theory, then the female leaves you alone, and takes off for greener (redder?) pastures.

The university tests we mentioned have shown the mournful male emits a sound in the range 21 to 23kHz: far above the range of human hearing. In the laboratory, our mosquito repeller produced 22kHz: right in the middle of the range.

Whether your mosquito repeller works in the way intended depends on a number of factors: the appetite of the mosquitos in your area being one of them. Try it: you may be pleasantly surprised at the lack of mosquitos around your place.



# you will need these components

## Resistors:

R1 15k ohm  
R2 100 ohm  
R3 680 ohm

## Capacitors:

C1 .0022uF polyester (greencap)

## Semiconductor Devices:

TR1 Unijunction transistor type DS2646 or similar.  
TR2 NPN type DS548 transistor or similar.

## Miscellaneous:

T1 Audio transformer, 8 ohm to 1k ohm.  
One 8 ohm loudspeaker.  
Battery snap, solder, hook-up wire.

You will also require a 9 volt transistor battery (not normally supplied with a kit) or some other 9V DC power supply.

A suitable mounting board or printed circuit board of correct design (DSFW2 K-2629 Mosquito Repeller Kit contains the correct PCB).

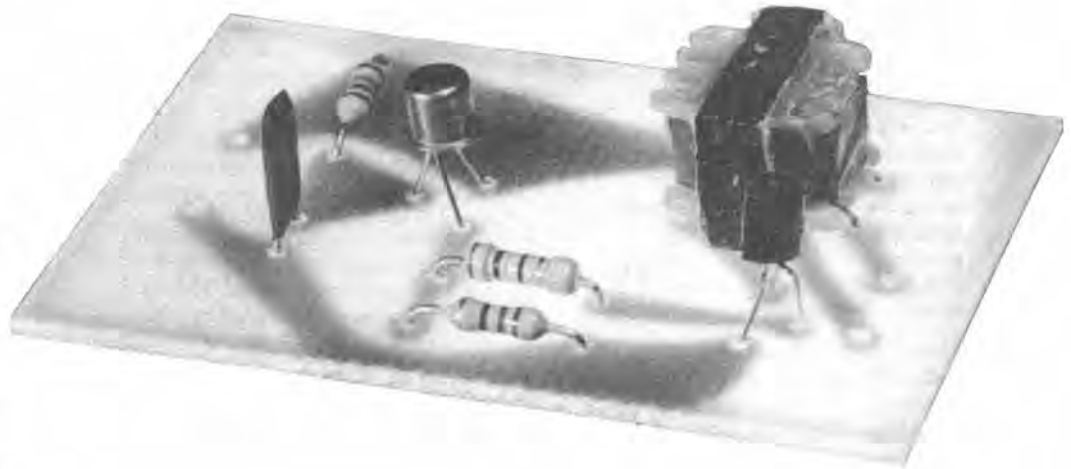

Figure 1

## how it works

This project uses a component which might be new to you: the unijunction transistor. Actually, the name is a bit misleading, as the unijunction is not a transistor at all: both the construction and operation of the device are quite different from the transistor.

The unijunction (abbreviation UJT) has two basic states: on and off. It is turned on by causing the voltage between the emitter (yes, emitter!) and base 1 to exceed the device's triggering voltage. If the voltage falls again, the unijunction turns off.

These characteristics make the unijunction ideal for use as an oscillator: the task it performs here.

When the battery is connected (or the switch is turned on if you have fitted one) the capacitor C1 charges via R1. As the capacitor charges, its voltage (and therefore the voltage across E/B1) rises until the point is reached where the unijunction 'fires'.

When it does, the resistance between both E/B1 and B1/B2 decrease to a low level. Therefore the capacitor is discharged through the unijunction, at the same time as the voltage at the junction of R2 & R3 rises to close to the supply voltage.

This sudden rise in voltage also raises the base voltage of TR2, turning it on.

A current flows through the primary of the transformer, which is transferred to the secondary. When this current flows through the speaker voice coil, the cone moves.

In normal circumstances, movement of the cone vibrates particles of air, and we hear these vibrations as sound. In this case, however, we don't.

Because the capacitor discharged when the unijunction fired, the unijunction turned off. The capacitor charges again, repeating the cycle over and over.

The frequency of the oscillator is determined by the 'time constant' of the R/C network, R1/C1. The values

have been chosen to produce a repetition rate of some 22,000 times per second: thus the speaker cone moves in and out 22,000 times per second (or 22kHz). This produces a sound far higher than we humans can normally hear – but it is exactly the right frequency to drive away those frenzied female mosquitos!

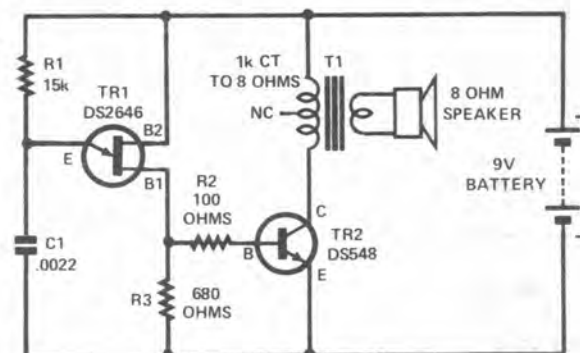

Figure 2

## putting it together

- (1) If you have purchased a kit (Dick Smith Cat K-2634 or similar) check off the components against the parts list to make sure they are all there and are the correct types and values.
- (2) If you have not purchased a kit you will need to obtain the components listed and either make a printed circuit board using the component position drawing as a guide, or use perforated strip board and the component position drawing to make a similar mounting board.
- (3) Mount the components as shown in the component position diagram – resistors and capacitors first. Use the accompanying diagram to make sure you orient the unijunction transistor the correct way.
- (4) Solder in these components and 'dress' the leads.
- (5) Next mount the transformer on the PCB. Note that one side has two legs, and one has three. The centre leg on this side must be removed or bent back before mounting the transformer.
- (6) Place and solder the only other semiconductor device: the NPN transistor.
- (7) Strip the insulation from the ends of the hook-up wire and the wires from the battery clip, twist the exposed strands and tin them as described in 'How to Solder'.
- (8) Solder the battery snap wires to the PC Board, ensuring that they are connected with the correct polarity, i.e., red wire to positive (+) and black wire to negative (-). Solder the wires to the

speaker and then to the correct pads on the PCB. These are not polarised.

- (9) Clip off all excess wire neatly, making sure that all of the soldered connections are properly made.
- (10) Check all components to ensure correct polarity and position before connecting the battery.
- (11) Connect the battery, but don't be disappointed if you hear nothing: sound above 20kHz (20,000 cycles per second) is usually inaudible to the human ear.
- (12) Demonstrate it to your friends, by pointing out that there are no mosquitos around whenever it is connected!

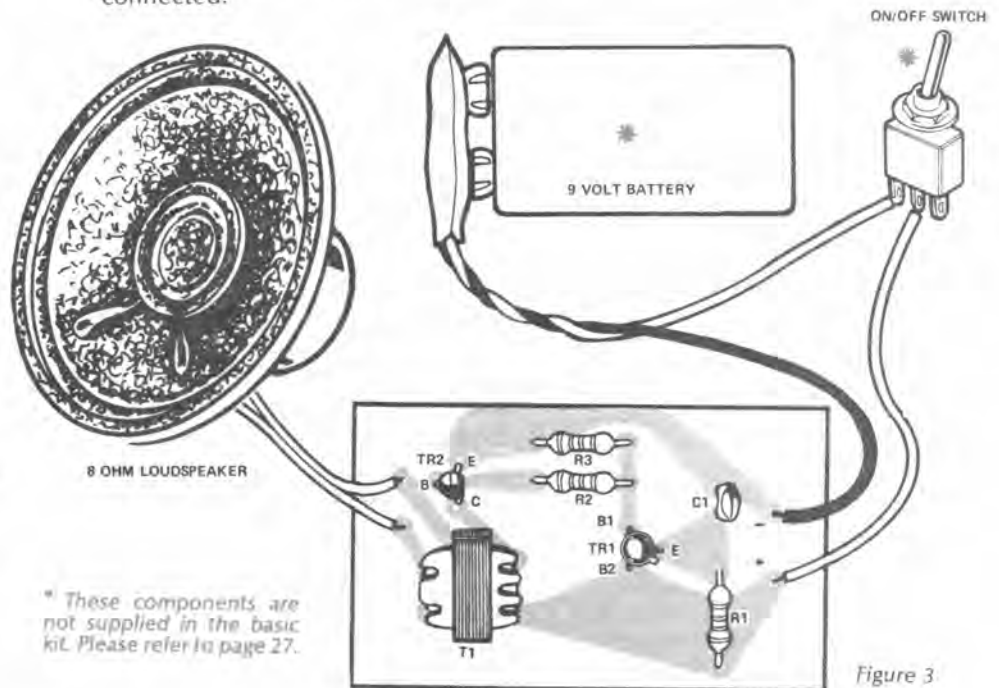

## checking that it works!

In order to prove that your mosquito repeller is actually operating, you can try substituting larger capacitors for C1 (try 0.022uF or 0.01uF). This increases the time constant of the network, resulting in less cycles per second. The frequency then falls into the range you can hear.

Once you've checked that it does work, don't forget to change the capacitor back to the original 0.0022uF shown on the circuit – otherwise, your mozzies will never get the message they're not wanted!

## what to do next

To protect the components of your mosquito repeller and to make it more convenient to move around and switch on and off, you may wish to mount it in a plastic box as we have shown in the drawing.

Using the label provided as a guide, prepare a box as shown in the drawing. (DSE Cat. H-2753 is an ideal size box.) Mount the speaker and board in the box, leaving room for the battery which may be held in place with a piece of foam. Alternatively a socket may be fitted to enable you to use a battery eliminator and save the cost of replacement batteries. (DSE Cat. M-9525 is a suitable battery

eliminator and requires a Cat. P-1231 3.5mm panel socket.) Paste the label provided, neatly over the switch and speaker baffle holes, screw the back on the box and your mosquito repeller will look like a bought one!

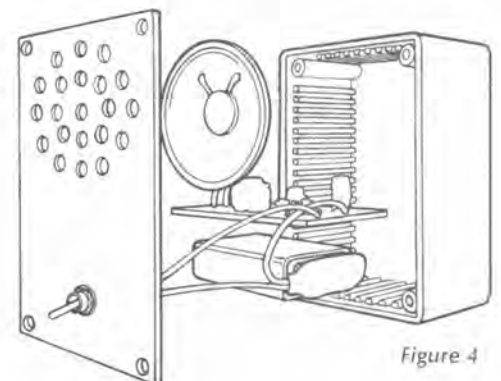

Figure 4

# milestones in electronics: the birth and growth of the integrated circuit (IC)

## Birth:

After the transistor was invented in 1947 (see page 35) a flurry of activity followed from existing valve makers and other companies. The first transistor was extremely frail but manufacturers soon developed ways of making them very rugged.

Most of the early 50's were devoted to improved manufacturing techniques so that the price of the transistor could be brought within reach of the average consumer. In 1954 the first pocket 'transistor' radio was seen.

But in those days the military was the biggest customer by far. They funded research into better transistor designs because they were far more concerned with performance than price.

They weren't **only** interested in better transistors, however . . .

During World War II military planners discovered that the cost, complexity and (un)reliability of a piece of electronic equipment went up at a far greater rate than the component cost increase. In other words, when a piece of equipment became large and complex, the cost of assembling that equipment became a greater proportion of its total – and because of its complexity, it was more likely to break down anyway!

In addition to this, other factors worked against large scale construction. Interconnections between circuits became long and involved, for example. These connections would radiate energy, pick up noise from other circuitry, or simply lose energy through resistance. The equipment would tend to get physically large and heavy as a result of increasing mechanical considerations. In addition to this, the amount of energy that the circuit consumed was enormous, and it became a problem to make provisions to keep the equipment cool enough to operate satisfactorily.

Obviously, the best way to solve this problem was to simplify the circuitry as much as possible. To this end military planners saw the relatively simple transistor (compared to the mechanically complex valve) as a major contributor to circuit simplification.

Another major contributor was the concept of the 'printed circuit'. In order to reduce wiring the concept of conductive tracks on an insulating substrate (or base) was developed. This led directly to the PCB's that we use in this book!

It did not take long for someone to realise that you could mount several of the actual transistor chips on the substrate and wire them together with tiny wire bonds – along with tiny capacitors and resistors. The whole circuit was then sealed inside a metal container with the leads coming out of the sides through sealed glass insulators.

These were not integrated circuits, however. Today they are called 'hybrids' (they had other proprietary names then).

At Texas Instruments (now the world's largest semiconductor manufacturer) in 1958 Jack S Kilby had a hard look at the idea of packaging circuits and came to a remarkable conclusion. He reasoned that capacitors and resistors could in fact be made of the same material as the transistors themselves. This meant that the entire circuit could be made on the one piece of germanium (or silicon) material with the circuit elements 'embedded' or **integrated** into that material.

Less than 11 years after the first transistor was

made, the **integrated circuit** was born. On September 12th, 1958, Kilby demonstrated an IC phase shift oscillator that worked at 1.3MHz. On September 19th he demonstrated an IC 'Flip Flop' circuit (see page 93) to show that digital circuits could also be built. The implications for the fledgling computer industry were enormous.

Kilby's IC was rather cumbersome, unfortunately. It still used fine wire connections between circuit elements. His ICs were also made of germanium which proved to be an inferior material to silicon (for IC's).

In the same year at a company called Fairchild, a group of engineers had developed the first transistor manufactured by a process which is still the same today. A team lead by Jean Hoerni used a process called **gaseous diffusion** to produce a new type of transistor. It offered prospects of consistency and reproducibility hitherto unknown in semiconductor manufacture. A later development of the diffusion process produced an even better transistor. This transistor was made using the 'Planar' process.

Robert Noyce, the manager of R&D (Research and Development) realised that if Kilby's integrated circuit could be married with Hoerni's Planar process, the result would be a better integrated circuit.

Fairchild did this. Instead of using delicate wire interconnections, the connections became part of the solid mass of the silicon itself. This rendered the circuit **monolithic**. Today most integrated circuits are monolithic.

The true IC was born – and it was electronics' answer to simplifying the complex.

## Growth:

It was not really until 1962 that IC's became a commercial reality. But now, the race was on! Fairchild and Texas were joined by other manufacturers.

The IC was primarily developed to simplify circuitry; however unexpected benefits (arguably exceeding the original purpose!) resulted. While the first IC's were very expensive, and virtually hand made, once manufacturers learnt a bit about them they became easier and cheaper to produce. The cost of the IC plummeted.

The lower costs meant new non-military markets for the IC – further helping to bring the prices down. As a result of the simplicity and manufacturing processes, the IC was **extremely reliable**, the main objective for many organisations such as NASA.

Another benefit, of course, was the miniaturization of equipment; again a military consideration. Another was the fact that the IC consumed very little power compared to its predecessors, opening up new applications for this device.

As IC's got cheaper manufacturers realised they would be making more and more IC's for less and less money. In order to reasonably justify higher prices, manufacturers produced products that offered greater performance than cheaper IC's.

The name of the game was to pack more and more circuit elements onto the one chip of silicon. So successful have manufacturers been in this regard that the number of elements packed onto a chip has almost **doubled every year** since the IC was first invented! That is an absolutely staggering achievement when you think about it. And there is no sign that the trend is slowing down, either!

The technology that has maintained this growth is so advanced now that it is dominated by only a handful of companies – mainly based in the USA.

Products that have over 250,000 circuit elements in them are now entirely feasible. By the mid 1990's Robert Noyce estimates that IC's with  $10^9$  elements will be available: if somebody wants them!

The only thing that will slow this development down is economic necessity. The applications for such complex circuit functions are not all that great.

We are now only just beginning to be influenced by the effects of the integrated circuit (or micro chip as the popular press likes to call it). Because of the incredibly low cost and awesome processing powers of these devices, the applications for them will explode in the 80's!

*This graph dramatically shows the incredible growth of the integrated circuit since it was first demonstrated on September 12th, 1958. Amazingly, researchers have managed to double the number of components, or circuit elements, per chip each year since its introduction!*

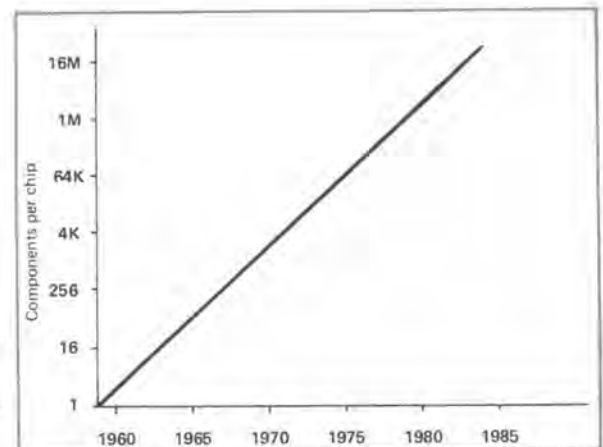

# project number ten

## Simple Amplifier

One of the most popular projects made by electronics hobbyists is the audio amplifier. After all, an audio amplifier is particularly useful: as well as the more obvious uses, it can be used to trouble-shoot other projects (you'll see how in this project).

Amplifiers are one of the most common of all electronic circuits: every piece of communication and entertainment equipment has at least one! But they all work in much the same way: they take a very small electrical signal (one which is too small to be of much use) and add power to it, producing a much larger signal.

Here's a simple amplifier you can make for relatively low cost, but one which should prove very useful.



## you will need these components

### Resistors:

- R1 10k ohms
- R2 68k ohms
- R3 1k ohms
- R4 2.2k ohms
- R5 22 ohms
- RV1 10k ohms trimmer potentiometer.

### Capacitors:

- C1 10uF 16V electrolytic
- C2 10uF 16V electrolytic
- C3 .01uF disc ceramic
- C4 100uF 16V electrolytic
- C5 .047uF disc ceramic
- C6 470uF 16V electrolytic

### Semiconductor Devices:

- TR1, TR2, TR3, TR4 NPN type DS548 transistors or similar.
- D1 1N914 diode

### Miscellaneous:

- T1 Audio coupling transformer 3k ohms - 3k ohms.
- T2 Audio output transformer 1k ohms - 8 ohms (centre tapped) 8 ohm loudspeaker
- Battery snap, solder, hook-up wire.

You will also need a 9 volt transistor battery (not normally supplied with a kit.)

A suitable mounting board or printed circuit board of correct design (DSFW2 K-2630 Audio Amplifier Kit contains the correct PCB.)

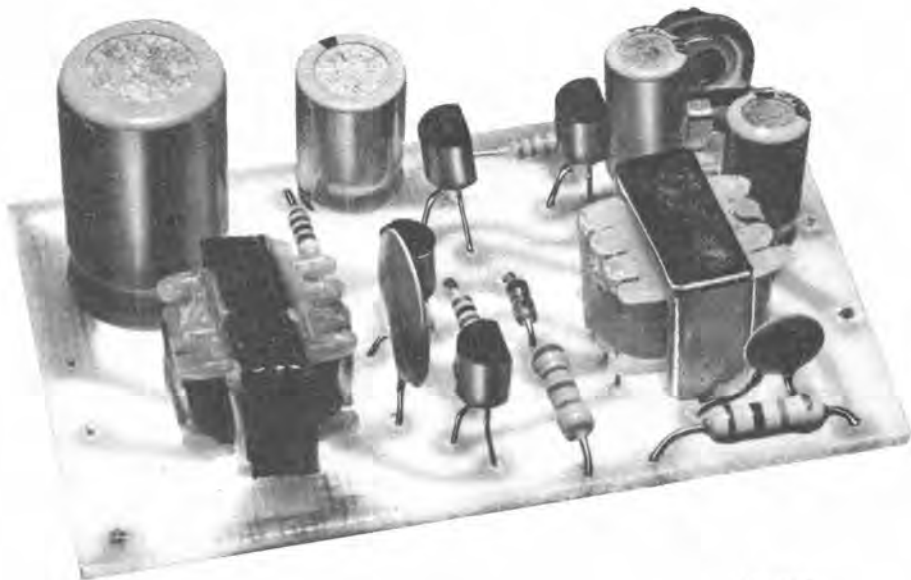

Figure 1



# putting it together

- (1) If you have purchased a kit (Dick Smith Cat. K-2630 or similar) check off the components against the above list to make sure they are all there and are the correct types and values.
- (2) If you have not purchased a kit you will need to obtain the components listed and either make a printed circuit board using the component drawing as a guide, or use Vero board or perforated board and the component drawing as a guide.
- (3) Mount the components as shown in the component drawing – resistors and capacitors first taking great care to ensure that C1, C2, C4 and C6 are correctly polarised (don't forget 'dress'.) Then solder these in.
- (4) When mounting the two audio transformers be very careful to ensure that you have the correct one in the correct place and that

it is the right way around. Note that the coupling transformer has three wires on each side but that only two are used on the primary side, the spare one being bent up out of the way.

The output transformer has three wires (one centre tap) on the primary side and only two on the secondary or output side. Although they look very similar these transformers are definitely not interchangeable!

- (5) Solder the diode in, again ensuring that it is the right way around.
- (6) Very carefully place the four transistors so that they are the right way around and solder them in using a heatsink clip to prevent damage from overheating.
- (7) Solder the speaker wires to the board and then to the speaker, making sure that you do not damage the speaker by

overheating.

- (8) Solder the wires from the battery snap to the board, making sure that they are correctly polarised, i.e. red to positive (+) and black to negative (-).
- (9) Clip off all excess wire neatly, making sure that all of the soldered connections are properly made.
- (10) Check all components to ensure correct polarity and position before connecting the battery.
- (11) The circuit should now be 'ready-to-go', but of course you will get nothing out of it until you connect an input. To test it connect the battery and touch two wires together connected to the input terminals. This should produce a clicking in the speaker. (See "What to do next" for practical applications for your Basic Audio Amplifier).

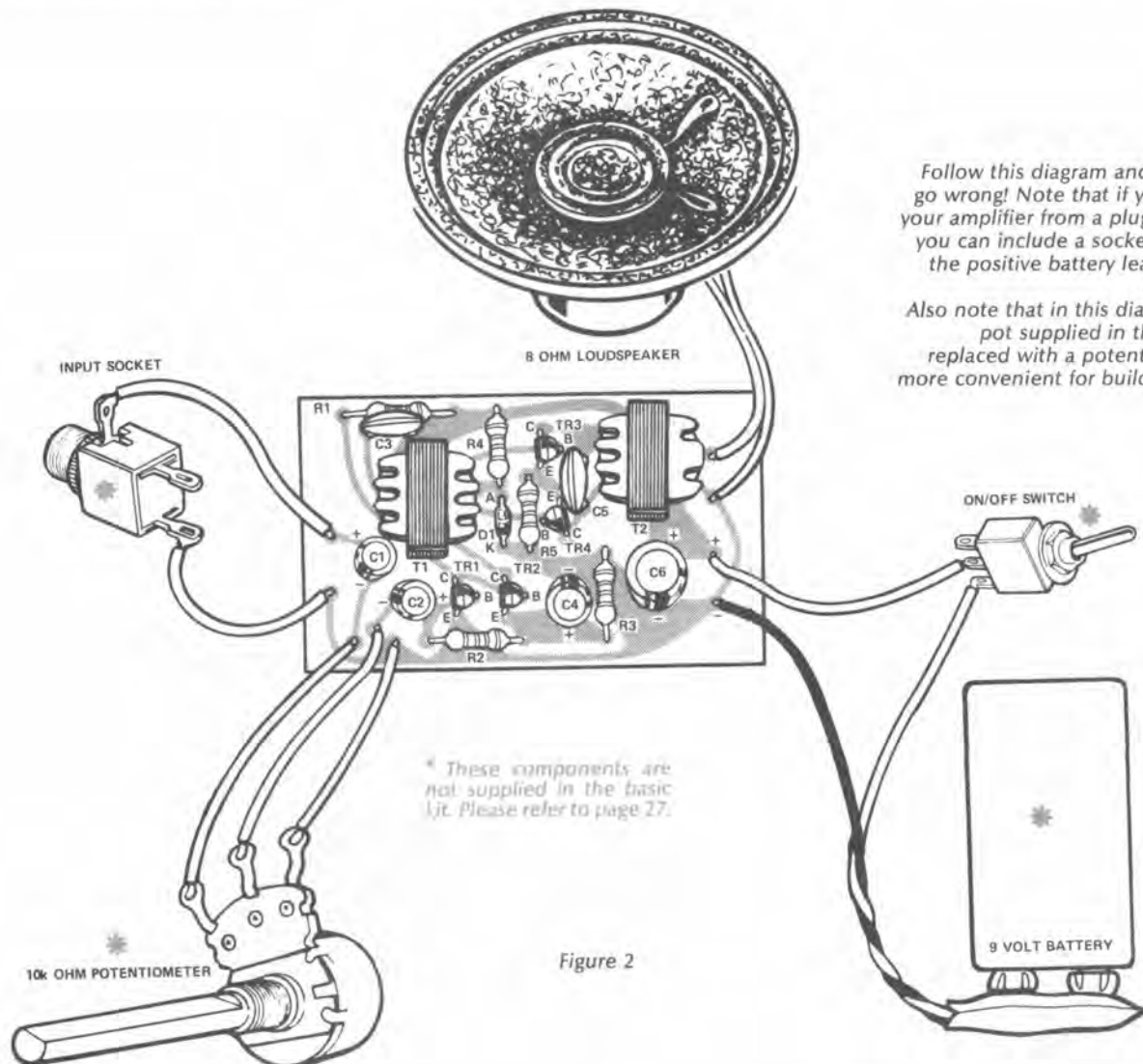

Follow this diagram and you shouldn't go wrong! Note that if you want to run your amplifier from a plug-pack adaptor, you can include a socket in series with the positive battery lead, as shown in other projects. Also note that in this diagram, the trim-pot supplied in the kit has been replaced with a potentiometer: much more convenient for building into a box!

Figure 2

# how it works

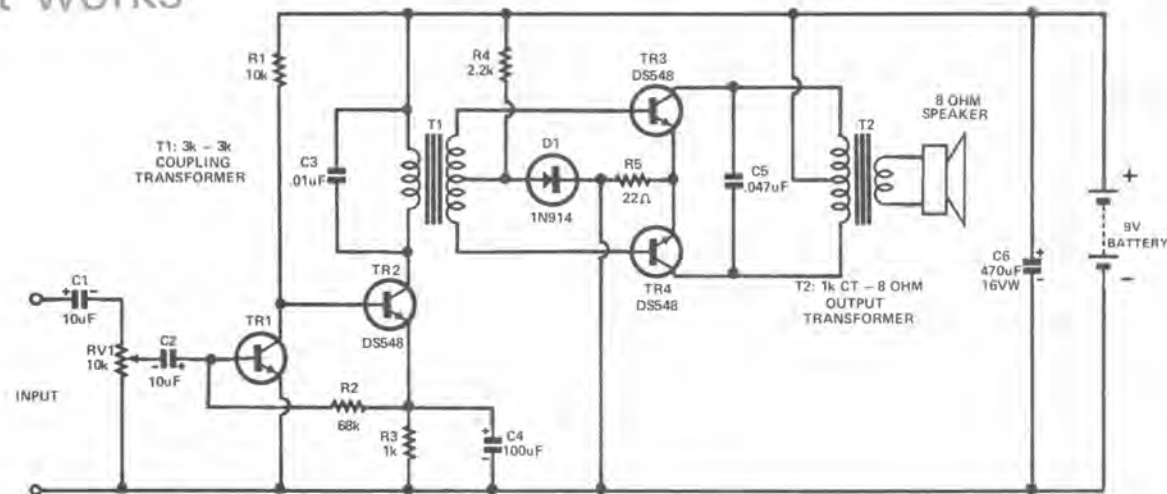

Figure 3

RV1, the 'volume control', selects a certain proportion of the applied audio signal to be amplified. C1 and C2 do not impede the audio signal: they are in the circuit merely to prevent any DC (direct current) flowing through the potentiometer. DC flowing through a potentiometer in an audio circuit can make them noisy.

TR1 and TR2 amplify the audio level significantly, but not enough to drive a loudspeaker. TR1 and TR2 can be regarded as a 'pre-amplifier'.

The varying output current of TR2 must pass through the primary winding of T1. A varying voltage is hence induced in the secondary of T1, but you may have noticed that the secondary of T1 is split in half. Two separate currents flow in the secondary: each identical to the other, but opposite in phase. This means that at any given instant, the two voltages are of the same magnitude, but where one is so many volts above zero, the other is the same number of volts below zero (a minus voltage).

If the last paragraph was confusing, don't let it worry you. Phase

relationship is quite an involved subject: it will all come to you eventually!

What these out-of-phase currents do, however, is the secret behind this type of audio amplifier circuit.

We have mentioned before that audio signals are alternating current: that is, they follow a fixed cycle. On the first half cycle, the voltage from the top end of the transformer might be going positive, and the voltage from the bottom end going negative. In the next half cycle, these roles are reversed: the top end goes negative, while the bottom end goes positive.

As you may remember, an NPN transistor needs to have a positive voltage (of at least 0.6V or so) applied to its base before it can conduct. Obviously, if the voltage from T1 is negative during any half cycle, the transistor does not conduct. But during the next half cycle, the transistor which was off turns on as the waveform swings positive (and vice versa).

In fact, R4 and D1 keep the transistors just about conducting – so that the

moment the signal voltage does go positive they conduct immediately. Because each transistor can be driven harder during its half cycle, this arrangement is much more efficient than using a single transistor to do the same job. So we get more power output. C5 is connected between the two transistors to minimise the distortion which can occur as one transistor turns off and the other turns on.

Both TR3 and TR4 are connected to the positive supply via half the winding of T2 – so the current flowing through them must also flow through the transformer.

In exactly the reverse of T1, where two out-of-phase currents were induced in the transformer from a single input signal, T2 induces a single output current in its secondary from two out-of-phase currents in its primary. This output is enough to drive a loudspeaker.

This type of circuit is called a 'push-pull' amplifier, as in the first half cycle one transistor 'pushes', then in the second half cycle the other 'pulls'.

## what to do next

The first step is to house your amplifier in a protective case. The PCB has been made to slot sideways into a zippy box, as shown in the drawing. There is enough room in this zippy box for the speaker and battery, too. We have shown the amplifier with a standard potentiometer instead of the trimpot supplied with the kit: this is much more convenient if you are going to use it mounted in a box.

A power switch is also shown on the box, along with an input socket. These are also shown in the exploded drawing.

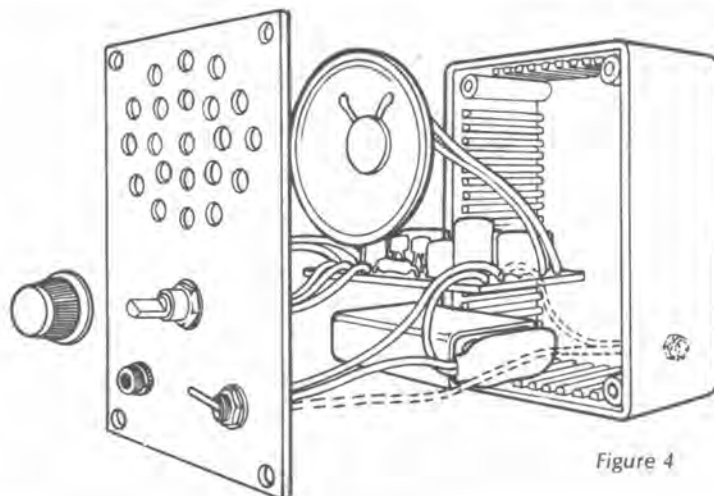

Figure 4

## what to do next . . . continued

If you wish to run your amplifier from a plug-pack adaptor, a socket can be wired in series with the battery, as shown in many other projects in this book. This is, in fact, shown dotted in figure 4.

Here are some applications for your amplifier:

### Megaphone:

Remove the 8 ohm loudspeaker from the output of the amplifier, and instead fit it to the input. Connect a horn speaker (DSE Cat. C-2705 or similar) to the output terminals, and speak into the original speaker, now acting as a microphone. Your voice will be amplified, just as in a megaphone or loud hailer!

### Portable radio:

Using the pocket transistor radio, you can quite easily make up a portable transistor radio with this amplifier. A speaker is much more convenient than an earphone!

Start by removing the wires to the earphone socket from the PCB, and in their place solder a 100 ohm resistor. The two wires to the socket are then re-soldered to the PCB each one pad

to the right of their previous position: They now connect to the collector of TR1 and the negative supply.

The two sockets can be connected together via a short twin 'jumper lead' with 3.5mm plugs on each end.

A further refinement is to place both the radio and amplifier PCB's in the same box, running from the same battery, and wired directly together so

that no sockets are involved. This is shown in the drawing below.

It should be obvious by now that other projects can be amplified in the same way as the radio: for example, the Monophonic Organ, and Shortwave Radio, described elsewhere in this book. In both cases, refer to these projects for more detailed connection diagrams.

*Wiring the portable radio and amplifier together: note the new 100 ohm resistor included. Otherwise the pcb's are the same. It may appear that a battery lead has been left off the amplifier pcb: the black 'signal' lead on the left side is also the negative supply.*

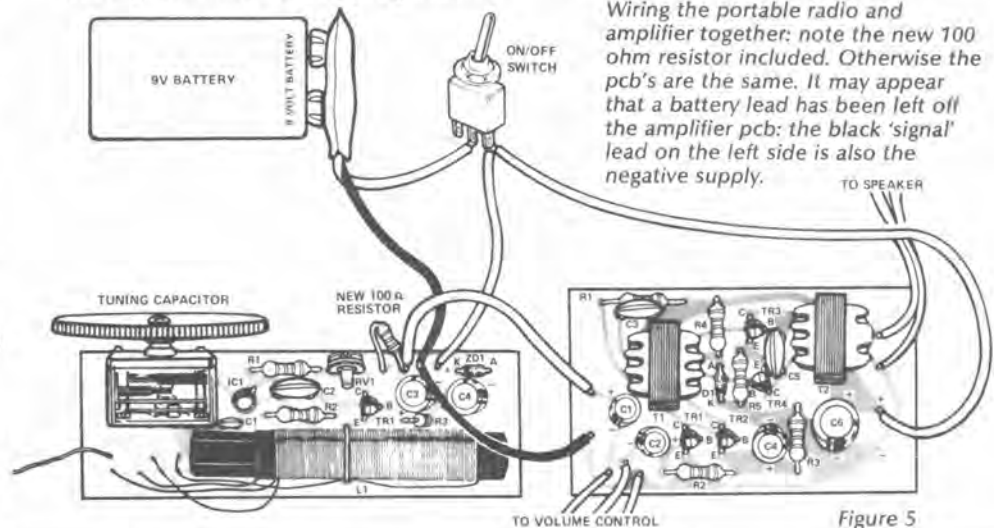

Figure 5

## making a signal tracer

As we mentioned in the introduction, this amplifier can be used to troubleshoot other audio projects, or do simple service work.

For example, a stereo amplifier works in one channel, but not in the other. Where is the fault?

By connecting the input to the amplifier to a 'probe', you can trace the circuit back from the speaker towards the input of the dead channel, until you find the point where there is signal. Obviously, the fault is somewhere in this vicinity. Then, using your multimeter, you can compare components and voltages between the good channel and the dead one to identify the component or components that need replacing.

Simple, isn't it?

A word of warning! This amplifier is ideal for use as a signal tracer in 99% of the solid state (transistorised/IC etc) circuits you are likely to come across. However, it is not suitable for a lot of valve circuits. Apart from which, valve circuits contain a lot of fairly high voltages. So if you're not careful, you might get zapped! Keep away from valve circuits, for safety's sake. Of course, you should also keep well clear of any power supply or mains wiring in transistor circuits, too!

*Using the amplifier as described, a handy signal tracer can be made for solid-state audio projects.*

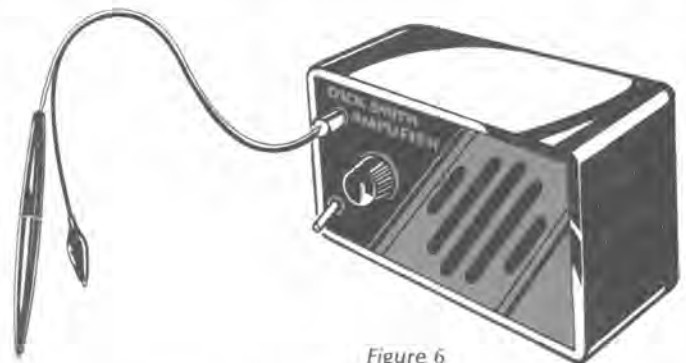

Figure 6

To build a signal tracer, all you need do is make a probe (similar to the stylus on your electronic organ) and solder a length of wire to it (say around 350mm or so). Solder the other end of this lead to the centre pin of a 3.5mm plug (see drawing). Another length of wire connects the barrel of the 3.5mm plug to an insulated alligator clip (black is the best colour, but it really doesn't matter).

Plug this lead into your audio amplifier and connect the alligator clip to the negative supply (or 'earthy' rail) of the circuit to be tested. Your probe can then be touched onto various points of the circuit to see what signal is present: any signal will be amplified by the audio amplifier and heard from the speaker.

*Figure 7: This shows the detail of the probe assembly. Detail of the 'tip' of the probe can be found in project 6: the electronic organ.*

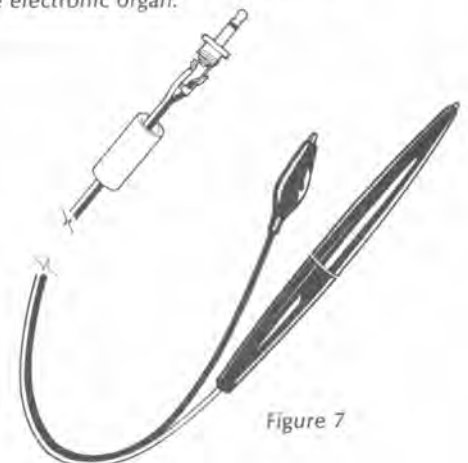

Figure 7

# project number eleven

## FM Wireless Microphone

Ever wondered how concert performers move around the stage without a microphone lead? Simple: they use a microphone with a tiny transmitter built in! Here's one you can build in an hour or so – all you need to receive it is a standard 88 – 108MHz FM band receiver.

And you can make a tiny version to use as an electronic 'bug': James Bond, move over!



you will need  
these components

### Resistors:

R1 22k ohms  
R2 47k ohms  
R3 10k ohms  
R4 100 ohms

### Capacitors:

C1 .047 uF green cap  
C2 470pF ceramic  
C3 470pF ceramic  
C4 3.3pF ceramic  
CT1 6 to 20pF trimmer capacitor

### Semiconductors:

TR1 DS548 or similar NPN transistor

### Miscellaneous:

Electret microphone insert  
Battery snap, solder, hook-up wire, a few cm of tinned copper or hook-up wire for the antenna (see text)

You will also require a 9 volt transistor battery (not normally supplied with a kit) or some other 9 volt DC power supply.

A suitable mounting board or printed circuit board of correct design (DSFW2 K-2631 **Wireless Microphone** kit contains the correct PCB.)

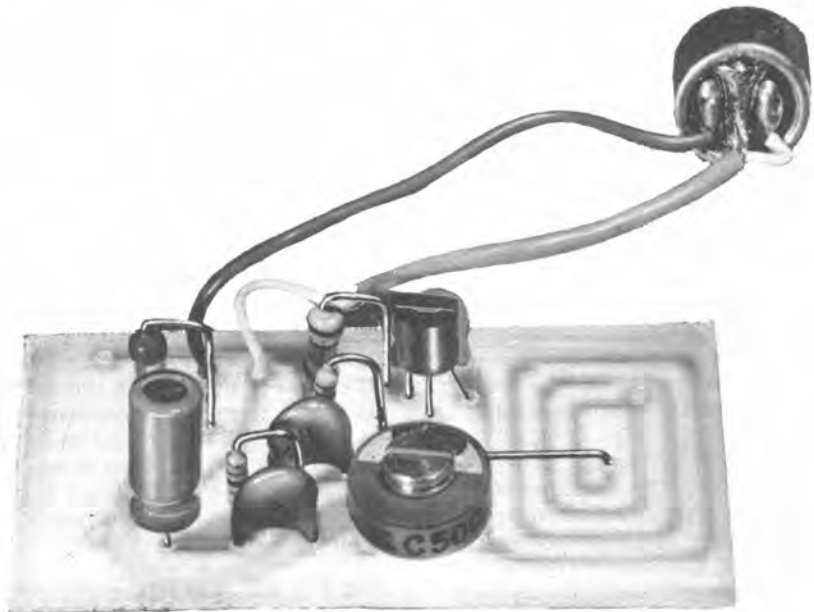
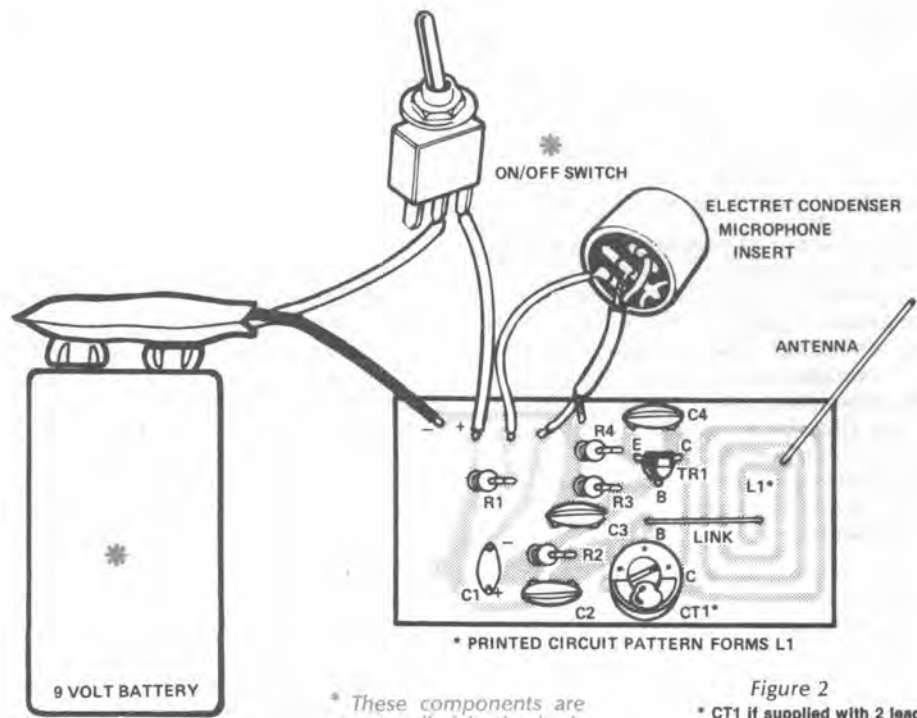

Figure 1

# putting it together

- (1) If you have purchased a kit (Dick Smith Cat. K-2631 or similar), check off the components against the above list to make sure they are all there and are the correct types and values.
- (2) If you have not purchased a kit you will need to obtain the components listed and either make a printed circuit board using the component position drawing as a guide, or use a perforated or tracked board.
- (3) Mount the components as shown in the component position drawing. Place and solder the resistors and capacitors first. Note in particular how the resistors are mounted to save space. Take extra care to ensure that C1 is the right polarity. The negative side goes to one side of the microphone insert. Check that all components are neatly placed and properly 'dressed' before soldering them in.
- (4) Solder the trimmer capacitor, CT1, in place. You shouldn't make any mistakes here, as it has to be forced in to get it in the wrong way!
- (5) Now connect and solder the electret microphone insert with the red lead to the positive track, the white lead to the negative side of C1 and the shield to the negative track. Solder in the wire link that connects the centre of the coil to the positive track.
- (6) Solder in TR1 the DS548 NPN transistor, noting that it is the right number first and that you place it so that the collector goes to the coil etched onto the PCB. Use a heatsink clip when you solder to prevent damage to the transistor from overheating.
- (7) Solder in a short length of wire for the antenna to the position shown on the PCB. This can be virtually any wire, a short length of insulated hook-up wire is ideal (say about 20cm or so). Or you can make it a similar length of stiff tinned copper wire, so that the antenna remains rigid. (Make sure the wire cannot short circuit onto any other components or tracks on the PCB).
- (8) Connect and solder the battery snap with the red (positive) lead going to the pad marked '+' and



\* These components are not supplied in the basic kit. Please refer to page 27.

Figure 2  
\* CT1 if supplied with 2 lead trimmer (CT1) Insert between point B & C

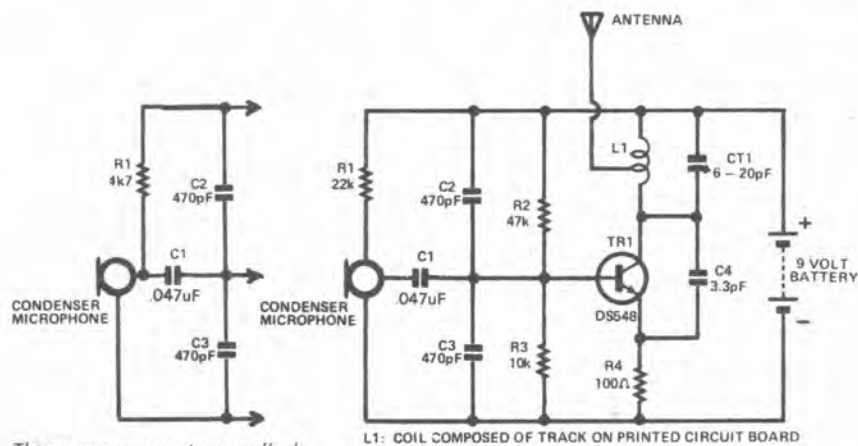

These components supplied only for use with two lead mic inserts.

Figure 3

the black (negative) lead going to the pad marked '-'. If you want to add a power switch and/or socket for external power, these can be added now too: follow the diagrams for correct connections.

- (9) Before you connect the battery check again that all of the components are in the right place, are correctly oriented and soldered in properly. Clip off all excess leads carefully.

- (10) Connect the battery and switch the transmitter on. If you tune a nearby FM receiver over its band, you should hear it go very quiet in one (and possibly more) tuning positions. Talk into the

microphone and you should hear yourself coming from the receiver. If not, try re-tuning the receiver, and/or adjusting the trimming capacitor, CT1, until you hear yourself.

See 'What to do next' for more tuning details and other ideas to try.

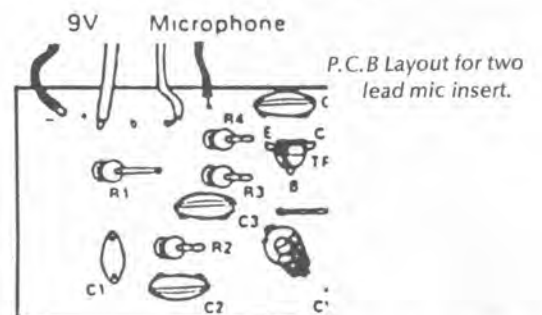

# how it works

If you don't know how radio waves are generated and transmitted, it would be a good idea to read the section 'Understanding radio' in the back of this book – otherwise you might find this description fairly heavy going!

As we explain in that section, a radio wave is generated by a radio frequency oscillator, and radiated by an aerial or antenna. This radio wave – or continuous wave – cannot convey any message or intelligence of itself: it must be interrupted to form a code of some description (e.g. Morse code); or some form of detectable signal must be impressed on the continuous wave. We do this by a process called 'modulation'.

There are two basic types of modulation: amplitude modulation, where the level of the continuous wave is varied in accordance with an audio signal; and frequency modulation, where the amplitude remains constant, but the frequency is 'wobbled' over a small range in accordance with an audio signal.

It is the latter we use in the wireless microphone: in many ways, a frequency modulated wave is one of the easiest to produce, but is slightly more difficult to receive than an amplitude modulated wave.

The transistor TR1 with its associated components R3, C4 and the 'tuned circuit' consisting of CT1 and L1, act as a radio frequency oscillator with a frequency of approximately 100MHz. This frequency is variable over a small range by the trimmer capacitor, CT1. Any variation in the oscillator due to component tolerances, etc, can be accounted for, and the frequency of the transmitter brought back into the range of 88 – 108MHz, the range of FM receivers.

With no sound input to the microphone, the oscillator just keeps on producing an alternating voltage across the tuned circuit (while ever power is applied). A small amount of energy escapes from the tuned circuit – and is radiated as a continuous wave. If we 'tap' into the coil with an aerial of some sort, significantly more

signal is radiated.

If we wished, we could use the circuit in this basic form with a Morse key to produce a 100MHz continuous wave Morse code transmitter.

But we want to transmit voice! To do this we use a microphone, which produces a small voltage when it receives sound waves. This voltage, which is varying with the sound input, is applied to the base of TR1 via C1. While the voltage is small, it is enough to upset the balance of the circuit created by C2, C3, R1 and R2 – and cause the frequency of the oscillator to vary. The frequency variations occur as the voltage varies; and obviously if the voltage is varying in sympathy with the sound input to the microphone, the frequency variation of the oscillator must contain the original sound patterns.

So the frequency variations produced by the oscillator are a reproduction of the sound received – in other words, the frequency is being 'modulated' by the input voltage. Hence the name: frequency modulation.

# what to do next

The first step, even before putting the Wireless Microphone into a box, is to adjust the frequency of the transmitter so that it falls into the range of 88 to 108MHz – the band covered by a standard FM broadcast receiver.

With the numbers of stations on the FM band growing all the time, you might have to search for a clear spot on the dial first, and tune the transmitter to that. Otherwise you might end up transmitting on the same frequency as a 50,000 watt FM station – and we know which transmitter would win that little battle!

As you are probably aware, the transmitter's frequency is controlled by a 'tuned circuit', which consists of a coil and a capacitor. Varying either of these components varies the 'resonant frequency' of the tuned circuit, and thus the transmitter's frequency. Because the coil in this project is actually an etched track on the printed circuit board (and therefore a little difficult to change!), we have included a variable capacitor to adjust the frequency.

Tune your FM receiver to a relatively free spot on the dial, and turn on the wireless microphone transmitter. Slowly adjust the variable capacitor over its entire range, and you should hear the receiver go quiet at one point. You might also hear a

Figure 4

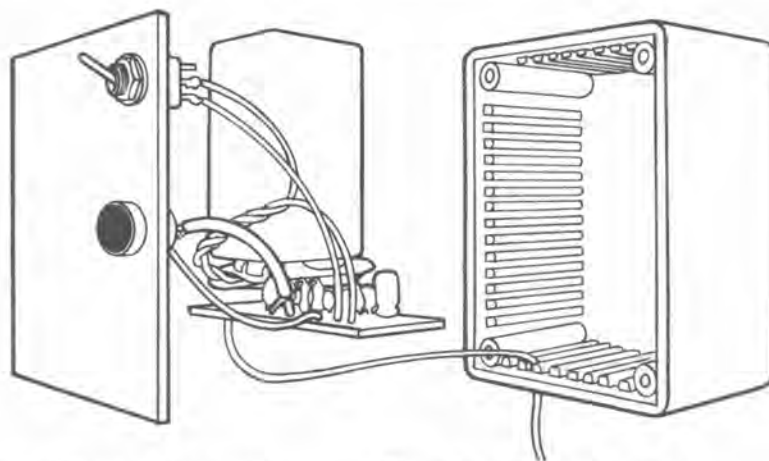

'wooshing' sound as you tune onto this point. Or, if your microphone is too close to the receiver's speaker, you might get acoustic feedback between the two, resulting in a howl or squeal from the speaker.

Once the transmitter is tuned in, you might like to mark the frequency (as read from the receiver dial) in the space provided on the front panel. This is so you don't have to go through the tuning procedure again: any FM receiver set to that frequency should operate in the same way.

## Fitting it into a box

The PCB slots in sideways into the 'baby' Zippy box, with enough room left over for the battery, switch and microphone. This makes the whole transmitter fairly small.

There is nothing to stop you lengthening the wires from the microphone insert to the PCB, if you want to use the microphone external to the box. However, make sure you use shielded wire, as shown in the layout diagram, for the audio connections to the microphone.

## The 'antenna'

A short length of wire attached to the coil will radiate enough signal for close range operation, but for longer ranges, the antenna can be made more efficient. An antenna is simply a device designed to 'lose' energy (in the form of radio waves). A good antenna simply loses more energy!

While you can use a random length of wire (even a piece of tinned copper wire a few centimetres long will do),

## ERRATA - K-2631 WIRELESS MICROPHONE

1. Please note of the conversion that has to be made if a 2-lead type electret microphone insert has been supplied. The link is soldered on the copper side of the PCB.

2. Resistor R1 has been changed from 22K ohms to 4.7K ohms.

3. CV1 should read as CT1 and if supplied with a 2-lead trimmer capacitor, please use points B and C only.

4. Capacitor C1 has been changed from a 2.2 $\mu$ F electro to 0.047 $\mu$ F greencap. It is non-polarised (i.e., it does not matter which way around you put it in), its position remains the same.

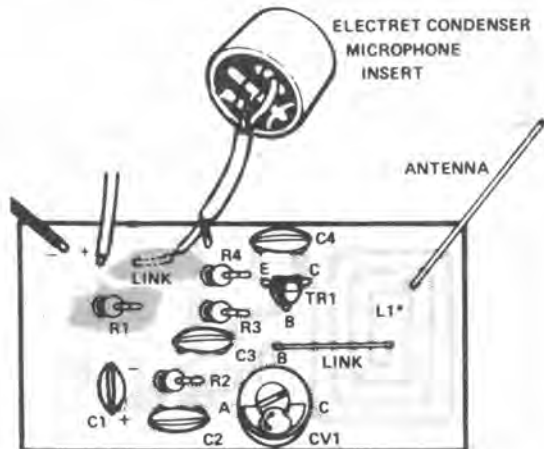

\* PRINTED CIRCUIT PATTERN FORMS L1

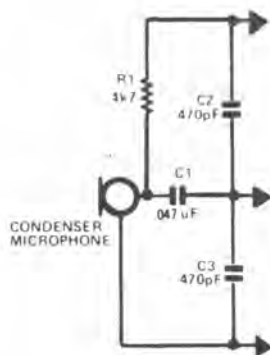

## what to do next . . . continued

the transmitter will perform better with a longer antenna. it will perform even better if you add a second piece of wire to the pcb to form what is known as a 'dipole' antenna. This second piece of wire is soldered to the pcb in the hole provided diagonally opposite to the aerial connection shown on the pcb component overlay.

You will get maximum radiation if both lengths of wire are approximately 75cm long; however, this can be a bit unwieldy! You can compromise on length without too great a loss of signal by simply making both halves of the dipole a convenient (but identical) length.

### Making a miniature 'bug'

This circuit can easily be modified to operate from a lower voltage, making it suitable for use with silver oxide or other very small batteries. Thus the whole transmitter can be made very small and inconspicuous – an ideal 'bug'!

All that is needed for low voltage operation (say around three volts or so) is to replace R1 by a wire link, and change R2 to 10k. This allows the transistor and microphone to operate more efficiently with the lower supply voltage.

Connections to these small batteries is

a bit of a problem (as discussed in project one). You might be able to make a simple battery holder as we did for the electronic jewellery, or come up with another idea for a suitable battery holder. As we mentioned in project one, these batteries **do not** like being heated: so don't try to solder to them. They might explode!

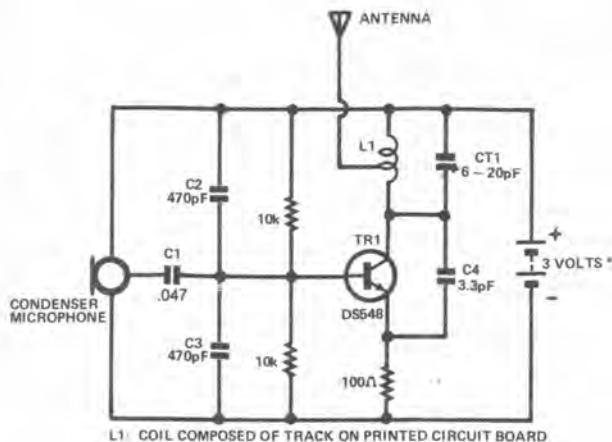

## what if I don't have the right transistor . . .

Here's an interesting question you will almost certainly want answered at some time during your electronics experiments:

### 'What do you do when a circuit calls for an NPN transistor, and all you have is a PNP type?'

In many cases, there is a very simple solution. In others, however, it is a case of 'tough luck!' Let's take a specific example:

Suppose you wanted to build the FM transmitter as described over the last few pages, and you had all the components excepting the DS548 transistor. On looking through your 'junk box', however, you find you've a DS558 transistor: the PNP equivalent of a DS548. Here's what you do:

Put in the DS558 in exactly the same position as the DS548. Then, reverse the connections to the battery and **all** polarised components in the circuit.

In the case of the FM microphone, this would mean reversing only C1, the 2.2uF capacitor, and the condenser microphone insert (the red

lead is swapped with the shield, while the white lead is left where it is).

The FM microphone is a particularly easy case: but if there were such things as diodes or other polarised components (don't forget tantalum capacitors are polarised), **all** would have to be reversed.

If there were other transistors in the circuit, obviously **all** of them would have to be replaced with the opposite types: you can't replace one and not the others!

What if the circuit contains integrated circuits, or a mixture of integrated circuits and transistors?

You're probably out of luck! Unless you know the particular characteristics of an IC and know exactly what, and how it works in the circuit, you cannot change their connections around and expect them to work. In all probability, you'll blow the integrated circuit up if you change its connections!

So remember: **If the circuit only contains transistors, they can normally be replaced with opposite polarity types if you also reverse all other polarised components.**

**If the circuit contains integrated circuits as well, you cannot normally make substitutions.**

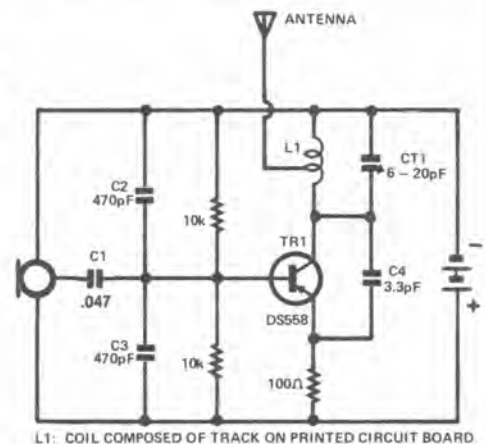



# project number twelve

## Light Activated Switch

It's late at night and everyone is asleep. The thief walks down the street, looking for a likely target. He picks your house.

The house is too exposed to the street for entry from the front, so he decides to take a look around the back.

Silently he sneaks along the passage: then suddenly a bell starts clanging. Instantly everyone is awake – and the thief is off!

Without knowing it, the thief walked into an invisible light beam, shining across the passage into your 'Fun Way' light activated switch. The moment the thief's body cut the beam, the alarm sounded.

Sounds too easy? Build the light activated switch and find out just how easy an alarm of this type is to make!

Of course, there are dozens of other applications for a light activated switch: build it and you could discover one of them.



## you will need these components

### Resistors:

- R1 4.7k ohms
- R2 4.7k ohms
- R3 120 ohms
- RV1 5k ohms trimming potentiometer

### Semiconductor Devices:

- TR1 & TR2 NPN type DS548 transistors or similar
- D1 1N4002 diode
- LDR1 Light dependent resistor

### Miscellaneous:

- RLY1 9-12 volt relay with changeover contacts
- Battery snap, solder, hook-up wire

You will also need one 9 volt transistor battery (not normally supplied with a kit) or some other 9V DC power supply.

A suitable mounting board or printed circuit board of correct design (DSFW2 – K-2632 **Light Activated Switch** kit contains the correct PCB).

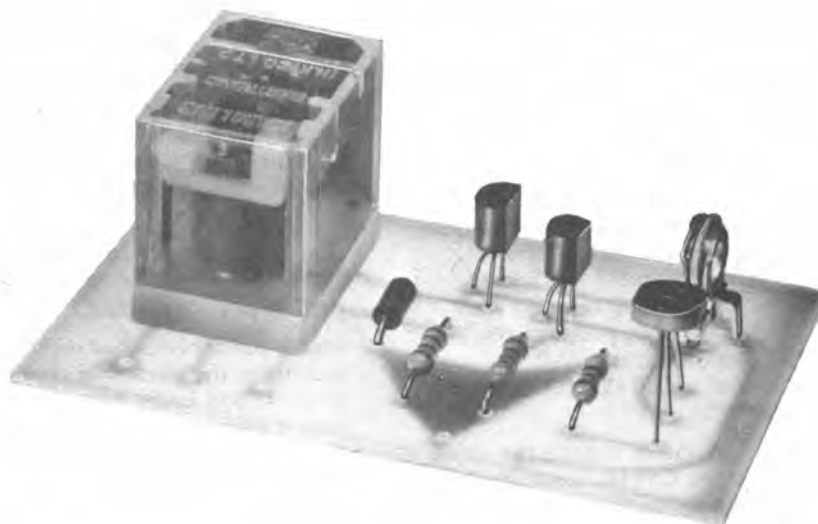
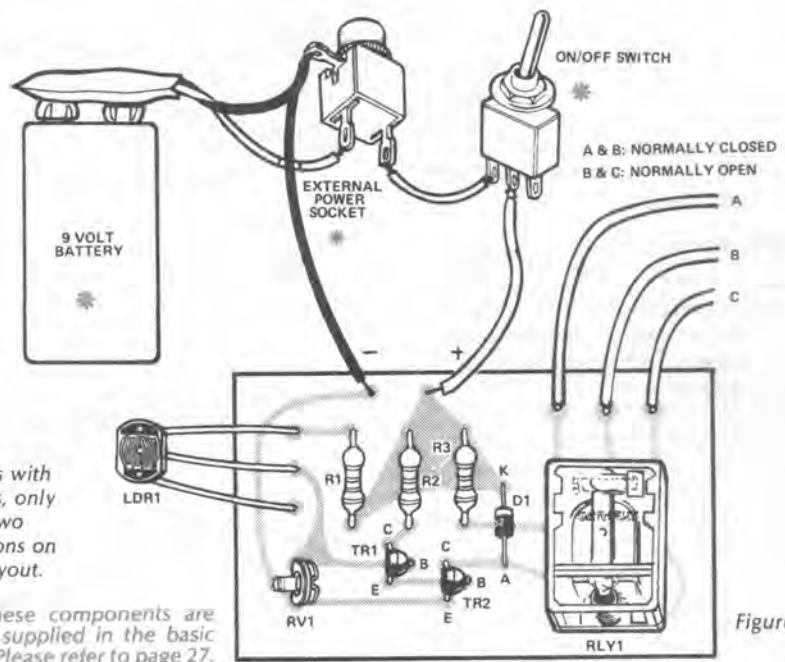

Figure 1

# putting it together

- (1) If you have purchased a kit (Dick Smith Cat. K-2632 or similar), check off the components against the above list to make sure they are all there and are the correct types and values.
- (2) If you have not purchased a kit you will need to obtain the components listed and either make a printed circuit board using the component drawing as a guide, or use Vero board or perforated board and the component drawing as a guide.
- (3) Mount the components as shown in the component drawing – resistors first (don't forget 'dress'). Then solder these in.
- (4) Position the relay RLY1 using the five pin configuration as a guide and solder it in.
- (5) Solder in the diode D1, making sure you have the correct polarity. Place LDR1 in the position shown and solder it in. It is not polarised but in some cases, if you have purchased a kit, you could be supplied with a double LDR, i.e. one with three leads. In this case the third lead (not the centre one) goes to the blank pad. Wired in this way only half the LDR is used and if at some time breaks down you can unsolder it and use the other half.



**NOTE!**  
For LDR's with two leads, only use top two connections on P.C.B. Layout.

\* These components are not supplied in the basic kit. Please refer to page 27.

Figure 2

- (6) Carefully position the two transistors TR1 and TR2 so that they are the correct polarity and solder them in, using a heatsink clip to prevent damage from overheating.
- (7) Solder on the battery snap lead, ensuring first that it is the correct polarity – red positive (+), black negative (-).
- (8) Clip off all excess wire neatly, making sure that all of the soldered connections are properly made.
- (9) Check all components to ensure correct position and polarity before connecting the battery.
- (10) Connect the battery. If LDR1 is in the light, the relay will probably operate immediately but will drop out as soon as you cover the face of the LDR with your finger.

## what to do next

The light activated switch PCB has been designed to fit into a slotted Zippy box. The LDR has been mounted on the edge of the PCB, so it is a simple matter to drill a hole through the side of the box for the LDR's light beam to pass into.

Naturally, the position of this hole will depend on exactly where you slot in the PCB; in all probability it will be around half way up the box side. Note that the LDR is not mounted dead centre on the edge of the PCB; make allowances for this when drilling your hole.

Because the light activated switch is a device which can be left for long periods, we imagine that most constructors will want to add the optional external power socket, along with an on/off switch. Wiring details for both of these are given in the PCB layout diagram and the exploded drawing.

We do not suggest leaving out the

battery altogether: it makes a handy power supply failure back-up.

There is plenty of room inside the Zippy box, so if you are building a 'door minder', you might as well include the buzzer inside the box. A small piezo buzzer such as the Dick Smith L-7009 is ideal in this application; it is polarised, however, so watch the connections. The negative lead goes straight to the negative supply (the negative lug on the external power supply socket is a good connection point); the positive lead goes to one of the 'normally closed' contacts of the relay (A or B in the PCB layout), while the other normally closed contact is connected to the positive supply (at the on/off switch, for example).

(We use the 'normally closed' contacts of the relay because in this role, the operation is reversed: if light is shining on the LDR, the relay pulls in. If someone walks in front of the LDR, the relay drops out – therefore, the

contacts labelled 'normally closed' are becoming the 'normally open' contacts! Confusing, isn't it. . .)

If the light activated switch is being used as part of a security system, use the contacts that best suit the system. But remember our comments above about 'reversed roles'! Either set of contacts could be wired into our Home Alarm (project 15).

There are other uses besides alarm circuits for this project: for example an automatic darkroom warning light. As soon as the darkroom lights were turned off, this project could not only light a 'darkroom in use' light, but also turn on the darkroom safelight!

Or you could make a letter box monitor: a light inside the house could come on if letters were dropped in, hiding the LDR from a small light inside the letter box.

# what to do next . . .continued

Don't forget that the relay contacts can be made to switch another, larger relay with more contacts and/or more carrying capacity. You could even make the light activated switch 'latch' on once triggered.

## The light source

You have a choice of light source for your light activated switch; you can use artificial or natural light that is present anyway (ambient light), or make up a special light source. An example of using natural light is in a dusk monitor: after sunset, the LDR goes dark and the relay drops out. This could switch on outside lights, etc. Another idea is where the LDR is in a room which should stay dark at night. If a light is turned on, the LDR detects it and sounds an alarm!

Just think: you can now find out who has been raiding the fridge for a midnight snack!

A good example of a specially made light source is in a door minder. A beam of light is shone across the doorway to where the LDR is located. If anyone steps into the beam and breaks it, the light activated switch triggers a buzzer or light (as we have detailed above).

A single low voltage bulb on its own is often enough, but for best results, the beam should be focussed. You can

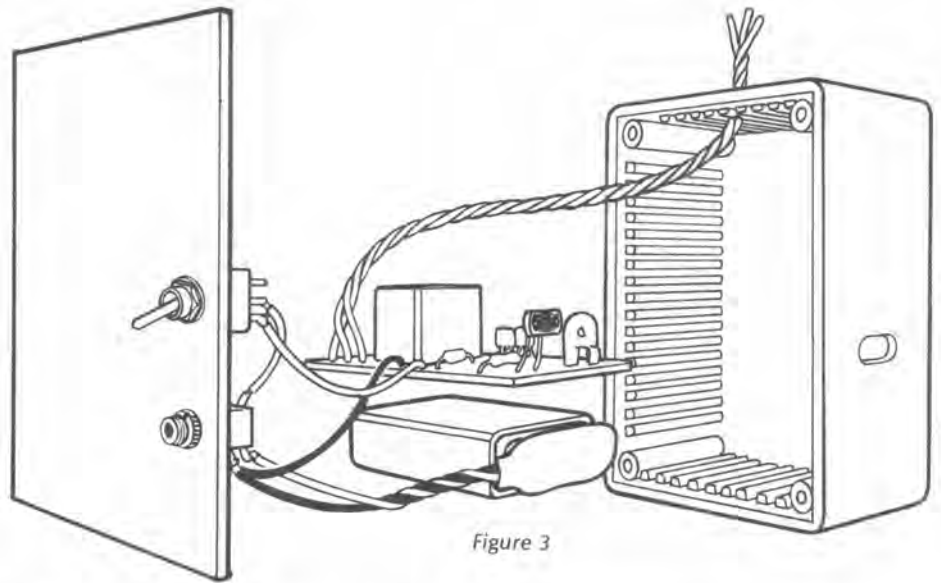

Figure 3

have a lot of fun experimenting with lenses and beams to get the greatest range: small lenses are usually available quite cheaply at disposals and hobby stores.

To obtain minimum false light entry into your 'beam' system, the LDR should be set well back into a light trap such as a cardboard tube painted black on the inside. In fact, the whole Zippy box can be mounted inside a

blackened tube!

The light source, too can be mounted in a light trap: this makes it much harder for anyone to see the light beam system – as you cannot see light, if you cannot see the light source you cannot see the system at all.

As a bonus, the light traps can often be used to support focusing lenses, too.

# how it works

A light dependent resistor has a very wide range of resistance – in bright light the resistance may fall to just a few hundred ohms (or less). In total darkness, the resistance is usually in the order of a few megohms.

We make use of this wide variation in our simple light activated switch.

Between the positive and negative supply there is a 'voltage divider'. As its name implies, a voltage divider simply 'taps off' a certain percentage of the voltage across the whole divider. A simple voltage divider consists of two resistors connected across a voltage source: the voltage at the junction of the two resistors can be set anywhere from the supply voltage to zero volts, by choosing the values of the two resistors.

For example, if a 1 ohm and a 9 ohm resistor were connected in series across a 10 volt supply, the voltage at the junction of the resistors would be 9 volts with the 1 ohm on top, but would be 1 volt if the 9 ohm were on top.

In the light operated switch, the voltage divider consists of two 'variable' resistors. The bottom one is RV1, while the top one is the LDR and R1. In fact, R1 doesn't have any part to play in the voltage divider: it is simply to limit current through the LDR and transistor to a safe value should the LDR's resistance fall to a very low level.

The voltage at the centre of the voltage divider (and, therefore, on the base of TR1) is dependent on the setting of RV1, and the amount of light falling on the LDR. In darkness or very low light, the LDR is a very high resistor, (much, much higher than RV1 even set at a maximum). So the voltage at the base of TR1 is too low to turn it on.

When the light level rises, and the LDR resistance falls, the voltage at this point rises. The point is soon reached where the voltage rises high enough to turn on TR1. RV1 can be adjusted to balance out some of the effects of the LDR, and so act as a level control.

Because the emitter of TR1 is connected directly to TR2's base, TR2 turns on, pulling in the relay. If the light level falls again, TR1 and TR2 turn off, and the relay drops out.

The diode connected across the relay suppresses any voltage 'spikes' which occur as the magnetic field surrounding the relay coil collapses. These spikes occur when the transistor turns off – the changing magnetic field (in this case a dying field) can induce high voltages across the relay coil. If not suppressed, these could damage the transistor.

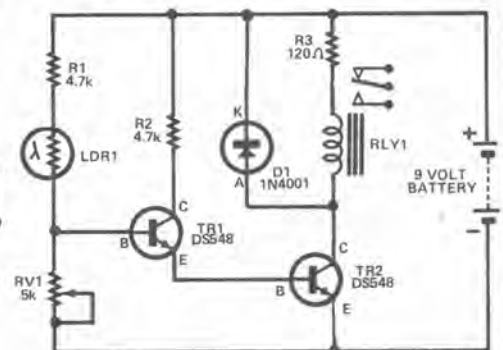

Figure 4

# working with Ohm's law . . .

Have all our circuit descriptions been a little too much for you? Do you understand Ohm's law, and how it helps us work out what is going to happen in a circuit? If not, read on: this page might help!

Back at the start of this book we briefly discussed Ohm's law (page 1). An understanding of Ohm's law puts you well on the way to understanding electronics.

To recap the Ohm's law formula:  
 $I = E/R$

where I is the current in amps, E is the potential difference in volts, and R is the resistance in Ohms.

Let's see what this means in a simple circuit (see figure 1).

The battery supplies 1 volt, and the resistor is 10 ohms. What is the current?

If you're any good at arithmetic at all, your answer should be 0.1A (or 100mA).

Now for an example a little harder. What is the current in the circuit of figure 2?

Did you get .004A (or 4mA)?

Ohm's law can be used 'backwards', too: Look at figure 3. We've put an ammeter in the circuit, and it tells us that 250mA is flowing. We know that the battery is 6 volts. What is the resistor value?

By moving Ohm's law around, we get  $R = E/I$ . This should give you an answer of 24 ohms.

Just to prove we're right, imagine the battery label just fell off. We know the current is 250mA and the resistor is 24 ohms. What is the voltage ( $E = I \times R$ ). Surprise, surprise: 6 volts!

What if we have two resistors in series, such as in the 'voltage divider' we talked about in the light activated switch. No problem! Look at figure 4a and 4b.

Because there is only one battery and one possible current path through the circuit, there can only be one current running in the circuit. And if the same current runs right through the circuit, the current through both resistors must be the same – even though the resistors are different in value!

We could, in fact, prove this with our meter. It could be placed anywhere in this circuit and would read the same as anywhere else!

So what is the current? That should be easy by now. Add both the resistors together: 10 ohms. Now if the supply is 10 volts, and the resistance is 10 ohms, the current is . . . . 1 amp, of course.

Now we know the current, what is the voltage across each resistor?

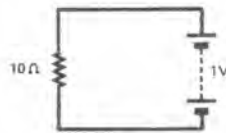

Figure 1

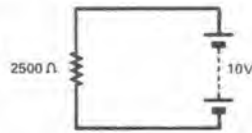

Figure 2

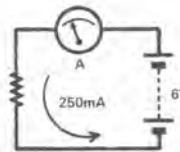

Figure 3

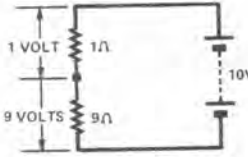

Figure 4

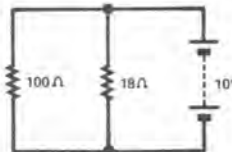
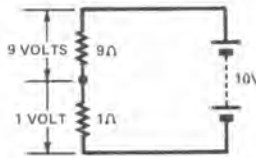

Figure 5



The circuits of figures 4a and 4b are classic voltage dividers: you can see how the voltage 'divides' across the resistors, in proportion to their resistance.

Suppose, however, that there was more than one path for the current to follow, such as in figure 5. Obviously, we could put an ammeter in each 'leg' of the circuit and measure the currents. But Ohm's law will tell us – and we can do it one of two ways. We can either work out the individual currents and add them together (0.55A through the 18 ohm and 0.1A through the 100 ohm, giving a total of 0.65A drawn from the battery), or work out the equivalent value of the two resistors in parallel (18 and 100 ohms in parallel is 15.25 ohms) and work it out that way. Do the calculation yourself using Ohm's law and see if the answer tallies.

How about a circuit with multiple branches. Can you work this one out?

All you do is reduce the circuit to a single resistor, by working out the resistors in parallel, and adding them to the resistors in series.

The various drawings of figure 6 show how this is done, step-by-step. And the current, which is what we wanted to know, is . . . . No, work it out for yourself. You should be able to by now!

And just to make life interesting, suppose we change Ra to 50 ohms, Rc to 120 ohms and place a new resistor, Rf, in parallel with the battery, of 33 ohms.

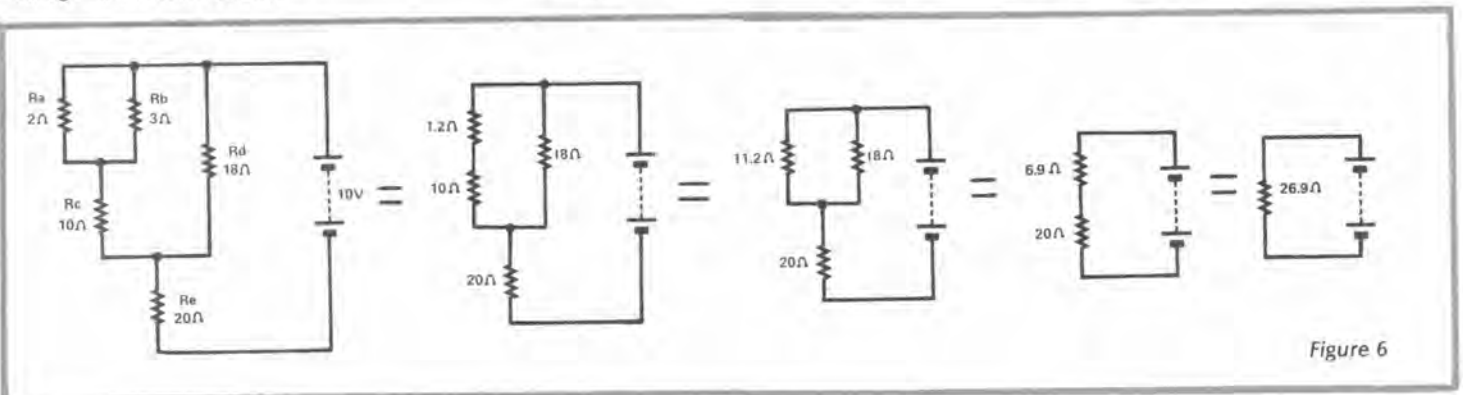

Figure 6

# project number thirteen

## Pipe and Metal Locator



With the price of gold now incredibly high, many people are spending hundreds of dollars purchasing metal detectors to go out and search for gold nuggets and other buried treasure.

Here is a simple metal locator which is extremely cheap to build, and very simple to use. It will detect small pieces of metal at depths of 8 to 10 mm – or large pieces even deeper. You could be lucky and find a fortune in gold just below the surface!

Apart from its treasure hunting aspect, this metal locator is a very useful handyman's aid, because it can be used to locate pipes and wiring, metal conduits, etc in walls or just below the ground.

This could save a lot of inconvenience by warning you of a pipe or cable before you dig – or before you drill into a wall through an electrical cable. It could even save your life!

### you will need these components

#### Resistors:

- R1 6.8k ohms
- R2 1.2M ohms
- R3 680k ohms
- R4 15k ohms
- R5 15 ohms
- RV1 5k ohm linear potentiometer

#### Capacitors:

- C1 0.1uF disc ceramic
- C2 390pF disc ceramic
- C3 0.001uF disc ceramic
- C4 0.01uF disc ceramic
- C5 0.0047uF disc ceramic
- C6 100uF 16V electrolytic

#### Semiconductor Devices:

- IC1 CD4001 CMOS quad 2-input NOR gate
- TR1 NPN type DS548 transistor or similar

#### Miscellaneous:

- L1 Approximately 18 metres of hook-up wire
- One magnetic earpiece
- Battery snap, solder, hook-up wire

You will also require a 9 volt transistor

battery (not normally supplied with a kit) or some other 9V DC power supply.

A suitable mounting board or printed circuit board of correct design (DSFW2 K-2633 Metal/Pipe Locator Kit contains the correct PCB).

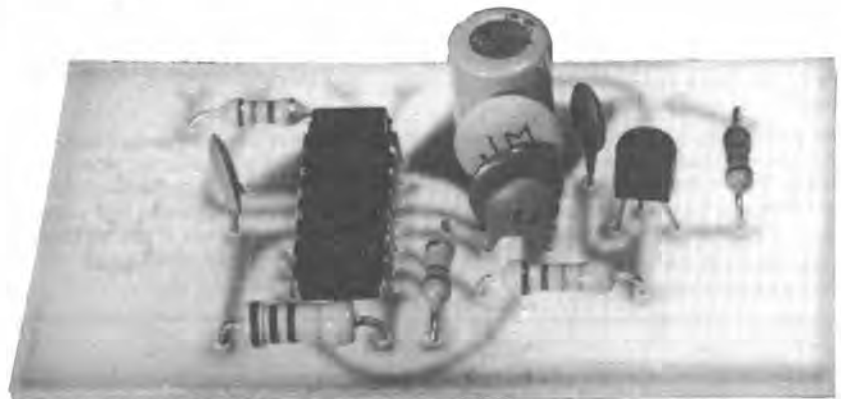

# putting it together

- (1) If you have purchased a kit (Dick Smith Cat. K-2633 or similar), check off the components against the above list to make sure they are all there and are the correct types and values.
- (2) If you have not purchased a kit you will need to obtain the components listed and either make a printed circuit board or use perforated strip board or similar, using the component position diagram as a guide.
- (3) Mount the components as shown in the component drawing – resistors and capacitors first taking extra care with C6 as it is polarised, (don't forget 'dress'). Then solder these in.
- (4) Solder in the transistor TR1, ensuring that it is the right way around and use a heatsink clip to prevent heat damage. Solder in the battery snap leads making sure they are the correct polarity, red to positive (+), and black to negative (-). And then solder in the magnetic earpiece leads.
- (5) Wind the 18 metres of hook-up wire around a suitable former approximately 100mm x 120mm, giving about 40 turns. Wind the wire firmly, but not so tight that you will be unable to take it off the former. Tape the coil with insulation tape, then solder the ends of the search coil to the board.
- (6) Use EXTREME CARE in the handling and soldering of the CMOS IC. Do not remove the electrostatic foam the IC is packed in until you are ready to place the IC in the board and solder it. Do not touch the pins of the IC under any circumstances and of course, be careful. Use a heatsink clip when soldering, and make sure the iron is properly earthed. As mentioned in other projects, it would probably be worth your while to solder in an IC socket or use Molex pins first. The reason we are using such an apparently delicate device is that it is a very efficient IC, doing the required job very well and using little power so that the battery will last much longer.
- (7) Clip off excess wire neatly, making sure that all of the soldered connections are properly made.
- (8) Check all components to ensure

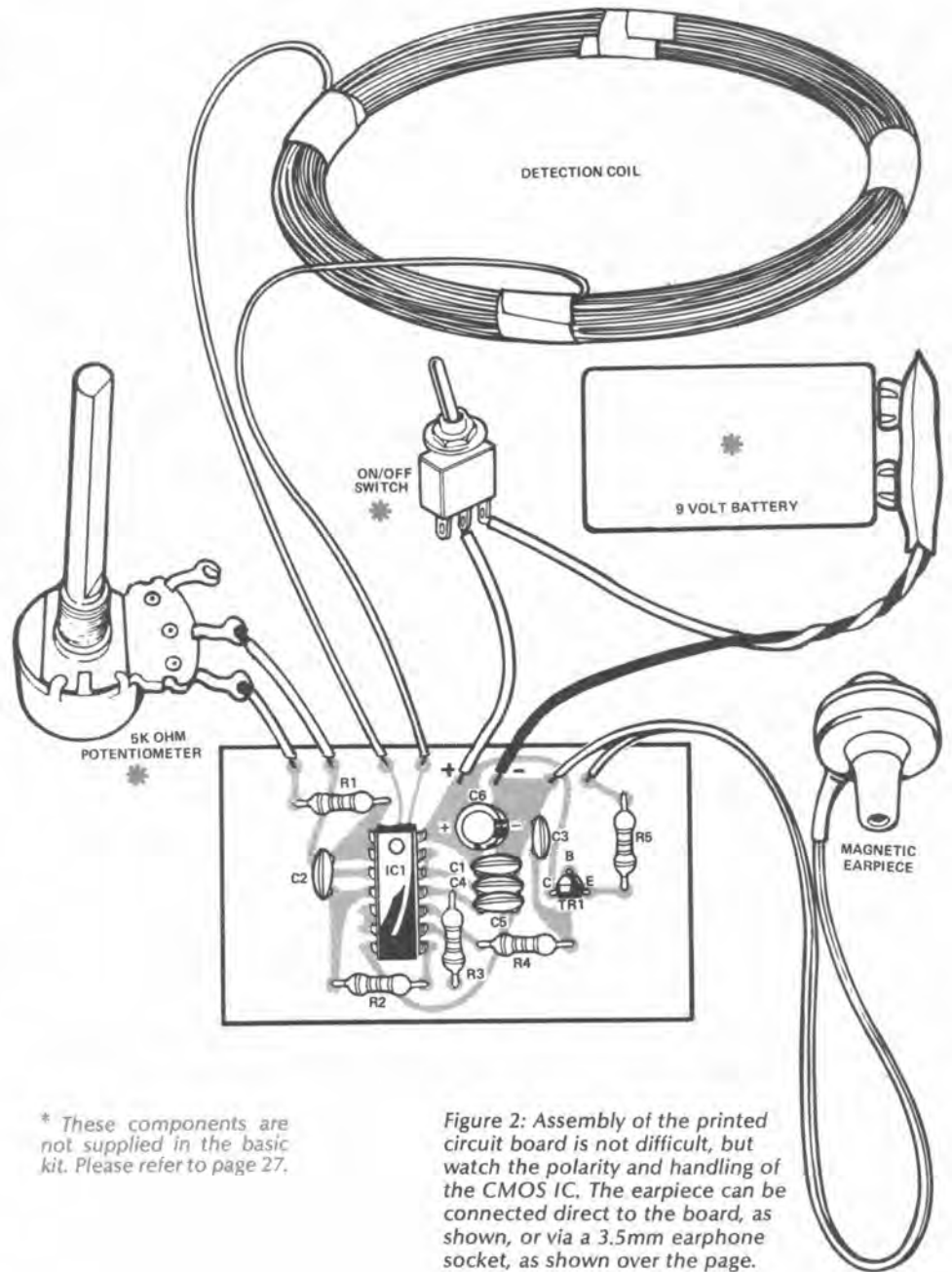

\* These components are not supplied in the basic kit. Please refer to page 27.

Figure 2: Assembly of the printed circuit board is not difficult, but watch the polarity and handling of the CMOS IC. The earpiece can be connected direct to the board, as shown, or via a 3.5mm earphone socket, as shown over the page.

that they are correctly positioned and oriented. Then connect the battery, and listen to the earpiece.

- (9) Adjust the potentiometer, and you should hear a number of whistles. By carefully adjusting the potentiometer until one of the stronger whistles is barely audible, you should find that a large variation in pitch occurs when the coil is brought into proximity to the metal.

# how it works

This metal detector works on the 'BFO' or Beat Frequency Oscillator principle. When the output from two oscillators is mixed together, two totally different frequencies are produced. One is the sum of the frequencies of the individual oscillators, the other is the difference in the frequencies. We make use of the latter: we 'beat' (another word for mix) the output from two oscillators to obtain the difference frequency: called the beat frequency.

Another factor we make use of is that the inductance of a coil changes if metal is brought within reasonably close proximity to it. You'll see how this helps us in a moment.

Inside the integrated circuit are four individual gates: they are drawn this way on the circuit diagram because they have no effect on each other. They can (and are), of course, be connected together externally to give certain functions. For convenience, we have labelled the four gates IC1a, IC1b, IC1c and IC1d.

To obtain a beat frequency, there must be two oscillators to beat against each other. In our circuit, IC1a and

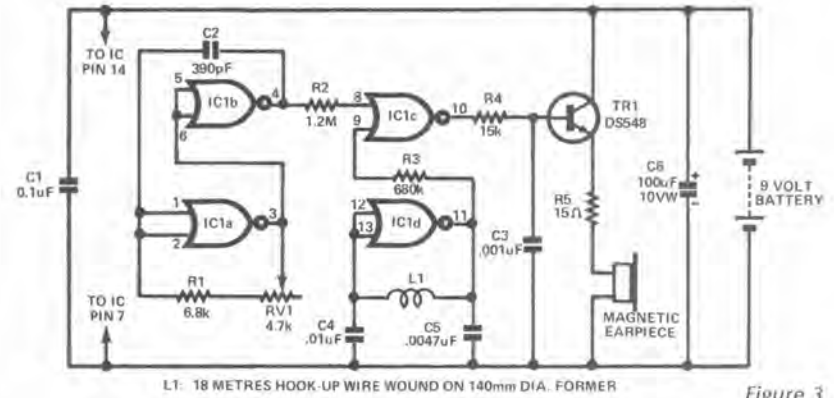

L1: 18 METRES HOOK-UP WIRE WOUND ON 140mm DIA. FORMER

Figure 3

IC1b, together with R1, RV1 & C2, form one of the oscillators. This is called the 'reference oscillator', and is variable over a small range by RV1.

The second oscillator is composed of IC1d, C4, C5 and L1 (the search coil). You've probably already guessed that changing the inductance of L1 (by bringing a piece of metal close to it) changes the frequency of this oscillator, called the search oscillator.

What happens is this: the search oscillator oscillates at a certain frequency. The reference oscillator beats against this frequency to

produce a beat frequency. Now if a piece of metal is brought near the search coil, the search oscillator frequency changes, and so does the beat note.

The output frequencies of the two oscillators are beat together by IC1c, producing an audio frequency signal at its output. This is fed, via R4, to TR1 which amplifies it in level enough to be heard through a magnetic earpiece. C3 filters out any high frequency component from the signal which might only cause inefficiencies in the amplifier.

# what to do next

To protect the printed circuit board and components from damage, they should be mounted in some form of protective case. Once again, the printed circuit board has been designed to fit into a slotted Zippy box, with no need for any mounting holes on the PCB.

As shown in figure 4, the potentiometer, on/off switch (if you are fitting one) and the earphone socket are mounted on the front panel of the zippy box. In the back of this book you will find an attractive label to glue to the front panel to give your metal detector a really professional look.

Because this project is not likely to be

used with a plug-pack adaptor, we have not shown one connected. However, if you wish to include provision for a plug-pack adaptor, it is easy to wire in the socket: follow the wiring diagram for any project which includes a plug-pack socket. (The socket goes in series with the positive lead of the battery – the red lead).

The wires to the search coil are not connected to a socket, instead they pass directly through a hole in the side of the box and away to the search coil.

The coil itself deserves special treatment. As the quality of the coil is, like all metal detectors, the one factor

which most determines performance, it should be carefully made, and then mounted on some type of former for mechanical protection.

You can choose yourself the complexity of the coil former: it could

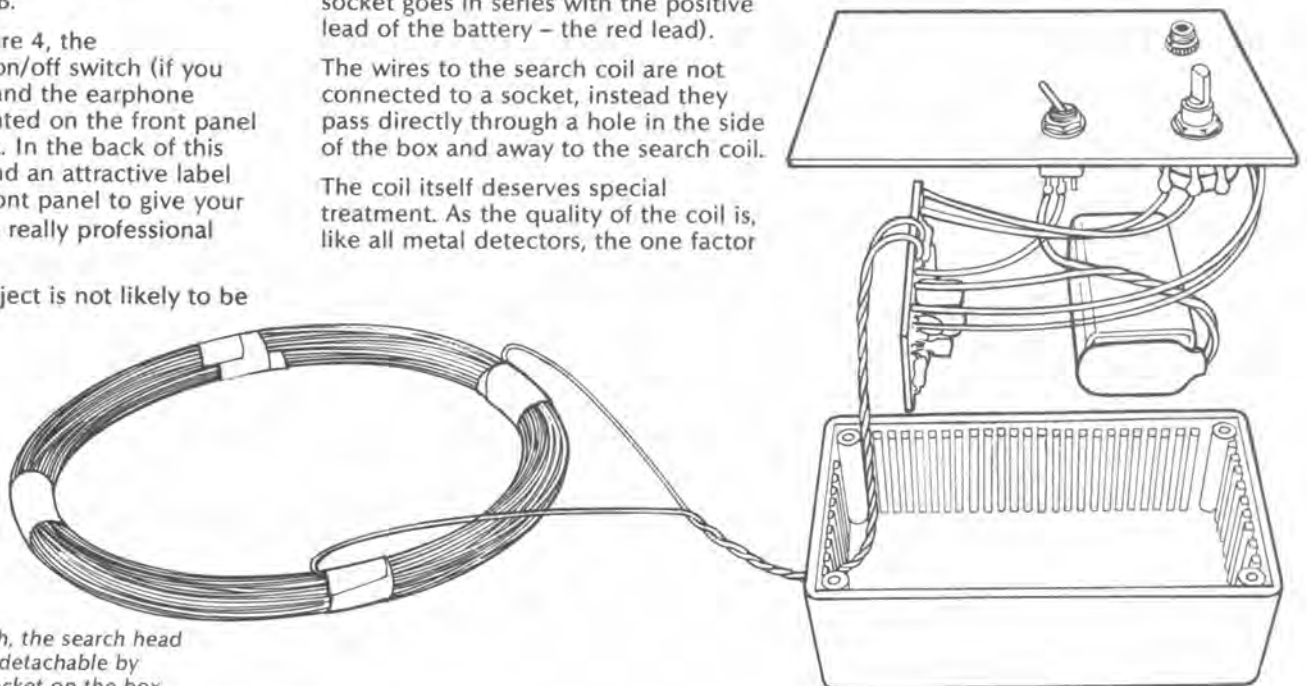

Figure 4: If you wish, the search head may be made fully detachable by using a plug and socket on the box.

## putting it together . . . continued

be as simple as a piece of flat cardboard with the coil glued or sticky-taped to it. Or it could be a plastic dish a little larger than the coil, with the coil glued in or even 'potted' with potting compound, as we discussed for electronic jewellery.

Whatever former you choose, however, one thing is very important: it must not be made of, nor contain, any metal. This even applies to such things as nails and screws which might be used to hold it together. Any metal will detract from the performance of the detector.

As we have shown in the drawing at the start of this project, the coil (in its former) can be connected to the zippy box by a length of plastic or wooden dowel. This can be made any convenient length, and if you wish, the coil can be angled to allow easiest use of the detector. Once again, keep all metal away from the coil: use tape or glue to hold it together.

Figure 5: The assembled metal locator. Make sure you heed our warnings about using metal anywhere in the vicinity of the search coil!

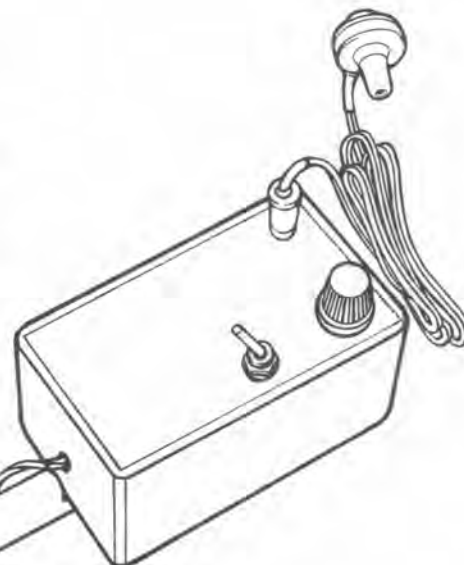
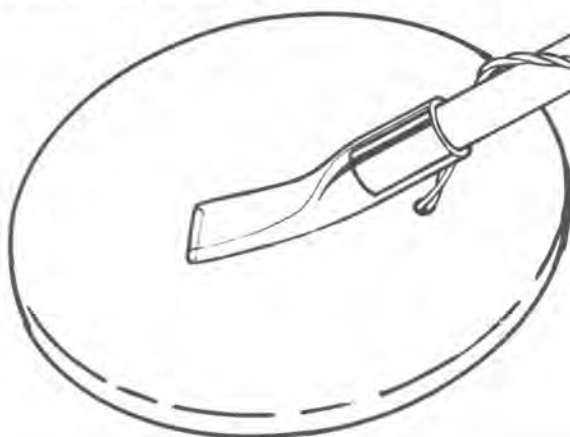

### Using your metal locator

Once assembled, you can try out your pipe and metal locator. Listen for a good strong whistle as you vary the potentiometer over its range. Adjust the potentiometer so you can just hear the whistle. The locator is at its most sensitive in this mode.

Now move the search coil towards a metal object. You should hear the tone change one way or the other, depending on where the pot is set. If you leave the pot set at the same position, and move the search coil over a piece of non-ferrous metal, the tone should drift in the opposite direction to when you move the search coil over iron or steel.

## Vladimir Kosma Zworykin (1889 - )

Regarded by many as "The Father of Television".

Born in Russia, Zworykin's early education was at the Petrograd Institute of Technology. He later studied in France before moving permanently to the U.S.A. in 1919.

During this period he worked for the giant Westinghouse Corporation. While there he developed a device which he called an Iconoscope. This was the first electronic camera tube. In other words, it was the first device capable of turning a picture into an electrical signal electronically.

He quickly followed-up this with the other important half - a TV picture tube which he called the Kinescope.

Thus Zworykin invented the two most important devices that made modern TV possible. All other aspects of TV i.e. scanning, synchronisation, transmitting, receiving etc were basically applications of existing theory at the time - clever as they were (and are).

Zworykin moved over to R.C.A. (Radio Corporation of America) in 1929 to become director of their electronic research team which not only produced the Electron Microscope but developed it to a point where it could be used

by research organisations.

During WWII he worked on many military related projects as well including infra-red night seeing devices (for snipers etc) and guided missile electronics.

Whilst in his 90's today he still actively corresponds with other men of science.

**Footnote:** "Television" was not actually invented by any one person.

The concept of 'Pictures over Wires' (and subsequently wireless) was quite old even before the turn of the century.

Alexander Graham Bell (the inventor of the telephone) tried as long ago as 1876.

Most early attempts at a television system however, were electro-mechanical - possibly following a line of reason developed from motion (film) pictures which are mechanical by nature.

Among the early pioneers are Paul Nipkow (1884) - mechanical; Alan Archibald Campbell-Swinton (1908) - electronic; Boris Rosing (1907) - mechanical and John Logie Baird (1925 onwards) - mechanical.



Baird's efforts stand out because of the number of technical achievements, however he really cannot be regarded as the "inventor" of television for two reasons.

(i) He appeared to be more interested in establishing the technical feasibility of his system rather than refining it for actual application.

(ii) His system was basically mechanical by nature and was technically headed for a dead end.

Notwithstanding this, his contribution is so great he stands shoulder-to-shoulder with Zworykin.

Zworykin just happened to pick the right horse.



# project number fourteen

## Sound Switch

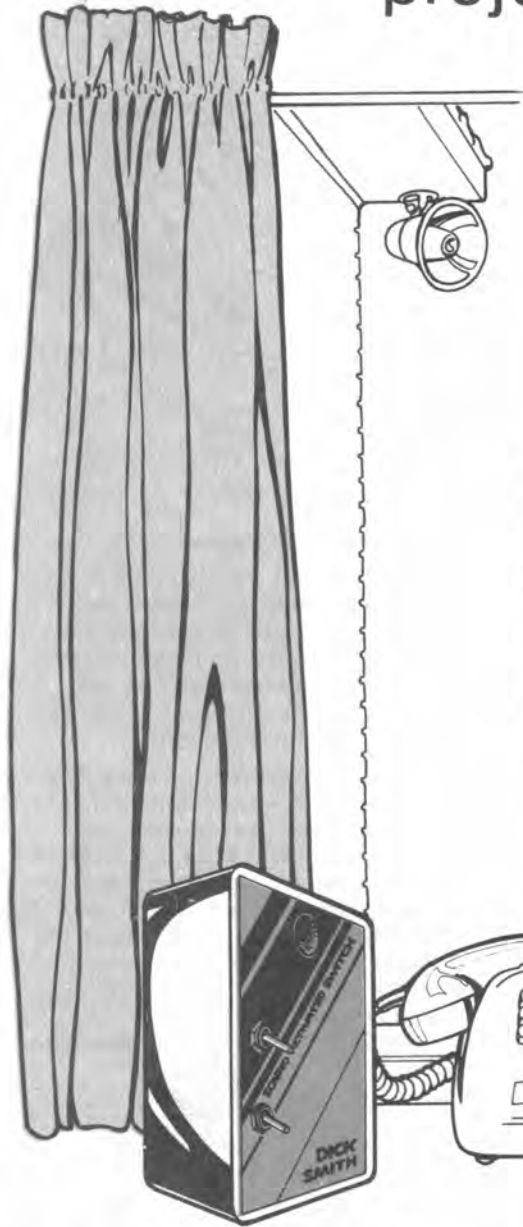

Imagine: you come home late one cold and rainy night, drive up to your garage door and honk the horn. Just as if you had a servant or a genie, the door opens! You get out of the car, and clap your hands: and the door closes! It's all possible with our sound operated switch. You can set it for alternate operation, as above (first sound open, second sound closed); or you can have it operate each time a sound is received, then revert back when the sound stops. Just as our illustration shows, this could be a telephone bell extender – without any connection to the phone or wiring (which is illegal). There are dozens of ideas you could try with this sound operated switch: all you have to do is build the project!

### you will need these components

#### Resistors:

R1	3.3k ohms
R2	100k ohms
R3	150k ohms
R4	10k ohms
R5	47 ohms
R6	33k ohms
R7	10k ohms
R8	47k ohms
R9	4.7k ohms
R10	390 ohms
R11	120 ohms
R12	1k ohms

#### Capacitors:

C1	0.1uF polyester (greencap)
C2	10uF 16V electrolytic
C3	10uF 16V electrolytic
C4	4.7uF 16V electrolytic
C5	220uF 16V electrolytic

#### Semiconductor Devices:

TR1	DS548 transistor or similar NPN type.
TR2	DS558 transistor or similar PNP type.
TR3	DS548 transistor or similar NPN type.
TR4	DS548 transistor or similar NPN type.
D1, D2, D3, D4	1N4001 diodes
IC1	7473 flip-flop IC

#### Miscellaneous:

RLY1	9-12 volt relay
	One condenser microphone insert.
	Battery snap, solder, hook-up wire.

You will need a 9 volt transistor battery (not normally supplied with the kit) or a 9 volt plug-pack mains adaptor. You will also require a single pole change-over switch (any type) if you want both modes of operation (see text).

A suitable mounting board or printed circuit board of correct design (DSFW2 K-2634 Sound Activated Switch Kit contains the correct PCB).

# putting it together

- (1) If you have purchased a kit (Dick Smith Cat. K-2634 or similar), check off the components against the above list to make sure they are all there and are the correct types and values.
- (2) If you have not purchased a kit you will need to obtain the components listed and either make a printed circuit board using the component position drawing, or use perforated strip board and the component position drawing as a guide.
- (3) Mount the components as shown in the component position diagram – resistors and capacitors first (don't forget 'dress'). Then solder these in.
- (4) Position the relay using the five pin configuration as a guide and solder in.
- (5) Position and solder the diodes D1, D2, D3, and D4 and transistors TR1, TR2, TR3 and TR4, being very careful to ensure that you have the right transistors in the right place and

the correct polarity. Remember, one is a PNP and three are NPN transistors. Solder carefully, using a heatsink clip to prevent damage from overheating.

- (6) Very carefully position IC1 (the notch is between pins 1 and 14) and solder it in. Use a heatsink clip and take care not to overheat the IC. As mentioned in the **Touch Switch** description it may be easier for you to solder in an IC socket or Molex pins and then plug in your IC when soldering is complete.
- (7) Solder the wires in for the switch to set mode of operation, if you are fitting one. Any type of single pole change-over switch can be used in this position. Alternatively, if you do not want both modes of operation, a wire link can be used to give one mode. Solder the link between the right-hand pad of the three 'switch' pads and the left pad for 'on with sound only' mode or the centre pad for 'alternate

on/off' mode.

- (8) Solder the electret microphone connections to the board and then the battery snap leads. Make sure the battery lead colours are correctly polarised – red to positive (+) and black to negative (–).
- (9) Clip off all excess wire neatly, making sure that all of the soldered connections are properly made.
- (10) Check all components to ensure correct position and polarity before connecting the battery.
- (11) Connect the battery and speak into the microphone – this should cause the relay to operate and hold 'ON' if you have IC1 in circuit. If not RLY1 will drop 'OFF' as soon as you stop speaking. If IC1 is in the circuit it will hold on while silence persists and drop 'OFF' at the next sound.

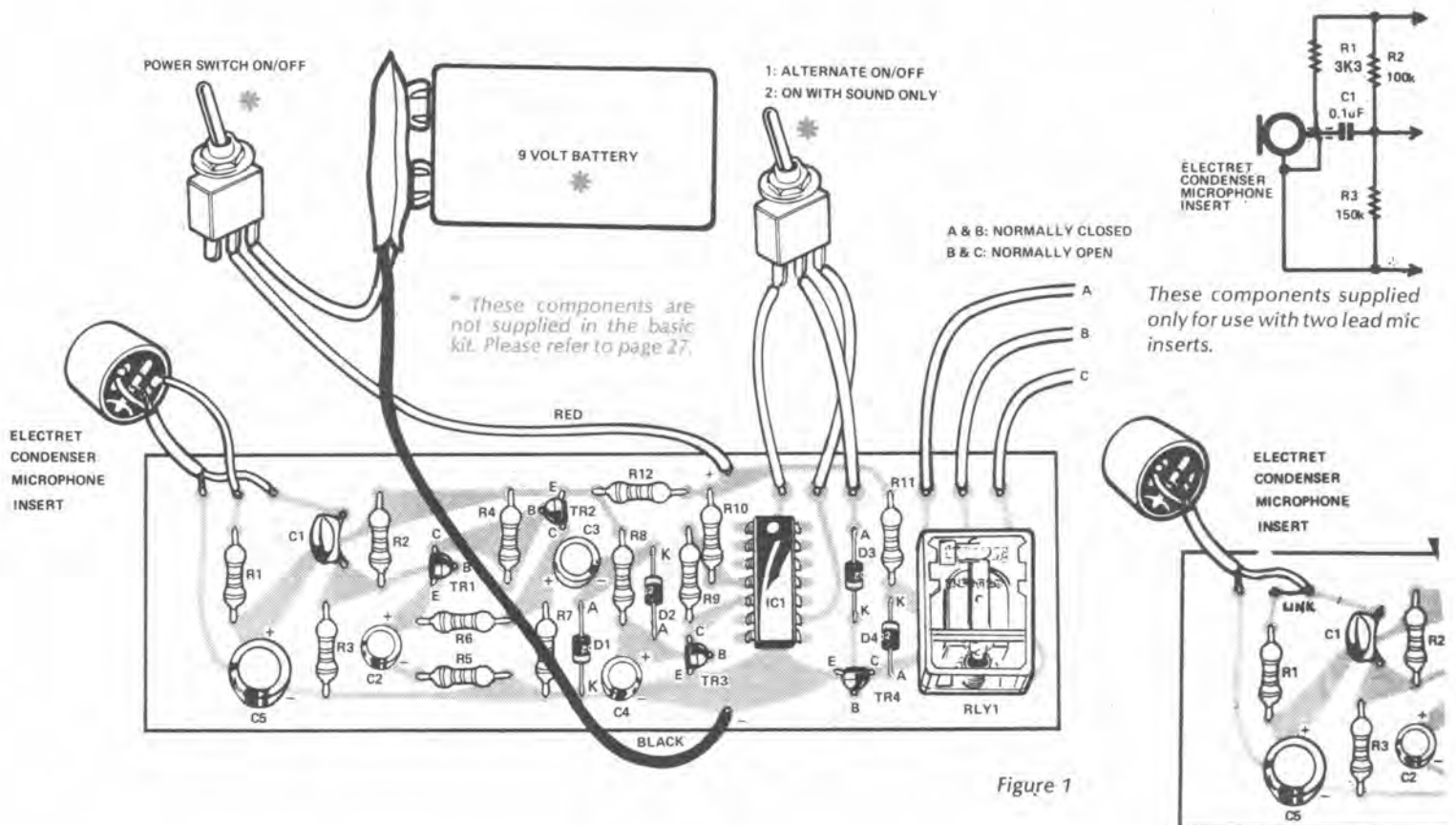

Figure 1

P.C.B. Layout for two lead mic inserts.

# how it works

Like most circuits, the operation of the sound operated switch can be most easily understood by breaking the circuit down into a number of sections, and considering what effect each section has.

Let's start with the 'output' of the circuit: the relay and its driver transistor, TR4. Fairly obviously, this is a standard switching circuit: when TR4 is turned on, the relay pulls in.

TR4 can get its drive from two sources – this depends on the setting of the switch, SW1.

If the switch is in the No. 2 position, TR4 is connected (via D3) to TR3's collector. TR3 is normally turned on by R8, so its collector voltage is normally low and TR4 does not receive any drive. It is only when TR3 turns off (and its collector voltage rises) that TR4 can turn on.

If the switch is in the upper position (No. 1), the Integrated circuit, IC1, is switched in. This integrated circuit is very much like the multivibrator we

built in project one. It does not oscillate of its own accord, however; instead it switches back and forth between its two states each time a triggering voltage is fed into its input circuitry.

This triggering voltage also comes from the collector of TR3. Each time the transistor is made to turn off, the change in voltage triggers the IC. The first triggering voltage might cause the output to go high, (turning on TR4 and pulling in the relay). The second triggering voltage might cause the output to go low (dropping out the relay). The third high again, and so on.

Looking now at the front end of the circuit, TR1 and TR2 are simply amplifiers which increase the level of the tiny electric currents generated when sound waves strike the microphone. The audio signal is then fed into a rectifier circuit (consisting of D1/D2/C3/C4) which changes the audio signal (AC) into direct current (DC).

Actually, the rectifier is a rather special type because it not only changes the AC to DC as a normal rectifier does, it also adds the positive and negative halves of the AC signal together to produce a rough DC voltage nearly double the AC input voltage. This configuration is called a voltage doubling rectifier.

Because of the way the voltage doubling rectifier components are connected, the DC voltage produced is negative with respect to the negative supply.

So when sound waves strike the microphone, a significant negative voltage is fed into the base of TR3. This over-rides the positive voltage which was holding TR3 on, so it instantly turns off. The collector voltage increases sharply, and this is used to either switch TR4 directly, or trigger the IC, as we explained earlier.

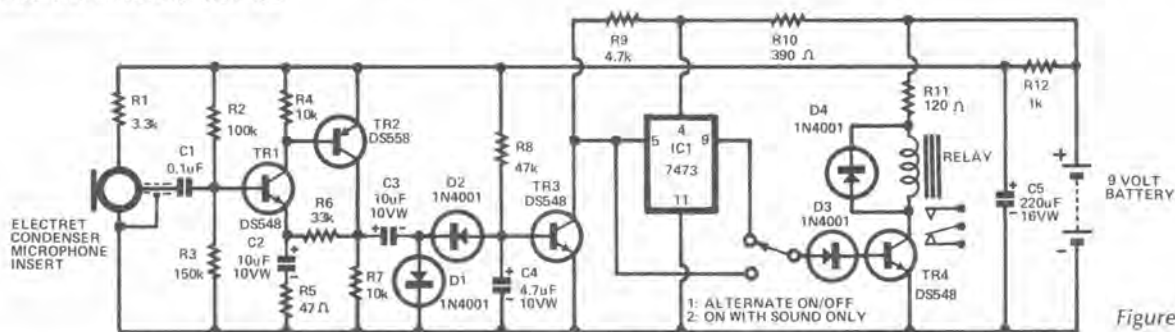

Figure 2

# what to do next

Most constructors will want to protect the PCB by mounting it in a protective case. As usual, we have designed the pcb for easy 'no holes' mounting in a slotted Zippy box (Dick Smith Cat No. H-2753). The pcb slides in sideways, as shown in the accompanying drawing. The microphone and switch(es) mount in the front panel. A drilling template is provided for this, as well as an attractive label to glue to the Zippy box lid.

Of course, the microphone insert does have to be held securely. A couple of drops of superglue will hold it if the hole is drilled to the right size. You don't **have** to mount the insert on the front panel: the leads can be lengthened to allow the insert to be remotely located if you wish. Make sure that you use shielded cable for the audio connection to minimise false triggering from electrical noise. In the electret normally supplied, a piece of shielded lead is used for the audio, and ordinary hookup wire is

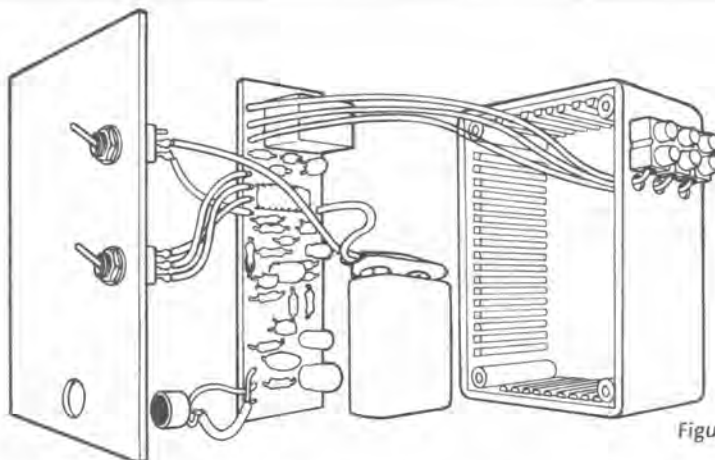

Figure 3

used for the 'power' lead. This can be duplicated for longer lengths, but to make things neat, you could use a shielded twin conductor lead (Dick Smith Cat No W-2034 or similar) and use one of the internal leads for audio, and one for power. This saves having two different cables running to the insert.

As the sound operated switch uses a

relay, it does draw a fair current from the battery. If you are using the project for any length of time, it would pay you to fit a 3.5mm socket for an external plug-pack adaptor. As always, wire the socket exactly as shown in project one and elsewhere through this book.

Another tip you will find useful is to terminate the three leads from the

## what to do next . . . continued

relay (N.O., N.C. and common) in a three-way terminal block, mounted near the top of the Zippy box. This makes connection to the circuit much easier. Label the three terminals so you know which one is which!

### An extension telephone bell

Current Telecom regulations do not allow the handyman to fit an extension bell to a phone. Instead, Telecom do it and charge a rental. The sound operated switch can pick up the ring of the phone and simultaneously ring another bell elsewhere in the building or yard – without infringing any regulations.

All you need do is locate the sound operated switch very close to the telephone (the best position is to have the 'phone right on top of the box).

Your extension 'bell' is connected to the 'N.O.' contacts of the relay. For safety's sake you should use a low voltage bell. Bells suitable for this role are quite common; you should be able to pick one up at a disposals store for a reasonable price.

Alternatively, you could use the siren or ding-dong doorbell projects from this book, with a horn speaker. That would **really** be an unmistakable phone bell!

### Using your sound operated switch for photography

For those interested in photography, a sound operated switch can be the key to some incredible action shots. Think of the sounds that occur when things happen: a glass breaking, for example. With the sound operated switch, you can take a photo of it actually happening!

The secret behind this type of photo is that it is taken in the dark: with the camera shutter held open, the sound actually triggers a flash which 'takes' the picture.

You will need a camera with a flash gun which can be connected via a lead (or else you will have to connect to the 'hot shoe' terminals of the flash). Your camera must also be capable of having its shutter locked open.

The flash firing lead (or hot shoe connection) is attached to the 'N.O.' contacts of the relay in the sound operated switch. When the relay closes it fires the flash. It doesn't matter if the flash is a bulb, cube or electronic type; the only problem with an electronic type is that any other noise might trigger the flash again before the shutter is closed.)

Set up your camera securely (preferably on a tripod) and select the appropriate aperture, focus, etc, before turning the lights out. Open the shutter and lock it. When the noise triggers the flash, the scene at the particular moment is captured.

In fact, there is a tiny delay between the time of the noise and the time the relay contacts are closed. This is often an advantage, for it gives the action time to happen. For example, the bulb striking the floor makes the noise: if the flash went off then it would just be a photo of a bulb. Moments later, the glass starts to break up. **That** is the best time to take the photograph.

Figure 4: This is what your assembled PCB should look like. Compare this to the pcb layout diagram.



## Milestones in Electronics

### The Phase-Locked Loop c. 1932

Although invented quite a while ago now, the Phase-Locked Loop (or PLL as it is popularly known) has only recently come into very common use. The advent of the Integrated Circuit (IC) has enabled this useful circuit to be used in applications that were otherwise uneconomical or inconvenient.

The circuit consists of a Phase Detector, Bandpass Filter, D.C. Amplifier and Voltage Controlled Oscillator (V.C.O.).

The V.C.O. runs at a frequency close to that of the incoming signal. The Phase Detector provides a voltage if the V.C.O. and input signals are different. This 'error voltage' passes through the filter and is amplified as a DC voltage and applied to the V.C.O. causing a change in frequency of the V.C.O. The object of course, is to get the V.C.O. and input frequencies to 'lock' together.

The self-stabilising characteristic of this circuit makes it ideal for high stability oscillators, as well as other applications such as F.M. demodulators (detectors) etc.

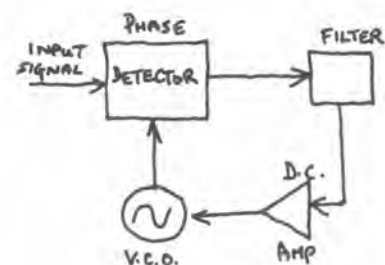

# project number fifteen

## Home and Car Alarm

**Crime is on the increase! Over 50,000 cars are stolen and more than 100,000 homes are illegally entered in Australia each year!**

**This project could stop yours becoming the next target on the list! It is very easy to build, and should prove very reliable. It has features found in professional alarm systems costing hundreds of dollars.**

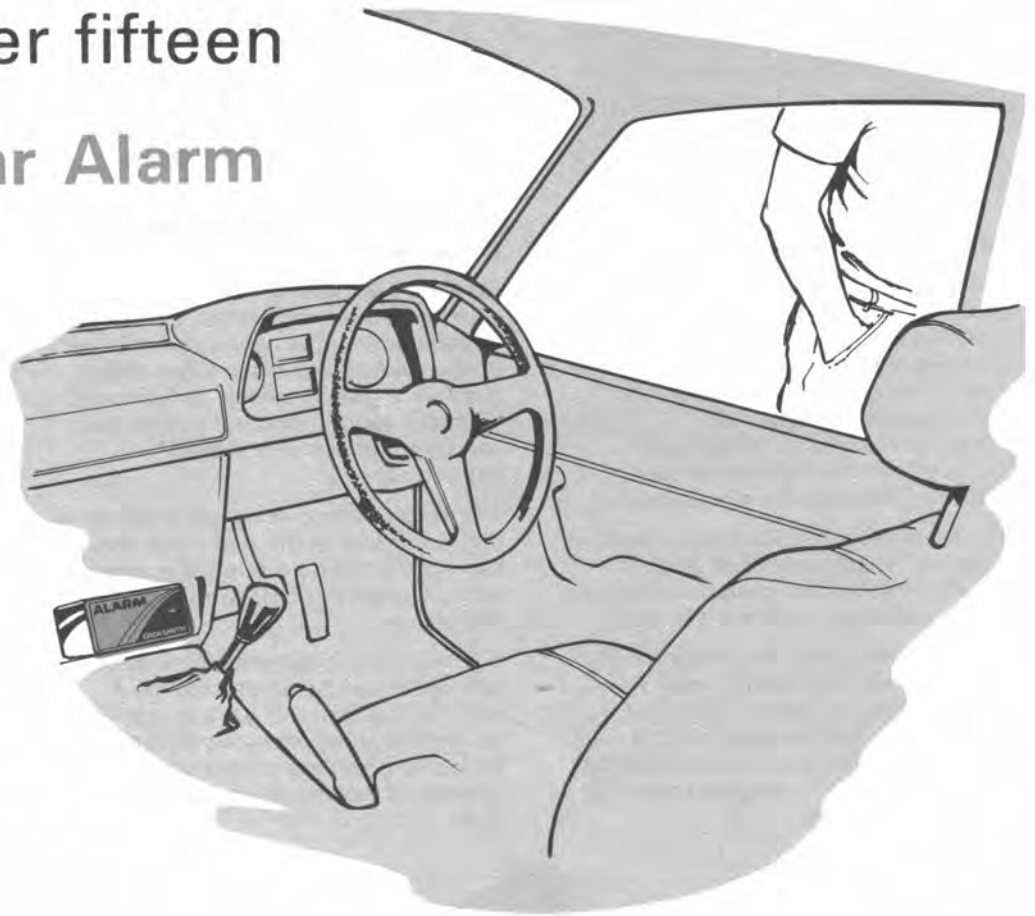

This alarm is very simple to build and operate, because it is controlled by a key switch (Dick Smith Cat No L-5290 or similar) – it doesn't have complicated timing circuits and setting procedures like many other alarms.

A key switch looks just like the ignition switch in a car: you turn the key one way and the switch is on; back the other way and the switch is off. Key switches are normally installed on or near the front door of the house or, in the case of a car, on the door or mudguard.

Inside the house, connected to any vulnerable door or window, are sensor switches which detect any opening. The sensors are usually 'magnetic reed switches' (Dick Smith Cat No. L-5210 or similar) which we'll explain later.

When you leave the house, you check that all necessary windows and doors are closed, then turn your key in the switch. The circuit is then 'armed', ready to detect any intruders. The main alarm circuit is a 'normally closed' type which means that a small current flows through the sensors whenever the alarm is armed. If any of the sensors are opened, or if the intruder tries to cheat by cutting a wire, the alarm triggers instantly. Any warning device connected (such as a bell, siren module, etc) sounds for around five minutes, after which time it turns off and the circuit re-sets (so your neighbours aren't annoyed by the noise!)

There is a secondary 'normally open' circuit, in the alarm, so that you can use under-carpet pressure mats, bedside panic switches, etc, should an intruder have gained entry by a method which didn't trigger the door or window switches.

A further feature of this alarm circuit is that it operates normally from the mains supply via an adaptor. However, should an intruder turn off the mains at the fuse box to try to defeat the alarm, a battery stand-by circuit comes into action. So the alarm cannot be disabled: only the legitimate user can turn it off via the key switch.

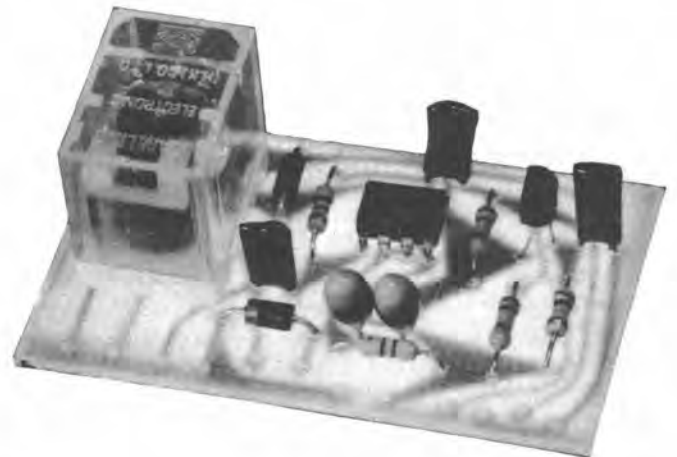

Figure 1

# you will need these components

## Resistors:

- R1 220k ohms
- R2 100k ohms
- R3 4.7M ohms
- R4 100k ohms
- R5 47k ohms

## Capacitors:

- C1 .01uF polyester (greencap)
- C2 .01uF polyester (greencap)
- C3 22uF 16V tantalum electrolytic
- C4 22uF 16V tantalum electrolytic
- C5 .01uF polyester (greencap)

## Semiconductor Devices:

- D1 1N4002 diode
- D2 1N4002 diode
- TR1 NPN transistor DS548 or similar
- IC1 555 timer integrated circuit

You will also require a 9 to 12 volt battery of reasonable capacity (two 9V alkaline batteries in parallel, for example) or some other 9 – 12 volt supply (not normally included in the kit).

A suitable mounting board or printed circuit board of correct design (DSFM 2 K-2635 **Home Alarm/Car Alarm** kit contains the correct PCB.)

# putting it together

- (1) If you have purchased a kit (Dick Smith Cat. K-2635 or similar), check off the components against the above list to make sure they are all there and are the correct types and values.
- (2) If you have not purchased a kit you will need to obtain the components listed and either make a printed circuit board using the component position drawing as a guide, or use a perforated or tracked board.
- (3) Mount the components as shown in the component position drawing. Place and solder the resistors and capacitors first taking extra care to mount C3 and C4, the two tantalum capacitors, the right way around as they are polarised. The small '+' sign marks the positive lead positions on the prototype but the method of designation could change. Look in the **Components** section for further information. Check that all the components are positioned neatly and correctly 'dressed' before soldering them in.
- (4) Position and solder RLY1 after ensuring that you have it correctly oriented. This is simplified by the fact that the five pins will only line up one way.
- (5) Next, position the diodes D1 and D2 taking care to see that they are correctly polarised. Remember, the cathode (K) is the banded end and corresponds to the bar in the circuit diagram. Solder them in taking care not to overheat them.
- (6) TR1, the NPN transistor, is next and care must again be taken to ensure correct polarity with the base connecting to C1 on the PCB. Solder the transistor in using a heatsink clip to prevent damage from overheating.
- (7) The 555 timer integrated circuit, IC1, is the last component to be placed and soldered. It is done last to reduce the risk of damage from overheating. Follow these steps each time you place an IC to reduce the chances of error and damage to the device. Insert the integrated circuit into the holes on the PCB until the

*Continued overleaf*

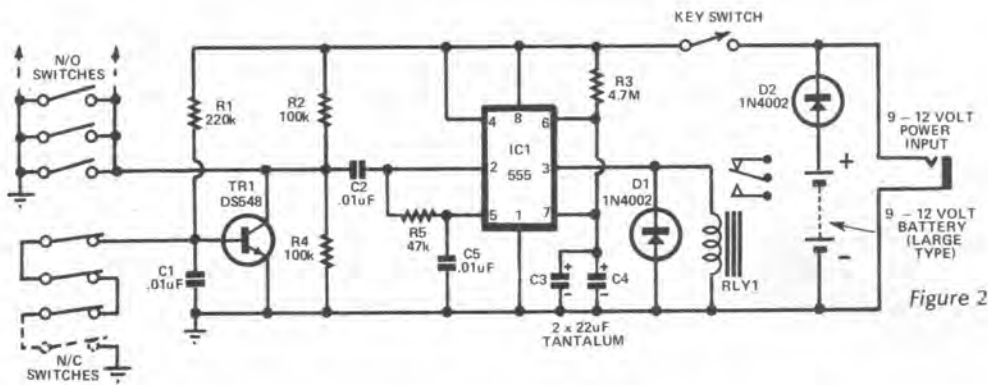

Figure 2

Above: the circuit diagram for the complete home alarm system, showing connection points for the normally open (N.O.) and normally closed (N.C.) switches. The choice of alarm warning device is left to you: a large bell, a siren, etc can be switched by the relay on the alarm PCB.

Right: The component positions on the printed circuit board. Connections to the pcb are shown in detail overleaf. Note particularly the orientation of D1 & D2, IC1 and TR1, plus the two tantalum capacitors.

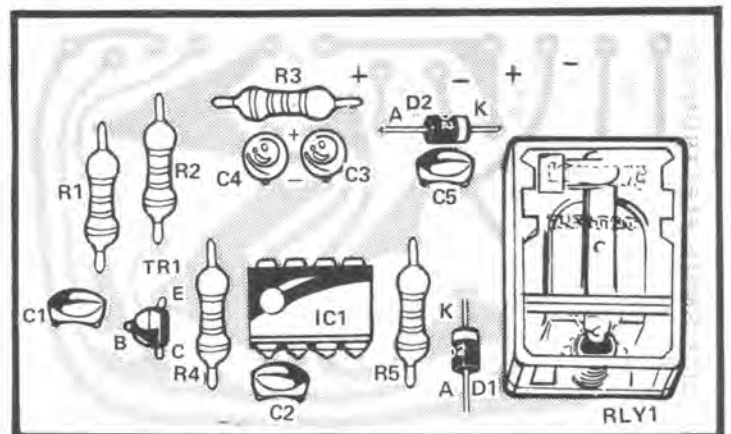

Figure 3

# putting it together

## ... continued

little shoulders on the pins prevent it from going further: make sure it is the right way around, by noting that pin 1 (the one marked with the circle indented into the top of the IC) is connected to the negative track; then turn the board over and carefully solder each of the pins to the pads making sure that you don't run solder between

the pads. See **How to Solder** for hints on making correctly soldered joints. Inspect the connections to make sure you've soldered them all without shorting out any of the pads and that's it!

- (8) Solder on the battery snap wires, taking care to see that they have the correct polarity – red (positive) to the pad marked '+' and black to the negative pad marked '-'.
- (9) Before you connect the battery check again that all the

components are in the right place, the correct polarity and soldered properly. Clip off any excess wire and leads.

- (10) Connect the battery and test the circuit by bridging the key switch pads. This should cause the relay to operate as the normally closed (NC) contacts would still be open (we haven't connected them yet). The relay will stay operated for about 5 to 7 minutes and then relax if the circuit is working correctly.

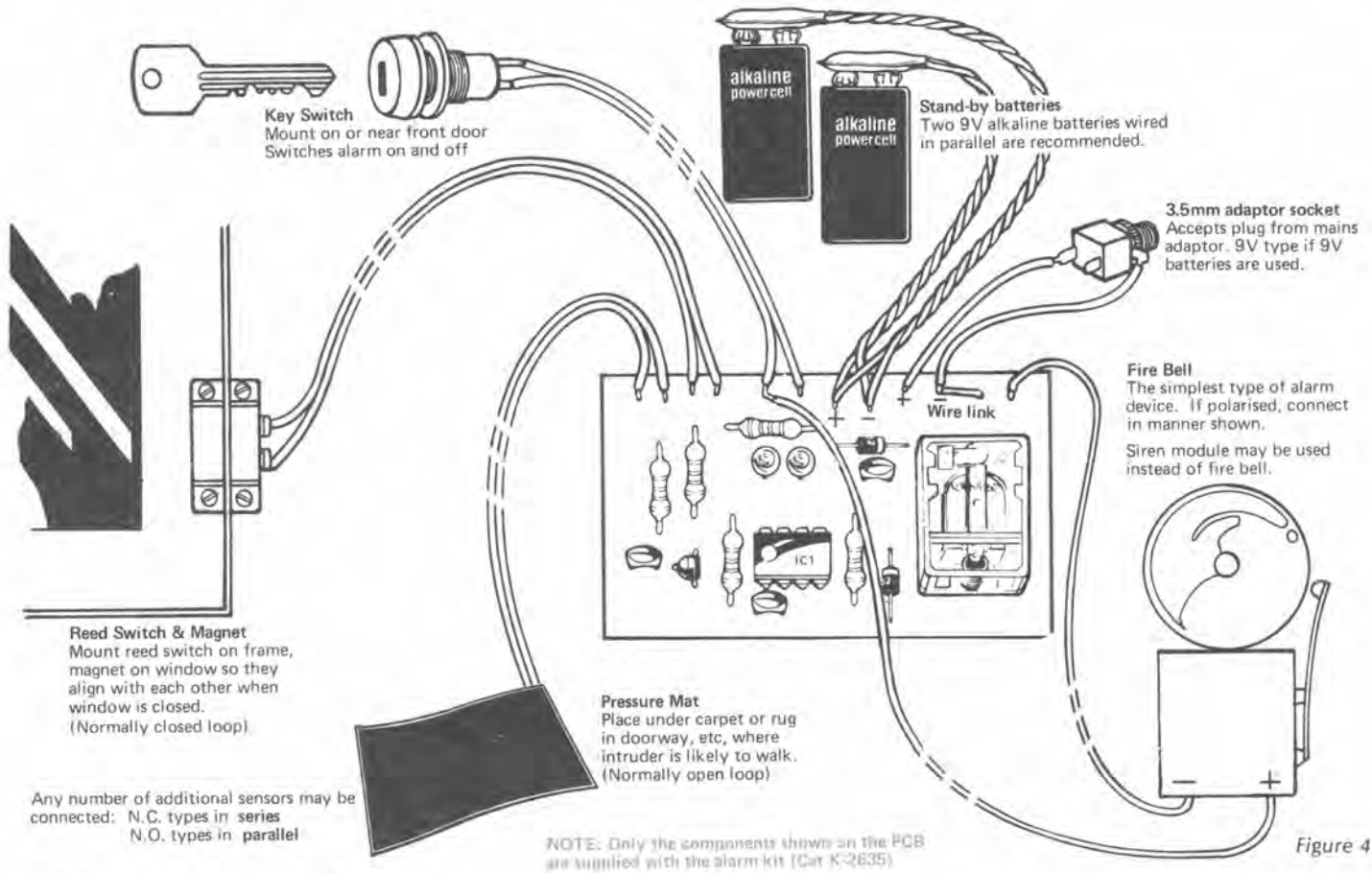

Figure 4

Above: This is the way the printed circuit board is connected to all the 'peripheral' devices mentioned in the text. Obviously, the wires to these devices may be as long as required, and any number of sensing devices may be connected to the N.O. and N.C. terminals: just remember that N.O. devices connect in parallel; N.C. devices connect in series.

Right: For easy connection, the home alarm pcb can be mounted in a box with terminal strips mounted on the lid, as shown. This makes connections (as shown above) very easy indeed. There is plenty of room inside the box for a pair of 9V batteries, if required.

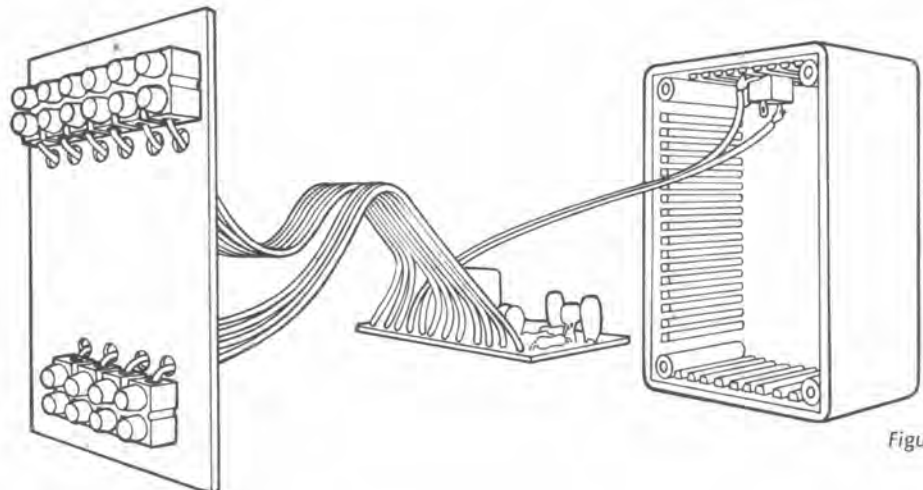

Figure 5

# what to do next

First of all, you must decide which use your alarm is going to be put to: a home alarm system or car alarm system. Different connections are required for each purpose.

## Home Alarm System

First step is to build the alarm module into a protective case.

In a normal home alarm installation, the alarm 'works' are normally hidden away for security (in a cupboard, for example). For this reason, the box need not look 'pretty', more functional.

We assembled the prototype into a zippy box with two mains terminal strips on the lid for connecting the various leads. A four-way block at one end connects to the sensing loops, while a six-way at the other end connects to the battery, key switch and alarm device. A separate 3.5mm socket is fitted to the case to accommodate the plug from the mains adaptor.

We have shown the alarm system powered by a plug-pack eliminator with battery stand-by in case of power failure. The battery can be an external type, such as a large 9 volt battery, to give extra life. However, there is plenty of room inside the case if you wish to place a standard 9V (or even two batteries connected in parallel). For longest life, alkaline batteries are recommended.

The sensing devices themselves can be any of a large number of types specifically designed for this purpose.



Figure 6

In the 'normally closed' loop one might find tiny magnetic reed switches (these are buried in, or screwed to, the window sill/door post, and are held closed by a small magnet on the window or door itself. If the window/door is opened, the magnet moves away and the switch opens). Alternatively, micro switches, thermal switches, metallic window tape, etc, may all be used in this loop. The important thing to remember is that all **normally closed** devices are connected in **series**.

In the normally open loop, such things as pressure mats, panic switches, trap switches, etc may be used. As distinct from the above type, **normally open** devices are connected in **parallel**.

Remember whatever alarm device you choose, it too should have battery back-up if operated from a mains adaptor. There is no point in detecting an intruder if the alarm doesn't sound! It is also a wise move to have the alarm device mounted in a very inaccessible location: the intruder has less chance of disabling it! High up under the eaves of the house is usually satisfactory, particularly if covered with a mesh guard.

Much more information on fitting alarm devices, and their uses, is given in our guide: 'How to install a burglar alarm', (Cat. B-6000). If you don't know much about alarms in general and installation in particular, then this booklet would a good investment.

# how it works

Power for this circuit is available from two sources: first is a 'plug-pack' or other power supply operating from the mains; second is a battery back-up should the mains supply fail or be tampered with by an intruder.

So long as the voltage from the adaptor equals or is greater than the battery voltage, the battery is kept isolated by D2. As a diode needs at least 0.6V potential between its anode and cathode to turn on (with the anode the more positive), it does not allow any current to flow from the battery whenever the adaptor is supplying power. This should ensure the batteries have a very long life.

When power is turned on (normally via a 'key' switch outside the building), the circuit is armed. No action occurs because the IC shorts out C3 and C4, preventing them charging, and the normally closed switches between TR1's base and emitter stop TR1 from turning on.

The circuit remains in this state until

triggered. If one of the normally closed switches is opened (a window or door switch, for example), TR1 immediately turns on, taking the collector voltage to a very low level.

If, on the other hand, one of the normally open switches is closed (an intruder stepping on a pressure mat, for example), the collector of TR1 is connected directly to the negative supply (even though TR1 itself remains off).

In either event, the sudden reduction in the voltage at the collector causes a similar voltage drop to be transmitted to the IC via C2. This immediately triggers the IC on, causing current to flow in the relay. The contacts close, allowing whatever alarm device connected to the contacts to operate.

When the IC fires, the short circuit across C3 & C4 is removed, allowing them to charge. Their charging current is limited by R3. Eventually, (a period of minutes) the voltage across the capacitors rises above the threshold

voltage of pin 6 (pins 6 and 7 are connected together) and the IC is forced off. Thus the relay drops out, and the alarm stops.

This 'time out' delay has been set at around 5 minutes to comply with noise pollution laws in some states, which do not permit an alarm to sound for more than a few minutes. The time out may be reduced by reducing R3 (and/or C3/C4), or increased by increasing R3/C3/C4.

If the door/window has been left open, the alarm will not re-trigger, thus obeying noise laws. However, if the window/door/etc is closed and subsequently re-opened, the alarm will be triggered again – just as outlined above.



# what to do next . . . continued

## Fitting to a motor vehicle

As this circuit operates quite happily off 12 volts, it is ideal for use as an automotive burglar alarm. In fact, if you fit the siren (project 16) and the flasher (project 1) you'll have quite a professional alarm!

In most cars, a courtesy light (sometimes called a dome light or interior light) is fitted, which operates when you open the car doors. This is a benefit if you want to fit an alarm, as it means that part of the wiring (the most difficult part, in fact) has already been done for you. All you have to do is link in to the wire connecting the door switches to the interior light and you have a sensing switch for an alarm system.

In 90% of cars, the wiring to the switches is the same: that shown opposite. As you can see, there may be fitted a 3 position switch which allows for the interior light to be controlled from inside the car. To work with the alarm, this switch would have to be left in the centre position: but as this is the position that most people leave the switch in anyway, this is not seen as a problem.

The wiring of the car burglar alarm can be considerably simplified from the home alarm, while keeping the same PCB. As most sensing switches used in car alarm installations (eg microswitches for bonnet/boot opening detection) can be wired either N.O. or N.C., we can assume the lot to be N.O. and leave out the N.C. detection loop. This saves R1, TR1 & C1. R2 is retained, but moved, as we will explain in a moment. A further saving can be made by leaving out the battery stand-by feature: it is not required in a motor vehicle, unless the vehicle battery is exposed and a thief can cut the wiring. In all other circumstances, the car battery is connected directly to the 'plug-pack' terminals on the PCB and D2 omitted.

The key switch must be mounted in a position where the thief cannot gain access to the rear of the switch and disable it. Be careful when choosing the mounting position.

Connecting the alarm to the car wiring should not prove too difficult. All you need do is identify the wire coming from the door switches (they unscrew normally so you can pull one out slightly to see the wire's colour coding), and tap into this wire at some convenient point. If you don't wish to cut and solder the wire, 'Scotchlok' connectors are ideal for the purpose: you just place the two wires alongside one another, place the Scotchlok over

*This simplified circuit shows all that is necessary to build an alarm for your car. The N.C. loop is removed, as is the battery stand-by supply. In other respects, it is identical in operation to the home alarm.*

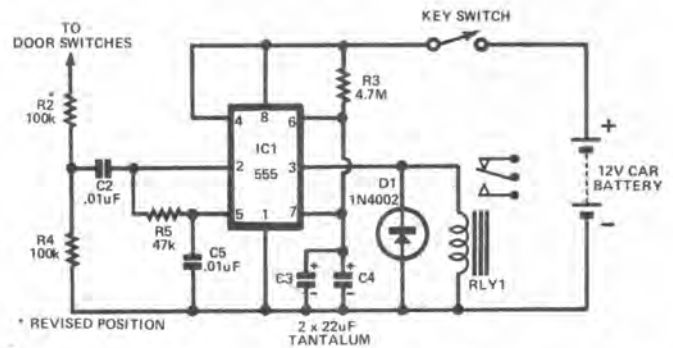

Figure 7

*Most cars are wired in this way: the dotted line shows the wire you need to add to the car's electrical system to obtain triggering for the alarm. This wire links up to the 'open' end of R2 on the car alarm PCB.*

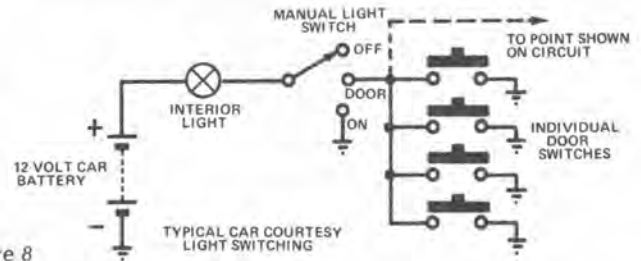
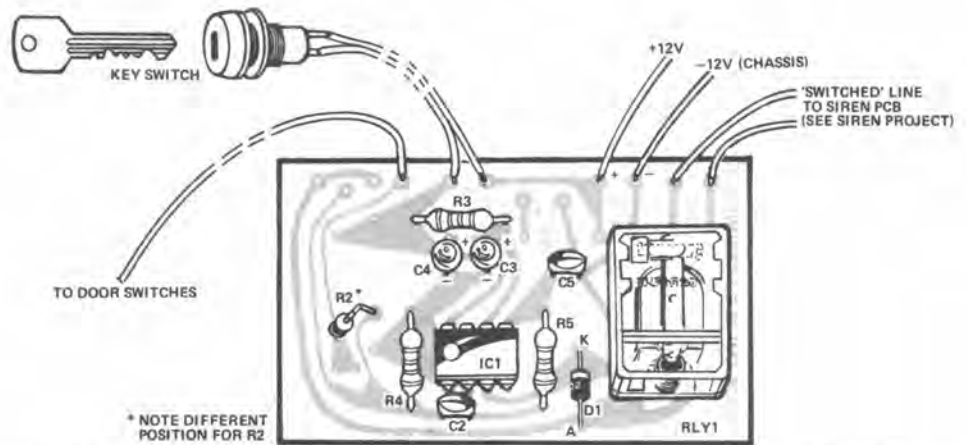

Figure 8



*You can see how much simpler the car alarm is by comparing this pcb to the complete home alarm. R2 is mounted standing 'on end' – make sure you get the right holes or the alarm won't work!*

them both, and squeeze with pliers. The connector bites through the insulation and connects the wires in an instant.

R2, the 100k resistor, does virtually the same job in the revised car alarm as it did in the home alarm. Note the different position on the pcb.

Notwithstanding anything we've said on this page, if you wish to use the un-modified PCB (the home alarm version) in your car, this is quite in order. Remember, however, that if you do not fit any normally closed sensors, the terminals for the N.C. loop should be kept shorted at all times.

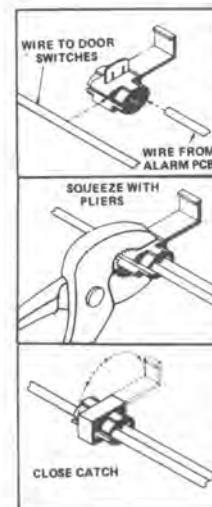

*Using 'Scotchlok' connectors: These are very handy for connecting to car wiring without soldering: just place the wires side by side in the guides, squeeze with pliers and close the catch. Result: instant connection!*

# choosing an alarm device

As shown, the alarm circuit ends in relay contacts: the choice of warning device is left to you. The relay contacts act simply as a switch to turn on your alarm device.

## In your home . . .

The easiest, simplest and probably one of the best alarms for the home is a big, loud bell – like a fire bell. These normally operate from a low voltage and thus can be switched safely by the relay. If the bell you obtain operates from a higher voltage, or if the current it draws is beyond the capacity of the relay contacts, you will need to use another relay, switched by the one on the PCB. (See 'Using Relays' elsewhere in this book).

An alternative is to build the siren in the next project (project 16) and connect it to the alarm relay. As we will mention in the siren project, an efficient horn speaker will give a good, loud blast: enough to scare even the most determined felon away! It might even be cheaper to build the siren than buy a bell these days!

## In a car . . .

Most people immediately imagine that the car horn is the best warning device in a car. In some ways, they're right: the horn is already 'in situ', all that needs to be done is connect the alarm to it.

But here are where the disadvantages come in. There are a number of methods of connecting car horns used, and it often takes an expert to fathom them out.

Admittedly, most cars these days have the horn connected to the battery positive, with the horn button completing the negative supply when pressed.

But there are many cars that are wired opposite to this. And some cars use horn relays as well: just to complicate the issue!

Another problem lies in the fact that the simple on-board relay we use in the alarm **will not** handle the very heavy current drawn by a car horn. A separate horn relay would need to be fitted to control the horn in any case.

If you think you are capable of using the car horn for an alarm, be careful. Consult the vehicle service manual for a circuit diagram before going ahead. Sounds complicated, doesn't it?

That's why we recommend fitting the system shown on this page: it has the alarm module, flasher and siren module – all in one neat package!

# a complete car alarm system.

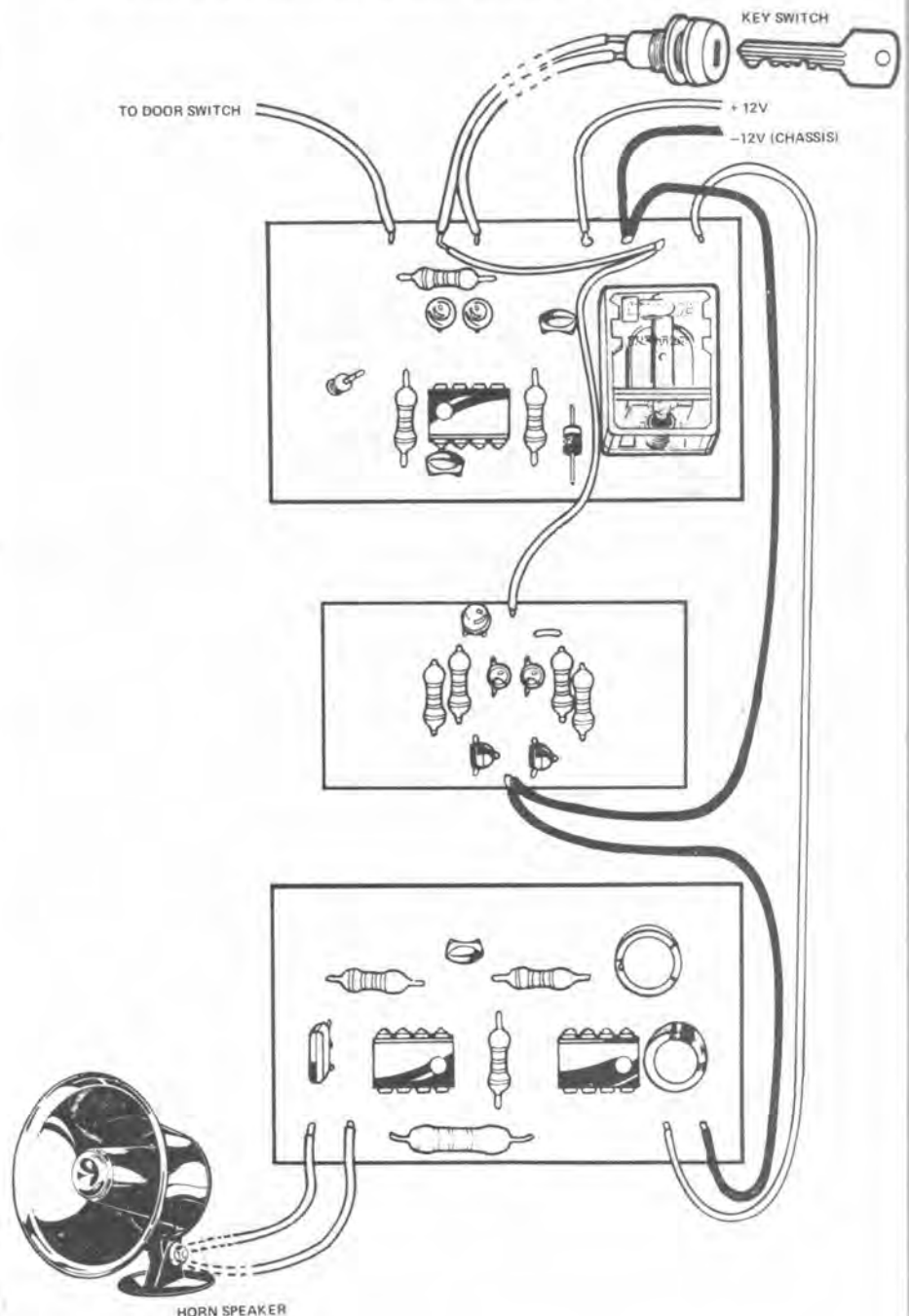

Figure 11: A complete car alarm system using three 'Fun Way' projects: the alarm module itself, the flashing LED (to act as a deterrent), and, should the worst happen, the siren, with an efficient horn speaker to give a warning.

The three printed circuit boards can all be fitted in the same Zippy box; however, the LED pcb is smaller than the other two and will need to be glued into position. It could be glued onto the front panel of the box, so the LED can poke out

through a hole in the panel.

Wiring between the three pcb's is quite simple; the alarm and flasher pcb's are both controlled by the key switch. The siren pcb is switched via the relay.

Mount the siren speaker (Dick Smith cat no C-2705 or similar) underneath the bonnet, or in some other location which is both hard to get at for the thief, but allows the sound to escape.

# project number sixteen

## Electronic Siren

Here's a project that is both fun to make and is very useful: as a warning device, it's hard to beat a siren!

This one simulates the 'hee haw' sound that modern police sirens make – but it can be made to make other sounds too.

Add a horn speaker to this and you've a first rate burglar alarm siren (it's ideal for use with the home alarm, project 15).



### you will need these components

#### Resistors:

- R1 10k ohms
- R2 10k ohms
- R3 100k ohms
- R4 4.7 ohms 1 watt

#### Capacitors:

- C1 47uF 25V electrolytic RB
- C2 .0047uF polyester (greencap)
- C3 100uF 25V electrolytic RB

#### Semiconductor Devices:

- IC1 555 timer integrated circuit
- IC2 555 timer integrated circuit
- TR1 PNP transistor BD140 or similar

#### Miscellaneous:

- 8 ohm loudspeaker

You will also require a 9 volt battery (not normally supplied with a kit) or some other 9 volt DC power supply. Note: We tested out prototype and found that it worked well on anything from 3 to 15 volts.

A suitable mounting board or printed circuit board of correct design (DSFW2 K-2636 **Electronic Siren** kit contains the correct PCB).

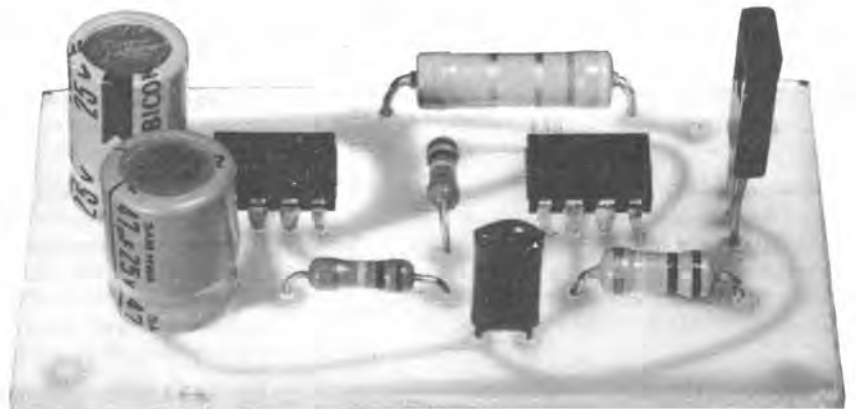

# putting it together

- (1) If you have purchased a kit (Dick Smith Cat. K-2636 or similar), check off the components against the above list to make sure they are all there and are the correct types and values.
- (2) If you have not purchased a kit you will need to obtain the components listed and either make a printed circuit board using the component position drawing as a guide, or use a perforated or tracked board.
- (3) Mount the components as shown in the component position drawing. Place and solder the resistors and capacitors first, taking extra care with C1 and C3 as they are electrolytic and therefore polarised. Check that all components are positioned neatly and properly dressed before soldering them in.
- (4) Mount TR1 in the correct place and with the correct polarity, taking particular care as it will fit easily both ways and is therefore easy to get the wrong way around. Notice that the emitter (E), collector (C) and base (B) are clearly marked on the transistor and match them up with the correct pin holes in the board. Solder the transistor in, using a heatsink clip to prevent damage from overheating.
- (5) Now the integrated circuits, IC1 and IC2. These may be the first IC's you have ever attempted to solder in but if you follow the steps you will find it straight forward and not too difficult. Insert the IC into the holes on the PCB until the little shoulders on the pins prevent it from going further: make sure it is the right way around by noting that pin 1 (the one marked with the small circle indented into the top of the IC) is connected to the negative track which is common to C1; then turn the board over and carefully solder each of the pins to the pads, making sure you don't run solder between the pads. Although it is important not to overheat the integrated circuit, it is just as important to apply sufficient heat to obtain a correctly soldered joint. (See **How to Solder**). Inspect the connections to make sure you've soldered them all without shorting out any of the pads and that's it - do IC2 in the same way noting that pin 1 also goes to the negative track that joins
- (6) Connect and solder the speaker wires to the PCB at the pads marked SPKR and then solder the other ends to the speaker.
- (7) Solder on the battery snap wires, again taking care to see that you have the correct polarity - red (positive) to the pad marked '+' and black to the negative pad, marked '-'.
- (8) Before you connect the battery check again that all of the components are in the right place, the correct polarity and soldered in properly. Clip off all excess wire and leads.
- (9) Connect the battery and your siren should make the characteristic 'hee haw' sound that police cars make. For ways to change the sound of the siren and details of how to mount it in a box and connect it for different uses read on to **What to do next**.

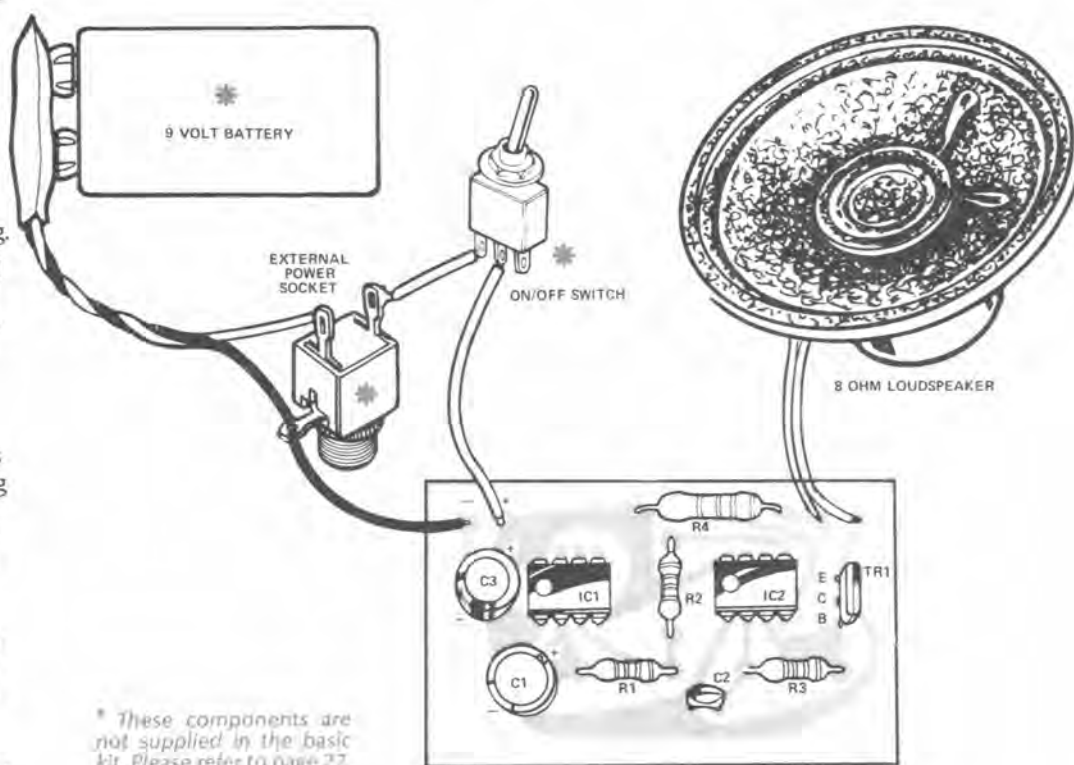

\* These components are not supplied in the basic kit. Please refer to page 27.

## what to do next

Like other projects, we have shown how to place the siren, along with a small speaker, on/off switch and extension power socket, in a Zippy box (Dick Smith Cat. H-2753 or similar). The external power socket is a good idea for this project, particularly if you have a serious security usage in mind. While it will operate for a reasonable time on the 9V battery, an external supply is a much better proposition (even if it is only a much larger battery!)

We have shown this siren with a small 8 ohm speaker – and, in fact the kit comes with one of these. This is fine for the project builder; it makes enough noise to drive anyone mad!

However, if you are using the siren in an application where a lot of noise is needed (in an alarm, for example), you would be much better off replacing the small 8 ohm speaker with a horn speaker. Horn speakers are highly efficient compared to the normal type. This siren module, when fed into a horn speaker, is really deafening!

Horn speakers are inexpensive (under \$10 for some models) and are a worthwhile investment. You can pick one up where you bought your siren.

A further modification you may care to make involves replacing the switch. If you are using the siren in conjunction with an alarm module, the contacts of the alarm relay can be used to switch the siren on. Simply remove the switch, and connect the 'normally open' contacts of the relay in their place.

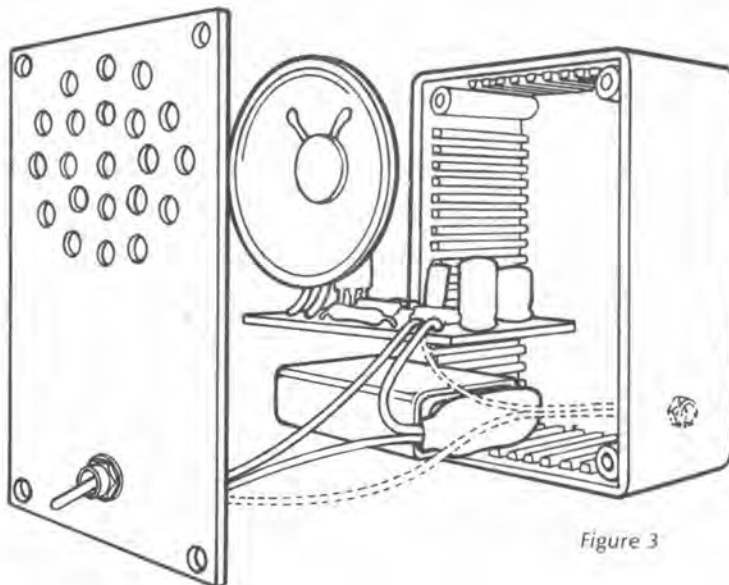

Figure 3

Check that you've chosen the right contacts before installing the alarm in a difficult location!

Obviously, there are a host of other uses not involved with security alarms. For example, if you have a phone which is difficult to hear outside the house, why not fit the sound operated switch close to the phone (even a box that it sits on!), connected to the siren module with a horn speaker outside where you can hear it. Such an arrangement doesn't make any connection to the phone or wiring (which might contravene Telecom regulations) and it is much cheaper than getting a large outside bell fitted. The siren circuit and speaker could be connected to a change-over switch which connects the siren to a burglar alarm when you're away from home.

The 'hee haw' siren sound may not be everyone's cup of tea: especially in an application like the remote 'phone bell above. It is easy to change the circuit to produce two other sounds for other applications.

First of all, removal of C1 (or including a switch so it can be switched in and out of circuit) stops the 'hee haw' sound and the siren gives a single tone.

Alternatively, try connecting an electrolytic capacitor from pin 5 of IC2 to the negative supply. Depending on the value you choose (say from 10uF to 1000uF, 16VW) the siren produces a variety of different sounds.

Or if you want to alter the speed of the siren, C1 can be increased in value (to increase the lengths of the 'hees' and 'haws') or vice versa.

## how it works

The siren is a good example of how electronic circuits can control one another.

In the siren, there are two oscillators, one of which switches the other, producing the characteristic 'hee haw' sound.

The oscillator based on IC2 is responsible for producing the sound. Its output is connected to the base of TR1, which amplifies it to drive the speaker. R4 is included to limit the current through TR1 to a safe level.

The frequency of oscillation of IC2 is basically dependent on R3 and C2 – if either of these are changed, the frequency will change also.

There is another factor which governs the frequency of oscillation. If a voltage is fed into pin 5, the internal

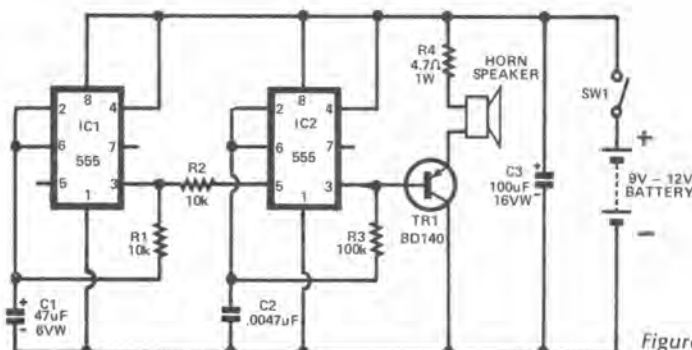

Figure 4

circuitry of the IC is forced to re-set the IC at a different time than it would have otherwise done – thus changing the frequency.

IC1 is also connected as an oscillator, but it runs much slower than IC2; around 1Hz. Each time the IC triggers, the voltage at pin 3 goes

high. As pin 3 is connected to pin 5 of IC2, this forces IC2 to change its note. Thus we get the 'hee haw' sound of the siren.

There are a couple of ideas in 'what to do next' to change the note of the oscillator, if you want to do some experimenting.

# Milestones in Electronics

## The Valve Oscillator (c. 1912)

(See 'What is a valve – page 58')

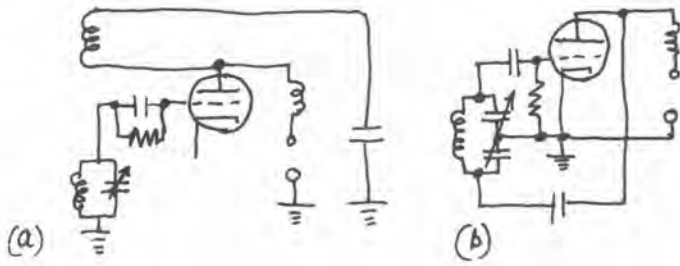

On October 25th, 1906, **Lee De Forest** applied for a patent on a three-element vacuum tube – the 'Audion'. This was the first device capable of amplifying an electric signal. Electronics was born!

It was not until 1912 or thereabouts that the Audion was used in a circuit that is universally called an 'Oscillator'. (See Edwin Howard Armstrong).

While many individuals seemed to come up with the idea at the same time, they all had one feature in common: part of the output was fed back into the input to cause the circuit to 'oscillate'. This is called positive feedback, or regeneration.

This circuit could be tuned to generate fairly fixed carrier frequencies for wireless telegraphy, and eventually replaced the less efficient spark-gap transmitters.

The two types shown are typical of designs at the time. In circuit (a) feedback occurs by magnetic coupling between the two coils, in circuit (b) there is capacitive feedback.

This is the affectionate, but very descriptive title for a circuit which is used very commonly in all digital computers today. In various similar forms, it can be any of the following: a 'monostable multivibrator', an 'astable multivibrator', a 'bistable latch', a 'frequency counter', a 'frequency divider', a 'memory', a 'square wave oscillator', etc etc.

Basically the circuit is symmetrical. When one half of the circuit (ie in this case one valve and associated circuitry) turns 'on', at the same time it forces the other half to turn 'off'.

Depending on what you want the flip-flop to do, it may 'toggle' over to the other half of the circuit of its own accord, or with the application of an input signal.

## The Flip-Flop (c. 1919)

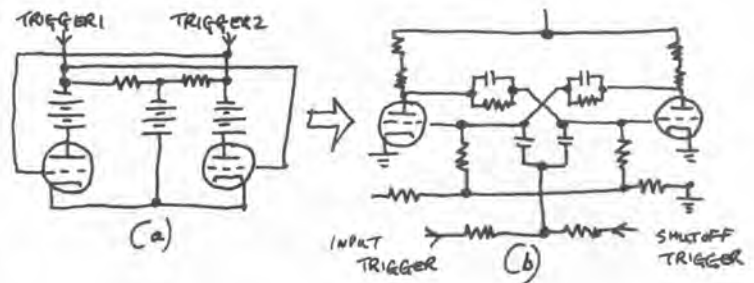

Because the strength of an incoming radio signal varied enormously, it became apparent in the early days of radio that a system that automatically accounted for this would be very handy.

The circuit basically takes part of the amplified signal in DC form and uses it to control the amplification of an earlier stage.

In other words, if the incoming signal level goes down, the DC voltage controlling the gain (or amplification) of the early stage goes down as well. However, this reduction in voltage causes the valve to have more gain, automatically providing more amplification for the weak signal.

The circuit appears in one form or another in virtually every radio and TV receiver, and countless other products.

## Automatic Gain Control (c.1926)

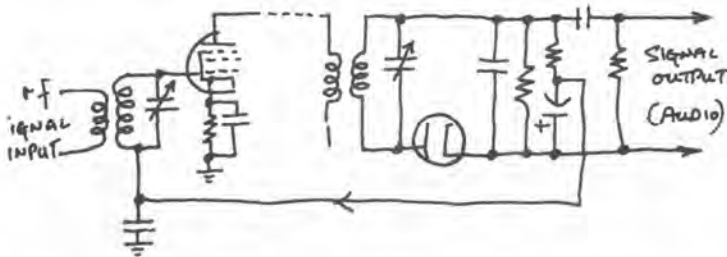

By 1927, researchers began in earnest to improve the quality of reception and reproduction. While great strides were being made at the time, several problems were proving difficult to overcome. One of these problems was **distortion**.

As the signal was being processed (particularly during amplification) distortion of the signal crept in.

One circuit which went a long way towards reducing distortion (but not eliminating it), was called **negative feedback**.

'Negative' feedback, like AGC, involves feeding back part of the output signal to the input. The difference in this case is that the feedback signal is 180° out-of-phase with the normal input signal.

This procedure tended to reduce the overall gain (or amplification) of the section but it stabilises that (lower) gain over a wide band of frequencies, as well as reducing noise and distortion.

## Negative Feedback (c. 1927)

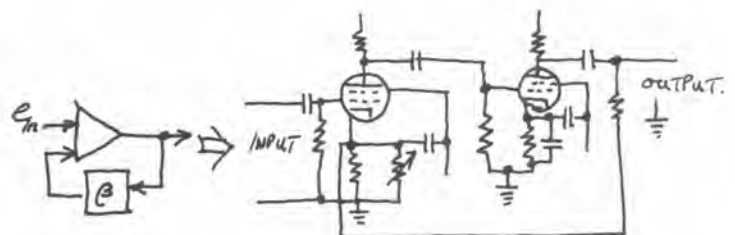

# project number seventeen

## LED Level Display



You've seen those expensive imported amplifiers with their impressive level displays dancing up and down in time with the music . . . Here's one you can build yourself that does exactly the same thing – and you can add it onto any amplifier (even a transistor radio!). Build two of these and you've a professional quality display you'll be proud to add onto your home stereo system. It's even possible to have the display calibrated to show various power levels. It's a beauty!

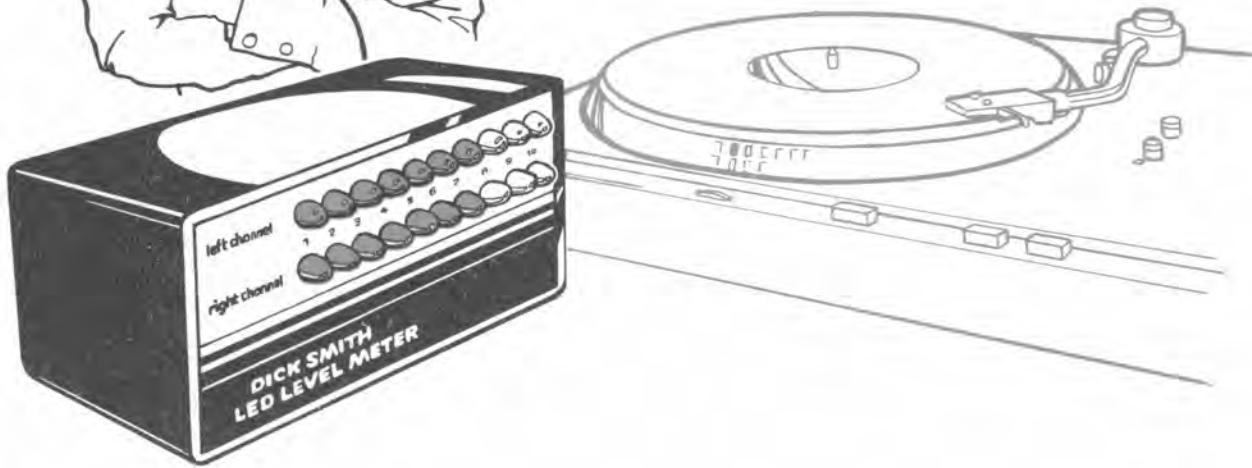

you will need  
these components

### Resistors:

R1	470 ohms
R2	4.7k ohms
R3 to R12	330 ohms
R13	10k ohms
R14	10k ohms
R15	8.2k ohms
R16	8.2k ohms
R17	6.8k ohms
R18	5.6k ohms
R19	4.7k ohms
R20	3.9k ohms
R21	3.3k ohms
R22	2.7k ohms
RV1	100k ohms trim-pot

### Capacitors:

C1	2.2uF 25 volt electrolytic
C2	2.2uF 25 volt electrolytic

### Semiconductors:

D1 – D10	1N914 silicon diodes
TR1	DS558 PNP transistor or similar
TR2 – TR11	DS548 NPN transistors
LEDs 1 – 10	Red Light Emitting Diodes

### Miscellaneous:

Battery snap, solder, hook-up wire  
2 sockets (if required: see text)  
You will also require a 9 volt transistor battery (not normally supplied with a kit) or some other 9 volt DC power supply.

A suitable mounting board or printed circuit board of correct design (DSFW2 K-2637 LED Level Display kit contains the correct pcb).

For low power operation, two additional resistors are required: one 4.7M and one 270k.

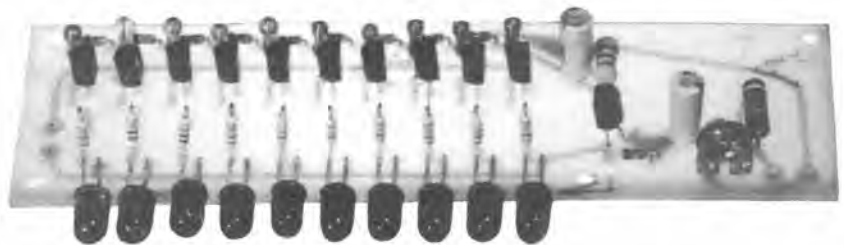
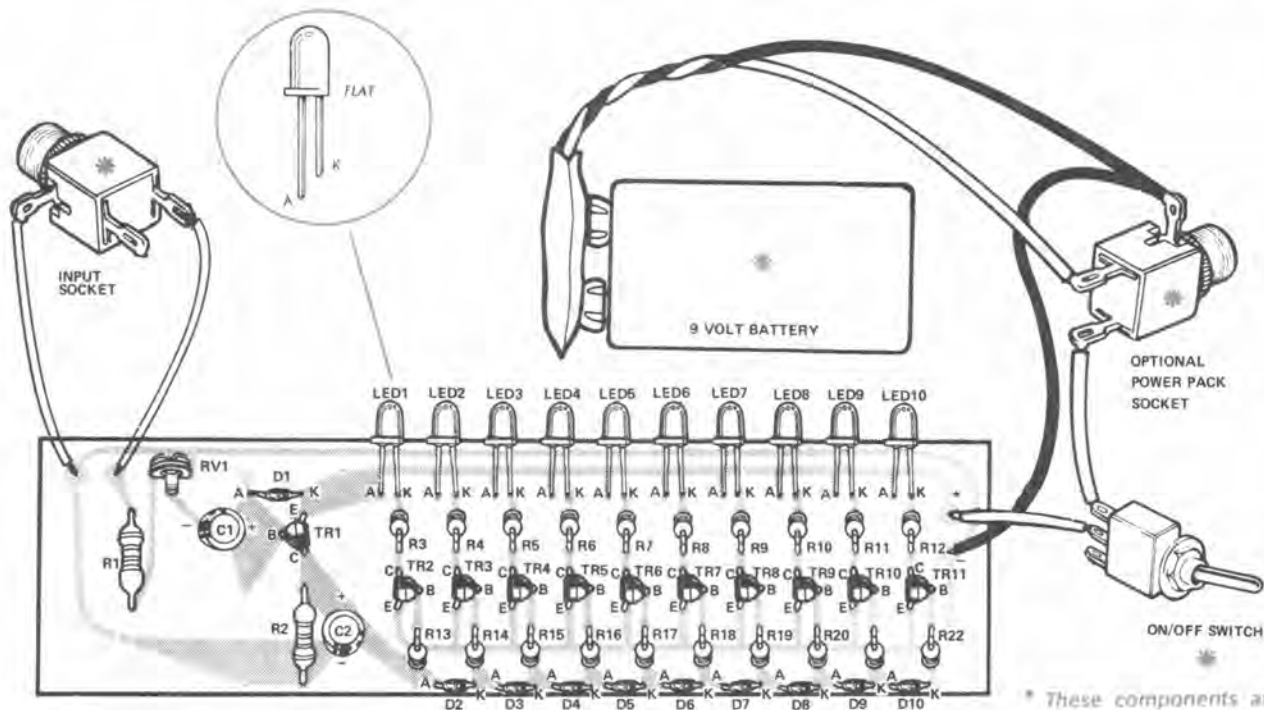

Figure 1

# putting it together

- (1) If you have purchased a kit (Dick Smith Cat. K-2637 or similar), check off the components against the above list to make sure they are all there and are the correct types and values.
- (2) If you have not purchased a kit you will need to obtain the components listed and either make a printed circuit board using the component position drawing as a guide, or use a perforated or tracked board.
- (3) Mount the components as shown in the component position drawing. Position and solder the resistors and capacitors first, taking special care to see that C1 and C2 are the correct way around as they are polarised. To save space on the PCB, you will notice, the resistors are mounted vertically with the upper lead bent back down to be soldered into the other pad. In this case the PCB layout is very close to the circuit diagram. Check that all components are positioned neatly and properly 'dressed' before soldering them in.
- (4) Solder in RV1 after making sure that you have it the right way around.
- (5) Now the diodes can all be placed and soldered. Remember the banded ends are the cathode (K) end. On this PCB they will all be towards the same end of the board as shown in the component position drawing.
- (6) The LED's can now be placed and soldered. Notice they are placed so that after they are soldered in they may be bent up so that the bottom of the plastic light part is level with the edge of the board. Be careful to place the LED's with the correct polarity – that is, with the cathode to the ends of the resistors.
- (7) Solder in TR1, making sure that you have the correct PNP transistor (DS558 or similar), then TR2 to TR11 may be soldered in taking care to ensure that they are all placed the right way around. Use a heatsink clamp to prevent damage to the transistors from overheating.
- (8) Solder on the battery snap wires, again taking care to see that you have the correct polarity – red (positive) to the pad marked '+' and black to the negative pad, marked '-'.
- (9) Before you connect the battery check again that all of the components are in the right place, the correct polarity and soldered in properly. Remove any excess wire and leads.
- (10) To test the circuit connect the battery and then connect your amplifier speaker output to the pads marked 'IN' on the PCB. The LED's should light in order with more staying on as the volume increases. If all come on and stay on it indicates that the volume is too high or, if you can't get them to go off by decreasing the volume, there may be something wrong with your project. See **What to do next** for details on mounting one or two **LED Level Displays** in a suitable box.

*Looks complicated – but it is really very simple! Take care with the orientation of the LEDs – the anode (the longest lead) is always on the left side looking at the pcb as shown below. There are four holes not used in the diagram below: these are for two additional resistors required for low power operation (see over page).*



\* These components are not supplied in the basic kit. Please refer to page 27.



# how it works

The input to the LED Level Display is connected to the speaker terminals of your amplifier (obviously, you will need two displays if you wish to show both stereo channels). The input is connected in parallel with your speakers.

It does not effect the amplifier or the speakers, however, as the Display input has a very high impedance compared to your speakers (over 100,000 ohms compared to 8 ohms or so for your speakers!)

When audio signals are fed into the input, the voltage across RV1 follows that of the signal. Depending on the setting of RV1 (which is basically a level control), a certain proportion of

this voltage is transmitted to the base of TR1 via C1.

Because TR1 is a PNP transistor, the positive-going voltages of the audio signal will be ignored. But the negative-going voltages will cause TR1 to conduct: the amount of conduction dependent on the voltage (which, as we said, is dependent on the audio level).

When TR1 conducts, the voltage at its collector (which was virtually zero) rises. The more TR1 conducts, the higher the voltage goes. When the voltage exceeds 0.6 volts, TR2 conducts, lighting LED 1. As the voltage rises another 0.6V (the turn-on voltage of the silicon diode), TR3 turns

on. Another 0.6 volts and TR4 turns on. Another 0.6 volts, TR5 – etc, etc. The last diode lights with a voltage of about 6 volts at TR1's collector: corresponding to a very loud signal!

The effect is that of a bar of light, increasing and decreasing in length continuously as the volume of the audio input changes.

If the display is required to be used with a low signal level (such as a transistor radio, etc) a voltage divider can be connected across the supply, with the junction connected to TR1's base. This assists TR1 in conduction, resulting in a better display from low signal levels.

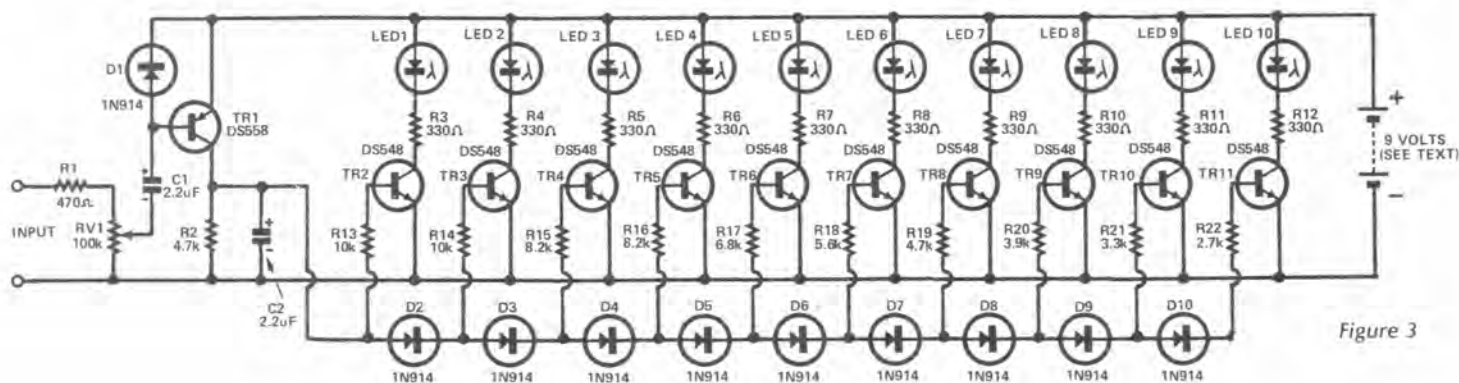

Figure 3

# what to do next

Our drawing of the LED Level Display (figure 4) actually shows two pcb's fitted in one Zippy box. Obviously, you can use one board only if you wish for a mono display, but we're sure the majority of constructors will want a second board to display both stereo channels. The PCB has been designed to allow two boards to fit in with ease.

You may also have noticed that we have shown a 9 volt battery, plus a socket for a plug-pack adaptor. While the circuit will certainly operate from a battery, with a number of LEDs going at one time, drain from a small 9 volt battery would be excessive. So a plug-pack adaptor for this project is almost mandatory – unless you have a relative in a battery factory, and don't mind changing them very often!

Fitting two display pcb's is just the same as fitting one: unlike the LED Dice, no components can be shared between boards in the double LED Display. So all you do is install two boards, treating them as individuals. The only common connection points

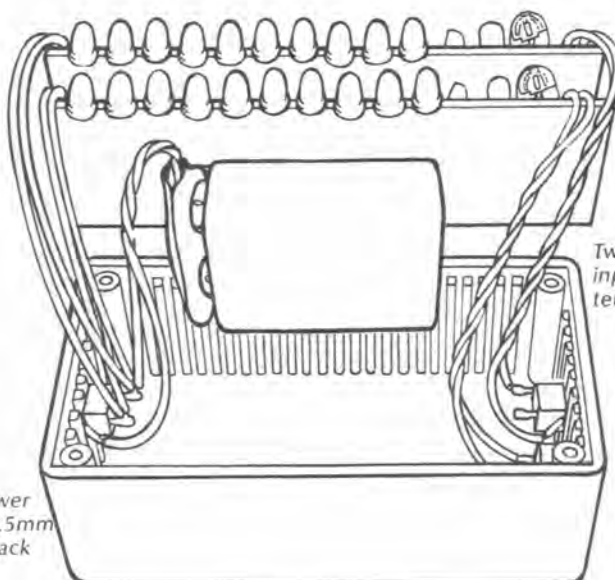
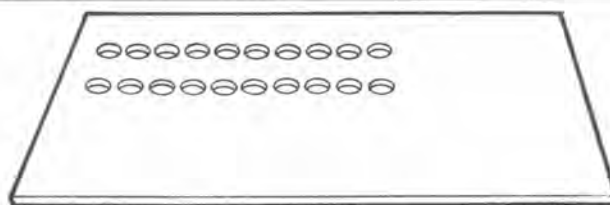

Twin sockets for audio input (from speaker terminals of amplifier).

Single external power socket (standard 3.5mm type to suit plug-pack adaptor).

Figure 4

## what to do next . . .continued

are the socket for the plug-pack: both boards are connected in parallel to the socket.

To give the project a neat appearance and for convenience & protection, we suggest you fit sockets for the input(s), as well as power. We used ordinary 3.5mm types, but you may wish to use another type of socket to avoid confusion with the socket for the plug-pack adaptor. Virtually any type of 2 pin plug and socket would be suitable, as long as you can fit it (or them) in the box along with the two pcb's and power socket.

If you wish to save the cost of the power switch (and the trouble of putting it in), it can be left out of this project. This particularly applies if you heed our advice and use a plug-pack adaptor. The minimal drain of the circuit when it is not actually displaying anything would not even turn your electricity meter!

The attractive label supplied in the back of this book will give your finished project a professional look that your family and friends will admire!

### Use on low power outputs:

As we mentioned in 'how it works', a refinement to the circuit should be made if you wish to use the display with low audio output devices. The reason for this is that such levels may not have sufficient magnitude to light up the full display.

A pair of resistors is all that is required – these are connected as shown in the accompanying drawing. They reduce the 'threshold' voltage of TR1 (that is, the voltage between zero and that required to start TR1 conducting).

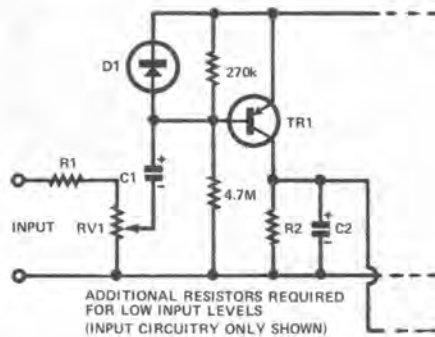

Figure 5: These two illustrations show the two extra resistors required for low power operation (for example, from a transistor radio). These resistors occupy the unused holes on the PCB: they have been included specifically for this purpose. Obviously, only a small section of both the circuit and the printed circuit board are shown, as the rest of the circuit and the PCB are identical to the original 'high power' version.

### Use in a car

This circuit is quite happy working from a 12 volt supply: so there is no problem about putting this circuit in a car, and operating it from the car stereo. One word of warning, however: a dancing display can be very distracting for a driver – keep it out of the driver's vision or fit a switch so it can at least be turned off!

### Going multi-colour!

As specified in the parts list, the kit comes with all red LEDs. However, many commercial amplifiers have level meters which feature a 3 colour display: green for low to normal levels, yellow for loud, and red for extra loud (some even have the display so calibrated that the last red LED means

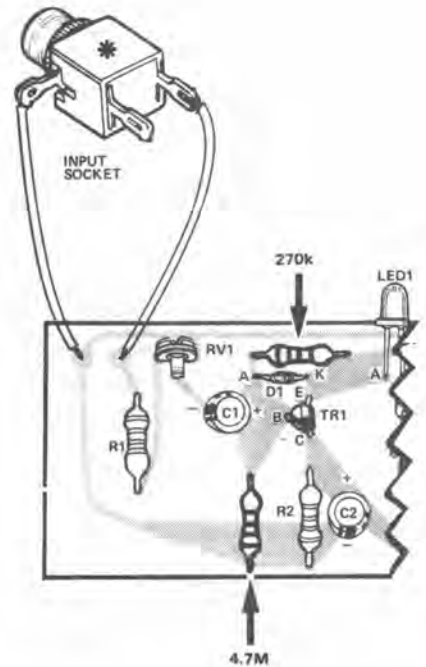

that the amplifier is being grossly overdriven and could be damaged if this level is maintained).

Wouldn't it be nice if our LED Level Display could have a multi-colour display?

It can! All you need to do is substitute some of the red LEDs with green and yellow LEDs. Normally, you would have green for about the first five LEDs, yellow for the next three and red for the last two. However, the arrangement of the colours is up to you. One thing's for sure: it makes it much more impressive!

Yellow and green LEDs should be available at the store where you bought your LED Level Display kit.

## for advanced constructors: calibrating your display

As described, the LED Level Meter flashes LEDs on a scale of one to ten. These indicate relative loudness, but do not give any idea of the actual power the amplifier is developing.

Admittedly, not many constructors will want to go to this trouble, but some may prefer their LED Display to actually measure the power output in watts. To do this, each stage of the display must be 'calibrated' to a specific power.

A word of warning: this is not for the beginner – if you want to calibrate your display and don't know too much about it, you'll need the help of someone who is more conversant with electronics, and has access to proper

test equipment – such as an audio oscillator, an oscilloscope and an accurate AC voltmeter.

First you will need to know what power levels you want each LED to represent. For example, if you have a 50 watt amplifier, you might choose 0.2W, 0.5W, 1W, 2W, 5W, 10W, 20W, 30W, 50W and overloaded.

You then connect the oscillator, CRO and voltmeter to your amplifier, and, starting at your chosen minimum, pad the diode string with extra diodes so each LED lights at the level required.

(Padding in this case, involves connecting additional diodes in series with those shown to alter the voltage required to turn individual stages on.

If you find that another silicon diode is too much of a jump (0.6V), remember that a germanium diode has a 0.2V forward voltage drop).

The second last LED in the string can be calibrated to read your amplifier's maximum rated output (or the maximum output before clipping). The last LED can then show gross overload – in other words, when the CRO shows your amplifier is badly clipping and/or distorting the waveform.

If all this sounds like gobbledygook to you, don't worry! As we said, few people will want to go to this trouble. But it's nice to know this little device can be made into quite a professional piece of test gear if you so wish!

# project number eighteen

## Home Intercom

One of the most useful projects the electronics hobbyist can make is an intercom. Think of the applications you could put one to: an intercom in the back shed saves a lot of shouting when it's time for dinner . . . an intercom near the baby's cot not only lets you listen in, but gives reassurance during the night without leaving your bed . . . an intercom at the front door allows security without danger . . . the list is endless.

Using a similar circuit to our basic amplifier, this intercom is easy to build, and operates just like those you'd pay a lot more for. It's a superb gift idea, too!

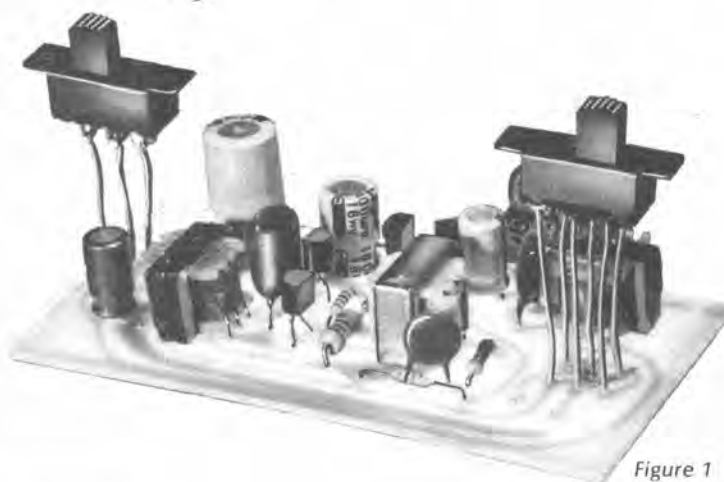

Figure 1

## you will need these components

### Resistors:

- R1 470 ohms
- R2 68k ohms
- R3 1k ohms
- R4 10k ohms
- R5 150 ohms
- R6 2.2k ohms
- R7 22 ohms
- R8 47 ohms
- RV1 1M ohm trimming potentiometer

### Capacitors

- C1 .047uF polyester or ceramic
- C2 10uF 10 volt electrolytic
- C3 100uF 10 volt electrolytic
- C4 .01uF polyester or ceramic
- C5 0.1uF polyester or ceramic
- C6 4.7uF 10 volt electrolytic
- C7 470uF 16 volt electrolytic
- C8 47uF 10 volt electrolytic

### Semiconductor devices

- TR1 DS548 or similar NPN transistor
- TR2 DS548 or similar NPN transistor
- TR3 DS548 or similar NPN transistor
- TR4 DS548 or similar NPN transistor
- D1 1N914 (or 1N4001) diode
- D2 1N4001 or similar diode

### Miscellaneous:

- T1 3k ohm to 3k ohm CT audio matching transformer
- T2 1k CT to 8 ohm audio output transformer
- T3 8 ohm to 1k audio transformer
- SP1 8 ohm speaker
- SP2 8 ohm speaker
- SW1 SPST slider switch or other SPST switch
- SW2 DPDT slider switch or other DPDT switch (see text)

- PB1 Momentary Action single pole push button switch
- Battery Snap, battery, solder and hook-up wire

You will also require a suitable mounting board: we strongly recommend that only the correct PCB be used for this project. (DSFW2 K-2638 Intercom Kit contains this PCB).

# putting it together

- (1) If you have purchased a kit (Dick Smith Cat. K-2638 or similar), check off the components against the above list to make sure they are all there and are the correct types and values.
- (2) If you have not purchased a kit you will need to obtain the components listed and either make a printed circuit using the component drawing as a guide, or use a perforated or tracked board and the component drawing as a guide.

Note: The notes below refer to the **MASTER** intercom unit.

- (3) Mount the components as shown in the component position drawing – resistors and capacitors first, taking extra care with the electrolytic capacitors as they are polarised. Check that all components are positioned neatly and properly dressed before carefully soldering them in.
- (4) Place and solder RV1, the trimming potentiometer, ensuring that you have it the right way around.
- (5) The audio transformers may be soldered in next, but be very careful that you are putting the right transformer in the right way

around, and in the right place on the PCB. First identify the transformers: we use two 8 ohm to 1k transformers (which should look the same), and one 3k to 3k coupling transformer. The 3k/3k should be easiest to identify: it is slightly larger in size. Once identified, place it in position and solder the wires onto their respective pads.

Now identify the 1k side and 8 ohm side of the other two transformers. The 1k side has three leads, the 8 ohm side two. You cannot put these transformers in the wrong way around if all leads go into the PCB: there are two pads on the 8 ohm side and three pads on the 1k side.

- (6) Solder in D1 and D2, making sure that you have them the correct polarity – the banded end is the cathode.
- (7) Now the transistors can be positioned and soldered in. Take care they are the correct polarity as well as the correct transistor. Don't forget to use a heatsink clamp to prevent damage from overheating.

- (8) Carefully solder on the speaker leads and connect and solder them to SW 2, as shown in the detailed connection drawing, and then to the PCB.
- (9) Connect and solder SW 1 to the pads on the PCB marked SW 1.
- (10) Solder the battery snap leads to the pads on the PCB marked '+' and '-'. Check the polarity carefully to ensure that the red lead (positive) goes to the pad marked '+' and the black lead (negative) goes to the pad marked '-'.
- (11) Assuming you are using a socket for connection between the master and slave (as shown), solder the socket leads to the pcb and the socket. If you are not using a socket, the twin lead that runs to the slave should be soldered directly to the pcb in the same positions as the wires to the socket: the wire on the left connects directly to the slave speaker, while the wire on the right connects to the push button & capacitor.
- (12) The last major items to be connected are the switches. Depending on the way you plan to mount your PCB in its box, these switches can be connected

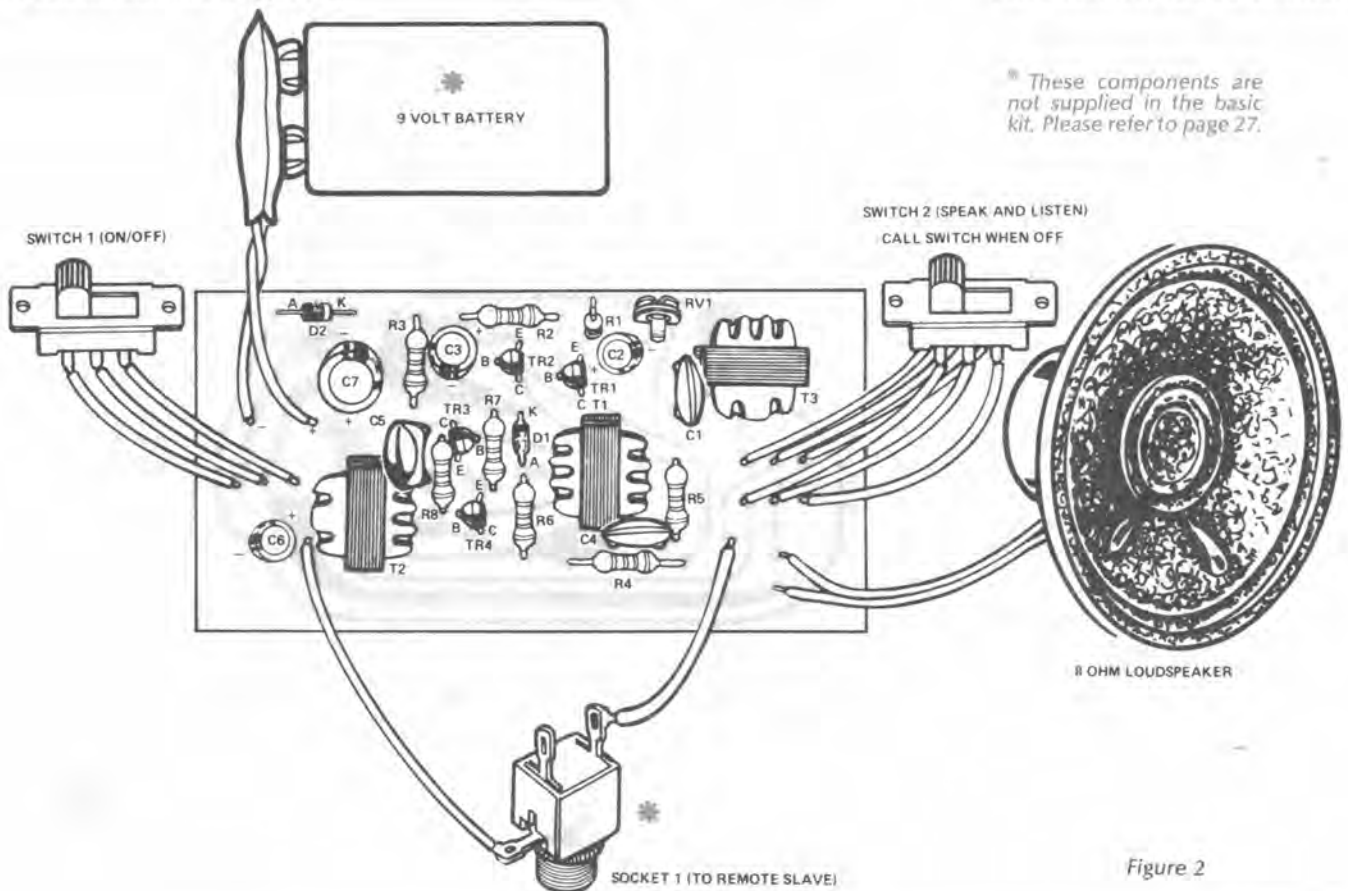

\* These components are not supplied in the basic kit. Please refer to page 27.

Figure 2

## putting it together

### ... continued

via short lengths of solid wire (eg resistor or capacitor tails); or by hook-up wire (see 'what to do next'). In either case, the holes on the PCB are in exactly the same pattern as the terminals on the switches: run your wires directly from the holes to their respective terminals. This should mean there is no chance of error in the switch wiring.

#### Wiring the 'slave' unit

- (1) Referring to figure 4, which shows the slave unit, solder the electrolytic capacitor, C8, across the push button switch, PB1. At this stage, it doesn't matter which way around you solder the capacitor.
- (2) Solder a short length of hook-up wire (10cm) from the positive side of the capacitor to the speaker.
- (3) You must decide now whether or not you are going to fit a socket to the slave to allow for easy disconnection. If you do, connect the socket as shown below.
- (4) If you are not fitting a socket to the slave, you will need to connect a length of twin wire ('figure 8' speaker wire or two lengths of hook-up wire twisted together) which will run from where you are mounting the slave, all the way to the master. Normally figure 8 speaker wire is colour coded, or has a small ridge moulded into the plastic insulation of one of the wires. Solder the darker wire, (or the one with the ridge) to the speaker terminal, and the other wire to the negative side of the capacitor.
- (5) Connect a 3.5mm plug to the other end of the figure 8 lead as shown. (If you fitted a socket to the 'slave' unit, another 3.5mm plug should be fitted to the other end of the lead, in the same way).

#### Connecting it together

- (1) Go over the printed circuit board carefully, checking that all components are correctly positioned, oriented and soldered. Check also the slave unit, and then connect the battery.
- (2) Go on try it! You've just made yourself an intercom.

## what to do next

You will find it far more convenient to use the intercom if both master and slave are housed in separate Zippy boxes, as shown below.

You will have to drill holes for the speaker baffles and slide switches: use the templates provided in the back of this book.

While we have shown and used slide switches because of their availability and economy, you might find it more convenient to replace SW1 with a standard miniature toggle switch, and SW2 with a press-button double pole momentary action switch (Dick Smith Cat. S-1220 or similar) which gives the advantage of simple press-to-talk operation.

If the intercom is to be installed in a home, you will probably want the option of mains power. This is easy to arrange: just include a socket for a plug-pack adaptor between the battery and the PCB, as shown in many other projects.

Again, for convenience, we have shown sockets for both the master and slave inter-connection. If you wish, these sockets could be

eliminated, and wires run direct from the PCB to the slave. Whichever way you wire them together, note the polarity of the electrolytic capacitor in the slave unit: electrolytics do not like being reverse connected for any appreciable period!

#### Setting the intercom up

Assuming your intercom works correctly, all you have to do is place the intercom in the location you wish to use it, and adjust VR1 for maximum level without significant distortion. Once you've done this, the intercom should be assembled in its box, and the lid screwed on.

#### Assembly in the box

If you connect the two switches via lengths of tinned copper wire (as explained above), the intercom PCB does not need any mounting of its own. When the switches are screwed to the front panel, the PCB will be held rigid enough by the switch wiring.

If you use hook-up wire to connect the switches, the PCB will have to be fastened in the Zippy box by screws, glue, etc, to make sure it doesn't

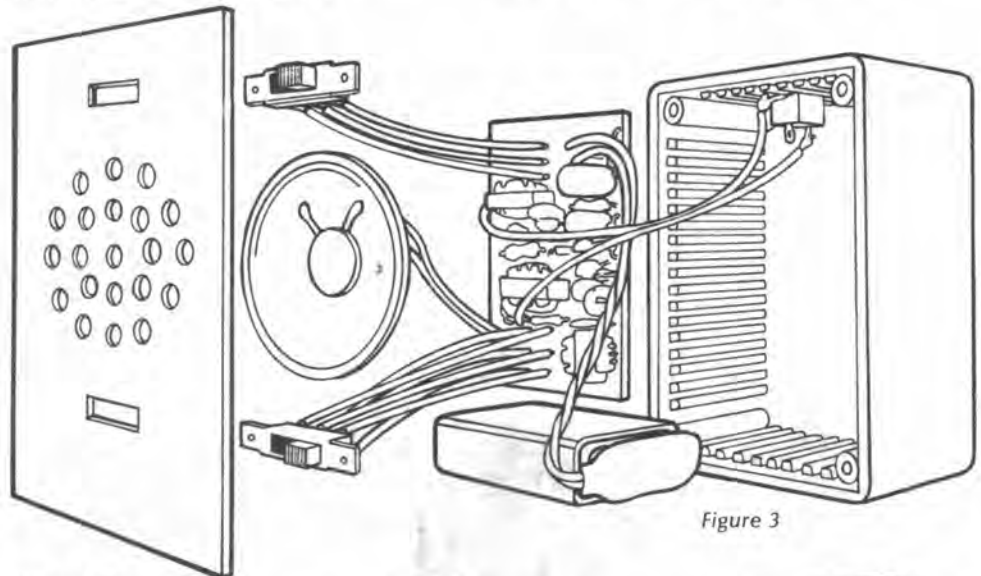

Figure 3

(Above) The 'master' PCB mounted in a Zippy box, with the control switches and battery. The switches may be mounted by short lengths of tinned copper wire, holding the board rigid, or by short lengths of hook-up wire.

(Right) The 'slave' station connections. You may care to ignore the socket in the slave station if the installation is to be permanent.

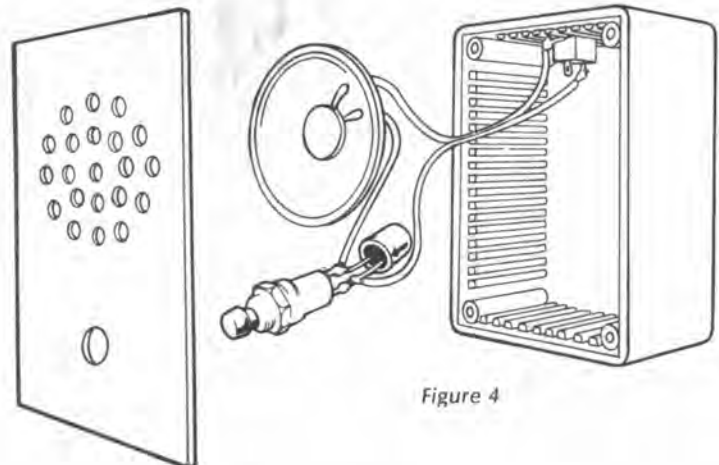

Figure 4

# what to do next . . . continued

move around and short something out inside the box.

## Using your intercom

Once you've worked out the switch combinations, you'll find a number of different ways to use your intercom. Obviously, it can be used in the normal way, where the master calls the slave after turning the unit on first; or the slave calls the master by pressing the 'call' button.

But it goes further than that: the intercom is ideal for use as a

monitoring device (in a nursery, for example). If the master intercom is turned on and left on, all sound received by the 'slave' will be heard at the master. The master can talk back to the slave by moving his switch to the 'speak' position. This feature is also of use when used as an entrance monitor; although you may find it more convenient to leave the master 'off' so any visitor is forced to press the 'call' button. (In this mode, the 'call' button can double as a door bell!)

## Using horn speakers

The speakers mounted in the Zippy boxes can be replaced by horn speakers if you want to use the intercom in a noisy environment. Horn speakers are much more efficient than ordinary speakers and should make messages more easily understood. Simply connect them where the ordinary speakers would have been.

# how it works

This circuit is quite complex in operation, especially for a beginner. However, it is much easier to understand if you break it down into its various sections.

The intercom consists of three sections: the calling circuitry (which includes the switching), the amplifier section and the power supply. The amplifier is virtually identical to the 'Simple Amplifier' (project ten), with the only difference being the inclusion of an input transformer to allow the use of a low impedance speaker as a microphone.

(For an explanation of the amplifier circuit, see project ten).

The calling circuitry and power supply depend on one another for correct operation, so we'll look at these together.

With the power switch (SW1) in the 'off' position, the circuit to the negative supply is incomplete. So all that happens is that C6, C7 and C8 charge to the supply voltage via the amplifier circuitry.

When the 'call' button (PB1) is pressed, however, a complete circuit is formed, which is in effect in parallel

with SW1. This circuit includes the slave speaker and T3, the input transformer.

So the amplifier is able to draw current, when PB1 is pressed, but all the current is forced to pass through T3's primary.

By transformer action, the minutest variation in current through the primary is transferred to the secondary. This is then amplified, which not only causes a sound from the speaker, it causes a variation in the current through T3's primary. This is transferred to the secondary and amplified, which causes a sound from the speaker, which causes a variation in the current, etc, etc, etc.

Within a very short time (a few thousandths of a second) the amplifier has become an oscillator, resulting in a 'squark' from the master speaker.

This action is called 'positive feedback' – where the output of an amplifier is fed back into the input and amplified again, over and over.

Note that this positive feedback (and oscillation) occurs only while the call button is pressed.

Assuming that the call has been heard by the 'master' station, (and the call button has been released), the 'master' operator turns on SW1 – the power switch. This supplies current to the amplifier in the normal way (not through T3's primary), and the amplifier can operate normally.

If the slave wants to talk to the master station (which, we presume, is why he pressed the call button in the first place!), the master station sets the switch to 'listen'. This connects the slave's speaker to the input transformer, turning it into a microphone. The master's speaker is connected to the output of the amplifier, so he can hear what the slave has to say.

To talk back the other direction, the master switch is set to 'talk'. This reverses the speakers: the master's speaker becomes the microphone, and the slave's speaker can hear what the master says.

What if the master wants to talk to the slave in the first place? He has no call button: all he does is turn SW1 to on, and SW2 (the listen/talk switch) to talk, and talks! If anyone is within earshot of the slave, they'll hear it.

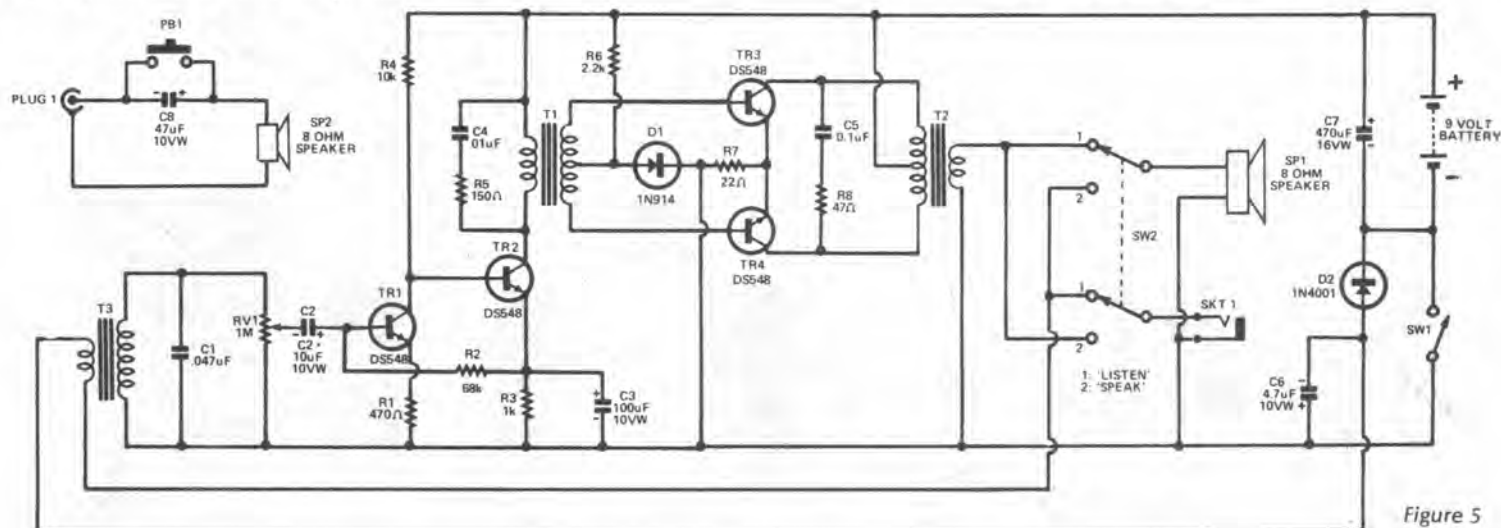

Figure 5

# project number nineteen

## LED Counter Module



Digital watches. Digital computers. Digital meters. Digital car radios. Everything, it seems, is going digital.

Digital electronics is a whole new ball game. An understanding of digital electronics now will help you keep up with the remarkable changes in technology that we are going through. If you don't understand digital technology, in a few years you might find yourself spiked, mutilated or folded just like a discarded computer card!

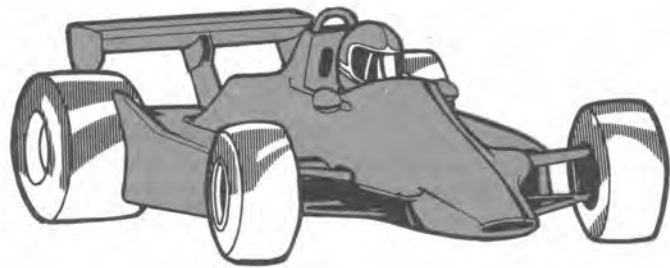

When thinking of a digital project for this book, we tried to think of something that would be both useful and educational. We thought about digital clocks, but these days it hardly seems worthwhile to build a clock when everything is available in one 'chip' (or integrated circuit)!

Then we thought about a simple digital counter. One that could count from 0 to 9, and, if necessary, could be added to to give as many figures of display as required. It seemed like an ideal project for the beginner, too: so here it is – the Fun Way Digital Counter.

To keep the cost of the basic counter kit to a minimum, we are showing the counter in two halves. The first is the counter itself, complete with push buttons to count with and re-set the counter to zero.

The only trouble with this idea is that the counter is actually too good: when you press the push button, the contacts do

not close in a single action. They close, bounce open, close again, bounce open, maybe four, five times – or more. In 99.9% of applications, this 'contact bounce' (which happens in all switches) doesn't matter. In a digital counter, it does: each time the contacts bounce, the counter reads this as another action: so instead of getting the counter to advance by 1 each time you press the button, it might advance by 2, 3, 4 – even 10 counts at a time!

So we have designed the PCB so that extra circuitry – not included in the basic kit – can be added to eliminate this contact bounce, where it is seen as a problem.

Anyway, more of this in 'What to do next' – after we've put the counter together.

Figure 1

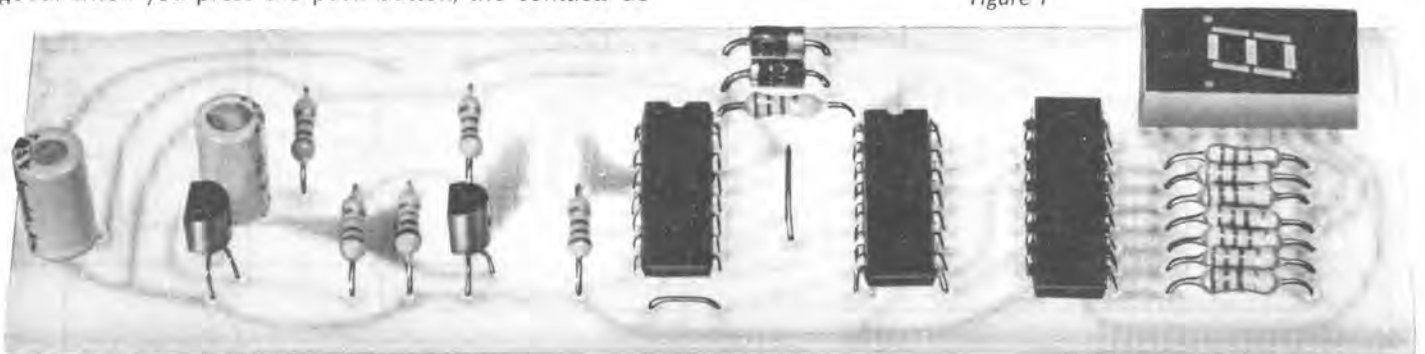

# putting it together

- (1) If you have purchased a kit (Dick Smith Cat. K-2639 or similar), check off the components against the above list to make sure they are all there and are the correct types and values.
- (2) If you have not purchased a kit you will need to obtain the components listed and either make a printed circuit board using the component position drawing as a guide, or use a perforated or tracked board.
- (3) Mount all the components except the integrated circuits, as shown in the component drawing. Solder these in, and remove their pigtails.
- (4) With some of the pigtails you've just cut from the resistors, make up and insert the two links on the PCB. Solder these in.
- (5) Now position IC1, IC2 and IC3. These are not CMOS IC's, so you don't have to be quite so careful with them as with CMOS. But they don't like too much heat, either! Ensure they are correctly oriented: all go in the same way; pin number 1 (closest to the dot on the IC body) towards the bottom right side, looking at the PCB as shown in the drawing.
- (6) Now to the LED display, IC4 (actually, a LED display isn't really an IC, but it's convenient to call it IC4 as it is in a similar

package to the IC's). The readout can be inserted flat onto the PCB, as shown in the drawing, or it can be mounted at 90° to the PCB, with some of its pins soldered to the back of the board (see figure 3). This method is used if you wish to make a number of boards for a multi-digit readout, and stack them side-by-side. (This is further explained in 'What to do next'. It might be a good idea to read this section before deciding which way around you want to mount your display, as once soldered, they can be fairly difficult to remove). Once you've decided which way around you want to mount your LED readout, solder it in this position. If it is flat on the board, the operation is straightforward; it fits only one way. If you are mounting the LED edge-on, the correct pins (the side with 5 pins only) are placed over the edge of the PCB, and the pins are soldered to the tracks that run right up to the edge. Make sure your LED is at 90° to the PCB, then use pigtails from resistors to connect the other 6 pins down to the PCB (see drawing again). This can be quite tricky, so take your time.

- (7) Solder on the wires for the battery (don't use a battery snap; they don't fit a 509 battery!).

# you will need these components

### Resistors:

- R1 220 ohms
- R2 220 ohms
- R3 1k ohms
- R4 to R10 150 ohms

### Capacitors:

- C1 33uF, 10 volts electrolytic

### Semiconductor Devices:

- IC1 7490 decade counter
- IC2 7475 quad latch
- IC3 7447 decoder/driver
- IC4 LT302 7 segment display
- D1 1N4001 diode
- D2 1N4001 diode

### Miscellaneous:

- PB1 Momentary action single pole push button switch
- PB2 As above
- 6 volt lantern battery, Eveready type 509 or similar (not normally supplied with the kit).
- Solder, hookup wire, etc.

You will also need a suitable mounting board or printed circuit board of correct design (DSFW2 K-2639 LED COUNTER KIT contains the correct PCB).

Follow this diagram carefully and you shouldn't have any problems putting the basic counter together. The blank area on the right end of the PCB is used for extra circuitry, described overleaf.

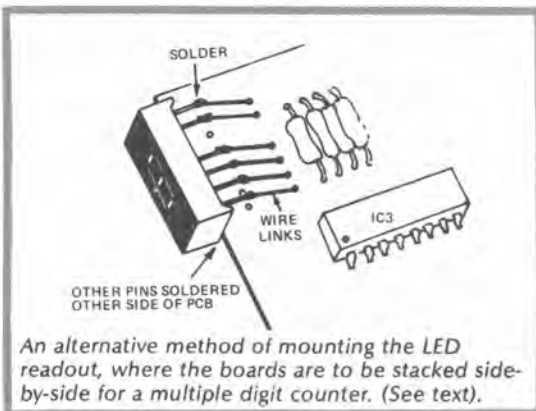
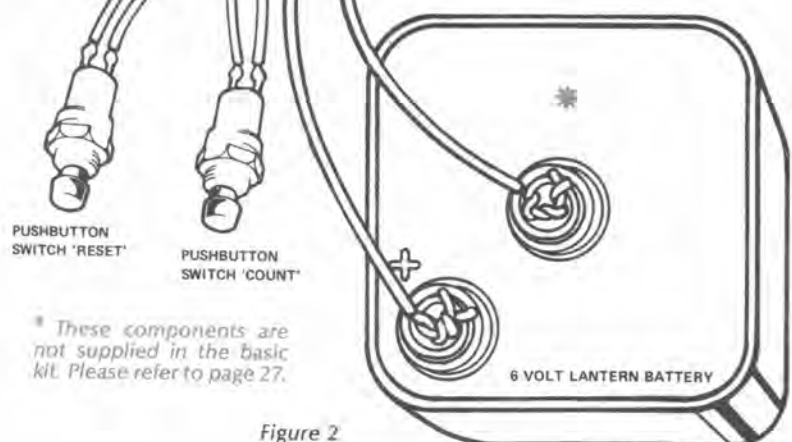
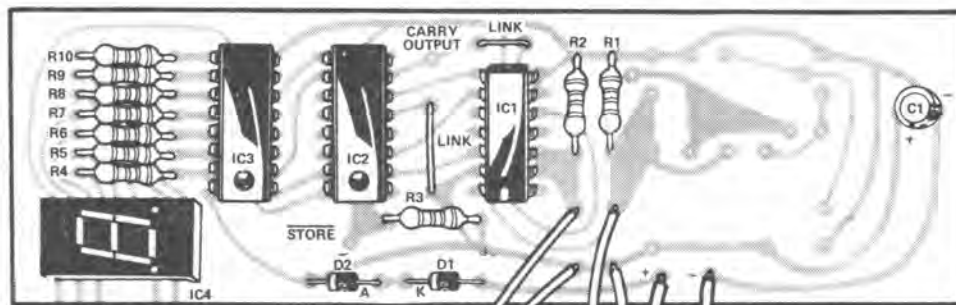

Figure 3

Figure 2

\* These components are not supplied in the basic kit. Please refer to page 27.



# putting it together . . .continued

Use red for the positive lead, and black for the negative.

- (8) Solder on the two pairs of wires for the push button switches, and solder the switches to the other end. To avoid mistakes, it is always a good idea to use two wires the same colour for one switch, and two wires another colour for the other switch.
- (9) Go back over your soldering carefully, not only checking that every component lead has been properly soldered, but even

more importantly that you haven't bridged any pads or tracks together, especially around the IC's where this is very easy to do. Check all your components and positions, at the same time.

- (10) Connect the battery (take care with the polarity – the battery is marked with a + and – symbol). The LED display should come on, reading any number (it possibly read the number of times the wire 'bounced' on the spring contacts of the battery as

you put it on. You won't have realised you were doing it, but you were!)

- (11) Press the 're-set' push button (PB2) and the LED should display '0'.
- (12) Press the 'count' push button (PB1) and the LED should display a different number each time you press it.
- (13) The blank areas of the PCB are for the 'de-bounce' circuitry, which is described in '**What to do next**'.

## how it works

The counter module is a typical arrangement, consisting of a counter IC, a latch, a decoder/driver and finally a seven segment LED (light emitting diode) display.

We'll see what happens with each of these in turn in a moment, but first a word of explanation about the power supply used in this project.

You will have noticed by now that all other projects use a 9 volt battery or a 9 volt plug-pack adaptor. However, the LED counter operates from a 6 volt lantern battery.

The reason for this is that the integrated circuits we use in this project (called TTL IC's, which stands for Transistor-Transistor Logic), require a power supply very close to 5 volts. In fact, their specifications call for a supply variation no wider than 4.75 to 5.25 volts. Outside these limits, the IC's are likely to be damaged.

A further consideration is the amount of power required. Apart from the LED display itself, which needs about 150mA when displaying '8' (all digits lit), the TTL IC's are themselves fairly greedy: between them, the three ICs may draw as much as 200mA. (Later IC's such as CMOS, don't draw anywhere near as much current, but as you will remember they have to be

handled very carefully). TTL's are more robust. So we need a supply capable of supplying 5 volts at up to 350mA. Apart from the voltage problem, a small 9V battery would curl up its toes if asked to supply this amount of current!

A 6 volt lantern battery is a different proposition. It can supply the current if required, (although in most cases the current drawn would be around 200mA maximum). And because the voltage is so close, this problem can be easily overcome.

So we use a 6 volt battery, but in series we put two silicon diodes. As you will remember, there is a voltage drop of around 0.6 volts across a silicon diode, so across two diodes we 'lose' a little over 1 volt. Subtract that from 6 volts: a little under 5 volts – right on target!

Now back to the circuit proper: we start off with a push button feeding pulses into a 7490 decade counter. It is called a decade counter because this IC counts to 10. But it doesn't count in decimals (0, 1, 2, 3, 4, etc, up to 9,) it counts in 'binary': a code based on two. (Decimal numbers are very easy to deal with in digital circuits, because there are only two 'values' in any binary number, a '0' and a '1'. These two values can be

called anything you like: off and on, high and low, etc, etc: the point is there are just two levels for a circuit to be able to recognise).

In a pure decimal counting system, a circuit would have to be able to recognise 10 different values. This can lead to very high error rates.

So the 7490 counts the decimal pulses in a binary code, and this binary code is fed to the outputs. The 7490 counts from 0 to 9, then on the 10th pulse, the internal circuitry of the IC re-sets it, so it starts at '0' once again. The 'carry output' line is connected to the output which goes high on the eighth and ninth pulses: on the tenth pulse, when this output goes low again, the next counter registers the pulse. (TTL IC's like the 7490 transfer information on the downward-going edge of the pulse).

The outputs from the decade counter are fed into a 7475 'latch' IC. All this IC does is store the outputs from the decade counter, so we can see exactly what happens at any given time. There is a point on the circuit (and PCB) marked STORE. This is normally tied to the positive supply rail via a resistor; however, if there was a push-button switch connecting this point to

*The circuit of the basic counter, with single push-buttons for both count and reset functions. Modifications can be made to eliminate the effects of contact bounce with the circuit on the next page.*

\* STORE. Leave unconnected if not wanted; connect to earth when wanted.

† CARRY OUTPUT. Use to link up with next counter module if required.

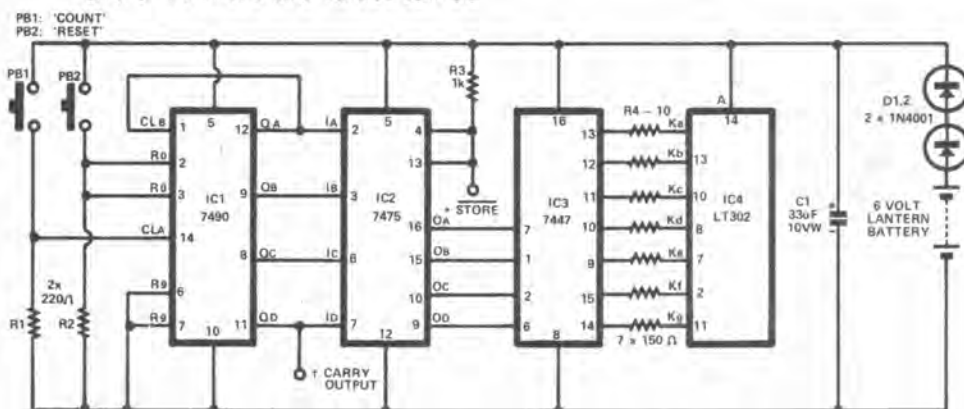

Figure 4

...continued

the negative supply rail as well, each time the button was pushed, the latch would stop accepting information from the counter, and display what was stored in it at that particular time.

A good example of a typical 'store' control involving a latch is a 'lap timer' on a digital stopwatch. The counter continues timing, but the display can be frozen for a brief period so the lap time (part of the overall time) can be read without stopping and starting the stopwatch, and thus losing the correct time.

In the same way, once the 'store' control is released, the latch immediately reads the latest output from the counter IC, and up-dates as necessary.

We could, in fact, have left the latch out of the circuit: however, for its low cost and possibilities for experimentation it gives, we thought it a worthwhile addition.

From the latch, the four binary outputs are fed into an IC which not only decodes the four binary inputs, it re-encodes them so that when they are fed to a LED display, they light up the correct segments.

Turning our attention away from the decoder for a moment, you can see that a LED readout is actually made up of seven different LEDs (called segments) arranged to form a pattern like an '8'. These are normally labelled 'a' to 'g'. (See 'components' section).

If, for example, we want the number 1 to light, we could get segments b and c, or f and e, to light (in practice, it is normally b & c that form a '1'). Or for a '3', segments a, b, c, d & g would light. So depending on which segments are lit, we can get all of the numerals 0 - 9, and, if we wanted them, quite a few letters as well.

In the particular LED display we use, all the anodes are joined together, and connected to the positive supply. So all we need do is connect the cathodes to the negative supply (via a current limiting resistor, of course).

Back to the decoder. If the input from the latch read 0101, the decoder would know this meant decimal 5 - and so cause its a,c,d,f and g outputs to go low - allowing current to flow through these LEDs, lighting them. Thus the display would read '5'.

So with a couple of low cost IC's and a number of LEDs built into a small package, we can make a counter that even a few years ago would have taken hundreds of transistors, diodes, and other components to even try to duplicate!

## what to do next

As we described in the introduction, there is some additional circuitry you can add to eliminate the effects of contact bounce in the push button switch. If you don't wish to fit this, skip this section; go on to where we mount the LED Counter in its box.

These additional components will be needed (they are **not** supplied with the kit).

### Resistors:

- R11 1k ohms
- R12 10k ohms
- R13 10k ohms
- R14 1k ohms

### Capacitors:

- C2 33uF, 10 volt electrolytic

### Semiconductor devices

- TR1, TR2 DS548 or similar NPN transistors

Figure 5

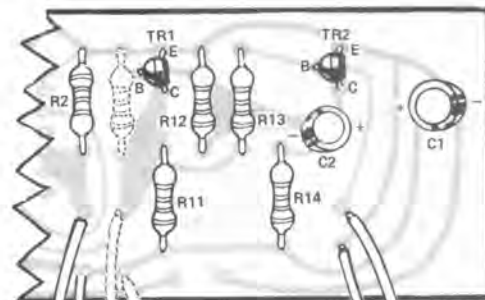
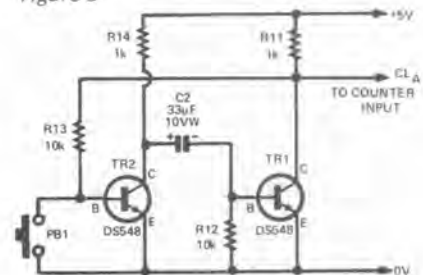

- (1) Use the supplementary drawing showing the end of the PCB we didn't use before. You will notice two components are shown dotted: the 'count' push-button and R1. Remove both of these from their present positions; keep the switch but you can discard the resistor.
- (2) Mount the four new resistors (R11 to R14) as shown, along with the new electrolytic capacitor (C2). Solder these components in, and remove their pigtails.
- (3) Solder in TR1 and TR2. Double check their orientation.
- (4) Now solder the wires to PB1 into their new position, near R14.
- (5) Make one last check of your

'RESET'

Figure 6

soldering and component positions, before re-connecting the battery.

- (6) The LED display should come back on again as before, and reset to zero as before. However, when the counter button is pressed, the count should advance by only one number for each pressing.

## how the 'de-bounce' circuit works

The push-button is isolated from the de-bounce output by TR2 and TR1. The output is normally 'high', because TR1 is not conducting. Therefore its collector is virtually at the supply voltage.

TR2 is normally conducting; therefore its collector voltage is low.

When the push button is pressed, it shorts TR2's base to the negative supply. This turns TR2 off, and its collector voltage rises from near zero to almost the positive supply voltage.

C2 starts to charge to this voltage, via R12 and the base/emitter junction of TR1. This turns TR1 on, dropping its collector voltage to near zero. The counter 'sees' this voltage drop as an input pulse.

C2 takes a short time to charge, by which time the contacts of the push button will have stopped bouncing. Quite soon, the capacitor reaches a state of charge where its charging current drops below the level required to keep TR1 on. TR1's collector voltage reverts to the 'high' state.

Even if the button is held down, TR1 stops conducting once C2 is charged. So it doesn't matter how long the button is held: there will only be one output pulse generated by each push of the button. Once the button is released, TR2 conducts again, discharging C2 and making itself ready for the next push of the button.

# what to do next . . .continued

## Putting the counter in a box

As we mentioned in the introductory notes, the PCB can be mounted in a box by itself, or a number of boards can be mounted side-by-side for a multi-digit display.

If just one board is required, there is no problem: just slot it in, and fit the switches wherever you like. You can even add a socket for the connecting wires to the battery if you wish.

If you are fitting more than one PCB, there won't be much room in the box for push buttons and sockets.

Especially if you want a four digit display (about the maximum number of PCB's you can fit into the H-2753 Zippy Box).

However, this may not be too much of a problem: if you're building up a three or four digit counter, you probably have some specific use in mind for it and may not need the push buttons on the box at all.

## Connecting the PCB's together

On the PCB layout drawing, you will notice a pad marked 'carry output'. This is the pad used to connect one PCB to the next. Obviously, only the first PCB will require the de-bounce circuitry: the carry output does not suffer from this problem!

Similarly, only one re-set button is required for any number of pcb's. Simply connect a wire from the 'R2' side of the push button to all the other boards; it solders to the pad where a wire to the push-button would have gone.

Take the wire from the 'carry output' to the pad which would have taken the wire from the push-button (this pad also connects to R1 and pin 14 of the 7490 IC, so identification should be no problem).

Any additional boards are connected the same way. In theory, there is no limit to the number of digits you can have; in practice, however, space starts to become something of a problem after the first couple of dozen or so . . . (not to mention a power supply!)

## Triggering the counter

The push button switch can be replaced by any number of mechanical or electronic triggering methods. For example, our drawing at the beginning of the project shows a slot car lap counter. Instead of manually triggering the counter as shown, why not have a light beam across the track and a light activated switch with the relay triggering the

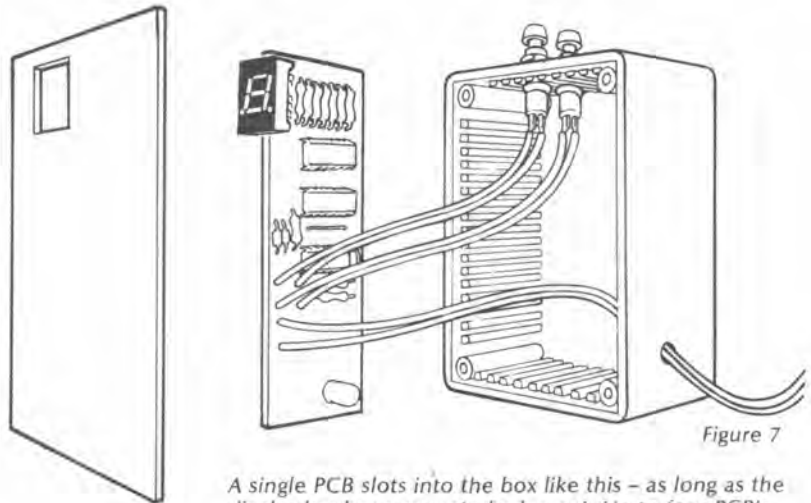

Figure 7

A single PCB slots into the box like this – as long as the display has been mounted edge on! Up to four PCB's can be mounted side-by-side if the push-buttons are not put in the position shown.

counter. It's easy to work out how to do it!

The same idea could be used as a 'people counter', where a light activated switch across a doorway records the number of times the beam is broken as people enter. (Don't put

it too low: you'll be counting legs and get double the number!)

A touch switch could be used to trigger the counter – or a sound operated switch. In fact, anything which gives the equivalent of switching could be used.

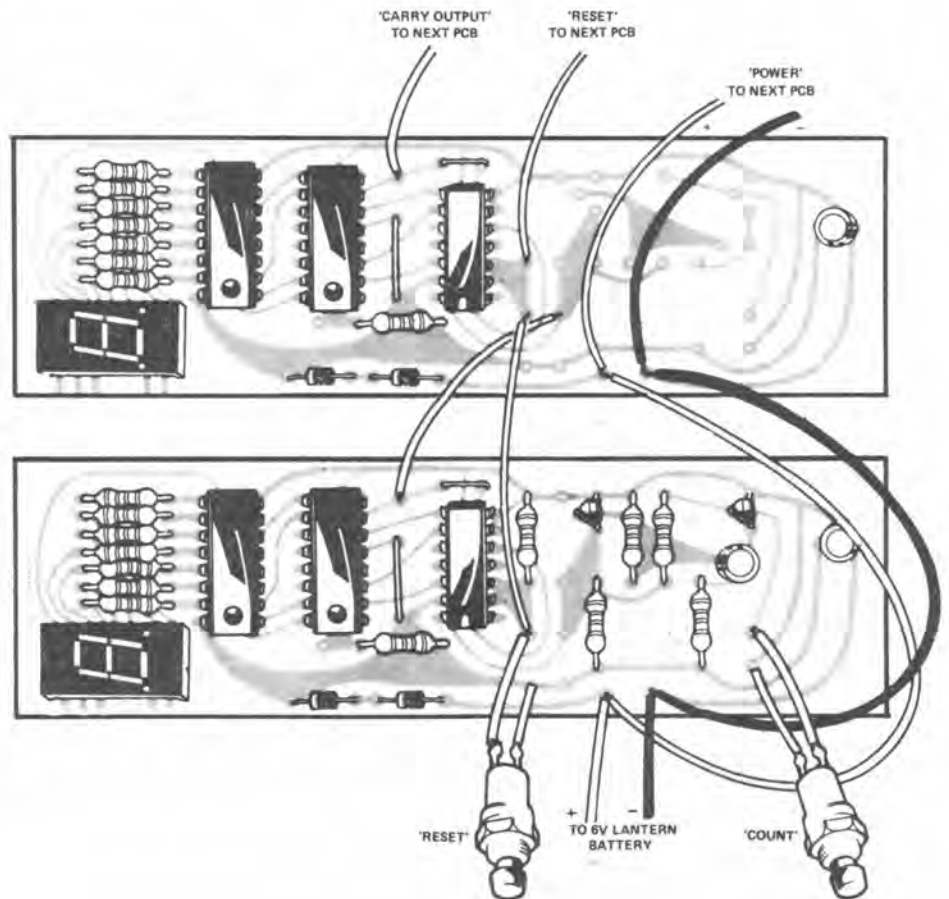

Figure 8

# about the 'binary' system

You will have noticed in the LED Counter project that we talk about 'binary' arithmetic. Do you know what this means, and how it is used?

In the number system we use in everyday life, we use ten symbols: 0, 1, 2, 3, 4, 5, 6, 7, 8, 9 to represent a certain numerical quantity. If the quantity is greater than any of these symbols will allow, we combine them to form a group of symbols, with the position of each symbol within the group having a meaning, as well as the symbol itself. Because there are ten symbols, this system is called a 'decimal' system, or a system to base '10'.

The reason we use a system based on ten is probably because we have ten fingers: but it is quite possible to count using other systems. Indeed, over the centuries various civilisations have used number systems based on 5, 12, 15 and many other numbers.

So it should come as no surprise to find that it is possible to count in a number system based on two: this is called the 'binary system'. The most obvious difference between a binary and decimal number representing the same quantity is that the binary number is much, much longer . . . and it has only two different digits in it!

There is a big advantage is having just two digits. These are very easy to represent electronically. By convention, when talking 'in binary', we call the first digit '0' and the second digit '1', but we could (and do) call the other things: 'off' and 'on'; 'high' and 'low'; 'open' and 'closed' for example. Electronic circuitry to represent just two states is very easy to make, and it can be made with high accuracy – much better than for a circuit needing to recognise ten states, as it would if it worked in pure decimals.

Recognising and working with binary numbers is just as simple as working with decimal numbers (if not simpler!) To see what we mean, let's examine the same number in both decimal and binary notation: decimal 1387 (which

can also be written  $1387_{10}$ , meaning 1387 to base 10), or binary 10101101011 (or  $10101101011_2$ ): we said that binary numbers are a little longer than decimal numbers!

Refer to the tables at the bottom of the page. They show both these numbers – let's look at the decimal one first.

Each digit in a decimal number has a 'weight': depending on its position. Each digit to the left is one power of ten higher than its right-hand neighbour.

So the number  $1387_{10}$  really means: 'multiply 7 times 1; 8 times 10; 3 times 100; 1 times 1000; then add them all together'.

Now the binary number. It means just the same thing: but is actually simpler because there is no multiplication needed: each digit represents a power of two, or zero.

So that huge number really means, quite simply, 'add together  $1 + 2 + 8 + 32 + 64 + 256 + 1024$ '.

See how it works? It really is very simple!

## Converting one to the other

It's easy to convert a binary number to decimal: we've just done it! To start off, you'll find it much easier to write down the number in a table form, just as we have done below. Then list the powers of two starting from the right (don't forget  $2^0$  is first – and any number to a power of '0' equals 1).

Now, let's try converting a decimal number into binary. There are a couple of ways to do this, but there is a way for beginners which is very simple: all you need to do is know how to divide by two! It works like this:

Take the decimal number, and divide it by two. If there is a remainder (in other words if the decimal number was odd) write down a '1' on the right of your sheet of paper (so you can write more

numbers down on its left). If there was no remainder, write down a zero.

Now keep on repeating the division by two of each answer you get. Once again, if there is a remainder, write down a 1, no remainder, write down a zero. Keep on writing the numbers leftwards across the page, until you can't divide any more. If there was a remainder left over (it would have to be 1!) write down a 1, if not forget about the last zero. That's your binary number!

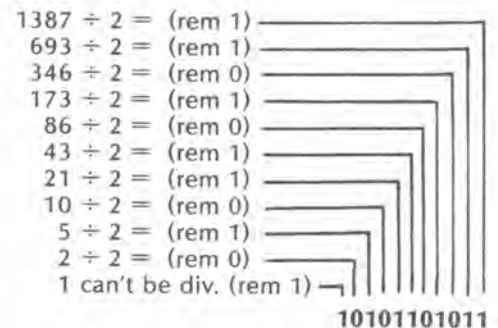

## Addition and subtraction:

It's just the same as decimal arithmetic. You simply add the digits together, and if the number is greater than the base (in this case 2) you 'carry' the extra digit over to the next column. Subtraction, of course, is the reverse procedure.

## Multiplication and division

While they are the same in theory, most digital circuits don't actually multiply and divide. To save memory and time, they use special circuitry: to multiply 50 by 20, a computer might add 50 to itself 19 more times (all in binary, of course!)

However, for the sake of the exercise, binary arithmetic is basically the same as digital arithmetic.

$(10^3)$	$(10^2)$	$(10^1)$	$(10^0)$	=
1	3	8	7	

$10$

$1 \times 10^3 + 3 \times 10^2 + 8 \times 10^1 + 7 \times 10^0$

OR

$1000 + 300 + 80 + 7 = 1387$

$(2^{10})$	$(2^9)$	$(2^8)$	$(2^7)$	$(2^6)$	$(2^5)$	$(2^4)$	$(2^3)$	$(2^2)$	$(2^1)$	$(2^0)$	=
1	0	1	0	1	1	0	1	0	1	1	

$2$

$2^{10} + 2^8 + 2^6 + 2^5 + 2^4 + 2^3 + 2^1 + 2^0$

OR

$1024 + 256 + 64 + 32 + 8 + 2 + 1 = 1387$

# project number twenty

## Integrated Circuit Short Wave Receiver

Imagine tuning in to the world with your own short wave receiver! It's easy with this simple project. It's simple to build, but uses a very modern C-MOS IC to provide enough amplification to drive a loudspeaker. You can use it to tune short wave broadcasts from other countries, listen to amateurs talking to each other, learn Morse code from slow Morse transmissions . . . Compared with the price you would pay for other short wave receivers, it's a bargain! And you'll be able to tell everyone you built it yourself.

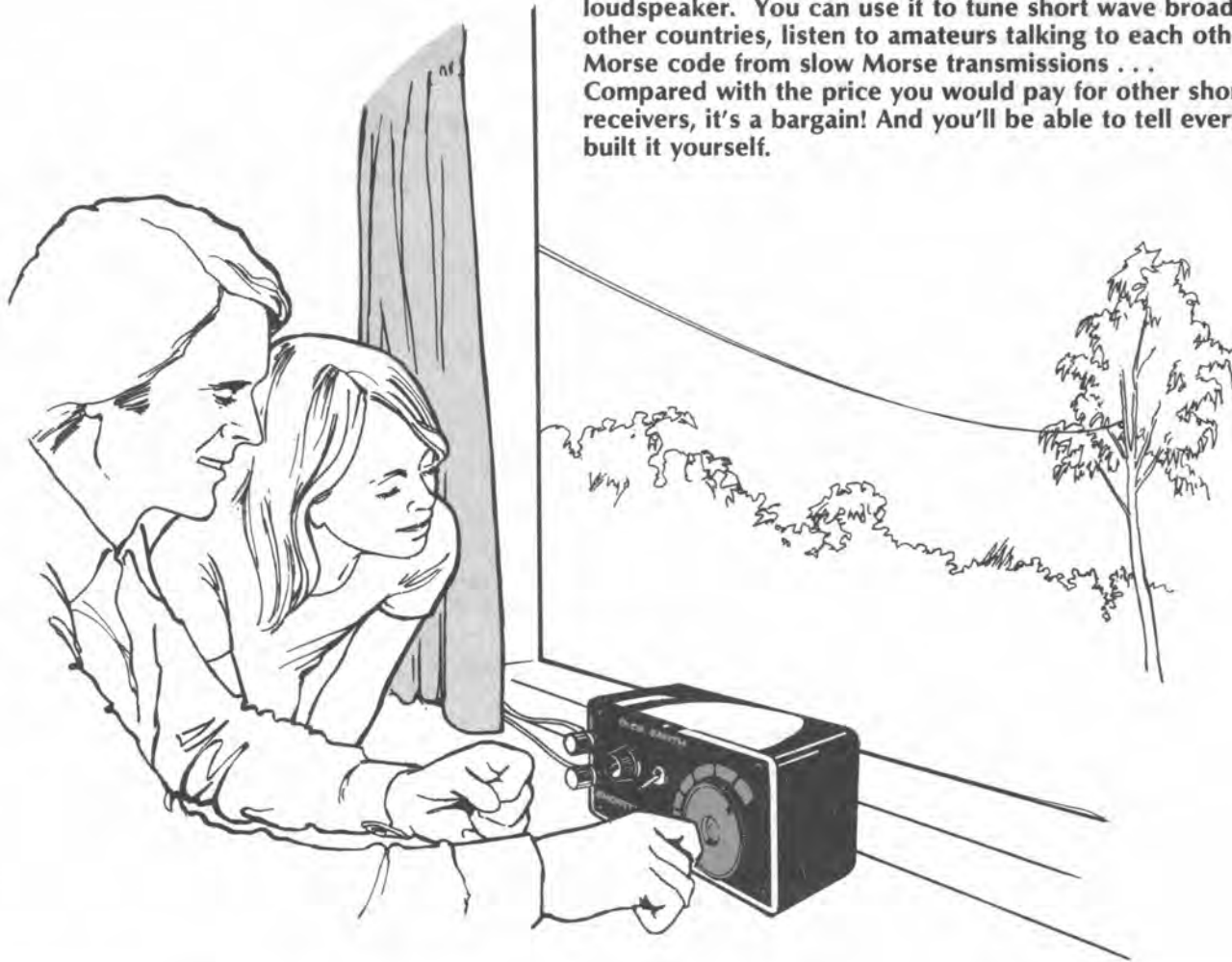

### you will need these components

#### Resistors:

R1 47k ohms  
R2 1k ohms  
R3 1M ohms  
R4 20M ohms  
R5 4.7k ohms  
R6 20M ohms  
R7 10M ohms

RV1 470k (or 500k) trim pot

Note: To obtain R4 and R6, the two 20 megohm resistors, wire two 10 megohm resistors in series. There is room allowed for two resistors in these positions on the printed circuit board.

#### Capacitors:

C1 .001uF ceramic  
C2 10pF ceramic  
C3 .0047uF polyester (greencap)  
C4 10uF 10V RB electrolytic  
C5 .0047uF polyester (greencap)  
C6 .0022uF polyester (greencap)  
C7 220pF ceramic  
C8 .0022uF polyester (greencap)  
C9 220pF ceramic  
C10 10uF 10V RB electrolytic  
C11 470uF 16V RB electrolytic  
CV1 60 - 160pF tuning capacitor

#### Semiconductor Devices:

D1 Signal diode OA91  
TR1 NPN transistor DS548 or similar  
IC1 CMOS integrated circuit 4007

#### Miscellaneous:

L1 Coil from hook-up wire – See **Putting it together**  
T1 1k ohm to 8 ohm audio transformer  
8 ohm loudspeaker  
Battery snap, solder, hook-up wire

You will also require a 9 volt transistor battery (not normally supplied with a kit) or some other 9 volt DC power supply.

A suitable mounting board or printed circuit board of correct design (DSFW 2 K-2640 **Short Wave Radio** kit contains the correct PCB).

# putting it together

- (1) If you have purchased a kit (Dick Smith Cat. K-2640 or similar), check off the components against the above list to make sure they are all there and are the correct types and values.
- (2) If you have not purchased a kit you will need to obtain the components listed and either make a printed circuit board using the component position drawing as a guide, or use a perforated or tracked board.
- (3) Mount the components as shown in the component position drawing. Place and solder the resistors and capacitors first, taking extra care with C4, C10 and C11, the electrolytic capacitors as they are polarised. Check that all the components are positioned neatly and properly dressed before soldering them in.
- (4) Solder in RV1, the 470k triptop. On the layout below this has been shown as a potentiometer with flying leads – as we have mentioned before, the kits do not have potentiometers supplied as some constructors will not want to make more than the bare PCB. Solder the triptop into the PCB in place of the three wires. If you want to substitute a proper potentiometer later, wire it as shown below.
- (5) Solder in the variable capacitor, CV1. You will note that only two of the three terminals are actually used. Also solder in T1, leaving the centre tap on the 1k side unconnected: bend it up out of the way or snip it off.
- (6) Connect and solder D1 the signal diode, making sure that you have it correctly polarised – remember that the banded end is the cathode (K). Solder in TR1, ensuring that the polarity is correct, using a heatsink clip to prevent damage from overheating.
- (7) Make a coil by winding 18 turns of plastic coated hook-up wire around a plastic ball point pen case or something similar and solder the leads to the pads marked on the PCB so it is parallel with the tuning capacitor. The combination of the coil and capacitor form the tuned circuit of your radio.
- (8) Solder on the battery snap and speaker leads. The speaker is not polarised but the battery is, so

take care to make sure that the leads are the right way around – the red (positive) lead goes to the pad marked '+' and the black lead to the negative pad marked '-'.

**DO NOT CONNECT THE BATTERY!**

- (9) Now the CMOS integrated circuit. Use extreme care in the handling and soldering of this device as it is sensitive to static electricity and may be damaged by stray voltages. Do not remove the special conducting foam it is packed in until the moment you are ready to place it in the PCB and solder it. Do not touch the pins of the IC. Well! If you are still game to touch the IC after all of these warnings, carefully remove the foam and place the integrated circuit into the holes on the PCB. Make sure that you have it the right way around the first time as removing and replacing it greatly increases the chance of damage. Use a heatsink clamp when soldering and make sure your soldering iron is properly earthed. As mentioned in other projects,

• These components are not supplied in the basic kit. Please refer to page 27.

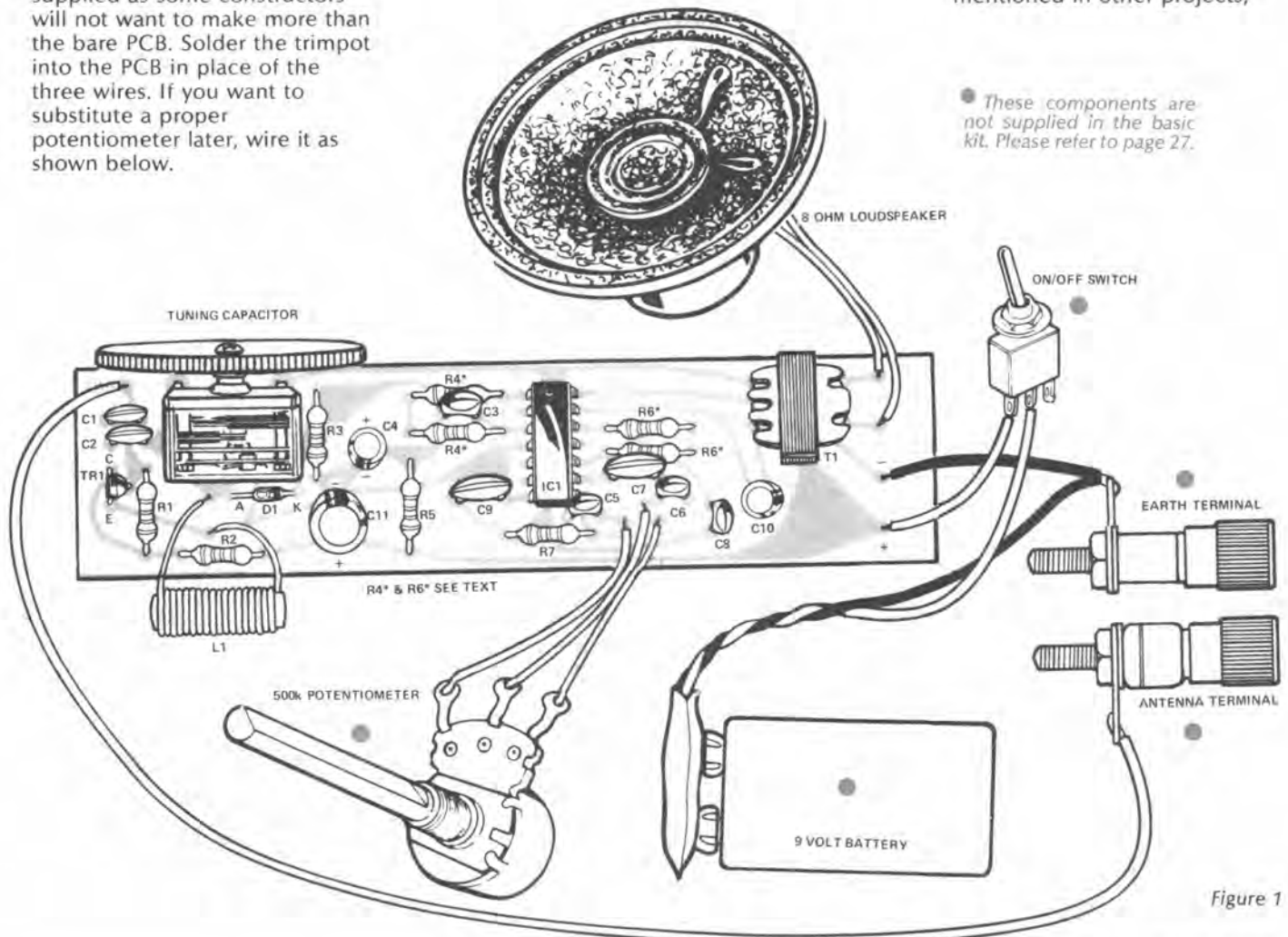

Figure 1

# putting it together . . .continued

it would probably be worth your while to solder in an IC socket or use Molex pins first to reduce the chance of damage.

The reason we are using such an apparently delicate device is that it is a very efficient IC, doing the required job very well and using little power so that the battery will last much longer.

- (10) Clip off excess wire neatly, making sure that all of the soldered connections are properly made.
- (11) Check all components to ensure correct position and polarity before connecting the battery.
- (12) Connect the battery and tune the radio by varying CV1 until you pick up a station.
- (13) Read on to 'What to do next' for exciting ways to improve the performance of your radio.



Figure 2

## how it works

For a detailed explanation of radio transmission and reception processes, see 'All About Radio' later in this book.

Radio waves of all frequencies are picked up by the antenna, and are amplified by TR1. These amplified signals are fed, via a capacitor which limits a lot of the lower frequencies, to the 'tuned circuit', consisting of L1 and CV1.

The tuned circuit acts like a short circuit to all frequencies except one. Varying the tuning capacitor alters this frequency, so we can choose the frequency we want by setting the tuning dial to that frequency.

So as far as 99% of the signals received by the antenna are concerned, this is the end of the road.

The single radio frequency current which was not rejected by the tuned circuit then passes through a diode detector – just like the one in a crystal

set. The detector chops off half the waveform (otherwise the two halves would cancel each other out). The half waveform contains all the audio information that was transmitted along with the RF carrier back at the station.

The half waveform is then fed into the first of three stages of amplification, inside an integrated circuit.

Along the way, the RF component of the half waveform is filtered out, as we don't need it any more. This leaves only the audio signal.

The integrated circuit itself is rather interesting: we use what is normally regarded as a 'digital' IC (one which operates in digital circuits such as computers), in a completely different way to normal: we use it as an amplifier.

In fact, inside the IC case are four individual circuits; we use just three of them. Each one increases the level of the signal, until the final stage where

there is enough level to drive a loudspeaker.

While the level is satisfactory, connecting a speaker to the IC would not make the IC very happy: it wants to work into a 'load' with a reasonably high impedance (resistance). So we give it one with the transformer T1. The current flowing in the primary of T1 induces a current to flow in the secondary: this is connected to the speaker and we can hear the result!

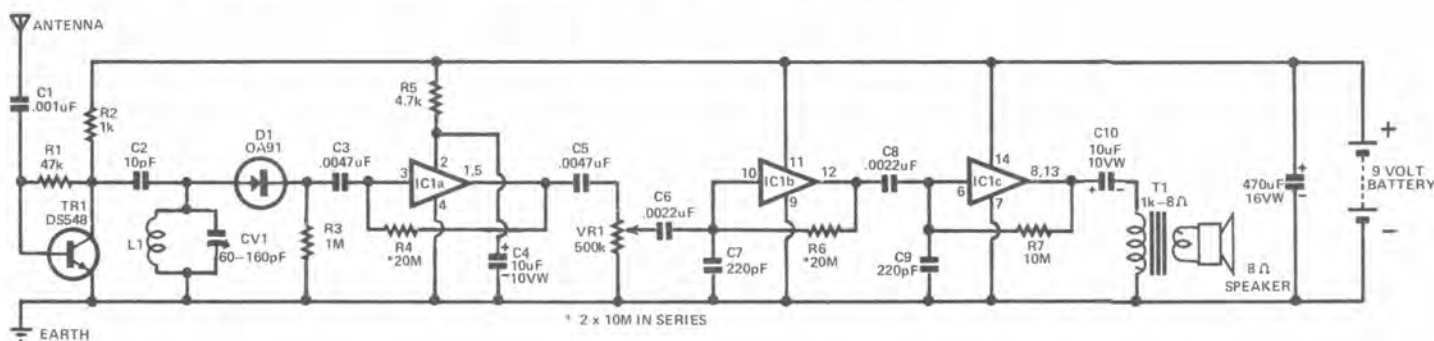

# what to do next

Because the slightest bump to the coil will cause the receiver to 'drift' (losing the station it was tuned to), the receiver should be mounted in some form of protective case. The PCB has been designed to allow 'no holes' mounting in a slotted Zippy box.

As shown in the component position drawing, when the PCB is mounted in a Zippy box, a power switch and normal potentiometer are added. Otherwise, changing the volume or turning the set on and off means taking the front panel off! You can also fit a socket for an external plug-pack adaptor at this time if you wish.

When the PCB slots in sideways into the box, the shaft of the tuning capacitor falls into just the right place so the tuning knob can be screwed on through the hole in the front panel.

The performance of this set is only as good as the antenna and earth system to which you connect it: for this reason, we have shown terminals for both the antenna and earth connections on the front panel.

If you use terminals, remember that the antenna terminal must be insulated from the front panel, and the earth terminal should connect to the front panel. When you buy a terminal, you will see how the in-built insulators can be arranged to allow for either insulated or shorted use.

Your antenna can be as simple as a length of wire dangling out your window, but for the best results, the antenna should be strung to some high point – a tree or post, for example. Keep it away from any power lines, for safety's sake.

While we're on the subject of safety, never use the 'earth' pin of a power point or extension lead as an earth connection for a radio, etc – on this radio or any other. The earth pin is provided for protection: if a fault develops in your house wiring or an appliance while you're plugged in, you may never build another project. By the same token, never connect an earth wire to a gas pipe: it is not only illegal, it can be very dangerous. (Imagine if lightning struck your antenna and melted the gas pipe. . .)

The best earth is probably your cold water pipe; alternatively, a metal stake driven well into soft, moist ground usually makes an acceptable earth.

The frequency your receiver will cover as described, with 18 turns on the coil, is approximately 11 to 35MHz. You can change this coverage by changing the coil – 80 turns will allow you to tune from around 6 to 11MHz. Even more turns will reduce the range even

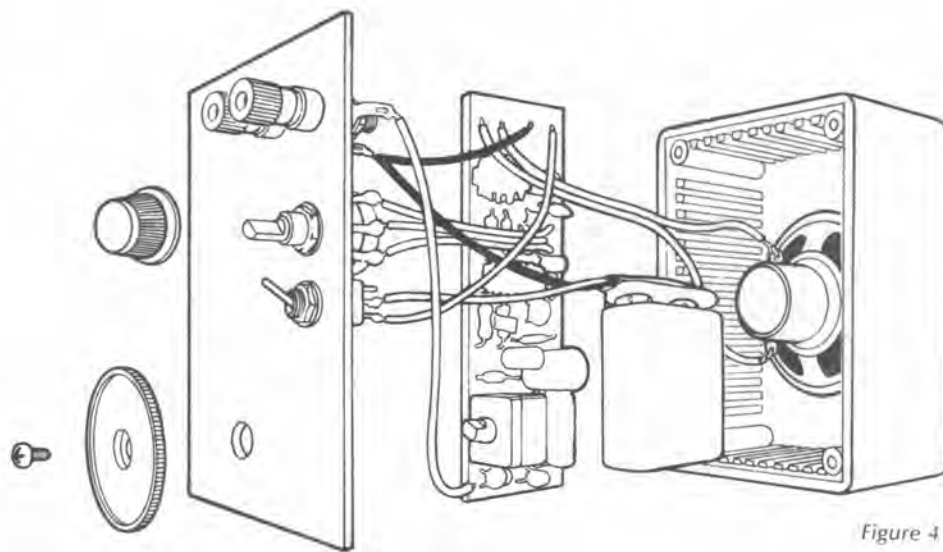

Figure 4

further. A smaller number of turns will increase the range: up to a point. Lesser number of turns are not as efficient.

Alternatively, you can try changing the variable capacitor to see what bands you can cover. While other variable capacitors may not fit in the box or even on the PCB, you can connect them via **short** lengths of wire.

If you wish, you can even try putting in a fixed value capacitor (of approximately the same value as the variable types; up to a few hundred pF) and connect a small trimmer capacitor in parallel to give you very fine tuning over a limited range.

There is very little you can do wrong in this section of the circuit that might cause problems: the tuned circuit is reasonably isolated by C2 and C3.

When you're tuning across the short wave bands, you'll probably hear some speech which you can't understand. This is almost certainly a special type of communication called 'Single Sideband' (SSB), and normally requires special circuitry to be able to listen to.

Or you may hear what is obviously Morse code, but is very difficult to

listen to. It seems to 'phut' instead of the tone you're more used to.

There is one easy way you can listen to SSB and Morse code on your shortwave receiver; get an ordinary battery operated transistor radio, place it close to your IC radio (the closer the better). Turn it on, but with no volume at all. When you tune your IC Shortwave Radio and hear one of the SSB or Morse stations, leave it tuned in, and slowly tune the transistor radio over its band.

You should hear your IC radio making whistling noises. If you tune the transistor radio **very** carefully so that one of the whistles just about disappears, you should be able to at least understand the SSB station, or hear the Morse as a tone.

It's not the easiest way to tune SSB or Morse: but it sure beats spending a couple of hundred dollars on a communications receiver to do it properly!

As you can see, experimentation with a circuit like this one can keep you going for a long, long time.

It's up to you!

## THE 'Q' CODE

When tuning over the amateur bands (and indeed some of the commercial bands) you might hear people talking or Morse code representing groups of letters starting with 'Q'. This is a shorthand way of sending and receiving information: common Q codes and their meanings are listed below. The Q code can either be a question (as below) or a statement: e.g. I am going QRT (I am stopping transmitting).

<b>QRA</b> What is your station?	<b>QRV</b> Are you ready?
<b>QRB</b> How far away are you?	<b>QRX</b> Wait briefly (e.g. QRX-1; wait 1 minute)
<b>QRC</b> What channel am I on?	<b>QRZ</b> Who is the station that's calling me?
<b>QRH</b> Does my frequency vary?	<b>QSA</b> What is my strength?
<b>QRK</b> What is my readability?	<b>QSB</b> Am I fading?
<b>QRM</b> Are you being interfered with (by other stations – man made interference)?	<b>QSL</b> Can you acknowledge receipt (QSL card – card for this purpose)?
<b>QRN</b> Are you troubled by noise or static (natural interference – lightning etc.)?	<b>QSN</b> Did you hear me on —?
<b>QRP</b> Can you reduce power?	<b>QSO</b> Two-way communication between stations.
<b>QRT</b> Shall I stop transmitting?	<b>QSY</b> Will you change to another channel?
<b>QRY</b> I am on standby unless messages are specifically directed to me.	<b>QTH</b> What is your location now?
	<b>QTR</b> What is the correct time?



# how to use your multimeter

So you've just arrived home from your local Dick Smith store with your brand new shiny multimeter. All you need now is to work out how to use it!

## Unpacking it and setting it up:

When you buy a multimeter, it is seldom ready for use. Almost always, batteries must be fitted, and in some cases, there is a protective wire link across the meter to remove.

Read the instruction manual carefully, and carry out any steps described. A word of caution: most meters are supplied with batteries, but sometimes these are not the best. As a meter is left unused for a long period, it is a wise investment to buy some fresh, well-known-brand batteries.

Your multi-meter will have a large scale area, a knob surrounded by figures, a small knob marked 'Ohms adjustment' or similar, and at least two terminals. If there are more than two terminals, look for the ones marked '+' and '-', or 'V-A-OHMS' and 'common'. In many meters, these terminals will be coloured red and black respectively.

Plug your test leads into the terminals: red into the red or '+' terminal, black into the black or '-' terminal. Turn the knob to one of the 'ohms' ranges and short the ends of the test leads (or 'probes') together. The pointer should move at least part way up the dial, perhaps right to the end or past it.

If it does, your meter is ready for work. Read on!

## What scales have you?

Most multimeters (even the real budget models) give you at least four different measurement options: DC voltage, DC current, AC voltage and Ohms. These are further divided into different ranges, to give more flexibility. The more expensive meters may also offer AC current measurement, and possibly other functions too.

Each of the ranges is represented by a scale on the meter face; though many of the scales may be shared. For example, you might read 0 - 2.5mA on the same scale as you read 0 - 250mA and 0 - 250 volts. These scales are linear; thus the divisions between markings remain constant. All you do is apply the right 'units' to the scales to work out the exact figure: these units are given to you alongside the pointer on the 'range' switch.

There might also be a strip of mirror on the scales. The purpose of this is to allow you to line up the pointer with its reflection, eliminating 'parallax' errors (errors caused by viewing the pointer from an angle).

There may also be other ranges marked on the scale, which are obtained by using

different terminals to the normal ones. An example of these are on the meter above: a 0.1V (50uA) DC terminal and a 1000V AC terminal, which are not affected by the 'range' switch. These special terminals are connected direct to the meter in some cases, and must be used with extreme care.

## Measuring DC Current:

The important thing to remember when measuring current is that the meter must be placed **in series** with the circuit. This means that the circuit must be broken, with the meter leads connecting the two sections together.

Normally, a circuit is broken by unsoldering a wire or component; unfortunately, this is not always possible. For instance, if you want to know the current flowing through a certain PCB track, you must break the track (shudder!) to include the meter in series. This can usually be done by cutting the track at a narrow point with a very sharp blade. When the measurement is finished, solder can be flowed over the knife cut to restore connection. (You might even need to put in a small piece of hookup wire to assist the connection).

When measuring current, start with your meter on the highest range and work down. Stop when the pointer moves reasonably high up the scale.

It is also important that the probes are connected in the correct polarity. The red probe is connected to the more positive side of the circuit; the black probe is connected to the more negative side.

If you find the pointer swings the wrong way, reverse the probes.

## Measuring AC Current:

Your meter may not have provision for AC current measurement, particularly if it is an economy type. If it does, measurement is basically the same as for DC: except there's no need to worry about polarity. Once again, start with a high range and work down to the correct one.

## Measuring unknown current

If you don't know whether AC or DC is flowing in the circuit, don't worry! If the meter is set on DC, and you have AC flowing, both halves of the cycle will tend to cancel each other out. Your pointer may 'shudder' a little. If you are trying to measure DC on an AC scale, nothing will happen if the current is steady. If the current is varying, there will be



some reading, but it will be erroneous.

## Measuring DC Voltages:

Measuring voltages is exactly the opposite to measuring current: the meter is placed **in parallel** to the circuit or component being measured. Once again, however, polarity has to be observed. Red (positive) to the positive side of the circuit, black (negative) to the negative.

And again, if you don't know the voltage, start on the highest range and work down.

## Measuring AC Voltages:

It's just the same as measuring DC voltages: just follow the same steps and remember that the meter must be placed in parallel.

A word of explanation here about what the meter actually reads: As you know, an AC wave starts at zero, rises to a peak, falls back to zero, and then does the same thing in the other direction during one cycle.

A moving coil meter (as 99% of multimeters are) indicate what is called the 'rms' value of the voltage. This value (which stands for root mean square) is more or less an average, taking into account the fact that the voltage is always changing.

The 'rms' voltage has exactly the same 'work value' as a DC voltage of the same magnitude. In other words, if you supplied an electric heater with 240 volts rms, and then 240 volts dc, the heater would give out the same heat in both cases.

If you want to convert the 'rms' value your meter reads, to the 'peak' value (the maximum

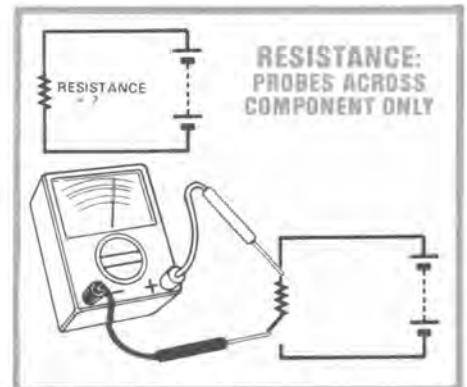
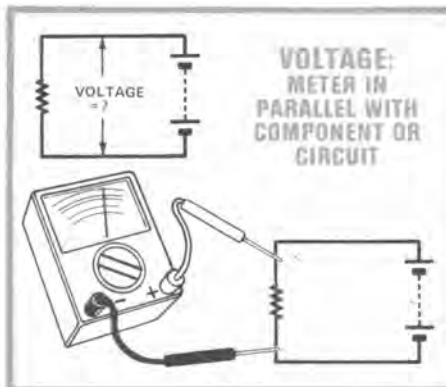
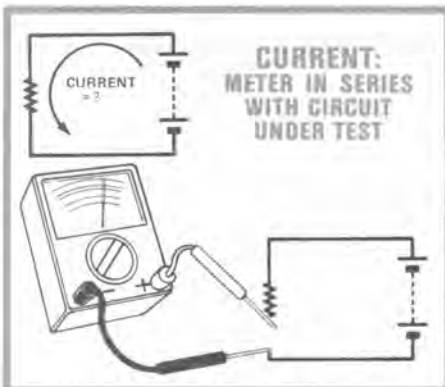

voltage reached in the cycle) you have to multiply by 1.4142. Conversely, the rms voltage is 0.7071 the peak voltage.

#### Measuring resistance:

When measuring resistance, it is important that the component you are reading is not affected by other components in the circuit. There is no point in measuring a resistor when there is another resistor in parallel which is interfering with the reading.

Therefore it is normal practice to remove one end of the component under test from the circuit to avoid any possible influence. Another wise move, even if you disconnect one end of the component, is to make sure power to the circuit is turned off.

Before commencing measurement (and each time you change resistance ranges) you must 'zero' the meter. This involves adjusting the knob on the meter so that the pointer reads exactly zero ohms when the probes are shorted together.

Select the lowest resistance range and zero the meter. Then place your test probes across the resistor (or other component you are testing). If the pointer doesn't move (or barely moves) switch up to the next range, and the next, until the pointer is in the last third of the scale. This is the area where best reading accuracy is obtained.

If the pointer reaches, or over-shoots zero, back off one range. Re-zero the meter and then read the value from the 'ohms' scale. Multiply the reading from the scale to the multiplier indicated by the knob: for example, if you read 15 on the scale, and the knob points to 'x100', the actual resistance is 15 x 100 or 1.5k

#### Checking transistors and diodes

While not a perfect check, a multimeter can usually give you a 'go/no go' test on most diodes and small signal transistors. (Testing power transistors is not quite so simple, as the results can sometimes be misleading).

**Testing diodes:** This is very easy. A diode should conduct in one direction only: if you set your multimeter to a low ohms range (say x10) and place your probes on the on each end of the diode one way, the meter should read fairly low. Reverse the probes, and the meter should read fairly high. If both these checks are ok, then basically so is the diode!

Zener diodes can also be checked the same way. You can't tell their voltage, but you will at least have a go/no go indication.

**Testing transistors** Because transistors are basically two diodes in one package, we can check them in a similar way to diodes. We can also check for 'punch through' from collector to emitter.

Switch to a low ohms range, (eg x10) and connect the probes to the emitter and collector. Read the meter, and reverse the probes and note the reading again. Both should be high. If so, continue. If not, you should probably throw the transistor away!

Switch to a high (x1000) range, and connect one of the test probes to the transistor's base. Connect the other probe to the emitter, then collector, noting the readings. Both readings should be roughly the same; high or low, it doesn't matter (but remember which!)

Now swap the probe on the base with the other, and do the same check. The readings should still be roughly the same, but opposite

to the last check. If the last readings were both high, these should be both low, and vice versa.

If these tests are ok, the transistor is also probably ok. By the way, you can work out whether your transistor is an NPN or PNP with these checks: with the black lead on the base and both readings low, the transistor is an NPN type. With the red lead on the base and both readings low, the transistor is a PNP type.

#### POINTS TO REMEMBER:

- Meter in series for current
- Meter in parallel for voltage
- Meter across component only when measuring resistance
- Start on the highest range and work down
- Zero the pointer when changing to any resistance range
- Replace the batteries if you cannot zero pointer
- Use the mirrored scale to avoid parallax errors
- Swap the probes if the pointer swings backwards
- Take care of your meter!

## what's inside a multimeter?

As you can see from above, the multimeter is very versatile. But do you know how it performs all those functions?

The heart of the multimeter is the meter movement itself. This consists of a coil of wire, suspended on an axle, in a magnetic field from a permanent magnet. If a current passes through the coil, another magnetic field is set up. The two fields repel each other (just like two magnets can repel each other), and the coil tries to move.

The only way the coil can move is to rotate on its axle. Attached to the axle is a spring, and a pointer which can move over a scale. Because of the spring, the amount of rotation of the coil will vary precisely with the amount of current flowing through the coil. So the scale can be graduated directly in units of current.

The current through the coil is, however, very, very small. In a modern multimeter, it takes just 50µA to make the pointer travel from one end of the scale to the other. (This is called full scale deflection, or fsd).

Obviously, a multimeter can measure a lot more than 50µA (many meters measure up to 10A – 200,000 times as much!)

Remember our discussion on voltage dividers at the end of project 12? If two resistors are connected in parallel, the current divides up in inverse proportion to their resistance.

Exactly the same thing happens with a multimeter. The switch connects various resistors in parallel with the coil so that the current between the coil and resistor divides. An average multimeter has a coil resistance of 2000 ohms: if a 2000 ohm resistor was connected in parallel, the meter would read full scale when 100µA was flowing. If a 0.1005 ohm resistor was connected in parallel, the meter would read full scale with a

current of 1 amp flowing! (Yes, resistors of this accuracy are required, and used, in multimeters!)

The resistors switched in parallel with a meter movement are called 'shunts' – they shunt most of the current past the meter.

Now, how about voltage? As we mentioned, a meter measures current. But the coil has a certain resistance, so from Ohm's law we know that to make this current flow a certain voltage has to be applied to the coil. With a 2000 ohm movement, it takes just 0.1V to make 50µA flow (for fsd).

It follows that if we add additional resistors in series, it will take more and more voltage to maintain that same 50µA current.

If we added a 2000 ohm resistor in series, the voltage would divide across each 'resistance' so there was still 0.1 volts across the movement with 0.2 volts applied. So the meter would read full scale. If we connected a 1,998,000 ohm resistor in series, we could apply 100 volts to the meter, and it would still only read full scale.

Of course, the pointer doesn't have to swing all the way; a lesser voltage will give us a lesser swing. So we can calibrate the scale directly in volts, with the maximum voltage being what that series resistor will allow for exactly full scale deflection.

The resistor in series is called a 'multiplier': it obviously multiplies the voltage required for full scale deflection.

#### Measuring resistance

A meter switched to the 'Ohms' scale is basically still a voltmeter; the difference being that the voltage which drives the movement comes from internal batteries rather than the circuit under test. (Note that a multimeter needs batteries **only** for resistance measurement – they can be

removed completely for current and voltage!)

As the battery voltage remains constant, any resistance which is introduced in series with the meter will reduce the current flowing, thus reducing the reading. The scale is calibrated directly in Ohms, and must be multiplied by the figure indicated by the switch pointer. The switch selects different multipliers so that very wide ranges of resistance can be measured.

We mentioned before the 'zero ohms' adjustment. All this does is 'fine tune' the multiplier so that effects of battery voltage and component aging can be countered. If the 'zero ohms' control cannot bring the pointer to the zero mark the battery should be replaced.

#### Meter sensitivity

All meters 'load' the circuit being measured. By this we mean that the circuit or component is affected by the current taken from the circuit to drive the meter movement – small though it be. For minimum loading, the 'sensitivity' of the meter should be as high as possible.

Sensitivity is quoted in 'ohms per volt': in general, the higher the better. A modern multimeter would have a sensitivity of around 20,000 ohms per volt DC (more than enough for the average hobbyist use).

What this means is that on each DC voltage range, the circuit 'sees' the meter as a resistor, having a value of 20,000 times the full scale voltage of the range: on a 1 volt range it would be equivalent to a 20,000 ohm resistor; on a 100 volt range it would be equal to a 2,000,000 ohm resistor, over the entire range.

AC sensitivity is always lower than DC: 7 to 10 thousand ohms per volt is typical. This is adequate for the hobbyist.

# understanding radio

In Fun Way Two, we introduced a type of radio transmission which is very much in the news, but is mysterious to most people. We are referring, of course, to 'FM' – frequency modulation. You will see that FM is not all that different to AM (which we used in Fun Way One) – but it does have several advantages in use. Let's see what their similarities and differences are:

## 'DC' and 'AC'

Radio really isn't all that mysterious: if you can grasp a few basic principles, you're well on the way to understanding it!

You may have heard the expressions 'DC' and 'AC'. Perhaps you even know what they stand for: direct current and alternating current. But do you know what these mean?

When we connect a battery to a circuit, current flows. But it flows in one direction only: by convention, from the positive terminal, through the circuit and back to the negative terminal.

But current doesn't have to flow in one direction only. For example, when you turn on a light in your home, the current that causes that lamp to glow is actually changing direction – one hundred times every second! This is called alternating current: periodically, the current reverses direction of flow or **alternates**.

If you were able to measure the current, you would find that it follows a fixed routine. It would start off at zero, rise to a maximum, fall back to zero, then reverse direction, rising to a maximum, falling back to zero and reversing direction again. It would look something like the graph shown in figure 4. The 'cycle' would repeat over, and over again. If you counted the number of full cycles, ie each time the current started flowing in the same direction again, you would know the **frequency**. Frequency is the number of cycles per second. Current may range in frequency from just a few cycles per second – or **hertz (Hz)** to many, many millions of hertz.

Turning our attention away from AC & DC and frequency for a moment, let's go back to one of the components we used in our projects – the capacitor.

Remember a capacitor may be used to store electrical energy or "charge", in the form of an electric field. We can recover this stored energy by "discharging" the capacitor back into our circuit. But when we do this, we can never regain ALL of the energy we put into the capacitor. Some of it is lost, having been changed into other forms of energy during the very acts of putting the energy into the capacitor and getting it out again.

Some of the lost energy is converted

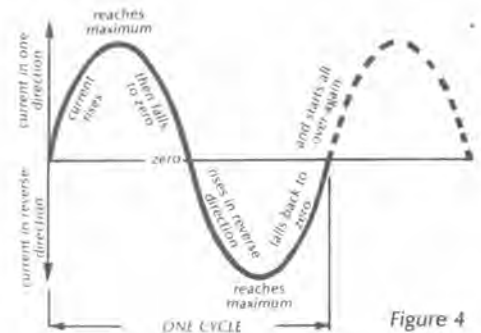
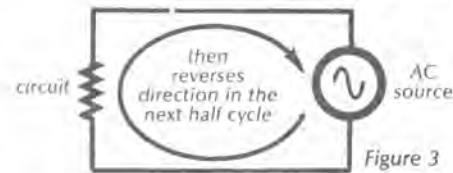
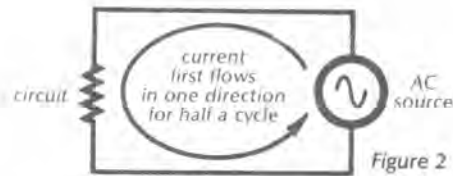

These diagrams show the difference between direct current and alternating current. Figure 1 shows DC: it moves in only one direction. Figures 2 and 3 show AC: changing direction each half cycle. If we plotted the current (or voltage) over a period of time, we would get the pattern shown in figure 4: one cycle of AC voltage or current.

to heat, by the various losses inside all practical capacitors. But the rest of the lost energy leaves in the form of electromagnetic radiation or **RADIO WAVES**, which radiate away in all directions. These waves are generated whenever an electric field is created, destroyed or changed – and also, it turns out, whenever the magnetic field of an inductor or coil is created, destroyed or changed.

If a capacitor or inductor is connected across a source of DC, there will be a single small "blip" or pulse of electromagnetic radiation produced as the electric or magnetic field is created. Similarly there will be a second small pulse when the fields are destroyed, by either discharging the capacitor or removing the current from the inductor.

But if the capacitor or inductor is connected across an AC supply, the field will be repeatedly built up and destroyed due to the alternating voltage and current. So a continuous stream of electromagnetic radiation is produced – with a frequency identical to that of the AC supply.

## The aerial

An **AERIAL** or **ANTENNA** is basically a special type of capacitor or inductor, deliberately designed so that it "loses" as much as possible of the energy fed into it as electromagnetic radiation. And it turns out that these specially

designed aerials are also good at **RECEIVING** electromagnetic radiation: when radio waves pass through them, tiny voltages appear across the plates of a capacitor type aerial, while tiny alternating currents are induced in the winding of an inductor type aerial.

An example of a capacitor type aerial is the old "long wire strung up between two poles", used with a good earth. Here the aerial wire itself forms one plate of the capacitor, while the earth or ground forms the other plate (that's why this type of aerial only gives good results when you have a good "earth"). An example of an inductor type aerial is the "loopstick" or ferrite rod aerial used in most modern transistor radios.

If the AC supply connected to an aerial happened to be an amplifier connected to a microphone, the radio waves produced would vary in strength and frequency according to the signals produced by the microphone. You might imagine, then, that it would be possible to set up a communication system using this scheme – with a receiving aerial and earphone at the other end. Possible, yes; but practical, no!

It turns out that to be efficient at the very low frequencies involved in audible sounds, aerials have to be enormously large: many kilometres long. Smaller aerials are so inefficient that they need huge amounts of power at the transmitting end, and

enormous amplification at the receiving end.

It just so happens, however, that as we increase the frequency, electromagnetic waves become easier and easier to radiate. So much so that by the time the frequency has reached a few hundred thousand cycles per second (hertz) we can radiate modest amounts of power, using manageable aerial systems, whose waves can travel over vast distances. Receiving them is not too difficult, either.

We call frequencies above the range of hearing **radio frequencies**: from around 20,000Hz to many, many millions of Hz. Above radio frequencies are heat waves, infra-red and visible light, ultra violet light, x-rays, gamma rays, etc etc. Yes, all these forms of radiation are electromagnetic in nature.

### The transmitter

A basic radio transmitter consists of a source of RF current (called an RF oscillator), an amplifier capable of handling the high frequencies involved, and an aerial. This is the basis of a Morse Code transmitter: the Morse key simply switches the RF oscillator on and off.

To transmit speech or music is slightly more difficult. If we look at an ordinary transmitter, such as you would find in a broadcast station, the RF oscillator keeps going all the time, putting out a signal called a **carrier**.

Audio frequencies (which may come from a microphone, record player, tape recorder, etc) are first amplified, and then fed into a **modulator**. This is a circuit which changes the level or strength of the carrier wave in direct proportion to the audio signal being fed into it. So the carrier wave is still the same frequency as it was when it left the oscillator; it just varies in level, or **amplitude** from moment to moment.

The end result is an **amplitude modulated** radio frequency current which is fed into the aerial.

Where higher quality radio transmission is required, a different type of modulation is used. This is **FREQUENCY MODULATION**, or "**FM**". Here the audio frequency signal is used to vary not the strength of the RF carrier waves, but their frequency. The strength of the waves remains constant, with only their frequency "**wobbled**" by the audio signal. Because the carrier waves remain at full strength all the time, even during the quiet passages, they are always much stronger than atmospheric noise or "static" – so FM transmission tends to give much quieter and clearer reception than AM.

## types of transmitters

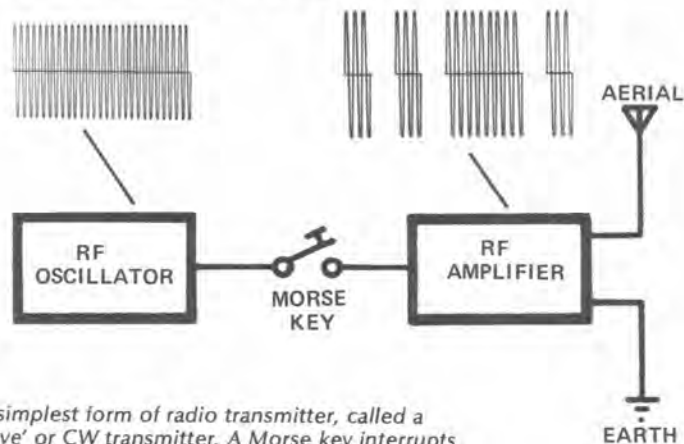

Figure 5: The simplest form of radio transmitter, called a 'continuous wave' or CW transmitter. A Morse key interrupts the continuous wave to give it some form of intelligence.

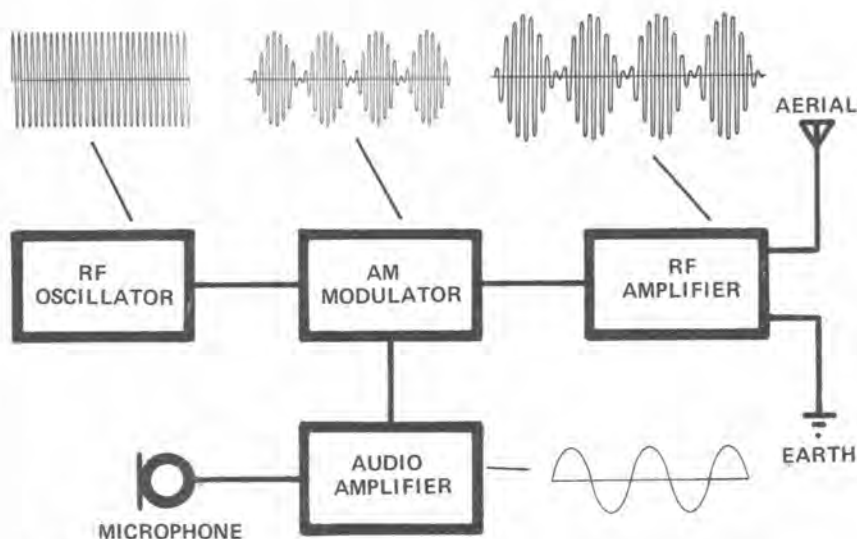

Figure 6: An amplitude modulated (or 'AM') transmitter. The amplitude, or strength, of the wave is varied in accordance with the audio input. The frequency remains constant, however.

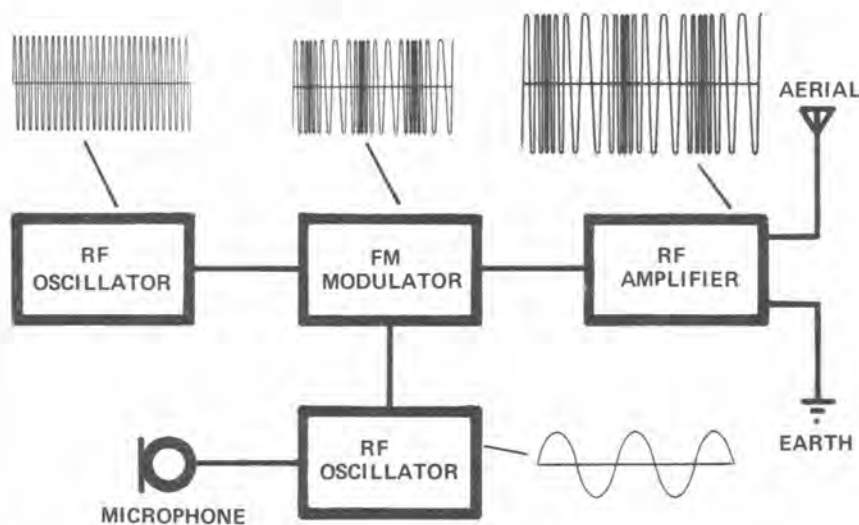

Figure 7: A basic frequency modulated, (or 'FM') transmitter. In this case, the amplitude of the wave remains constant; the frequency is varied up and down over a small range according to the audio input. This type of signal is much less prone to degradation by noise.

# at the receiving end . . .

As you will imagine, there are a lot of signals picked up by the aerial. Hundreds of radio stations, TV, stations, hams and Cbers, business two-way radio, etc etc. Yet we only want to listen to one station at any particular time. It is up to the receiver to filter out the station we want from all the incoming radio frequency signals.

The tuning circuit does this for us. It is a very selective filter which discards all the RF currents bar one: the one we have selected by the tuning capacitor.

From the tuning circuit, there are very different circuits for AM and FM signals. We'll look at the simplest circuit first, that of an AM detector.

The single RF current, still amplitude modulated and bearing the information we want to extract, is passed through a diode. As we explained in our projects, a diode only lets current pass in one direction. So the diode lets the top half of the signal through, but blocks the bottom half.

Why block half? An earphone or speaker would see the double-sided waveform as mirror-image. It would simply add the positive and negative halves together and we would end up with nothing!

The half cycle contains all the signal information, as well as the RF 'carrier'. All we want now is the signal information; the carrier has done its job, and we can now discard it. A capacitor can do this: a value is

chosen that is too small to affect audio frequencies, but passes radio frequencies with ease.

All that remains is the original audio signal; a replica of the one which was fed into the modulator at the transmitter. This signal can drive an earphone direct, or be amplified to drive a loudspeaker.

This description is for a 'crystal set' type of receiver, the simplest receiver possible (see 'Fun Way 1'). Most receivers, however, have extra stages in them for further signal processing.

For example, the 'superheterodyne' (see Circuit Milestones) changes the frequency of the incoming signals before detecting them. They are easier to control doing this, giving a number of advantages. Most transistor radios today are superheterodyne types.

Even in a 'superhet' circuit, the basic diode detector is usually used, in much the same way as above.

## Receiving FM

While it is possible to detect FM signals with fairly simple circuits (a technique called 'slope detection' is one of these), to take full advantage of FM's potential, quite complex circuitry is required in the receiver.

Most FM receivers use a special detector called a 'discriminator', which basically compares the incoming frequency modulated signal against a reference signal: the difference between the two is the original audio signal.

The situation is further complicated by the fact that most FM transmission is in stereo, so the receiver also has to separate the stereo signal pairs from the single transmitted wave.

The output from the discriminator is virtually the same as the output from an AM detector (though there would be two outputs in the case of a stereo receiver). It is then ready for amplification in a conventional audio amplifier.

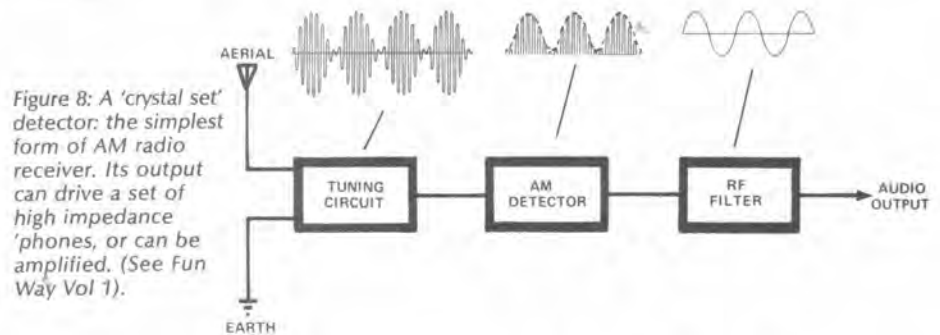

Figure 8: A 'crystal set' detector: the simplest form of AM radio receiver. Its output can drive a set of high impedance 'phones, or can be amplified. (See Fun Way Vol 1).

Figure 9: A 'superheterodyne' radio receiver (see also page 35). The incoming signal is mixed with another signal generated in the receiver. This produces an 'intermediate frequency' which is much easier to handle than the original RF signal.

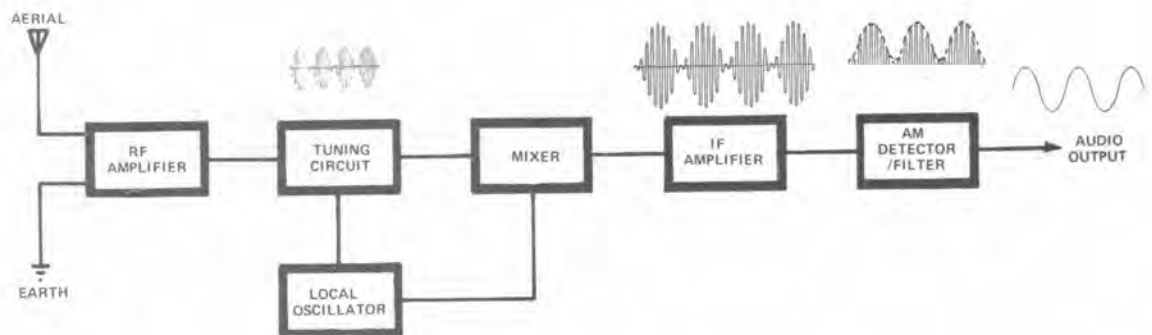
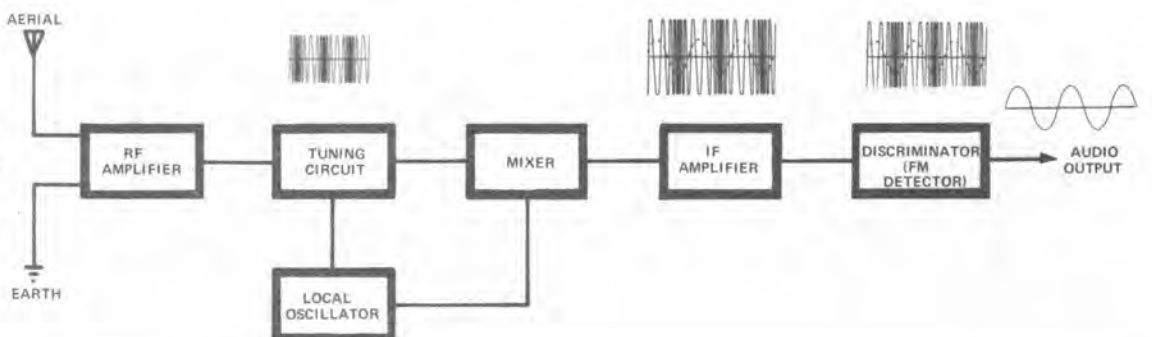

Figure 10: A receiver capable of detecting FM. The dotted line in the waveform shows the signal we are trying to extract. This could actually be two signals if the FM broadcast is in stereo.



# how to make your own PC boards

## What is a Printed Circuit Board?

Basically a PCB is a sheet of insulating material with a thin layer of copper laminated to the surface. The copper is etched away, where not required, to form the conductors of the circuit. The various components required in the circuit are usually mounted on the board on the opposite side to the copper, with their leads passing through small holes and soldered to the copper. Printed Circuit Boards are a far more efficient, reliable and compact method of connecting components together than previous methods of wiring.

The PCB's supplied in the kits that constitute the projects in this book, have been prepared professionally, but there is nothing to stop you preparing your own boards, either from the layout patterns in this book or from scratch using your own designs.

The un-etched board is as shown in figure 1, with a thin layer of copper attached to a sheet of insulating material, which may be of SRBP (synthetic resin-bonded paper) or fibreglass. More complex electronic circuits may require double-sided boards which, as the name suggests, have the copper on both sides of the insulating material. They may even have 'plated through holes', connecting the two copper sides together at various points.

A typical etched board is shown in figure 2, where the unwanted copper has been etched away by acid to leave the required circuit pattern.

PCB's vary considerably in both thickness of the insulating material and of the copper but the more common are around 1.5mm thick with 0.03mm - 0.07mm of copper.



Figure 1



Figure 2

## Cutting the un-etched board to size.

If you do not have a blank board of the required size you will need to cut a piece from a larger sheet. This may be done with a fret, coping or similar fine bladed saw, figure 3, or by scribing the board deeply along its dimensions on both sides and snapping off the required piece. The edge of a small screwdriver or the broken edge of a hacksaw blade make good scribes.

Using the edge of a steel rule as a guide, figure 4, scribe deep lines on both sides of the board directly opposite each other until the board is able to be snapped off cleanly. Dress the edges by filing to remove all burrs and roughness.



Figure 3



Figure 4

## How to form conducting paths.

As we have said the un-etched board has copper completely covering the surface of the insulating base material, figure 1. To make the required 'tracks' and 'pads' the excess copper must be removed, leaving a pattern similar to the one shown in figure 2. This is done by coating the areas that are to remain with an acid resisting compound or material called a 'resist'. After this 'resist' is applied, the whole board is immersed in an acid solution known as an 'etchant', which will etch away any copper not covered by the 'resist' leaving only the required tracks and pads.

## The PCB layout

Before the resist material can be applied to the board, a suitable layout must be worked out to join the circuit components together. This may mean using an existing PCB pattern, such as one of those provided in this book, or designing your own. Various methods are used but here is a simple method to start you off.

Using your circuit diagram as a reference (see figure 5) layout the components to give the easiest and simplest joining of the conduction tracks. You will find that using 0.1" or metric graph paper as a layout guide will be a great aid as a left/right, up/down reference as well as providing stable reference for marks for component mounting holes etc. It is important to remember that your components will be on one side of the board while your tracks will be on the other (copper) side.

This layout stage is a matter of trial and error, but after a little practice it will become easier and you will find the results very rewarding.



Figure 5

Because this process is similar to printing photographs the circuits resulting are called 'printed circuits'.

When more than one board with the same circuit is required they may be produced photographically or by silk screening. This is the commercial method of production and is mentioned only as a matter of interest.

After the track layout has been done you can put in size reference marks to enable you to cut the finished board to the exact size you require. These marks are represented in figure 5 by the four crosses, one in each corner of

# making printed circuit boards . . .

the board layout. It is only necessary now to mark on the tracks the positions of the component holes and this is done by making an oversize 'full-stop' on the track at the point where the components will be placed.

## Cleaning the copper surface.

This simple but extremely important step is necessary to remove all dirt, corrosion, grease, etc from the surface of the copper so that the resist material will 'take' properly. One method is to apply a spirit such as metho, freon, alcohol, acetone or trichlorethylene to a clean rag and rub it briskly over the surface.

Another quite satisfactory method is to use a common household cleaning powder such as 'Ajax' applied with a clean rag soaked in warm water. As the powder acts as an abrasive it is advisable to rub in one direction only so that the fine scratches line up, giving the surface a brushed look. (See figure 6)

Once cleaning is complete flush the surface under a fast flowing warm water tap and immediately dry with a clean cloth.

**IMPORTANT:** From now on do not touch the surface of the board with your fingers or any dirty or greasy objects. Handle it by the edges as you would a record.



Figure 6

## Preparing the board for the application of the resist material.

You are now ready to transfer your circuit layout to the copper in readiness for applying the resist material. As shown in figure 7 place a piece of carbon paper, carbon downwards, on to the copper foil so that it completely covers it. Place your

prepared artwork over this so that the dimension marks line up exactly with the edges of the board. Fold the edges of the paper around the board and tape firmly in place with adhesive tape. Figure 8 shows the artwork being laid over the carbon paper prior to its being held down with adhesive tape.



Figure 7



Figure 8

Now, with a pen or pencil, trace all the tracks and pads on the artwork. This will transfer the pattern via the carbon paper to the copper surface.

Remove your artwork (don't destroy it, you may need it) and carbon paper and the board is ready for the application of the resist material.

## Application of resist material or compound.

Resist materials may take many forms but we will limit our discussion here to the three you are most likely to use: bituminous paint, Dalo pen and PC Board transfers.

### Bituminous Paint

This may be applied with a number of brushes or pens, whichever you find easiest to use. As it is normally thick, you will need to thin it with small amounts of kerosene or mineral turpentine to a consistency where it will flow freely and evenly with the

pen used. It may also be thinned by warming the container in a pan of hot water as shown in figure 9. This method will reduce the drying time of the applied solution

Apply the paint evenly and smoothly, preferably after a few practice runs on a piece of scrap board and when you have followed all of the traced marks, allow about 1/2 an hour to dry.



Figure 9

### Dalo Pen

As you can see from figure 10, the Dalo Pen is very similar to a normal felt tipped pen. It is a very convenient method of applying the resist solution, as you can virtually draw the circuit pattern on the copper foil. If the resist solution does not flow on smoothly, it indicates the surface is not clean.

To increase the flow of resist, push down on the tip to pump out more fluid. Allow 15 minutes to dry.



Figure 10

### PC Board Transfers

These are pressure sensitive, rub-on transfers applied to the surface of the copper foil with a smooth, round pointed instrument such as a thick ball point pen, knitting needle, or the end of a paint brush handle.

Take care that the transfer does not crack or peel as it is applied, as this will allow the etchant to penetrate. If cracking does occur, lightly scrape the transfer off and start again.

... continued

## Etching Materials

Various types of etchants are used commercially, including ferric chloride, ammonium persulphate, nitric acid etc. We will only discuss ferric chloride as it is the safest and most readily available. Nitric acid is not recommended as it is highly corrosive, difficult to store and very dangerous to handle.

### Ferric Chloride

This may be obtained either as an anhydrous (dry) powder or a concentrated liquid. Both must be diluted by water to the required strength.

**IMPORTANT:** Follow the label instructions carefully when diluting either the solution or the powder. Add the powder to the water slowly, stirring as you do so. You will notice that heat is generated as the two come together. Approximate quantity mixing ratios are 500 grams of powder to each one litre of water.

## Etching the Board

The etchant is poured carefully into a flat container of glass, porcelain or plastic, large enough to hold the board to be treated. Slip the board into the solution (see figure 11) and agitate from time to time, but be careful not to breath the fumes. After all traces of unwanted copper have gone, remove the board and wash it under a running tap before drying it off with a clean rag. Etching time will vary, depending on etchant strength, size of the board, amount of copper to be removed, temperature etc., 10 to 30 minutes is common. Etching time may be reduced by agitating the etchant and heating the solution. (DO NOT BOIL). The solution may be used again, but it will become slower in action as successive boards are etched.



Figure 11

**IMPORTANT:** Etchants are corrosive and should be handled with care, with any spillage being cleaned up immediately. Used or waste etchant should be disposed of sensibly.

## Drilling the Board

Once the board has been etched, washed and dried, you are ready to drill the holes. The drill point for the holes can be made with a centre punch. Place the centre punch so that the sharp point is in the position where the hole is to be drilled, and tap the head of the punch very lightly so that the indent made is just sufficient to penetrate the copper foil. An automatic centre punch with adjustable impact is ideal for this purpose (see figure 12).

Although the hole size requirements may vary because of component lead thickness, only a few drill sizes are generally required. The most common sizes are: No. 65 (0.83mm) for semiconductor devices e.g. IC's and transistors and No. 59 (1.0mm) for general components such as resistors and capacitors.

If you don't intend making a lot of PC Boards a pin vice may be used to hold the drill. The pin vice is also very handy for enlarging or cleaning holes. (Vices Cat. T-5110 or T-5115 are ideal.) For larger boards, or if you intend to make more boards the battery operated Minidrill (Cat. T-4750), the Reliant Handrill (Cat. T-4740), or the Titan Handrill (Cat. T-4730) are all hand held high speed units ideally suited to this job.

Drill carefully, keeping the drill upright at 90° to the board to make clean, straight holes. (See figure 13).



Figure 12



Figure 13

**CAUTION:** It is not advisable to use the normal hand held electric drill as they are too clumsy and broken drills may result. But if you have access to a high speed vertical drill press, this would be very suitable.

## Final Cleaning

As in the original cleaning of the board, a household cleaning powder is suitable for this task. Rub only in one direction until all traces of resist and dirt have been removed (see figure 14) and then flush the board under a tap before drying with a clean cloth.

**DON'T TOUCH THE COPPER SURFACE UNTIL IT HAS BEEN PROTECTED.**



Figure 14

## Surface Protection

To protect the copper surface against tarnishing during handling, a protective lacquer is sprayed lightly to form a thin film over the printed foil. (See figure 15). A suitable spray is PCL-2 circuit lacquer (Cat. N-1045). This spray is solder through, which means that it will not hinder soldering on to the board.

Your printed circuit board is now complete and can be used immediately or stored for later use without deterioration.



Figure 15



# Technical terms . . .

<b>Aerial (antenna)</b>	These terms are often used to mean the same thing. For our purposes, an aerial is a length of wire which is designed to receive or transmit radio waves.	<b>Conductor</b>	An object which will allow electricity to flow through it relatively easily. Most metals are conductors; most non-metals are not. Some conductors are better than others.
<b>AC</b>	Stands for alternating current. Current which goes through a number of 'cycles' of reversal each second.	<b>Connection</b>	Where two (or more) component leads or hook-up wires actually and deliberately touch, so that current can flow between them. If a connection occurs where it is not wanted it is sometimes called a 'short circuit' (or 'short').
<b>AF</b>	Stands for Audio Frequency. It is generally accepted that audio frequencies occupy the part of the spectrum below 20kHz. Most humans can hear down to about 30Hz and up to about 15kHz but some animals, notably dogs and cats can hear higher than this. (See <i>Dog and Cat Communicator Project in Fun Way Vol. I</i> ).	<b>Crossover</b>	Where two component leads or hook-up wires intersect, but no connection occurs because they are insulated from one another.
<b>AM</b>	Stands for Amplitude Modulation. One of the types of radio transmission (the type used by most broadcasting stations) where audio frequency signals vary the strength of a radio frequency 'carrier wave'. This is called 'modulation'. See 'Understanding Radio'.	<b>Current</b>	A movement of electrons along a wire or other conductor. By convention, current flows from the positive terminal, through the circuit and back to the negative terminal of the battery.
<b>Amplify</b>	To enlarge. A circuit that amplifies is one that takes the original signal and <b>adds energy to it</b> without substantially changing the nature of the signal. Changing the nature of the signal is called 'distortion'.	<b>Dark State</b>	When referring to a light sensitive device such as an LDR, the dark state refers to the behaviour or operating conditions when no light is falling on it. The converse is the device's 'light state'.
<b>Audio Transformer</b>	A device which transfers audio signals from one section of a circuit to another, while blocking DC. See 'Components' section.	<b>DC</b>	Stands for Direct Current – current which does not change in direction.
<b>Base</b>	One of the connecting leads of a transistor. See 'Components' section.	<b>Distortion</b>	See 'Amplify'.
<b>Battery</b>	A device for supplying electric power. See 'Components' section.	<b>Earth (Ground)</b>	Normally taken to mean the same thing. Can mean a direct connection to the earth itself, but is also used to mean a connection to a chassis or point of zero voltage.
<b>Bipolar</b>	A type of transistor, historically the first type invented. Bipolar literally means 'having two poles'. In a bipolar transistor the current through the emitter flows to or from (depending on type) two terminals – or poles – the base and the collector. See 'Transistor' in the 'Components' section.	<b>Earphone</b>	A device for turning electrical energy into sound waves. Called an earphone because it fits in or on your ear. See 'Components' section.
<b>Broadcast Band</b>	The section of the radio frequency spectrum covering 'medium wave' radio stations – normally 530 to 1600kHz.	<b>Electric Current</b>	See 'Current'.
<b>Capacitance</b>	Having the properties of a capacitor. See 'Components' section.	<b>Electrolytic</b>	When used in conjunction with capacitors, refers to the type of capacitors made with an 'electrolyte' (See 'Components' section). Electrolytes are chemical liquids or pastes having certain properties, used in various ways in electronics.
<b>Carrier Wave</b>	A radio wave which does not have any signal information of its own, but carries the signal along with it.	<b>Emitter</b>	Another lead of a transistor. See 'Components' section.
<b>Cell</b>	A single battery or chemical power source. The batteries we use in these projects contain various numbers of cells to produce different voltages.	<b>Feedback</b>	Occurs when some or all of the output of a device (an amplifier, for example) can be fed back into the input. Feedback may be accidental and unwanted (as in the case of acoustic feedback from a speaker to a microphone with a resultant squeal) or deliberate (as in many types of circuits where feedback assists in correct operation).
<b>Circuit</b>	The components, connections, wires and hardware that together form a working module. A drawing of the circuit is called a circuit diagram or schematic diagram.	<b>Ferrite Rod Aerial</b>	A coil or coils of wire wound around a rod made of ferrite (a black or grey material). Ferrite concentrates the effects of the coil.
<b>Collector</b>	Another of the leads of a transistor. See 'Components' section.		

**Frequency Response** This is the band of frequencies in which a component will efficiently operate. Frequency response is a term commonly used in relation to HI-FI. A quality loudspeaker system, for example, in a suitable cabinet may claim to have a frequency response from 50Hz to 20,000Hz. To qualify this frequency response you must state several other factors e.g. you must state whether the same amount of sound is radiating from the cabinet at 20,000Hz compared to say 1,000Hz or 50Hz. If one frequency is being reproduced more efficiently (i.e. "louder") than the others it must be specified by **how much** compared to a reference level. You must also state what power is being fed into the system. The "smoother" the frequency response the more likely it is that all frequencies within the band will be reproduced in accordance with the original signal.

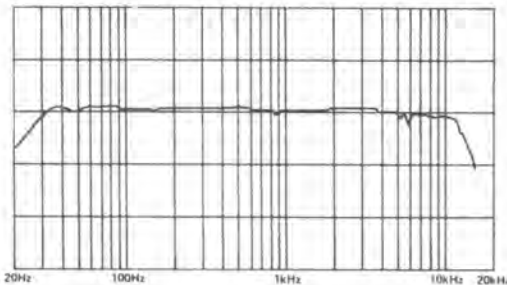

Typical frequency response graph of hi fi speaker system. Note the smooth curve.

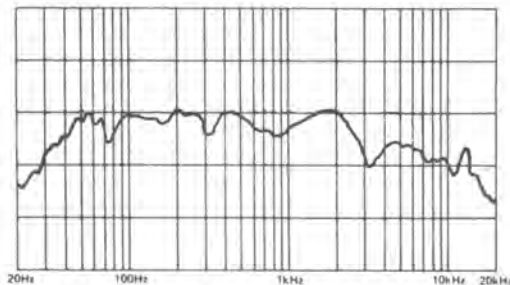

This shows the response of a speaker with peaks and troughs indicating that the sound would not be ideal.

**Frequency** The number of times an AC signal repeats its cycle each second. It is measured in Hertz (Hz). Was formerly called cycles per second. In other words, one Hz equals one cycle per second.

**FM** Stands for Frequency Modulation. It is another way of transmitting signal information on a carrier wave, with several advantages over Amplitude Modulation. See 'Understanding Radio'.

**FM Band** The section of the radio frequency spectrum covering radio stations which use 'Frequency Modulated' transmission. In Australia this band is 88 to 108MHz.

**Gate** A digital electronic circuit whose output state (high or low) depends on the state(s) at the input. There are three basic types of gates: 'AND' gates, where all inputs must be high before the output goes high (if any input goes low the output also goes low); 'OR' gates, where any input going high will also make the output go high; and 'NOT' gates, which simply invert the input state – if the input goes high, the output goes low, and vice versa.

**Generator** A device for mechanically or electronically producing electric current. Normally refers to a machine producing DC – but can also be used in other contexts.

**Germanium** A rare metalloid chemical element, from which germanium small signal diodes and certain transistors are made.

**Greencap** A colloquial name given to a type of polyester capacitor. See 'components' section.

**HI-FI** Stands for High Fidelity. Fidelity means faithful or accurate in detail. High fidelity is commonly applied to give a broad impression of the performance of music and sound reproduction equipment. Unfortunately the term is used far too loosely and it suffers in the interpretation. What one person regards as HI-FI, another doesn't!

**Hertz** See frequency.

**Impedance** The total opposition (resistance) a circuit (or component in the circuit) offers to the flow of alternating current at a given frequency. If the frequency of the AC changes the impedance changes, up or down. Impedance is measured in ohms. A resistor on the other hand does **not change** its ohmic value when the frequency changes.

**Input** The side of the circuit to which a signal is fed for processing. (Converse: output).

**Insulator** A material which will not allow electricity to flow through it. (Converse: conductor). Most wire is covered with a plastic insulator to prevent the wires shorting to any other conductors.

**Integrated Circuit** A tiny piece of semiconductor material containing up to thousands of transistors, diodes, resistors, and other components. See 'components' section.

**Leaking** (a) electrolyte escaping from a battery, capacitor, etc. Often very corrosive. (b) the action whereby a charge stored in a capacitor or battery slowly diminishes. Occurs because no components can be made 100% perfect.

**LED** Short for Light Emitting Diode. See 'components' section.

**LDR** Short for Light Dependent Resistor. See 'components' section.

**Loudspeaker** Another device for converting electric currents into sound waves. See 'components' section.

**Matching Transformer** See audio transformer.

# technical terms . . . continued

<b>Microphone</b>	A device for converting sound waves into electric currents. <b>See 'components' section.</b>	<b>Semiconductor</b>	(a) Neither a conductor nor an insulator, but somewhere in between. Often with the properties of being able to change by various means. (b) the name given to a whole family of devices using semiconductors for their operation: transistors, diodes, integrated circuits, etc. <b>See 'components' section.</b>
<b>Modulation</b>	<b>See AM and FM</b>	<b>'Small Signal'</b>	A device which is not meant to handle large currents. Such devices are easily damaged if overloaded.
<b>Monitor</b>	To continually examine. We use LEDs to continually examine parts of the circuits – they glow if current flows.	<b>Spaghetti</b>	A form of insulation. <b>See 'components' section.</b>
<b>Morse Code</b>	A system of communication invented by Dr Samuel Morse many years ago. It relies on the sending of only two sounds – a short one and a long one. All letters and numerals are represented by combinations of these sounds. ( <b>See project 3</b> ).	<b>Switch</b>	A device for connecting and disconnecting power or other components to a circuit or parts of a circuit. <b>See 'components' section.</b>
<b>Multivibrator</b>	A popular circuit in electronics where two transistors are made to alternately turn on and off.	<b>Time Constant</b>	In our circuits, a measure of the time it takes for a capacitor to charge (or discharge), with a certain resistor.
<b>NPN</b>	One of the types of transistor we use in this book (converse: PNP). <b>See 'components' section.</b>	<b>Timer</b>	Any circuit or device capable of causing an action after a given time delay. Most of our timer circuits use a special integrated circuit designed to do this, with just two external components to pre-set the time delayed required.
<b>Oscillator</b>	A circuit which produces alternating current. Can be at any frequency but normally used in relation to audio or radio frequencies.	<b>Tolerance</b>	All components are made so they are within a certain percentage of their marked value – this is the tolerance. For example, a resistor marked 1k, 5% might in fact have a value anywhere from 950 ohms to 1050 ohms.
<b>Output</b>	That part of the circuit where the processed signal is available for use. (Converse: input).	<b>Transistor</b>	A semiconductor amplifying or switching device. <b>See 'components' section.</b>
<b>PNP</b>	Another type of transistor we use. (Converse NPN). <b>See 'components' section.</b>	<b>Transmitter</b>	A device for emitting radio waves. These may be bursts of carrier wave (such as a Morse transmitter) or they may be modulated by audio frequencies (as in a voice transmitter).
<b>Polarised</b>	A component, plug, etc, which must be inserted or connected a certain way for the circuit to operate. If reverse connected, damage may occur.	<b>Tuning Dial</b>	A dial connected to a variable capacitor, often marked so the stations can be easily found. <b>See 'components' section.</b>
<b>Polarity</b>	The specific way a polarised component must be connected to the circuit for correct operation (see "Polarised" above).	<b>Unijunction</b>	<b>See 'components' section.</b>
<b>Polyester</b>	A type of capacitor. <b>See 'components' section.</b>	<b>Variable Capacitor</b>	A type of capacitor constructed so that it can be varied by moving a rotating shaft. Usually used with some form of tuning dial. <b>See 'components' section.</b>
<b>Power</b>	Normally taken to mean the source of energy which makes a circuit work (e.g. when power is applied). Electric power in our case.	<b>Volume</b>	The level of sound which comes from a loudspeaker or earphone. A volume control is usually a potentiometer, and is situated at the input to the main amplifying section of the circuit.
<b>Primary</b>	(a) the 'input' side of a transformer. (b) a non-rechargeable battery, such as a torch battery.		
<b>Probe</b>	Usually connected to test equipment to enable connection to various parts of the circuit under test.		
<b>Radio Frequency</b>	RF for short. The part of the spectrum with frequencies from around 20kHz and above.		
<b>Relay</b>	An electro-mechanical device which switches a set or sets of contacts when sufficient current is passed through its coil. The coil becomes an electro-magnet, pulling in a plunger which moves the switch contacts. ( <b>See components section and 'using relays'</b> ).		
<b>Schematic</b>	Another name for circuit diagram.		
<b>Secondary</b>	(a) the 'output' side of a transformer. (b) A re-chargeable battery, such as a car battery. You can feed electric current back into the battery and charge it. You must not do this with a torch battery.		
<b>Short</b>	Short circuit. <b>See 'connection'.</b>		

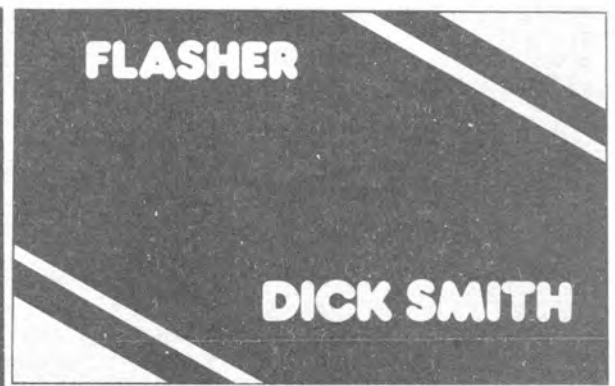
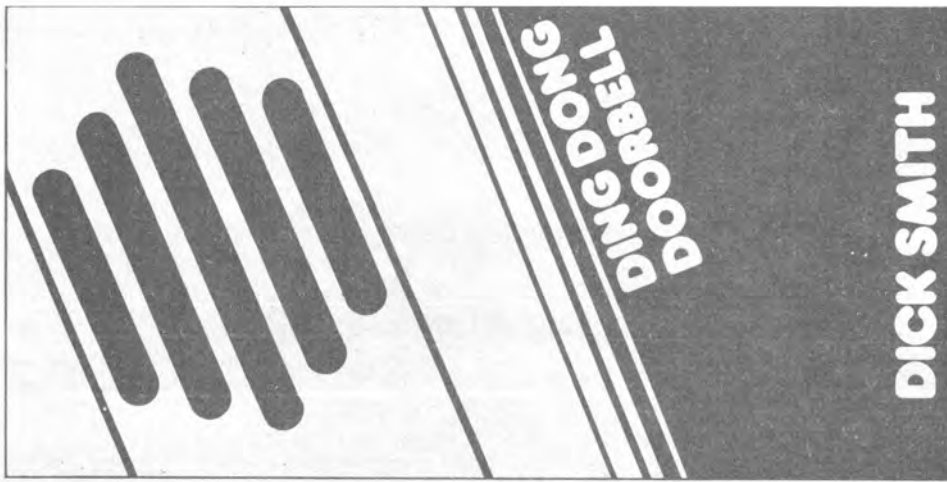

**DICK SMITH**

**MORSE CODE TRAINER**

A	di'dah	O	dah dah dah
B	dah di'di'dit	P	di'dah dah dit
C	dah di'dah dit	Q	dah dah di'dah
D	dah di'dit	R	di'dah dit
E	dit	S	di'di'dit
F	di'di'dah dit	T	dah
G	dah dah dit	U	di'di'dah
H	di'di'di'dit	V	di'di'di'dah
I	di'dit	W	di dah dah
J	di'dah dah dah	X	dah di'di'dah
K	dah di'dah	Y	dah di'dah dah
L	di'dah di'dit	Z	dah dah di'dit
M	dah dah	.	di'dah di'dah di'dah
N	dah dit	?	di'di'dah dah di'dit

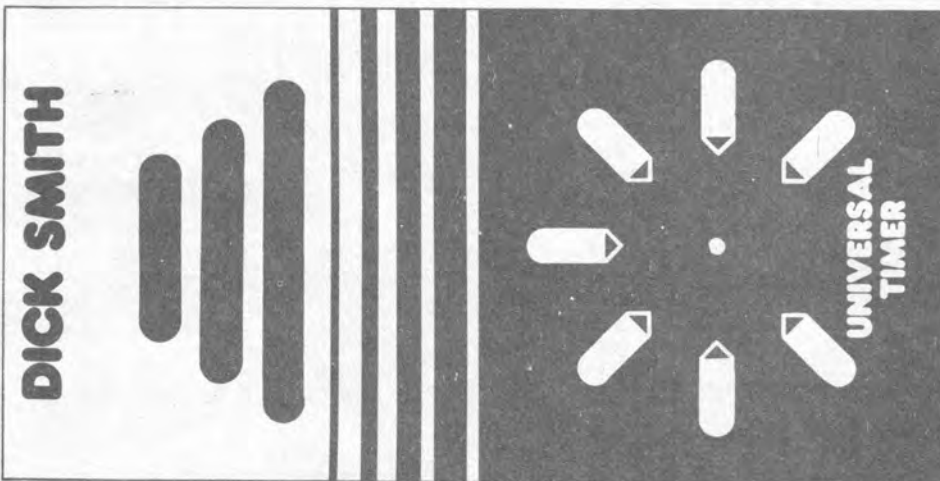

Cut out these labels with a pair of scissors. They can be glued to the aluminium panels with rubber solution, or many other liquid glues.

Over the next six pages, you will find cut-out labels for your projects and templates for drilling the holes. There are no labels for the touch switch (the touch pad cannot have any covering); but two labels are supplied for the intercom — one each for the master and slave.

On the reverse of the labels are printed drilling templates for each project (once again, no template for the touch switch, nor the organ — the pcb is the panel). Instructions for use of the templates are printed overleaf. Don't cut out your labels before reading the template instructions!

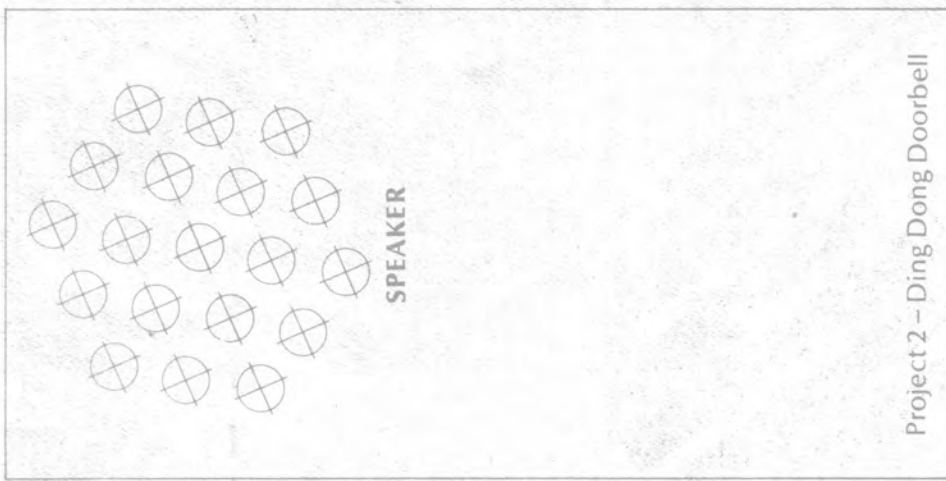

Project 2 - Ding Dong Doorbell

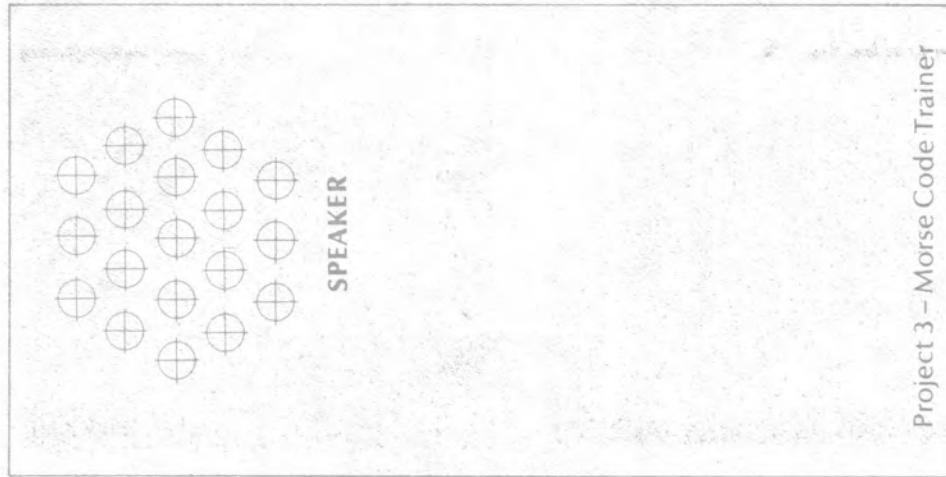

Project 3 - Morse Code Trainer

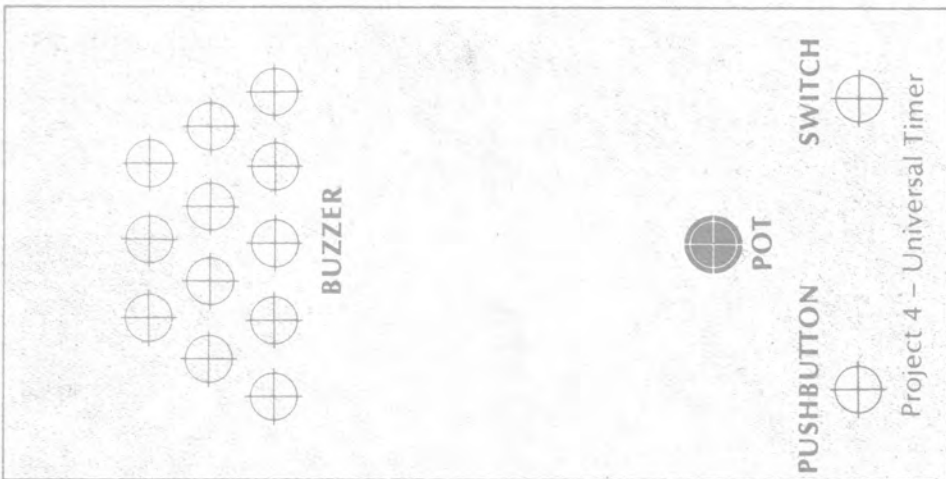

Project 4 - Universal Timer

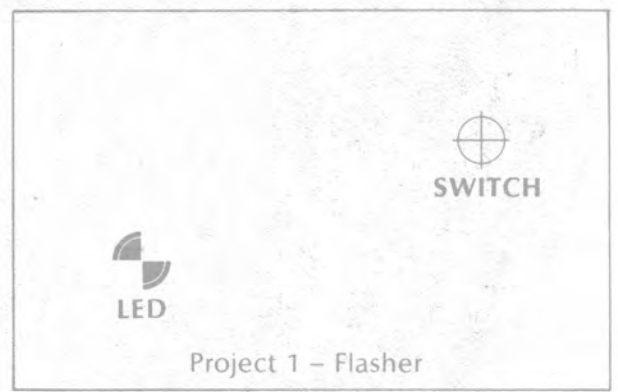

Project 1 - Flasher

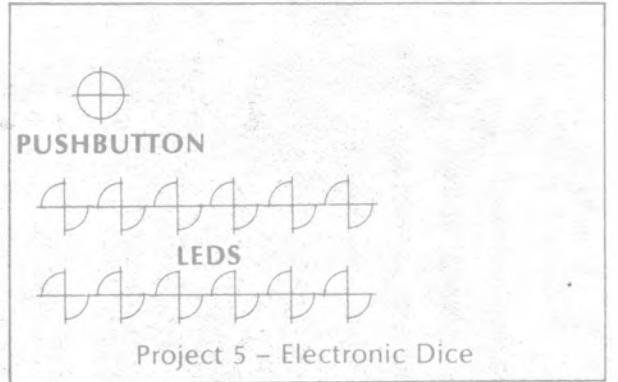

Project 5 - Electronic Dice

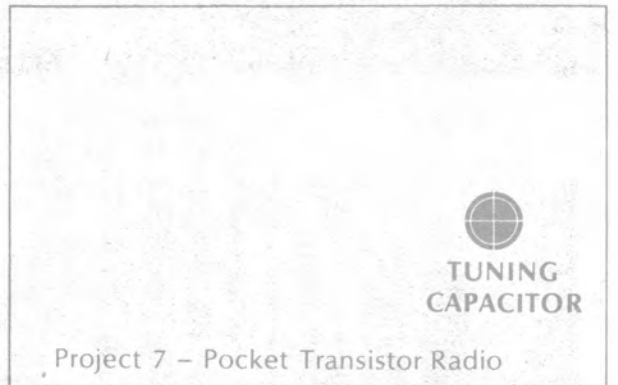

Project 7 - Pocket Transistor Radio



Project 11 - Wireless Microphone

These templates are printed in green to avoid any 'show through' onto the labels on the other side of the paper. These templates can be used two ways: either photo-copy them and use the copies to drill direct, or very lightly trace over them with a sheet of carbon paper on the other side of the page with your panel underneath. Don't press too hard or you will mark the panels.

These templates are NOT in the same positions as the labels on the other side of the sheet: so don't cut the templates or labels out and expect them to be 'back-to-back': they won't be!

**KEY TO DRILLING TEMPLATES**



**DICK SMITH**

**MOSQUITO REPELLER**

**DICK SMITH  
AMPLIFIER**

**DICK SMITH**

**LIGHT  
ACTIVATED SWITCH**

**METAL LOCATOR**

**DICK  
SMITH**

**SOUND ACTIVATED SWITCH**

**DICK  
SMITH**

**DICK  
SMITH**

**ALARM**



**SPEAKER**



**SWITCH**

Project 9 – Mosquito Repeller



**SWITCH**



**INPUT  
SOCKET**



**SPEAKER**

Project 10 – Amplifier



**SWITCH**



**SOCKET**

Project 12 – Light Activated Switch



**SWITCH**



**POT**



**EARPHONE  
SOCKET**

Project 13 – Metal/Pipe Locator



**MICROPHONE**



**SWITCH**



**SWITCH**

Project 14 – Sound Activated Switch



**LED**

Project 15 – Home/Car Alarm

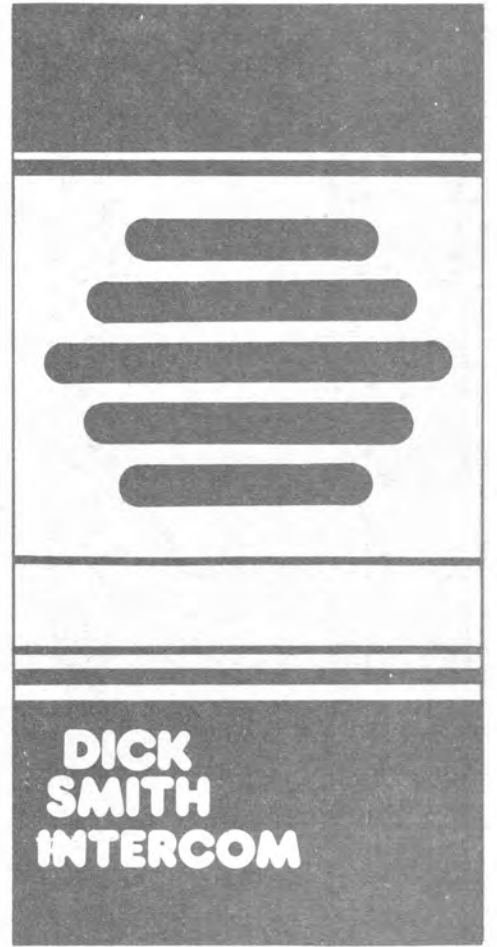
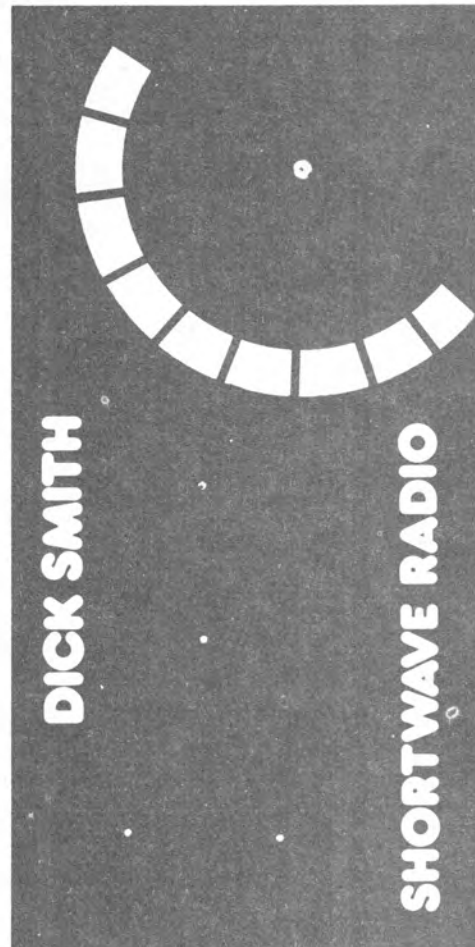
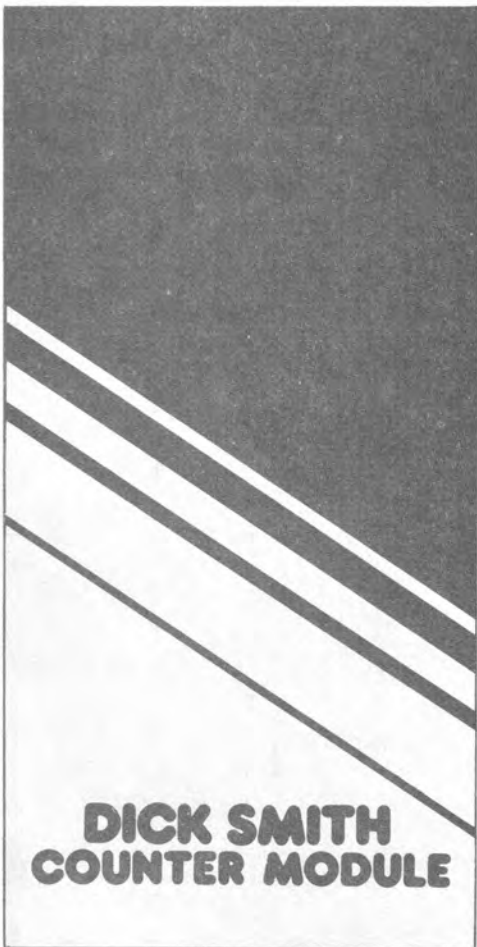
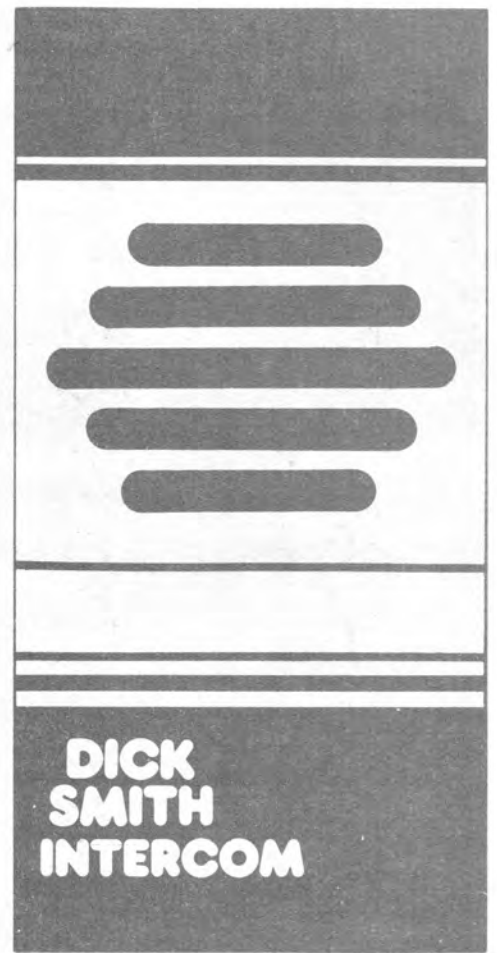
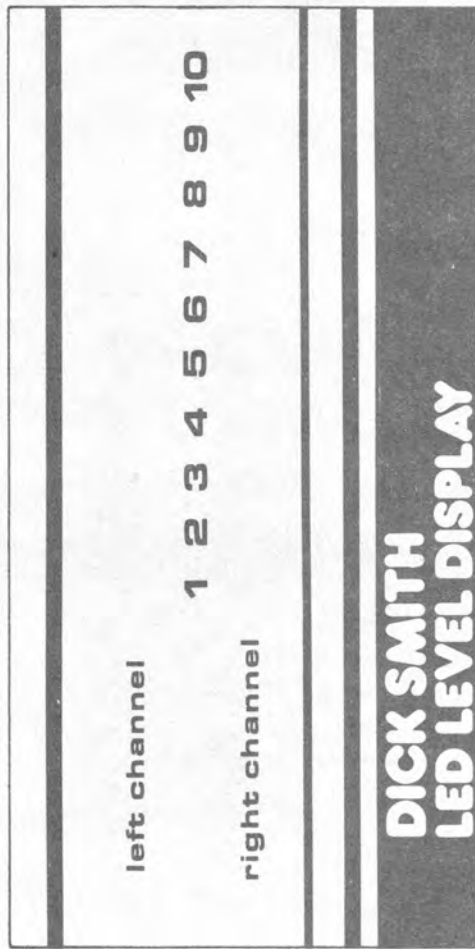





Project 16 – Electronic Siren

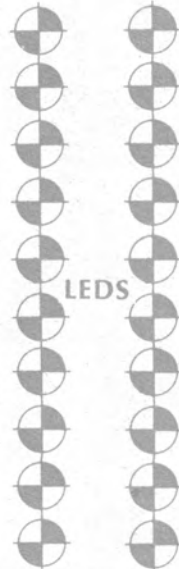

Project 17 – LED Level Display

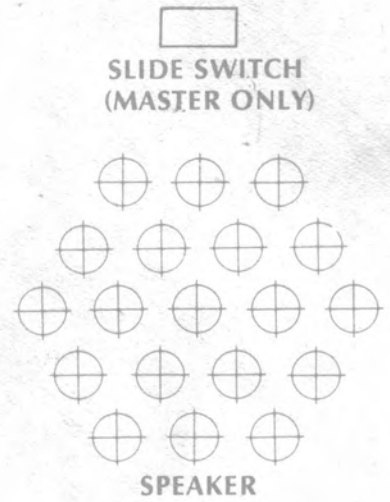

Project 18 – Intercom

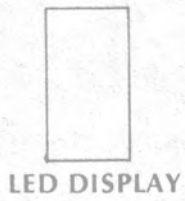

Project 19 – LED Counter Module



Project 20 – Shortwave Receiver

**LOW PRICES  
- YOU REAP  
THE BENEFIT!**

# A great range of Tools and Accessories for the Kit Enthusiast

**A range of directly  
imported stainless steel  
pliers of a quality we've  
sought for years!**

## Soldering Accessories

### Solder Sucker

A rugged, all metal construction solder sucker complete with Teflon tip and a nozzle sweeper as well. Light thumb release mechanism for the removal of solder from the board. Don't pay twice the price - a top quality import from Dick Smith.

Cat. T-2560 **\$13<sup>50</sup>** ~~\$7<sup>95</sup>~~  
Spare Teflon tip to suit ...  
Cat. T-2565 ... \$2.00

### Solder

A liberal amount of solder in a hobby pack.

1.25mm (18g) hobby pack. Approx. 4m **\$1<sup>30</sup>**  
Cat. N-1638  
0.71 (22g) hobby pack. Approx. 9m **\$1<sup>30</sup>**  
Cat. N-1636

## 20 Piece Metric Utility Set

This set has to be seen to be believed. 20 piece nickel chrome molybdenum steel with chrome plated handle presented in a handy transparent plastic box. The set includes:

3 x blade screwdrivers: 1.5, 2.5, 3.5mm. 2 x Philips screwdrivers: No. 1 and No. 0. 3 x hex Allen keys: 1.5, 2.0, 2.5mm. 5 x open end spanners: 4, 4.5, 5.0, 6.0mm. 5 x spiritlights: 3.0, 3.5, 4.0, 4.5, 5.0mm. tommy bar, 1 awl, 1 handle assembly. You will be proud to have this excellent quality set in your tool range. Great value for money!  
Cat T-4365

## Combination Tool Set

A five piece set consisting of: 1 precision jewellers screwdriver, 1 baby blade screwdriver, 1 x 5/32" nut springtight, 1 x 1/4" nut springtight. A handyman's kit presented in a handsome vinyl case.  
Cat T-4340

## 6 Piece Jewellers Set

**\$4<sup>50</sup>**

Cat. T-4350

These are beautifully made screwdrivers, chrome plated body with a free running knob on the top. The blades are the finest quality nickel chrome molybdenum steel, precision ground. They are presented in a handy transparent moulded case. Sizes range from 0.8mm to 3.8mm.

## DICK SMITH PVC TAPE

Top quality PVC tape. 18 metres long x 19mm wide x 0.2mm thick. Hundreds of uses.  
Cat. N-1362



**\$1.00**

## Needle File Set



This handy set of files has five different types, all 185mm in length. The types are round, square, halfmoon, triangular & rectangular.  
Cat T-4960

**\$12<sup>50</sup>**



**\$10<sup>95</sup>**



**\$4<sup>50</sup>**

## 6 Piece Precision Set

**\$5<sup>50</sup>**

Cat. T-4360

These chrome plated screwdrivers are presented in a plastic storage case. A free running top on each driver gives operator ease of use. The set consists of 4 blade drivers from 1.4mm to 2.9mm and 2 Philips screwdrivers, No. 0 and No. 1. These are quality screwdrivers at a low price and a very handy set to have around.

value

Introducing our brand new range of stainless steel tools - without the normal stainless steel price tag! Every professional, every hobbyist needs the best tools to get the best job. But they used to cost a fortune - until Dick Smith's stainless steel tools came on the scene. Amazing value - they'll last far longer than other tools, are ultra precision made and resist corrosion!

Carefully chosen types for practical applications:

### S/S Transistor Nipper

Ideal for Printed Circuit Board work. Very sharp with a long life cutting edge. Great for trimming of those big jobs on Printed circuit boards.

Cat. T-3205

**\$8<sup>95</sup>**

### S/S Mini Flat Nose Pliers

Great for work on printed circuit boards. Use it as a heat sink while soldering - the wide nose draws away a lot of heat.

Cat T-3325

**\$8<sup>95</sup>**

### S/S Mini Needle Nose Plier

Ideal for work with small components like DS549's etc. Get into those small spaces where bigger tools don't fit.

Cat. T-3570

**\$8<sup>95</sup>**

### S/S Mini Long Nose Plier

Great for getting into those tight spots for pulling out components. Work with these pliers in 'Birdnests' etc.

Cat. T-3565

**\$8<sup>95</sup>**



## Nibbling Tool **\$16<sup>50</sup>**

A unit that can cut any shape opening in sheet steel to 0.6mm thick or light alloy to 1.5mm. Ideal for plastics too. Easy to use, gives good clean cut without distortion. Follows curved or straight lines with ease. Put one in your tool box today!  
Cat T-4940

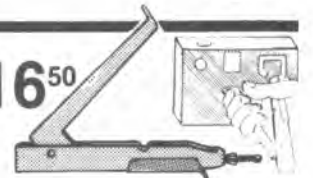

**\$22<sup>50</sup>**

## Hole Punch Set

Ideal chassis basher tool, in fact a necessary tool for anyone who needs a large hole cut through metal. It's easy to use, needs no filing and it will cut a hole without distortion. The complete set includes a 12mm tapered reamer, tommy bar, 5 punches - 16mm, 18mm, 20mm, 25mm, and 30mm. Individual chassis punches bought separately would cost a lot more than the price being charged for the whole set. Will handle steel to 22 gauge and aluminium to 16 gauge.  
Cat T-4900



**\$6<sup>50</sup>**

## Tapered Reamer

An ideal tool for enlarging holes in thin metal, plastics, wood etc. Great idea for chassis bashers, hobbyists, servicemen. Made from the highest quality heat treated steel, comes complete with tommy bar. Tapers from 4mm to 22mm.  
Cat T-4920

# FUN WAY 2 KITS

**SCHOOLS, COLLEGES, ETC:  
ASK ABOUT OUR  
INCREDIBLE DISCOUNTS  
FOR BULK ORDERS!**



## ELECTRONIC DICE

This fascinating circuit uses six LED's connected to the output of a 4017 IC which is pulsed by a NE555 timer IC to simulate electronically the roll of a dice. You'll have hours of fun building it and playing it. A simple change to the circuit converts it to a continuous sequential flasher which can be used imaginatively to make an electronic brooch.

Cat. K-2625 ..... \$5.50

## MONOPHONIC ORGAN

Understand the basics of music synthesis by making this simple two octave organ and then teach yourself to play. Printed circuit board has been designed to fit as the lid of a box to make a convenient and fully portable instrument.

Cat. K-2626 ..... \$8.50

## POCKET TRANSISTOR RADIO

Although very simple to build, the performance of this little set is as good as most of the small 'trannies' available in the shops. Building it will help you to learn about radio and give you hours of fun listening, combining it with an amplifier to produce greater volume and designing it to fit into smaller and smaller places.

Cat. K-2627 ..... \$8.50

## TOUCH SWITCH

Using the 7473 IC, this circuit introduces the basics of switching logic and has literally dozens of applications where touch switching, local and remote, is required. Maybe used as touch ON, touch OFF or as ON while touched and OFF while touched. Has industrial applications as well as novelty uses.

Cat. K-2628 ..... \$5.95

## MOSQUITO REPELLER

This ingenious device uses a unijunction transistor circuit designed to produce a frequency of 21 - 23kHz. This is outside of the human audio range but right on the frequency the male mosquito emits. As pregnant female mosquitos, the only ones who bite, are repelled by males they will keep away from your repeller and you.

Great fun to build and use!  
Cat. K-2629 ..... \$5.50

● SAFE ● SIMPLE ● ECONOMICAL ● FUN

Save money with 'Fun Way' kits!

The components used in the Fun Way book are all common, easy-to-get types. But you can save by buying the kits from Dick Smith.

Each kit contains brand new, guaranteed components. You save up to 1/3 on the cost of individual components!

## INTERCOM AMPLIFIER

Although designed for use in the intercom project, this amplifier can be used in many places, from an amplifier for your radio to a public address amplifier or magaphone.

You'll have hours of fun finding new applications in addition to the uses suggested in the FUN WAY INTO ELECTRONICS VOL 2.

Cat. K-2630 ..... \$6.95

## WIRELESS MICROPHONE

Make this one into a tiny package and slip it into your pocket to give you total freedom to move about while speaking or performing. May also be used to listen to baby by placing it near the cot and tuning in your FM radio in another room. Designed to work on the same principle as the well known spy 'bugs'.

Cat. K-2631 ..... \$6.95

## LIGHT ACTIVATED SWITCH

Designed around the light dependent resistor, this device has many uses to make your life easier and safer.

Use it to switch-in an alarm when it catches the flash of a burglar's torch, to switch on lights at sunset so that your home looks occupied, as a shop door alarm, or as a lift door protector - the only limit is your imagination. Fun to build and use.

Cat. K-2632 ..... \$5.95

## METAL/PIPE LOCATOR

Now you can join the gold rush and learn about electronics at the same time by building this metal detector using the CMOS 4001 IC. Handymen will find it extremely useful for locating pipes and electric cables before digging holes or drilling in walls.

Cat. K-2633 ..... \$6.95

## SOUND ACTIVATED SWITCH

Designed to use a sensitive electret microphone, this device is ideal as an alarm pick up to actuate a bell or light at the first sound of intrusive noises. It may also be used as an extension bell for your telephone without breaking PBT regulations.

Easy but fascinating to build and use  
Cat. K-2634 ..... \$7.50

## HOME/CAR ALARM

This very practical circuit will teach you about electronics and at the same time provide you with an efficient alarm circuit for your home and car. May be used with any number of normally open or normally closed contacts.

Cat. K-2635 ..... \$6.95

## ELECTRONIC SIREN

The ideal project for providing the audible alarm for home or car circuits. Using two NE555 IC's this circuit can be easily modified to produce a variety of sounds.

Cat. K-2636 ..... \$4.50

## LED LEVEL DISPLAY

Build this project and obtain a graphic indication of the output of your radio or hi-fi system. You might like to build two - one for each channel of your stereo system. Power level is displayed by ten red LED's. Easy to build with direct practical application.

Cat. K-2637 ..... \$9.50

## INTERCOM UNIT

Now you can build your own home intercom using a simple circuit and the intercom amplifier described above.

Enables you to communicate between rooms or to out buildings. An interesting and useful project that will increase your knowledge of electronics.

Cat. K-2638 ..... \$9.50

## LED COUNTER MODULE

This fascinating project will introduce you to the workings of the 7 segment digital display. Using 7490, 7475, and 7447 IC's, it is easily adapted for industrial applications such as component counting as well as numerous other counting applications. A reasonably complex circuit that will build your confidence and increase your enjoyment in electronics.

Cat. K-2639 ..... \$8.50

## SHORT WAVE RECEIVER

Now, using this circuit with the 4007 IC you can build a short wave radio that will enable you to tune into foreign radio stations or, with simple adjustments, to a variety of Amateur, Police, Marine or Air radio.

Easy and fun to build and will greatly expand your knowledge of radio.  
Cat. K-2640 ..... \$7.50

## FLASHER

A really simple kit using two transistors and one light emitting diode (LED) to produce a flashing light that can be used to simulate a car burglar alarm or electronic brooch.

Cat. K-2621 ..... \$2.95

## DING-DONG DOORBELL

Delight your family and friends with this project designed around the NE555 timer.

Cat. K-2622 ..... \$4.95

## MORSE CODE TRAINER

This simple oscillator circuit coupled to a small speaker makes an ideal morse code trainer when used with a morse key and may also be used as an audible alarm by connecting it to an alarm output circuit.

Cat. K-2623 ..... \$6.50

Note: Morse key not supplied with this kit but is available as a separate part. Cat. D-7105 \$1.95

## UNIVERSAL TIMER

Use as an egg timer, photographic, or process timer etc. For times from a few seconds to 15 minutes. Maybe used to switch OFF or switch ON and operate a relay, speaker or buzzer.

Cat. K-2624 ..... \$5.95

available from our stores at:

NSW BANKST. SQ. 707 4888  
BLAKEHURST 546 7744  
BONDI JUNCT. 387 1444  
BROADWAY 211 3777  
BROOKVALE 93 0441  
CHULLORA 642 8922  
GORE HILL 439 5311  
GOSFORD 25 0235  
LIVERPOOL 600 9888

NORTH RYDE 88 3855  
PARRAMATTA 689 2188  
PENRITH 32 3400  
SYDNEY 27 5051  
SYDNEY 267 9111  
TAMWORTH 66 1961  
TIGHES HILL 61 1896  
WOLLONGONG 28 3800  
ACT Fyshwick 80 4944

VIC COBURG 383 4455  
FRANKSTON 783 9144  
GEELONG 78 6766  
MELBOURNE 67 9834  
RICHMOND 428 1614  
SPRINGVALE 547 0522  
QLD BRISBANE 229 9377  
BURANDA 391 6233  
CHERMSIDE 359 6255

TOOWOOMBA 38 4300  
TOWNSVILLE 72 5722  
SA ADELAIDE 212 1962  
DARLINGTON 298 8977  
ENFIELD 260 6088  
WA CANNINGTON 451 8666  
PERTH 328 6944  
PERTH 321 4357  
TAS HOBART 31 0800

Or from: Dick Smith Mail Order Centre, PO Box 321, North Ryde, NSW, 2113 Phone (02) 888 3200

# TWENTY EXCITING PROJECTS FOR YOU TO BUILD

## A pipe and metal locator

Before drilling into a wall and possibly hitting power cables or water pipes, check first with this handy metal locator.

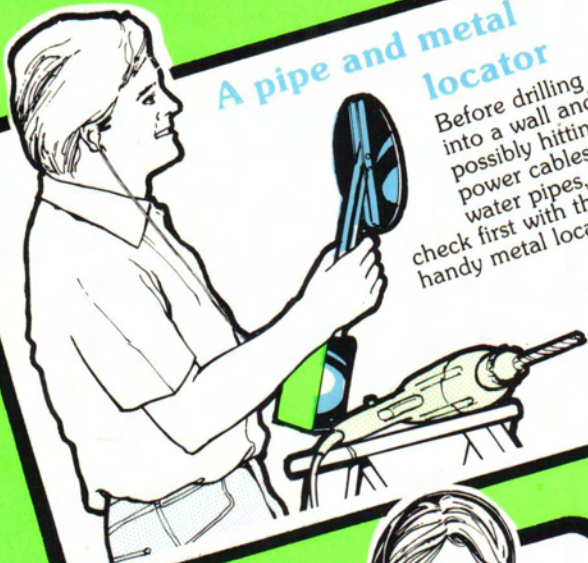

## Home and Car Burglar Alarm

We'll show you how to build a reliable alarm which you can use to protect your home, your car or your office.

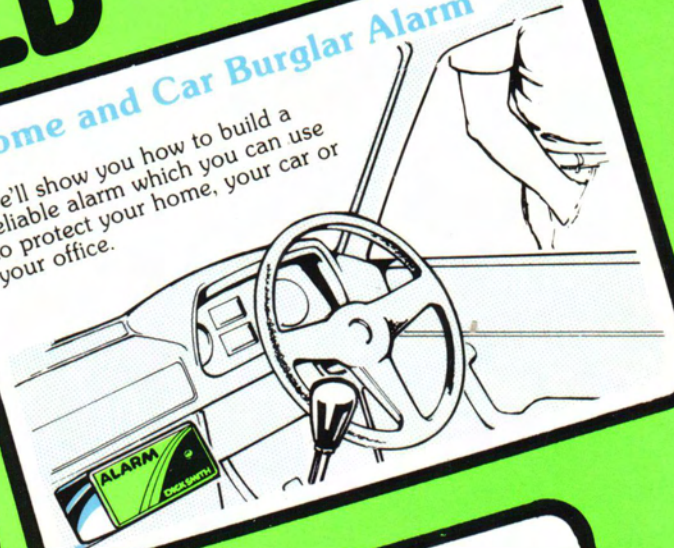

## LED Level Display

The latest thing in hi-fi: a display which shows the audio level by lighting LEDs. It's easy to build, and even easier to add onto your home hi fi system.

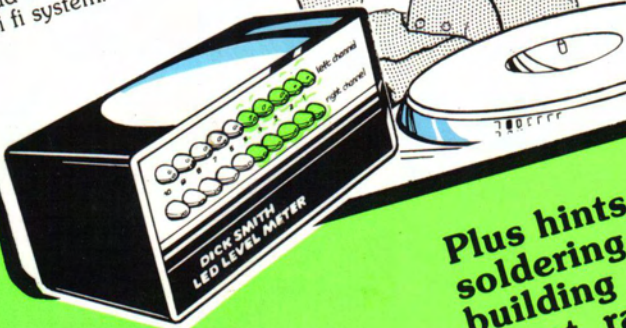

## Touch Switch

A single touch can turn appliances on and off, or you can have them on only while you're touching the plate. It's different - and it's in this book.



Plus hints and tips on using multimeters, soldering, making printed circuit boards, building projects . . . and information about radio, technical terms, interesting pioneers and great discoveries that have shaped the course of electronics.