

CIRCULATING CURRENTS: THE WARNINGS ARE OUT

UNDERSTANDING HOW TO AVOID OR MINIMIZE THE EFFECTS OF CIRCULATING CURRENTS CAN MAKE YOUR DESIGNS MORE ROBUST. EVERY ENGINEER SHOULD KNOW THE TECHNIQUES FOR NEUTRALIZING THIS INSIDIOUS PHENOMENON.

BY PAUL RAKO • TECHNICAL EDITOR

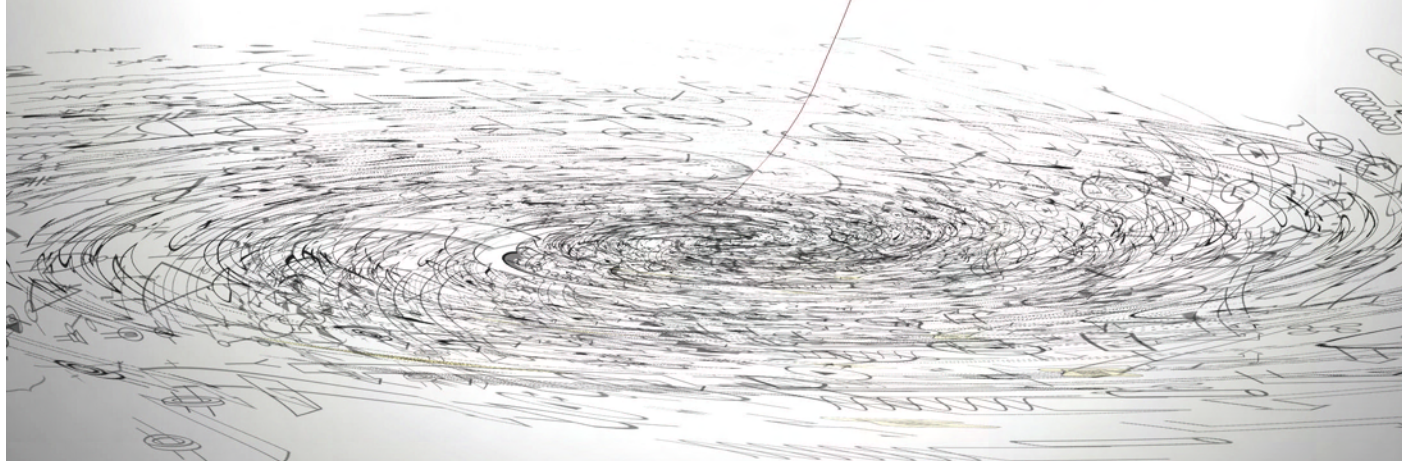

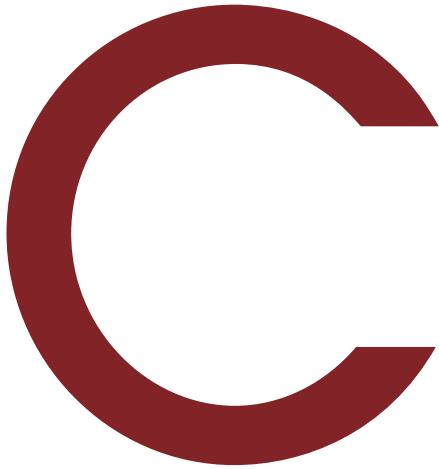

irculating currents can wreak havoc for a design engineer, no matter whether your application is computers or communications. Some engineers lack an appreciation for circulating currents because of the schematic convention of using a ground or common symbol to show the return path for all the circuitry. Novice engineers often mis-

interpret this symbol as representing an ocean of zero impedance. Nothing could be further from the truth. That ground symbol represents just another wire in your schematic. If the current in the ground connection is large enough or if it changes fast enough, it generates a significant amount of voltage. That voltage might interfere with the accuracy of a power supply. That voltage can also cause measurement errors in an instrumentation application. Digital-system engineers must grapple with ground bounce. Audio buffs see the

effects of circulating currents in the dreaded ground loop that causes buzz and hum. RF engineers always struggle with controlling the flow of ground currents in high-frequency-system applications. Read on to find out the cause of circulating currents, get some real-world examples, and then learn solid design principles to keep these circulating currents from ruining your design.

Even experienced engineers must remember that the ground or common symbols on schematics are just notational conveniences. A ground symbol represents just another wire, albeit a wire that has many connections. Even when the ground symbol represents a ground plane, a finite impedance will still exist, and it may interfere with the proper operation of your circuit. The key word is “impedance,” not simply resistance. Resistance of the ground circuit can cause problems in situations having sensitive nodes that microvolt changes affect. A more com-

mon problem is the impedance of the circuit, or the resistance it shows over frequency. This problem should be intuitive to even a novice engineer (see **sidebar** “Impedance 101: those old, familiar impedance equations”). A 50Ω coaxial cable shows milliohms of resistance when you measure it with a DVM (digital voltmeter). But at high frequencies, the cable has the advertised impedance of 50Ω .

It might now be helpful to plug and crank a few actual numbers through the old, familiar impedance formulas to demonstrate why ground connections depend so highly on impedance—not just resistance. A capacitance of 25 pF does not sound like a lot, but, at 100 MHz, the impedance formula gives a value of 64Ω . Knowing that video-signal impedances are often 300, 75, or 50Ω should give you pause when you consider that only 25 pF of stray capacitance provides an impedance of only 64Ω . In the realm of circulating current, the inductance is often the

cause of the problems. An inductance of 15 nH is a small value. An inch of wire in free space has about 15-nH inductance. Yet, at 100 MHz, that inductance has an equivalent resistance of 9.5Ω . Again, you can see that what appears to be an irrelevant stray has become a significant amount of impedance.

At first blush, these facts wouldn’t trouble many engineers. They would think that, because their switching power supply has a 200-kHz clock, they need not worry about impedance. However, they are misinterpreting the fundamental frequency of operation with the highest frequencies of interest in the circuit. Fourier analysis shows that a 200-kHz square wave can have frequency components in the hundreds of megahertz. To better understand these issues, consider the relationship of capacitance and inductance to voltage and current.

Once again, plug a few real numbers into the same familiar impedance equations. Looking at the stray capacitance between a circuit node and the substrate, a value of 2 pF is not uncommon in a semiconductor. ICs often have rise times of 1 nsec. If the part operates on 5V, the rate of change is 5V/nsec, or 5 GV/sec. Multiplying this figure by the admittedly tiny capacitance still yields a current of 10 mA. Every node that slews at this rate will dump 10 mA of supply current into the ground.

This aspect of circulating currents is just one of many. For example, examine the effect of a small inductance on that same IC. If all those stray ground currents add up to 100 mA and that current appears over the same 1 nsec, then the rate of current change is 100 MA/sec. A bond wire in an IC can easily have 2 nH of inductance. That current change across the bond wire creates 0.2V. This amount can affect the logic level or transition time. Don’t forget: The same transition occurs on the power rail and may cause its own problems (**Reference 1**).

With circulating currents, even small stray inductances and capacitances can

AT A GLANCE

❏ Circulating currents can plague power-supply circuits, audio circuits, and RF. Even IC designers must struggle with the effects of circulating currents.

❏ The ac impedances of your circuits are more important than the resistances when it comes to the trouble that circulating currents cause.

❏ The common, or ground, symbol on your schematic is just another wire—not an ocean of zero impedance.

❏ Power supplies have large output currents, as well as internal circulating currents. Keep the reference ground away from these nodes. Connect the supply circuit to your system at one point.

❏ Cutting up the ground plane usually causes more problems that it solves. However, as with all things analog, there are exceptions to the rule.

❏ You can avoid ground loops in audio and RF circuits with good design practices and differential-signal chains.

create large currents and voltages if the signals are moving fast enough. Because board-level Spice and other simulations often do not model these strays, the circuit performs flawlessly on the computer. On the breadboard or in production, however, the effects of circulating current can ruin your design.

Consider some real-world examples in which circulating currents can wreak havoc on your designs. Understanding the bad effects of fast-moving voltages and currents on IC designers, consider the grief that mixed-signal-system designers must endure. Digital circuits on silicon die inject amperes of current into the substrate during short transients. The same die may include delicate analog circuits, which have no noise margin. Worse yet, if the simulation and verification tools available do not model the strays to ground or the interconnect strays, the first silicon will not

work properly. It will then take many months if not a year to figure out the problems and redo the circuit. “Constraint rules that allow the communication of critical design intent from upstream circuit designers to downstream layout engineers are critical,” says Anthony Gadiant, marketing-group director for Virtuoso at Cadence Design Systems. “These constraints will allow designers to unambiguously communicate critical information, such as which devices need to match or which parts of a circuit need special isolation from noise injected into the substrate.”

Figure 1 shows the internal circuits in an IC and the inductance of the bond wire, as L_3 represents. The connections for the power and ground also have their respective inductances. Figure 2 shows the effect of ground bounce on digital-logic signals. Ground currents react to those stray inductances, causing overshoots, undershoots, and ringing. When fast-moving currents react to the ground pin’s bond wire, voltage appears on a ground pin. This problem prompted some manufacturers to revise their packaging to minimize the stray inductance in the ground circuit.

POWER SUPPLIES

Circulating currents cause problems in power supplies when the large output currents cause a difference between the actu-

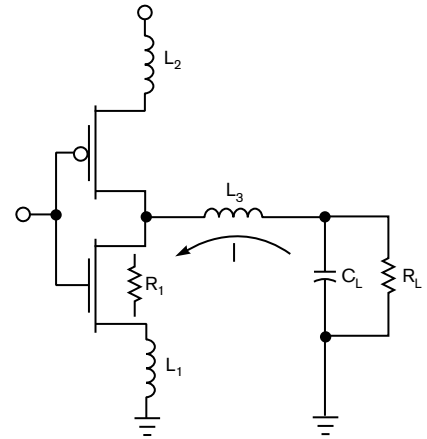

Figure 1 L_1 , L_2 , and L_3 represent the bond wires inside an IC. Fast-changing currents in these wires create appreciable voltages (courtesy Fairchild Semiconductor).

al output voltage and the feedback voltage as well as when the large output-ground currents move the power-supply chip’s analog ground off its true ground. They also cause problems when the large output currents in the supply’s power and ground rails interfere with the delivery of an accurate voltage to the systems and when the circulating currents are in loops that radiate excessive EMI into the system or cause the system to fail FCC (Federal Communications Commission)-compliance tests (Figure 3).

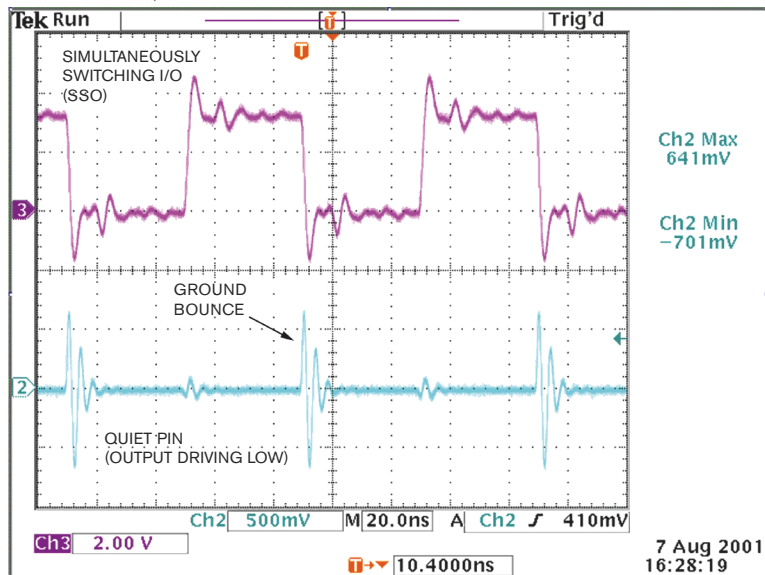

Figure 2 The ground bounce in the lower trace is large enough to cause false triggering of logic circuits (courtesy Altera).



In the figure, the feedback resistors are not to the left of the output capacitor because this placement would put the feedback sampling point along a trace with circulating ac currents. Instead, the feedback resistors sit to the right; alternatively, you could use a four-wire Kelvin connection of the feedback resistors to the output capacitor's pads (Figure 4 and references 2 and 3). You must also be sure to reference the internal voltage reference in the IC to the proper ground. If the reference ties to ground near the input capacitor or the synchronous switch—or diode in an asynchronous design—large,

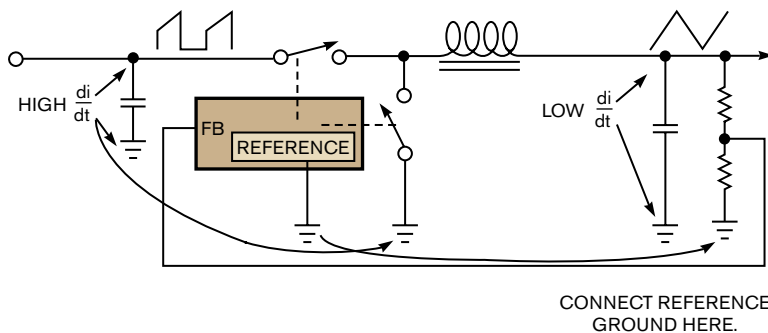

Figure 3 Buck regulators have large circulating currents in the input capacitor and the synchronous switch ground. Keep the reference ground away from those nodes.

IMPEDANCE 101: THOSE OLD, FAMILIAR IMPEDANCE EQUATIONS

Resistance is the well-known property of a resistor, but impedance is a frequency-dependent property that involves the capacitance and inductance of connections, as well. Every engineer should have committed to memory the equations that relate current and voltage in reactive components. Because voltage and current in inductors and capacitors are time-variant phenomena, you must invoke calculus to represent the behavior of these types of components. In calculus, the voltage of a node depends not on the dc current but on the time-variant change in the current, which you express using the differential di/dt , the change in current over time.

The basic nature of capacitors and inductors should allow a forgetful engineer to derive the relationship by inspection. The larger the capacitance and the faster the signal changes, the smaller the voltage across a capacitor gets. This situation demands that you put both

the capacitive and the frequency terms in the denominator. Hence, for a capacitor, $Z=1/wC$, and radian frequency, w , is equivalent to $2\pi f$, where f is the frequency in hertz, or cycles per second. You therefore express the relationship between voltage and current for a capacitor as $Z=1/2\pi fC$. Conversely, the intuitive observation that an inductor becomes an open circuit at high frequencies provides the hint that the larger the inductance or the higher the frequency, the greater the effective resistance of an inductive circuit. Hence, for an inductor, the frequency and value appear in the numerator. The impedance of an inductor is therefore $Z=2\pi fL$.

At dc, or zero frequency, your intuitive feelings toward the inductor and capacitor become justified. The zero in the denominator of the capacitive equation means that the impedance of a capacitor at dc is infinite. Similarly, the zero in the numerator of the inductive

circuit means the impedance of an inductor at dc is zero. Real-world capacitors have a leakage current that provides a noninfinite impedance, and real-world coils always have a metallic resistance that means that the impedance is not zero. Circulating currents are not dc phenomena, but currents can cause problems at dc. More problems occur at high frequencies.

Engineers analyze and conceive of circuits using the voltage, rather than the current, at the various nodes. They think this way because oscilloscopes and voltmeters are easier to use to probe nodes than they are to determine the current in the branches of a node. Because voltage is so important, you want to solve for voltage in your reactive circuits. Your intuition tells you that the larger a capacitor is, the smaller the voltage change due to a current that you inject into the capacitor. Because a big capacitor implies a small voltage,

the capacitance must appear in the denominator. Remember: You are dealing with time-variant components, so the current term is not a dc term, but you express the rate of change of the current as di/dt , the rate of current change over time. Therefore, solving for the voltage across a capacitor yields $V=(1/C)(di/dt)$. Similarly, a larger inductor would have more voltage across it in response to a changing current, so that equation becomes $V=L(di/dt)$.

You can apply your intuition to solve for the current through a capacitor or an inductor. The forgetful need realize only that the current through a capacitor becomes larger with the value of the capacitor or the voltage change across it. This fact yields $I=C(dv/dt)$. Similarly, the larger the value of the inductor is, the smaller the current that forces itself through it will be. The inductance must appear in the denominator. That equation yields $I=(1/L)(dv/dt)$.



fast-moving, circulating currents will cause the ground reference to hop. John Dutra, member of the technical staff for field applications for National Semiconductor, points out that the fastest changing waveform that can exit from the side of the inductor that has no switch or diode is a triangle wave. That triangle wave is less troublesome than the high di/dt currents that circulate between the input capacitor and the synchronous switch. If the IC has a power ground, it can dump to this node, but the analog or

reference ground should tie to the output capacitor right at its ground, preferably sharing the Kelvin connection with the feedback resistor.

Once you place the feedback network to the right of the output capacitor and you tie the IC reference to the output-capacitor ground, you must present the power-supply output to the system. To control the currents in the ground plane, some engineers advocate cutting slots into it. However, many engineers find that approach to be a bad idea. If there

are currents that flow around the cut, it will create loop areas that radiate and cause other problems. It also limits the use of the plane as an RF shield.

“Controlling noise on a mixed-signal pc board can be a difficult problem,” says Henry Ott, president of Henry Ott Consultants. “This situation is especially true on boards with multiple ADCs. Some designers suggest splitting the ground plane to isolate the digital ground from the analog ground. Although the split-plane approach can work, it has many

CIRCULATING CURRENTS IN AUDIO

Engineers often refer to circulating currents in audio as ground loops. Often, large currents in power stages interfere with the audio signal, much as the power current in power supplies interferes with the reference voltage. For example, a power amplifier boosts the output of a CD player, so that it will be strong enough to drive the speakers (Figure A). The application has a voltage regulator to step down the 12V on the board to 5V that the CD player needs, but the figure omits this detail. Many CD players work well

with this design, but others exhibit unacceptable noise in the audio. These players had poor internal layout and small capacitors in the power supply.

Figure B rearranges the system to show the flow of large currents through the CD motor. Resistor symbols replace the wires, but ac impedance, rather than simple resistance, causes the signals that interfere with the audio.

Power enters the power-amplifier pc board from the top. The figure also omits the regulator on the pc board. The resistor represents the

impedance of the board traces. The next resistor represents the impedance of the cable that brings power to the CD player. Yet another resistor represents the impedance of the traces on the CD player that go to the positive terminal of the motor. There are corresponding impedances below the motor. The figure also shows wires for the ground connections to the amplifiers in the CD and the power-amp board. These wires also have impedances, and you should also consider those impedances, espe-

cially the ground from the board amplifier because it carries higher currents to power a speaker. For simplicity's sake, only the motor's power wires show equivalent impedance. Those impedances are all that are necessary to explain the audio noise.

Only certain players had audio-noise problems because they have poor internal grounding and small power-supply capacitors. The figure shows the amplifier ground coming off the bottom of the CD player's internal impedance. But, if the player's designer had laid out the board so that the amplifier ground was at the negative terminal of the motor, things would be even worse. That approach would result in three equivalent impedances reacting against the motor current to add noise to the amplifier's ground reference. Just as deleterious, the use of small capacitors in the CD power supply ensures that ac currents end up in the audio chain.

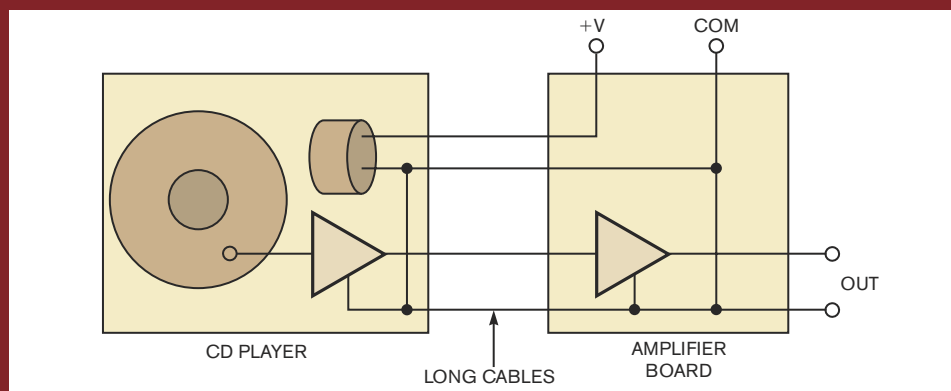

Figure A An amplifier board, which supplies power to the CD player, also creates an audio-ground loop.

potential problems. By understanding how and where high-frequency ground currents flow, it is usually possible to develop an approach to controlling noise and, in most cases, still maintain a single contiguous ground plane. Component placement and partitioning, combined with routing discipline—not splitting the ground plane—are the keys to success in laying out a mixed-signal pc board.”

In the case of power supplies, it may be a bad idea to just nail every ground node to the plane even if you have placed the

components to reduce the effects of circulating currents. Four-layer boards are now ubiquitous, and many engineers are now working on six- or eight-layer boards. You can take advantage of these layers to keep a ground plane that has minimal circulating currents. A simple technique exists even for two-layer boards: Tie together the ground nodes with ac-circulating currents on the top layer of the board. Alan Martin, principal field-applications engineer at National Semiconductor, reports that the best approach is

to then tie that ground to the ground plane with only one via and to place that via at the ground pad of the output capacitor. This approach eliminates all ac-circulating currents from the ground plane and presents a regulated voltage at the output capacitor because the feedback network and the IC reference also connect to this pad.

Figures 5 and 6 show an example of this philosophy in practice. This buck regulator uses a Linear Technology 1.25-MHz LT1767 step-down regulator on a

If you imagine farads of capacitance in the player, then you can see that only dc would be in the cable and pc-board impedances. The CD-player motor could go on and off, the audio could get loud and soft, and the capacitance would smooth those ac pulses out so much that the response would be less than 20 Hz and undetectable to the human ear as well as below the cut-off frequency of the signal chain. A dc error would exist, and current would still flow in the ground loop, but it would be dc current and the signal would lack ac power currents. The decoupling of the amplifier in the CD player doesn't reduce this noise. Instead, the entire CD player must have massive capacitance to smooth out the current pulses in the motor circuit. Remember that CD players often buffer the data, and the motor can turn on and off periodically. This case caused the noise that appeared in the audio chain. In this case, star grounds

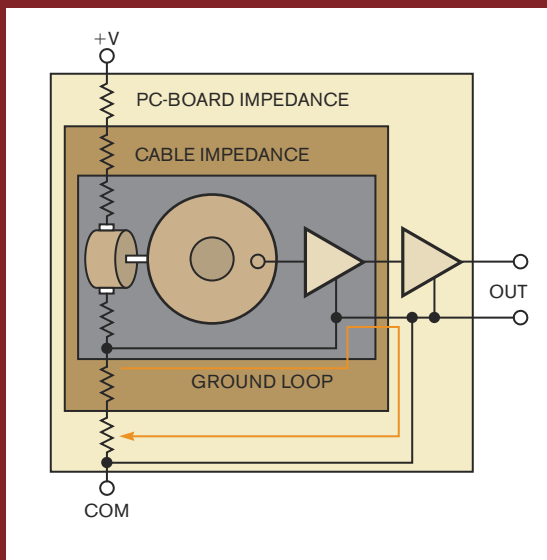

Figure B The pc board encloses the CD player in a ring.

or 5-oz copper planes will not help, and the impedance of the cable is certain to cause problems. Because a designer cannot dictate which brands of CD players connect to the system, he should make the audio input a differential connection by using an input transformer, a differential input amplifier, or an integrated chip, such as the Rohm BA3121 ground-loop-eliminator IC (Figure C).

Audio fanatics have long insisted that star grounds are the only acceptable grounding system. The advent of complex audio chains, including DSPs and Class D amplifiers, has taken the luster off the star-grounding system. Although star grounds can eliminate ground loops on a board, they also increase the impedance of all the grounds on that board. There are

many star-grounded audio amplifiers that break up into oscillation at the least provocation. Skip Taylor, chief technology officer of D2Audio, recommends that the company's customers “maintain continuous ground planes and use placement, appropriately split power planes, and topside pours to manage the currents' effect on the signal!”

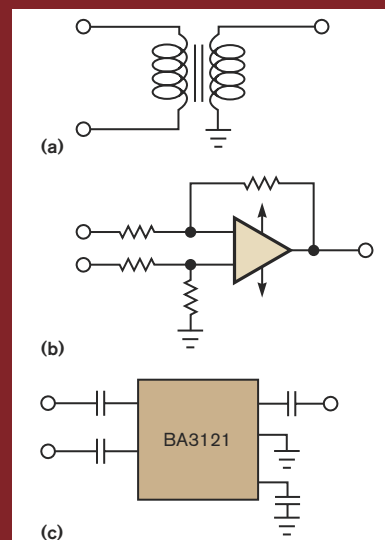

Figure C You can stop ground loops with the transformer (a), the differential amplifier (b), and the ground-loop eliminator (c).



four-layer board. In this layout, the bottom of the board is grounded but serves as a shield to other sensitive circuitry that is right below the board. The power supply connects to this circuitry at the ground pad of the output capacitor. The next layer up has just two connections: the output from the ferrite bead to the system and the connection between diode D_1 and capacitor C_3 . The next layer up also ties to the ground at the output capacitor. In addition, this plane provides the connection for ground between the IC and the circulating node of C_2 , D_2 , and C_5 . The circulating currents are in close proximity, and the currents enclose a minimal area. The switch in IC_1 is as close as possible to C_2 and D_1 , where the worst circulating currents are. The connection between C_2 , D_2 , and C_5 uses a copper pour to remove heat from diode D_2 , which is the hottest component in the system. Similarly, the ground for IC_1 is as large as possible. The via that ties it to the gray plane allows that plane to remove heat, as well. Note that the via for the IC does not connect to the plane. That plane has no circulating currents in it and serves as a shield. This design is currently in production and displays some of the cleanest, sharpest waveforms of any high-speed, high-performance buck regulator.

You can apply the same principles to a

boost or SEPIC (single-ended-primary-inductance) regulator. **Figure 7** shows that topology and the commensurate principles for a good design. “You will never regret designing isolation into your power supply,” says Martin. Isolation can help localize circulating currents on the primary and the secondary sides, respectively. **Figure 8** shows that the isolated converter has the same requirements for the feedback network. The feedback-resistor ladder should not connect to the trace between the rectifier and the output capacitor, and a Kelvin connection would be useful. Also note that the reference in the IC and the isolated primary-side feedback should be close to each other and out of the path of the circulating currents in the switch and the input capacitor. The **figure** shows stray capacitors, which cause the additional issue with the isolated supply. The package tab of the switch transistor is the collector or drain, and that node is flying back with the primary winding when the switch opens. This fast dv/dt can inject current into the case of the power supply—that is, earth ground. A stray interwinding capacitance in the transformer allows the injection of current into the secondary, and it can charge the secondary to dangerous voltages if the secondary does not tie to earth or some other reference, at

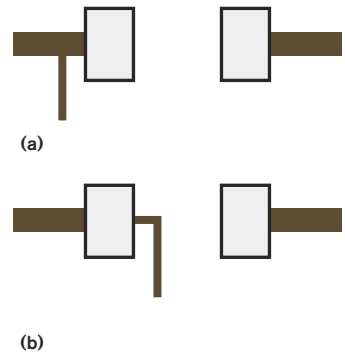

Figure 4 Instead of a conventional connection (a), use a Kelvin connection (b) to ensure that no circulating or dc currents flow in the sensing trace running from the pads of a component.

least with a high-value resistor. The **figure** shows the secondary referenced to earth ground, which is often the case in system design. Thus, two sources of current are flowing in the product’s chassis, which can wreak havoc with ground-fault interrupters or cause errors in measurement equipment.

“You have to keep three things in mind,” says Paul Greenland, vice president of marketing at Enpirion. “A wire in space has an inductance of 15 nH/in. Therefore, keep traces short. That inductance will increase if the wire forms a

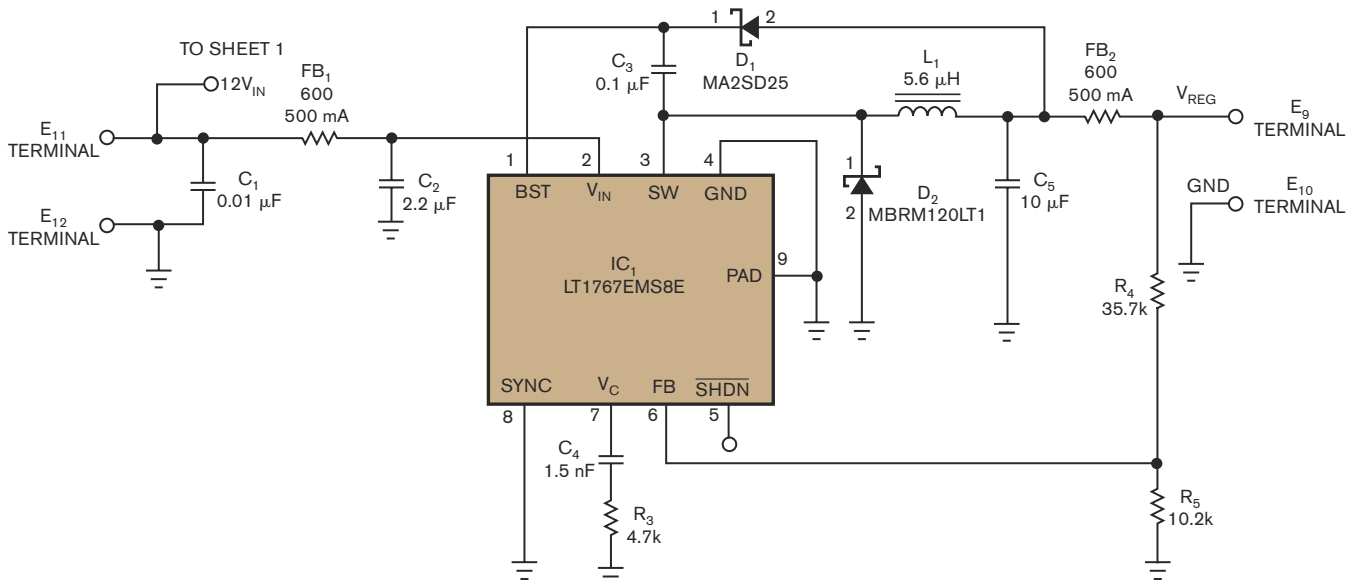

Figure 5 This 1.25-MHz buck-regulator circuit finds use in a high-volume consumer product.



loop. Therefore, keep loop areas small. Last, reduce field emission and susceptibility by routing traces so currents cancel.” (See Figure 9.)

CUTTING THE GROUND PLANE

It is usually a mistake to cut up ground planes (see sidebar “Circulating currents in audio”). There are ways to use placement and topside pours to keep nasty circulating currents from the ground plane. Meanwhile, the uniform planes provide the lowest impedance and can provide a valuable shield from RFI. In some cases, cutting the plane can yield good results, but you must be careful to analyze what you have gained and whether your approach is pertinent in a real-world system.

Paul Grohe, applications engineer at National Semiconductor, has developed a pc board that connects directly to the front of an HP3577A network analyzer (Figure 10). He uses this board to evaluate the gain and phase properties of the amplifiers that his group designs. This board exhibited good results, exceeding the accuracy, repeatability, and low noise of previous efforts, which used cut-up, copper-clad, handmade boards. Grohe achieved a noise floor of -110 dB using this system. This floor was important at the lower frequencies, when the network analyzer measured an error signal of $1 \mu\text{V}$ or less. Still not satisfied, Grohe took a knife to the ground plane on the board. By cutting the plane, he improved the noise floor to -130 dB. Anyone familiar with amplifier characterization and performance knows what a remarkable achievement this is. Figure 11 shows the system.

The HP3577A’s chassis common is the reference for the 50Ω source, as well as the input amplifiers. Grohe realized that the circulating currents use the connector ground on the reference input to return to the instrument. In a flash of inspiration, Grohe discovered that these currents could interfere with the measurement of the submicrovolt signals at that input. Because the single-ended HP3577A has a 200-MHz bandwidth, it was important to terminate the source with a 50Ω resistor. Grohe knew that the relatively large currents from this resistor

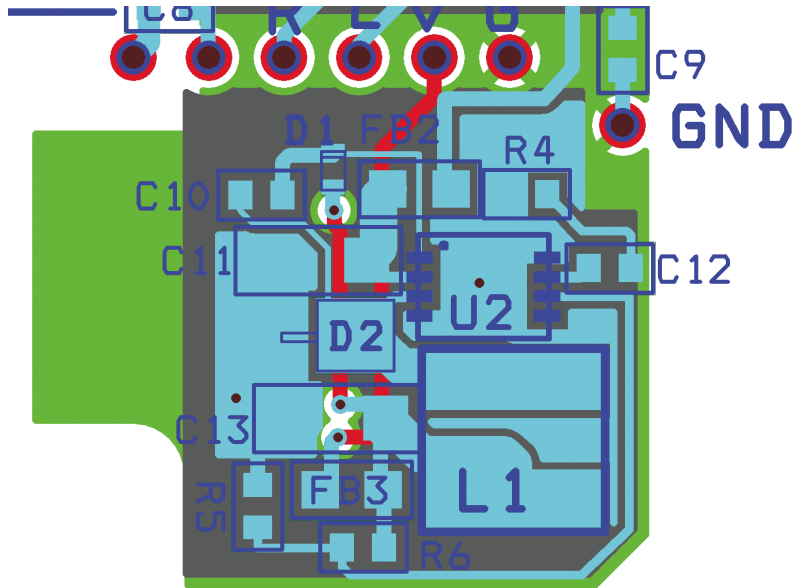

Figure 6 The pc-board layout of the circuit in Figure 5 demonstrates good design practice that minimizes the effects of circulating currents.

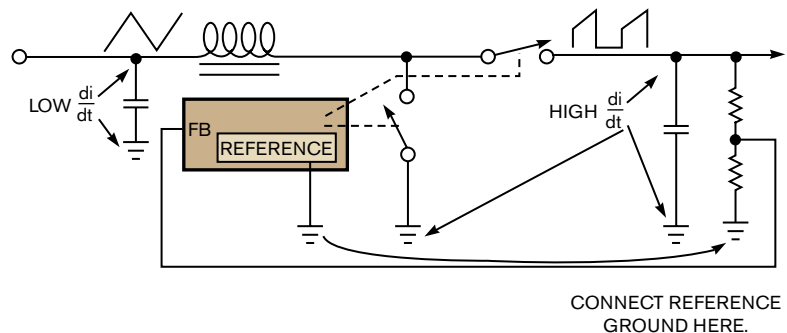

Figure 7 Boost regulators have large circulating currents in the output capacitor and the switch ground. Do not put the reference ground between those nodes.

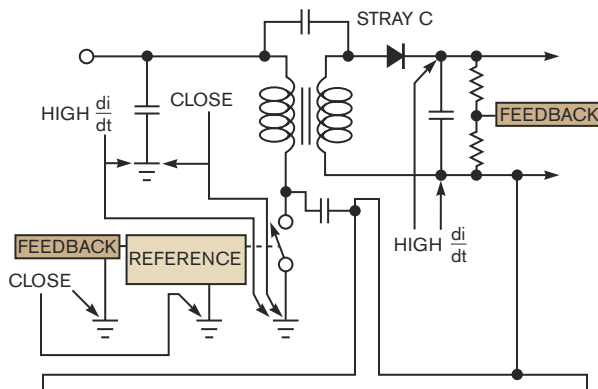

Figure 8 Isolated converters have large circulating currents. Stray capacitance between the transformer windings and between the switch case and the heat sink also cause circulating currents.

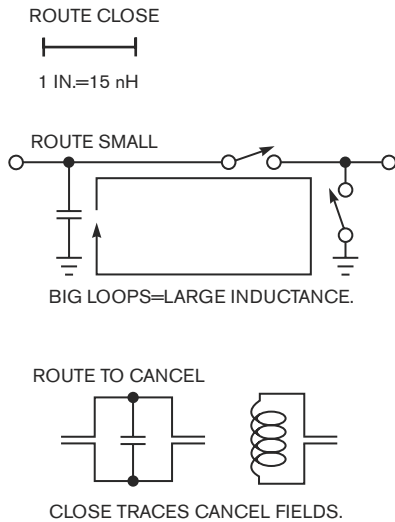

Figure 9 Small, tight layouts with canceling currents exhibit the best performance and provide low EMI/RFI emissions.

would seek “home” back to the analyzer by all possible connections. Because all three connections shared the same chassis ground, the current would return in the delicate R reference connector, as well as the source and A inputs. The interference with the A input was less serious because this input measures the output of the amplifier under test. This signal is large enough to resist interference. By cutting the ground plane around the amplifier under test, Grohe ensured

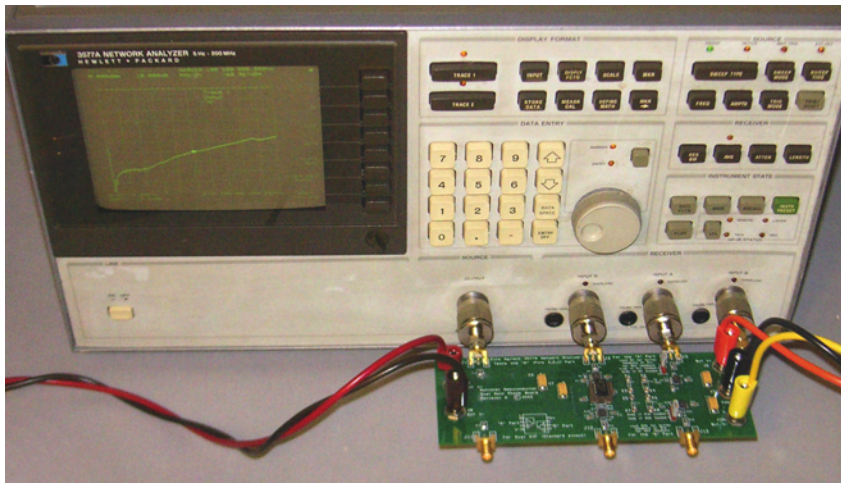

Figure 10 The gain- and phase-characterization pc board of the HP3577A network analyzer mounts directly on the front-panel connectors.

that none of the larger currents from the 50Ω source-terminating resistor would flow through the reference connector. This 20-dB improvement is testament to the principle that an engineer must think of the ground not as an ocean of low impedance, but as simply another connection to keep in mind for maximum performance.

In defense of the rule against cutting ground planes, you should note that cutting improved not the performance of the amplifier, but the measurement of a microvolt signal that is internal to the amplifier’s loop. Using a differential-input analyzer, such as a Ridley or a Venable, would also alleviate this issue of circulating currents. Unfortunately, those instruments target use in power-supply analysis and have bandwidths one-tenth that of the HP3577A. Before advocating cutting the ground plane in a production board, make sure that the improvement is not just an improvement in measuring and interfacing with test equipment and rather a genuine improvement in signal-chain performance.

CIRCULATING CURRENTS IN RF

RF engineers are well-aware of the headaches that circulating currents cause. Radio systems must often reference earth ground, and the components are single-ended. Figure 12 shows a coaxial cable connecting two RF subsystems. Because the cable must serve as an RF

shield, it must connect to the cases of the subsystems. If a large power usage in one subsystem injects current into earth ground, that current will travel along the coaxial shield and interfere with the signal on that coaxial cable. Diligent power-supply design can help in this case. Minimize current injection to the frame of the supply. Use electrostatic shields in the switching power transformer and between the FET switch and the supply case. Vicor takes this approach for most of its modules, and its products typically do not inject measurable common-mode currents.

Remember that power-supply return, chassis common, and shielding ground have different requirements. You should avoid using the system’s frame to return current, as you would in the design of an automobile. Every power supply should have its own return lines for the delivered current. In this way, the power leads form a loop with a smaller area and reduce EMI radiation. Ensure that this return does not connect to the frame of the system at various places. If that approach is unavoidable, those connections should be through common-mode chokes or, at least, ferrite beads. This approach reduces the higher frequency ac currents that are more likely to interfere with RF signals. Keeping the shield a shield instead of a power-supply return also ensures that the

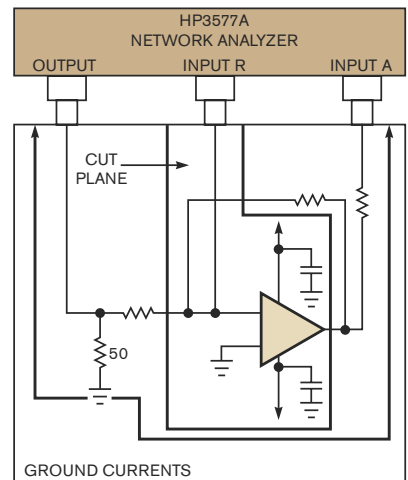

Figure 11 Cutting the ground plane on the gain/phase board routes circulating currents away from the R input, which measures microvolt signals.

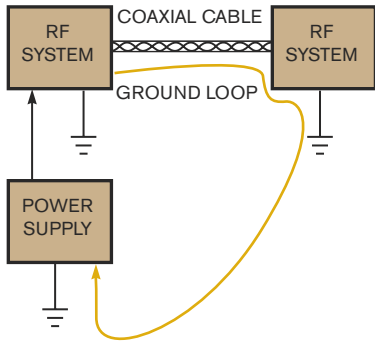

Figure 12 The power-supply current in RF systems often returns over the coaxial-cable shield, causing circulating currents.

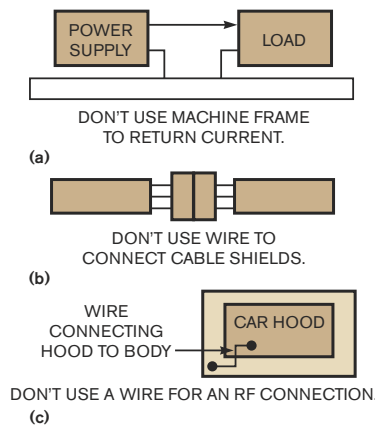

Figure 13 In a classic ground loop, the shield in the coaxial cable carries the power-supply current and interferes with the signal by inducing a series voltage drop in the outer conductor (a). You can also gather up the shields in a cable and solder a wire to them to pass the shield through a conventional amp-pin connector (b). You can use a wire to connect the hood of a car to the body, but RF signals easily pass through the gap between the hood and the fenders (c).

product has minimal RF emission, and, just as important, the machine will be immune to RF interference. Using the machine frame as a power-supply return is one reason that maintenance people cannot use FM radios in a semiconductor fab. Doing so may cause the machinery to reboot or act unpredictably.

More discussion of RF radiation and immunity is beyond the scope of this article. However, if you do not make the

MORE AT EDN.COM

For a recent *EDN* article that stresses the importance of minimizing loop area, go to www.edn.com/article/CA6347258.

For more on *EDN's* analog editor, Paul Rako, visit www.edn.com/info/1340007045.html.

errors that **Figure 13** shows, your system will be more robust. The problem is one of a classic ground loop, in which the shield in the coaxial cable carries the power-supply current and interferes with the signal by inducing a series voltage drop in the outer conductor (**Figure 13a**). This approach can cause million-dollar semiconductor machines to crash when you stand next to them and key in a radio. You can also gather up the shields in a cable and solder a wire to them to pass the shield through a conventional amp-pin connector (**Figure 13b**). However, at high frequencies, the inductance of that wire is a high reactive impedance. Also, the loops that form will act like small antennas to radiate and receive EMI. This approach can cause a semiconductor to fail CE (Conformité Européenne)-immunity certification because the RF currents circulate in the sensor side of the cable and give false signals to the microprocessor, causing the wafer-handling system, in turn, to shatter 25 wafers at once.

The situation in **Figure 13c** comes from the auto industry. It demonstrates the difference between a galvanic connection and an RF connection. You can use a wire to connect the hood of a car to the body, but RF signals easily pass through the gap between the hood and the fenders. The hole in a sheet of metal degrades shielding effectiveness and relates to the largest linear dimension of the hole compared with a wavelength. Placing several contacts around the periphery of the hood reduces the length of each hole. Again, at RF frequencies, the wire is a high reactive impedance. Mechanical engineers don't believe this fact because the ohmmeter displays 0Ω between the car body and the hood. This problem combines with the adoption of plastic inner fenders, causing no end of

grief to auto engineers trying to prevent ignition noise from interfering with radio reception.

James Long, an analog and RF consultant, advises clients: "Remember that current flows in closed loops, as Kirchoff's current law dictates. Also, current takes the path of least impedance. At RF, this is inductive reactance. It chooses the path in which the inductance of the loop is smallest, which means that it encloses the smallest area. Using these rules, you can visualize where the current will flow and what secondary effects it will have." Long also advises that you can encourage the current to flow where you want by placing the going and coming conductors close together and away from areas in which the return current would cause harm.**EDN**

FOR MORE INFORMATION

- | | |
|---|---|
| Altera Corp
www.altera.com | Henry Ott Consultants
www.hottconsultants.com |
| Analog Devices
www.analog.com | James Long Consulting
www.analog-rf.com |
| Cadence Design Systems
www.cadence.com | Linear Technology
www.linear.com |
| D2Audio
www.d2audio.com | National Semiconductor
www.national.com |
| Enpirion
www.enpirion.com | Rohm
www.rohm.com |
| Fairchild Semiconductor
www.fairchildsemi.com | Vicor
www.vicr.com |

REFERENCES

- 1 "Understanding and Minimizing Ground Bounce," Fairchild Application Note AN-640, February 2003, www.fairchild-direct.com/an/AN/AN-640.pdf.
- 2 Kelvin (4-wire) resistance measurement, All About Circuits, www.allabout-circuits.com/vol_1/chpt_8/9.html.
- 3 Varga, Craig, "Improved Kelvin contacts boost current-sensing accuracy by an order of magnitude," *EDN*, Feb 17, 2005, pg 80, www.edn.com/article/CA502424.

You can reach Technical Editor Paul Rako at 1-408-745-1994 and paul.rako@reedbusiness.com.

