

A Pseudo Cursor FOR OSCILLOSCOPES

Add a calibrated time base to dual-trace scopes

By D. E. Patrick

KNOWING the exact timing relationships between points on a signal displayed on a dual-trace scope is a function of the accuracy (linearity) of the sweep used. In most cases, this can reach 3% or so, dropping to much higher percentages in older and uncalibrated instruments. Unfortunately, most electronics experimenters seem to have uncalibrated scopes in daily operation. As a result, the graticule markings are almost relative.

The "Pseudo Cursor" described in this article can overcome this problem. It's the second trace of a dual-trace instrument and will display a "picket-fence" of narrow, spiked pulses, with each pulse an accurately known time interval from its neighbor. The pulses can be arranged so that every alternate, or every fifth pulse, is emphasized to

make timing interpolation easy. Since the pulses are derived from a crystal-controlled oscillator, pulse interval spacing and thus, timing accuracy can be known to (typically) 0.002%.

Circuit Operation. As shown in the block diagram of Fig. 1, the dual-trace scope is set up so that one trace is synchronized with the signal of interest. Since a common time base is used, the second trace is also synchronized. The second trace vertical amplifier is connected to the output of the Pulse Generator.

The Pulse Generator, in turn, accepts pulses from a crystal-controlled time base, then converts them into very spiked pulses that

are applied to the second trace of the scope. Since the Pulse Generator is synchronized to the scope sweep circuit (via the sweep gate signal), the "picket fence" generated on the second trace is locked with the signal under observation. If the time interval between pulses on the picket fence is known, any interval on the signal under observation can be measured. Since the pulse interval timing is based on a crystal-controlled oscillator, their spacing interval can be as accurate as the crystal used—typically 0.002% or better.

A circuit within the Pulse Gener-

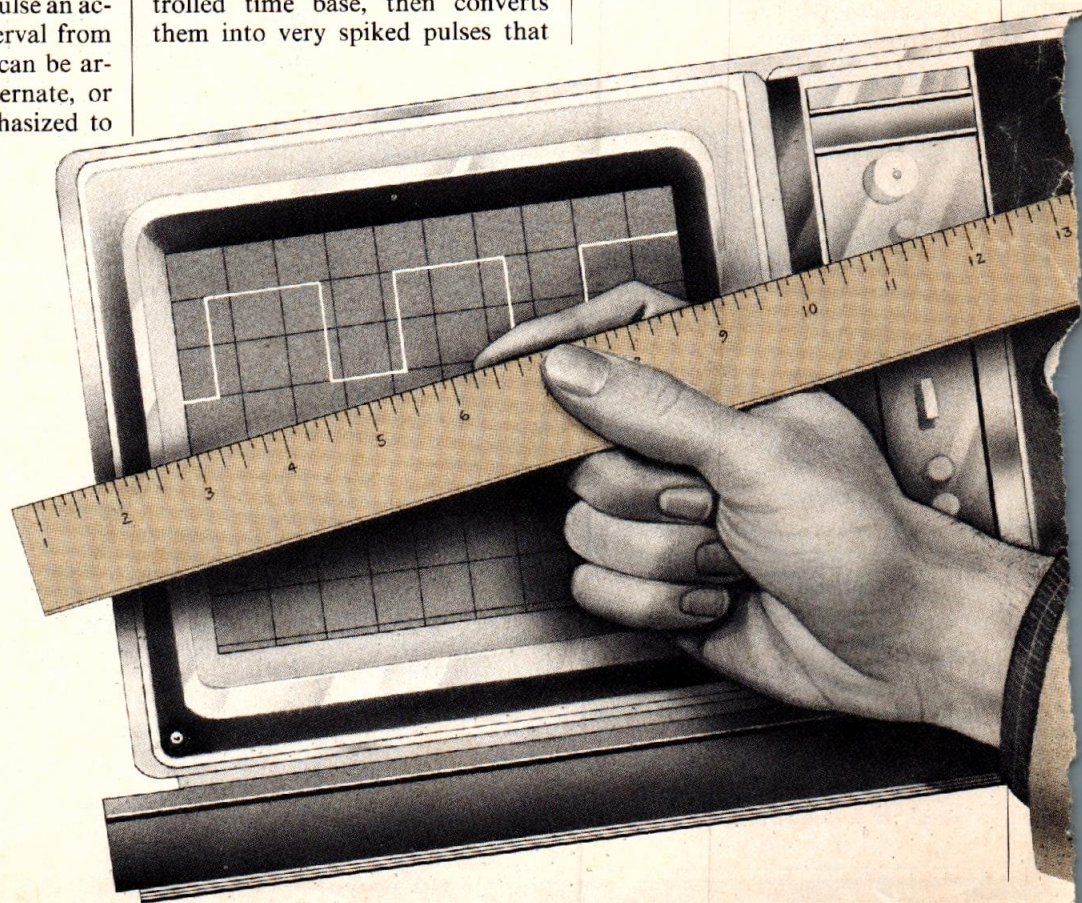

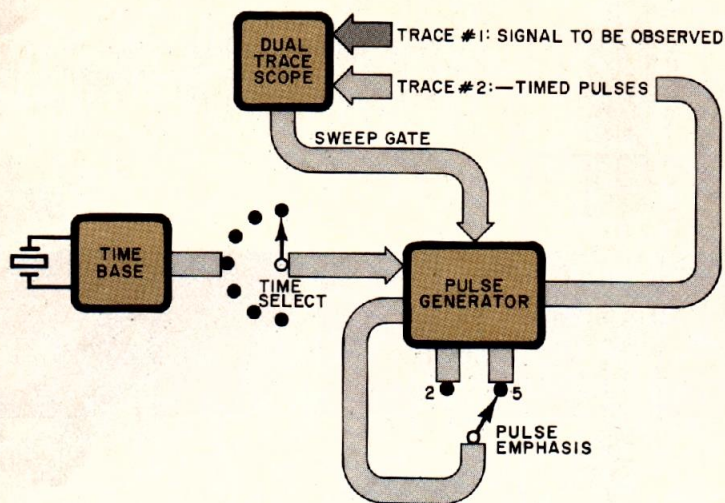

Fig. 1. One trace is synchronized with the signal of interest. The second is connected to the output of a pulse generator.

PARTS LIST

- C1—10-to-40-pF capacitor. Can be eliminated (along with R9) above 1 MHz
 - IC1, IC2—7490 decade counter
 - IC3—7406 open-collector hex inverter
 - IC4—7400 quad 2-input NAND gate
 - Q1—2N3904 or similar
 - Q2—2N3906 or similar
 - R1—100-ohm to 1-megohm resistor (see text)
 - R2, R5, R7, R8—1-kilohm resistor
 - R3—470-ohm resistor
 - R4—4.7-kilohm resistor
 - R6—820-ohm resistor
 - R9—100-kilohm potentiometer (see C1 above)
 - S1—Four-pole, double-throw switch
 - S2—Spdt switch
- Note**—The following is available from **Electronic Technical Consultants, POB 29278, Denver, CO 80229**: complete kit of parts at \$34.95 plus \$3.50 for shipping and handling. Also available separately are the pc board at \$8.00 and the power supply at \$10.00.

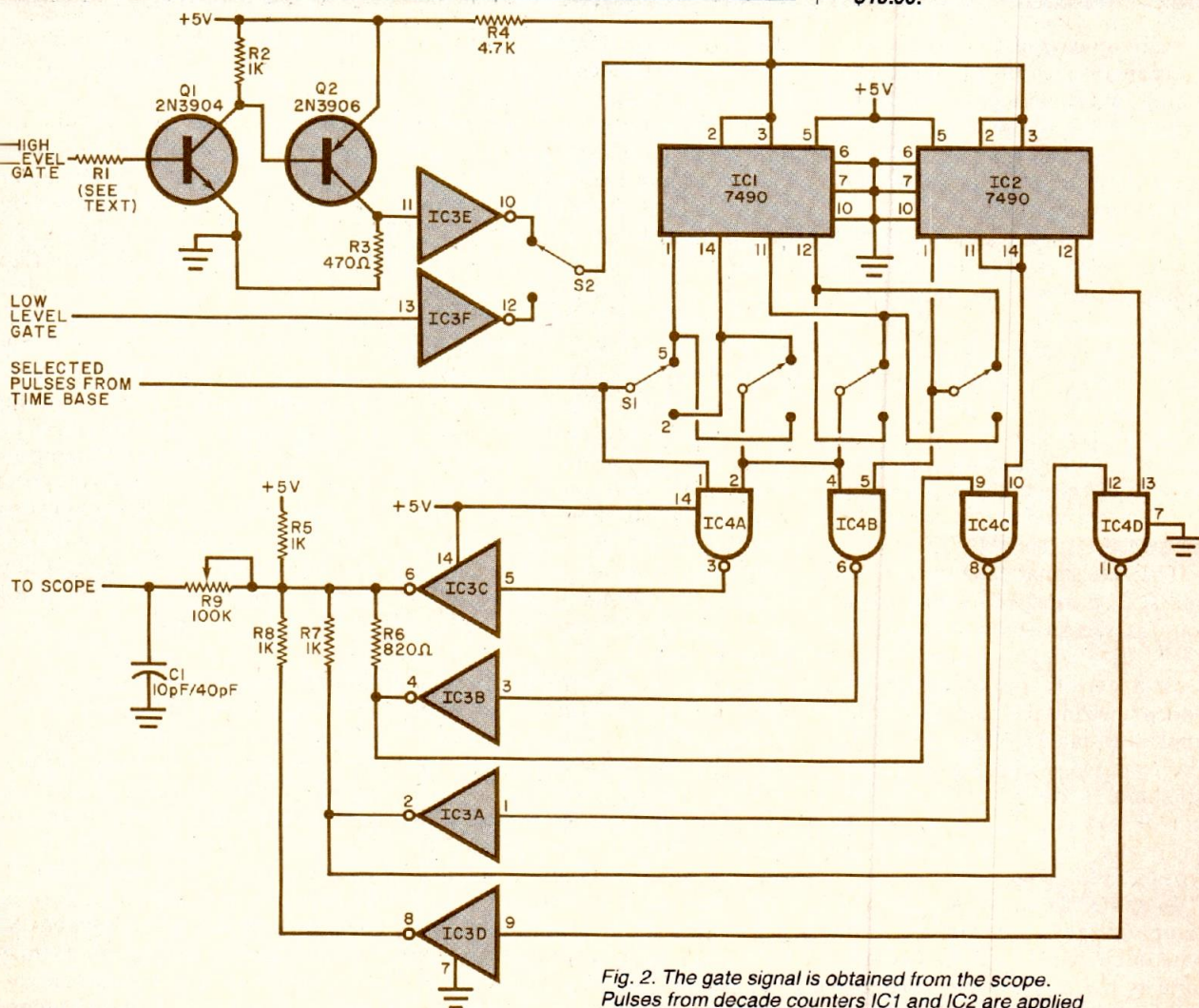

Fig. 2. The gate signal is obtained from the scope. Pulses from decade counters IC1 and IC2 are applied to a D/A converter formed by R5 and R8. Potentiometer R9 and capacitor C1 can be omitted for clock pulses above 1 MHz.

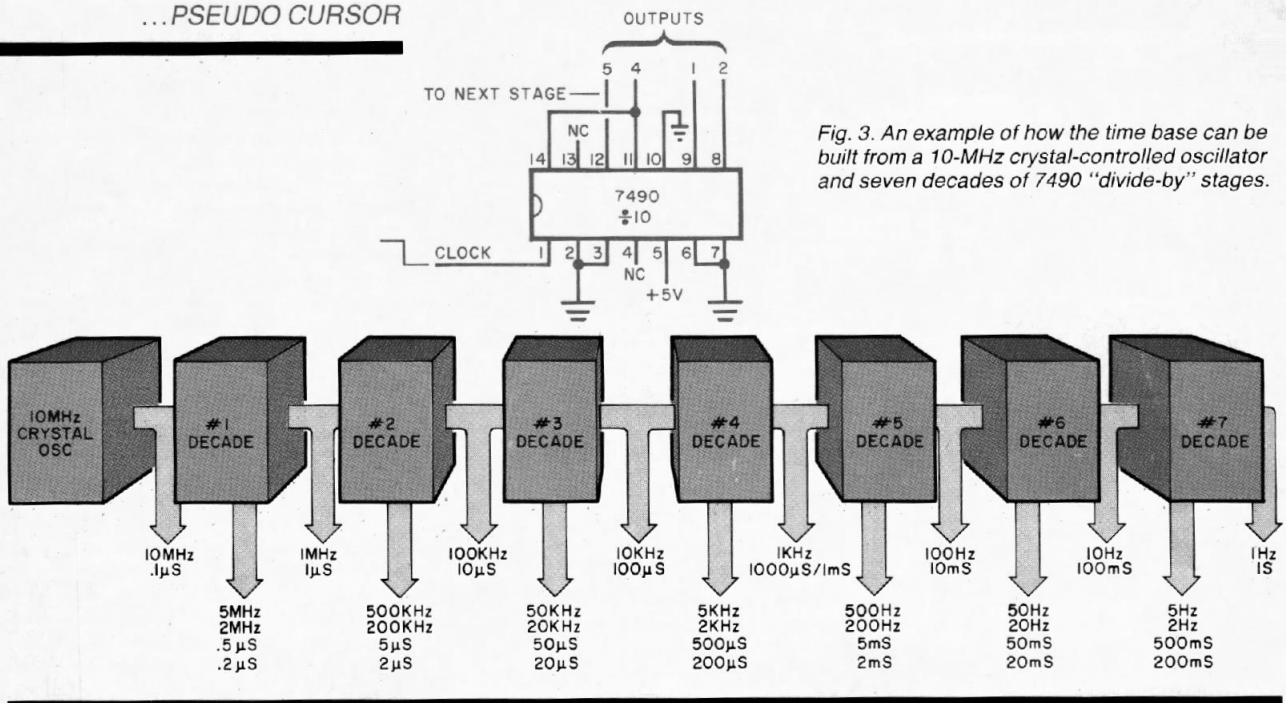

Fig. 3. An example of how the time base can be built from a 10-MHz crystal-controlled oscillator and seven decades of 7490 "divide-by" stages.

ator allows emphasis of either each alternate or each fifth pulse to ease timing interpolations. A selector switch within the time base allows almost any time interval to be selected. The circuit of the Pulse Generator is shown in Fig. 2.

In operation, decade counter *IC1* continuously accepts the selected timing pulses from the time base at its counting (pin 1) input. Both *IC1* and *IC2* have their outputs set to all zeroes if their 0 SET (pins 2 and 3) is high and will start counting when these pins are made low. This is how both decade counters are forced to start from zero at the beginning of each sweep, and count up during the sweep.

The gate signal used to turn *IC1* and *IC2* on must be in existence as long as the sweep is crossing the CRT. In a triggered sweep scope, such a gate is available from the sweep horizontal circuit and can be applied to pin 13 of inverter *IC3F*. For example, such a signal is available in a Heath IO-4510 at *IC40A*, pin 9 or pin 8, while in the Tektronix T922 it is available at pin 3 of *U2334A*.

In some cases, the actual sweep ramp voltage can be applied to the base of *Q1* which will remain on as long as the ramp voltage is higher than the *Q1* turn-on voltage. Resistor *R1* in series with the base of *Q1*

can range from 100,000 ohms to a megohm or so, depending on the level of the ramp.

Thus, contingent on the amplitude of the gating signal, either the low-level input consisting of *IC3F*, or the high-level input formed by *Q1*, *Q2*, and *IC3E* is selected.

The output at pin 12 of *IC1* can be used as the trigger for the second decade counter, *IC2*. Since the ICs used for *IC1* and *IC2* are biquinary (divide-by-2/divide-by-5) decade counters, switch *S1* can be used to select either of these division modes. With switch *S1* in the position shown, each fifth pulse on the second trace will be emphasized. If the user prefers one or the other of these emphasis modes, *S1* can be removed from the circuit and the pins of *IC1*, *IC2*, and *IC4* can be wired accordingly.

NAND gates *IC4A* through *IC4D* accept the various division outputs of the two decade counters, and apply their NAND outputs via inverter elements within *IC3* to a rudimentary digital-to-analog converter formed by resistors *R5* through *R8*. The composite signal is applied to the second trace input of the scope via an optional low-pass filter produced by potentiometer *R9* and capacitor *C1*. This filter can be deleted when clock pulses above 1 MHz are being used. In use, *R9* is

adjusted for a clean "picket fence" display on the second trace of the scope.

The time base can be built up from any type of 10-MHz crystal-controlled oscillator capable of driving a TTL load, and followed by as many "divide-by" stages as desired. In the example shown in Fig. 3, note that, with a 10-MHz oscillator and seven decades of 7490 countdown, intervals from 0.1 microsecond to 1 second can be measured with crystal accuracy. If desired, other counting chains can be used. For example, a 7492 can produce a divide-by-2/divide-by-6; a 7493 can produce a divide-by-2/divide-by-8; etc. Any TTL handbook will show how to build almost any modulo counting chain desired for almost any application.

Construction. Since the circuits are not critical, any type of construction can be used from point-to-point wiring to the design, etching, and drilling of a small pc board. As previously mentioned, selector switch *S1* may be removed after a choice is made to whether every alternate or every fifth pulse is to be emphasized. Likewise, switch *S1* and the unused gating circuit may be eliminated once the correct gating signal is found within the scope being used. ◇