

Digital IC TESTER

W. ENGLISH

LIFE is made much easier by using digital ICs to build up electronic circuitry, but it can be awkward if their condition is below specification. This simple, effective and very versatile instrument ensures that "good" ICs are in fact serviceable (the odd one can prove to be partly faulty) and can also sort out bargains from "Untested Packs". Even "Unmarked Packs" can be a source of useful cheap components, and a technique to deal with these is described at the end of the article.

The instrument was developed after a study of manufacturers' parameters, the requirements then being worked up in a practical form covering all anticipated objectives, retaining the original idea of simplicity.

Circuit details

Supply voltage, logic "0" and logic "1" levels are basic. Switchable levels are needed, and are taken from a Square-wave Multivibrator Clock circuit, Fig. 1, which is a preferred means of testing Decade counters. Indication of outputs is done by using LEDs and all functions readily routed to any of the 14 or 16 pins of the IC. This routing is simply achieved with flying leads from a 16-pin DIL socket, terminated by pins which plug into sockets providing the required reference levels.

For simplicity, the logic "0" is commoned to the Ground (negative supply). Logic "1" comes from one gate, both inputs grounded, of an SN7400. Two gates cross-coupled form a Clock multivibrator, frequency 90Hz, with a good squarewave, timing being monitored by a LED driven by the alternate half-cycle to that used for the Clock output. The fourth gate is used to produce trigger pulses needed when testing monostables. Both inputs are normally unconnected making the output logic "0", and a quick press and release of switch S2 momentarily connects the inputs to ground, providing a short logic "1" pulse. This is now fed to a sharply differentiating circuit producing very short +ve and -ve pulses at sockets marked "J".

LEDs 1, 2, 3 and 4 are driven by logic "1" outputs. LED 5 is for a logic "0" output, and its uses are described later. The limiting resistors R1-R4 are 470 Ω , which provide sufficient light with economy, although LEDs can vary and another value could be substituted.

The supply switch S1 is also spring-loaded, with the practical advantage that when inserting and extracting ICs both hands are needed, and the test is therefore "dead" during these operations.



The leads from the front panel are arranged in the same pattern as the DIL connections, which helps in setting up. They are numbered in two colours, to cover use of 14- or 16-pin ICs. As an additional aid, the leads 15 and 16 are in red and the leads for 1-7 are yellow. Leads for 8-14 (10-16) and green.

It is necessary to measure the current drawn, and provision is made to clip leads from a multimeter, set to 100mA, to sockets L and K.

Operation

The Table of Connections, Fig. 2, covers a sample range of ICs and for convenience Special Notes are appended. After a few trial runs, operation of the unit will become easier, and it can be left to the user to explore the infinite possibilities using ICs not on this necessarily short list.

Taking the 7400 as an example, the connections to the sockets are made, then checked, after which the IC is fitted. S1 should now be pressed and LEDs 1, 2, 3 and 4 should come ON and OFF in phase with the Monitor LED 6. If a lamp does not light the particular gate is faulty, and may be presumed open circuit. The current drawn for a good 7400 should be 8-10mA, although if a lamp fails to light and the current taken is 40-60mA or more, that gate is short circuit and the IC should be discarded. If one of the lamps is less bright than the others, that gate has a lower output, but may still be used, perhaps in a selected position.

Special Notes

- 7400**—LEDs 1, 2, 3, 4 in phase with Monitor LED 6.
7403—Set up as 7400, but open circuit collectors. Gates function when taken to socket E (logic "0").
7404—Test 4 gates, then remove (3 and 4) and set up (5 and 6).
7401—NAND open circuit collectors—use socket E (LED 5).
7402—NOR gates—LEDs out of phase with Monitor LED 6.
7470—As set up, LED 1, (Q) ON, LED 2 (\bar{Q}) OFF. Then change J and K connections as second row, when Q will be OFF and \bar{Q} will be ON.
7474—As set up, LEDs 2, 4 (\bar{Q}) ON. Pull out pins 2, 12—LEDs 1, 3 (Q) ON.
7490—(a) LED 1 (D output) ON once after 10 cycles of Monitor. This is decade configuration.
 (b) After Monitor cycles 5 times, LED 1 is ON for 5 cycles. This is BI-QUINARY configuration. (The outputs of extraneous gates may be observed, and the different configurations fully analysed.)
74107 Dual J-K Master/Slave Flip-Flop. As set up LEDs 2, 4 are ON, then change over—LEDs 1, 3 now ON. Change J/K connections as in second row, when LEDs 2, 4 are ON, and stay on.
74121 Monostable. With S1 pressed, LED 2 (\bar{Q}) is ON. Press and release S2, LED 2 goes OUT and LED 1 comes ON for about 2 seconds, then goes OFF, when LED 2 will again be ON. This tests the internal resistor (2k), but if a

★ components list

Resistors

R1 470 Ω	R6 4.7k Ω
R2 470 Ω	R7 470 Ω
R3 470 Ω	R8 470 Ω
R4 470 Ω	R9 1k Ω
R5 4.7k Ω	All 10% $\frac{1}{4}$ W except R9

Capacitors

C1 100 μ F 6.4V	C3 100pF ceramic
C2 100 μ F 6.4V	C4 1000 μ F 4V

Semiconductors

IC1 SN7400
 LED's 1 to 6 0.2in Red.

Miscellaneous

S1, S2, miniature SP biased push-to-make, 26, 1mm sockets (Doram no. 444 056). 16, 1mm plugs (Doram no. 444 034). 16pin DIL socket. Plywood for console. Veroboard, 0.15in plain 89 x 57mm, 0.1in clad 6 x 8 holes, 0.1in clad 7 x 7 holes. Wire, 18 and 22SWG tinned copper.

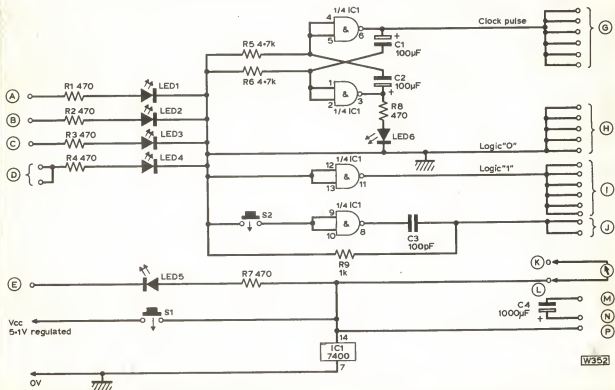

Fig. 1: Full circuit diagram of the tester, showing the various facilities available from the one internal IC. LED's 1 to 4 indicate logic '1', LED 5 indicates logic '0', while LED 6 is the Monitor indicator.

Table of Connections (Fig. 2)

Type to be Tested	Pin numbers																
	1	2	3	4	5	6	7	8	9	10	11	12	13	14	15	16	
7400	G	I	A	G	I	B	H	C	G	I	D	G	I	K			
7403	G	I	E	G	I	E	H	E	G	I	E	G	I	K			
7401	E	G	I	E	G	I	H	G	I	E	G	I	E	K			
7402	A	G	H	B	G	H	H	G	H	C	G	H	D	K			
7404	G	A	G	B	G	C	H	D	G	D	G	C	G	K			
7410	G	G	I	I	G	A	H	B	I*	I	G	C	I	K			
7413	I	I	..	G	G	A	H	B	I	I	..	G	G	K			
7420	I	I	..	G	G	A	H	B	I	I	..	G	G	K			
7430	G	G	G	G	I	I	H	A	I	I	..	K			
7442	SEE SPECIAL NOTES							H									K
7470 (a)	..	I	I	I	H	B	H	A	H	H	H	G	I	K			
(b)	..	I	H	H	H	B	H	A	H	I	I	G	I	K			
7474 (a)	I	I	G	I	A	B	H	D	C	I	G	I	I	K			
(b)	I	H	G	I	A	B	H	D	C	I	G	I	H	I	K		
7490 (a)	D	H	H	..	K	H	H	C	B	H	A	D	..	G			
(b)	G	H	H	..	K	H	H	C	B	H	D	A	..	D			
74107 (a)	I	B	A	H	C	D	H	I	G	I	H	G	I	K			
(b)	H	B	A	I	C	D	H	H	G	I	H	G	I	K			
74121	B	..	J	J	L	A	H	..	P	M	N	K			

* Touch pin to socket 1 while testing.
Where socket E is used more than once in a test, take outputs in turn to this socket (logic 'O' LED)

11. The *Truth Table* gives the successive input connections and the Decimal Output LED 5 which should be OFF in each case. Faults show up as additional LEDs OFF. It is possible for the correct output to show as well as *faulty ones* in which case the Decoder will give spurious outputs, and should be rejected.

Construction

The console is made up using 6mm and 2.5mm ply, see Fig. 3. Evostik Woodworking Adhesive is

Decimal Output	0	1	2	3	4	5	6	7	8	9
Decimal output at pins	1	2	3	4	5	6	7	9	10	11
Pin 12 (Input D)	H	H	H	H	H	H	H	I	I	
Pin 13 (Input C)	H	H	H	H	I	I	I	H	H	
Pin 14 (Input B)	H	H	I	I	H	H	I	H	H	
Pin 15 (Input A)	H	I	H	I	H	I	H	I	I	

LED which is not illuminated corresponds to the IC pin numbers

recommended, joints being held until set by a few small pins while the back cover is retained by small woodscrews. A clearance hole is cut in the top to accept the DIL holder and is soldered into a piece of 0.1 matrix Veroboard 6 x 10 holes.

16 pieces of thin insulated *stranded* wire, each 145mm long, coloured as described, are soldered in at right angles. The spreader bar (Fig. 4) made from softwood has shallow saw-cuts on each side as shown. These are given a generous coat of *Dunlop Thixofix*, and with the bar close to the Veroboard, see Fig. 3, the leads are pressed into the saw-cuts and a further coat of adhesive given. When set, the leads are captive, and the assembly is offered up and Araldited in place.

Seven pieces of stiff board are now cut and cemented to the back of the panel and the base between each pair of leads to keep them from getting tangled when they are pulled out and pushed back. Holes for the leads are drilled in the panel as shown in Fig. 5. The size of hole is chosen so that the leads are lightly nipped, in order that they remain neatly in place when stowed away.

In the prototype, pins and sockets taken from surplus 25-way connectors were used but these may not be readily available, so 1mm sockets by Doram Electronics are a good alternative. The mating plugs are rather bulky for this design, and suitable pins can be easily made from 18SWG copper wire with the nominal diameter of 1.2mm reduced by judicious stretching with the aid of a vice and pliers.

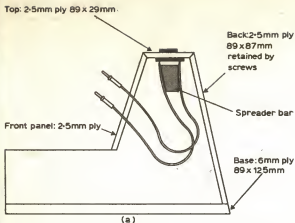

Fig. 3: End and plan view of the console. The wood used in the prototype was ply, although hardboard could be used.

Pieces 15mm long soldered to the leads by 5mm butt joints covered by short sleeves make a neat and satisfactory job. Numbering of the leads is done on the panel in two colours as in Fig. 5.

Control Board

The control board, Fig. 6, is made from 0.15in matrix plain Veroboard, 89 x 57mm. Very few extra holes had to be made, two $\frac{1}{4}$ in holes for the switches and six with a No. 55 drill for the LEDs. Before fitting the LEDs test them for uniform brightness. Sockets are spaced every other hole, except for sockets J, P, N and M which are in a compact group away from the others.

The SN7400 is soldered into a piece of Vero 0.1in matrix 7 x 7 holes. A wire from S1 passes through

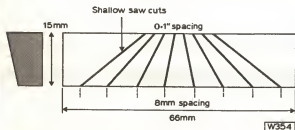

Fig. 4: Spacer bar which ensures that the leads from the IC to be tested don't get tangled and strained through continual use.

Practical Wireless, February 1977

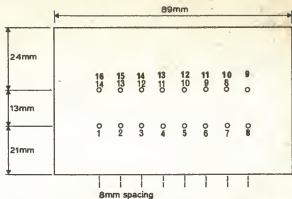
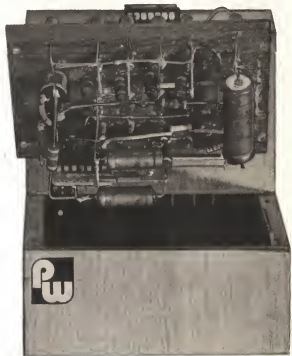

Fig. 5: Dimensioned drawing of the front panel, giving the position of the holes required to enable the leads to pass from the IC under test to the sockets.

the "14" hole to socket L, and then stiff wires taken to logic "0" (H) and "1" (I) sockets. Other components are wired in following a "right angle" pattern, so that sleeving is not necessary. Flexible leads for the power supply are led out of the bottom corner at the back, to an external bench mains unit, 5.1V stabilised or a 4.5V battery pack.



Photograph of the underside of the Prototype control board, showing how the components are soldered directly to the sockets, LEDs and switches.

Testing

When construction is complete, the reference levels may be checked. With S1 pressed, the Monitor LED should come ON and OFF with a 1:1 mark/space ratio. The logic "1" level is checked by patching the H sockets to sockets A, B, C, D when lamps 1, 2, 3, 4 should light. Voltage level should be 3.4V. The current drawn is minimal.

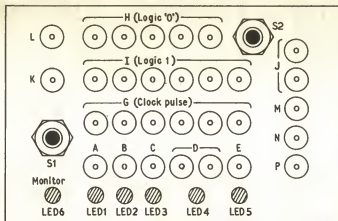
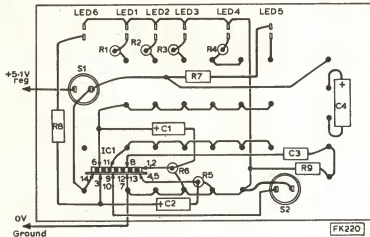

Fig. 6. Full size drawing of both sides of the control board. The sockets used are obtainable from Doram Electronics, and differ from those used in the prototype. See below for details of the IC connections.



Unmarked IC's

The procedure for unmarked ICs requires some patience, but no harm can be done unless the supply is connected the wrong way round. Analysis of TTLs reveals a pattern for these:

14 Pin				16 Pin			
Vcc	— 14	4	5	5	5	16	
Ground	— 7	11	10	12	13	8	

As a starter example, plug in a 14-pin IC, connect pin 14 to socket K, pin 7 to socket H and connect a milliammeter to sockets L and K. Make no other connections. Press S1, and if a "normal" current is drawn, the supply connections are correct. If no current is drawn, try the next pair, and so on. When supply-ground connections are correct, try:

- (1) Pin 3 in socket E (LED 5 responds to a logic "0" output.) The lamp will light for a NAND/NOR gate. If not try...
- (2) Pin 3 in socket D in case it is an OR/AND gate giving a logic "1" out with floating inputs. Again if not...
- (3) Repeat (1) and (2) using pin 6. The first gate could be faulty, or the IC is a 7404, 7410 or 7413.
- (4) Pin 8 in socket E, with the first checks unavailing, would indicate a 7430 (8 input NAND).
- (5) Finally try pin 1 in socket E—it could be a 7401 NAND gate with open circuit collector, which

works with LED 5. Pin 1 in socket D would indicate a 7402 NOR.

These five tests should reveal the gated ICs in the batch, and by making the appropriate input connections the type can be identified. The table of con-

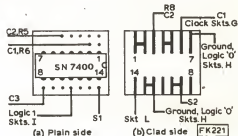

Detailed drawing of the 7400, its mounting, and connections to the board.

nections will help, but a full list covering all types is a necessity if all types are likely to be used.

Experience is an advantage in identifying the more complicated ICs, but with some practice, following the examples given, it should be possible to do many of them.