

Battery discharger

Gerard Guilhem

The circuit shown in **Figure 1** allows NiCd type LR03 (AAA) and LR6 (AA) rechargeable cells to be discharged in a controlled manner. The discharging (load) current is about 500 mA. The LED indicates the progress of the discharging process — it goes out when the battery is completely discharged. The current becomes zero at a battery voltage of about 0.6 V, which is perfectly acceptable for most NiCd cells. The 2.2-ohm resistors R2 and R3 are the components taking the battery current and turning it into heat.

The diagram in **Figure 2** closely resembles the first one. Here we suggest using an npn power transistor, T3, as the power dissipating component. The (pulsed) discharging current is determined by the value of resistor R1.

Discharging NiMH (nickel metal hydride) batteries is not a problem either, since the terminal voltage is the same as NiCd cells — the only difference is the usually higher capacity compared with NiCd cells.

The crucial parameter here is the

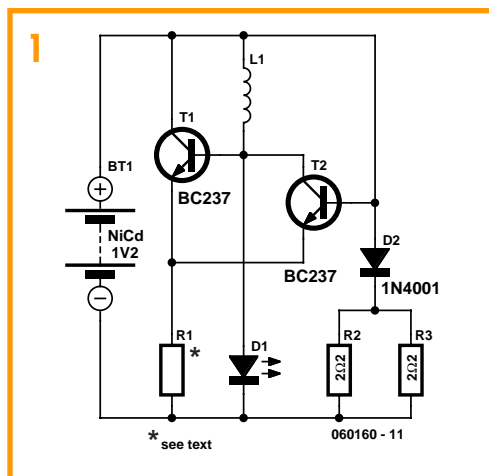

deep discharge (or 'end') voltage. Again, 0.6 V is acceptable for NiCd as well as NiMH cells. Accidental polarity reversal is a real danger, but then, only one cell is 'treated' at a time so no great losses will be suffered.

The LED goes out when the cell voltage approaches 0.9 V and that's when the battery should be disconnected. Transistors T1 and T2 of the first schematic may be just about any small-signal npn from the BCxxx series, like BC237, BC337,

BC547 and so on. Resistor R1 determines the current consumption of the circuit, as well as the current stored in choke L1 and consequently, the LED brightness. It can take a value of between 15 Ω and 47 Ω, where the lower value results in higher brightness and maximum current consumption.

The inductance of the choke is not critical and may be between 10 μH and 100 μH — you'll find that only the fre-

quency of operation will change. This will be about 200 kHz with a 20 μH choke and will vary a little due to the stray base-collector capacitance of the transistor you're using.

To prevent parasitic radiation of the circuit, it is recommended to fit a 100-nF (0.1-μF) decoupling capacitor across the battery terminals. The author employs a quadruple version of this battery discharger.

(060160-1)

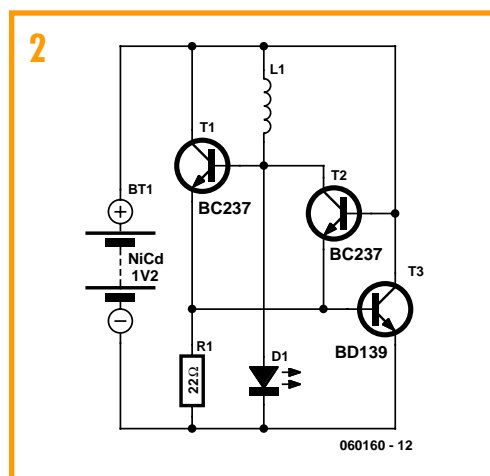

Miniature tweezers for SMDs

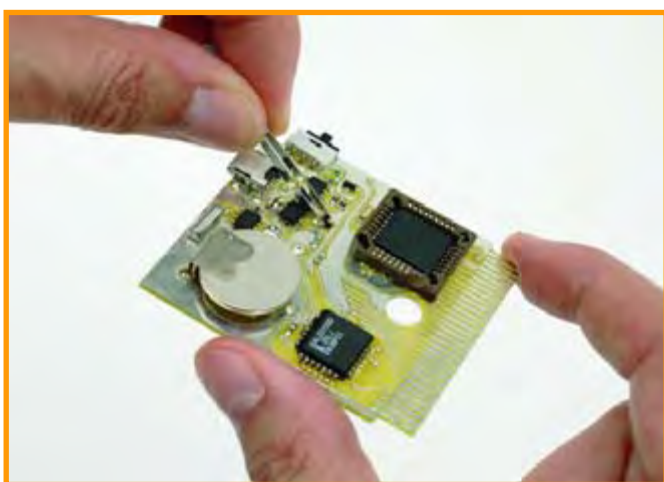

Luc Lemmens

Fitting SMD parts onto a circuit board is sure to tax your patience, eyesight and precision to a degree. In this magazine we've often described the techniques for positioning and solder-

ing of tiny parts like SMDs and will continue to share our tips and experience with you. These days, it seems you can't go round SMD parts anymore.

Although many implements and methods are available when it comes to picking up SMDs and

positioning them on a board, the humble pair of tweezers is probably one of the most frequently used tools when you're down to picking and placing SMDs manually.

Tweezers come in many shapes and sizes. However, despite their variety, they have at least one common feature: a relatively large force is required to keep the ends firmly pressed against each other. We're not talking about the physical force exerted by your fingers to close the arms, but the fact that a normal pair of tweezers will easily 'launch' a tiny part like an SMD if it is not perfectly straight in the clamps, or if you accidentally hit something while moving the part from container or reel onto the circuit board. In nearly all cases, the SMD part then becomes an easy prey for the missus' vacuum cleaner. Very annoying, and a shame to lose the part.

Fortunately, there exists a type of

tweezers that's perfect for us. Besides, it's cheap and widely available. Its small size, low spring load and flat jaws make it *the* tool for manual fitting of SMD parts. To cap it all, you may have already this perfect pair of tweezers — and here's a secret: it is one of the tools contained in the well-known Victorinox Swiss Army Knife!

If you want one, the good news is that you do not necessarily have to buy an SAK. The tweezers are also available as a spare part from hardware stores or outdoor sports shops. Still, choosing a tool for a certain job is subject to personal taste — what's perfect for you may be a disaster for someone else. Some of you may argue that the SAK mini tweezers are far too small but then the price of about £2.50 each can't be a real objection if you want to give it a try.

(060229-1)