

MODEL: 17870-0001

Product Data

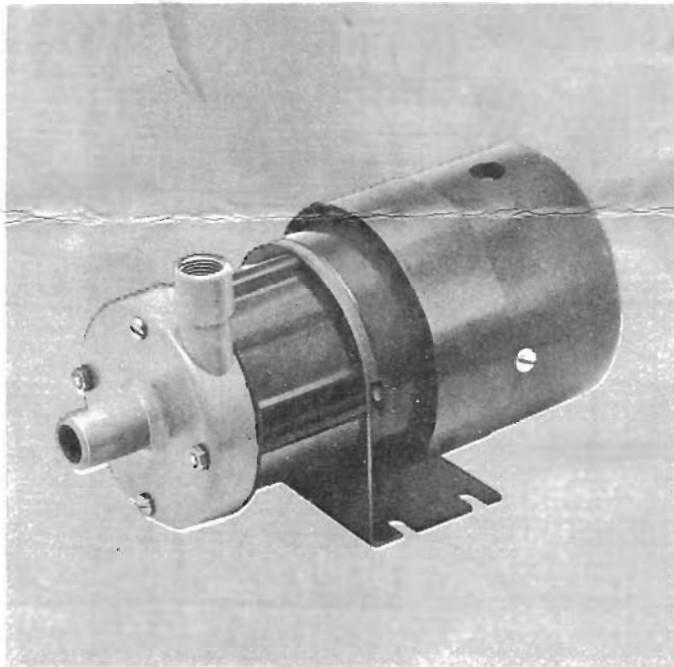

MODEL 17870-0001

DESIGN FEATURES

Pump Material:	Plastic: CPVC and Epoxy
Impeller Design:	Enclosed
Ceramic Magnet:	Chemical Resistant Coating
Suction Port Connection:	3/4" Slip-On Hose
Discharge Port Connection:	3/8" NPT & 3/4" Slip-On Hose
Maximum Temperature:	180°F (82, 2°C)
Motor:	115 V., A.C., 1/40 H.P. 3000 RPM/60 cycle T.E.F.C. thermal overload protection, Class "A" insulation. Three prong grounded plug.

MODEL 17870-0001

APPLICATION AND OPERATING INSTRUCTIONS

Pump designed for transfers, circulation, filtration and drainage. The magnetic drive centrifugal pump does not need any seal. It is a leak proof design. This all plastic pump does not have any metal part in contact with the fluid. Capable of handling photo chemicals, corrosive fluids, plating solutions, lab solutions and many others.

1. **INSTALLATION** — Pump is a *non* self-priming centrifugal design. Flooded suction installation is recommended. Rotation is clockwise (viewed from motor end).
2. **PRIMING** — Pump must be primed before starting. Do not run dry. Damage will result.
3. **CAUTION** — Use only plastic fittings in discharge port.
4. **LOCATION** — Pump inlet should be located below liquid surface. Keep suction and discharge line as free of elbows and valves as practical to obtain maximum performance.
5. **SUCTION AND DISCHARGE LINES** — Both should be supported independent of pump. Suction line should be air tight. Discharge lines should be designed with minimum number of fittings and bends to reduce head loss from friction.
6. **PRIMING**—If there is some suction lift, a flap type foot valve can be used to facilitate priming.

JABSCO PRODUCTS **ITT**

EXPLODED VIEW

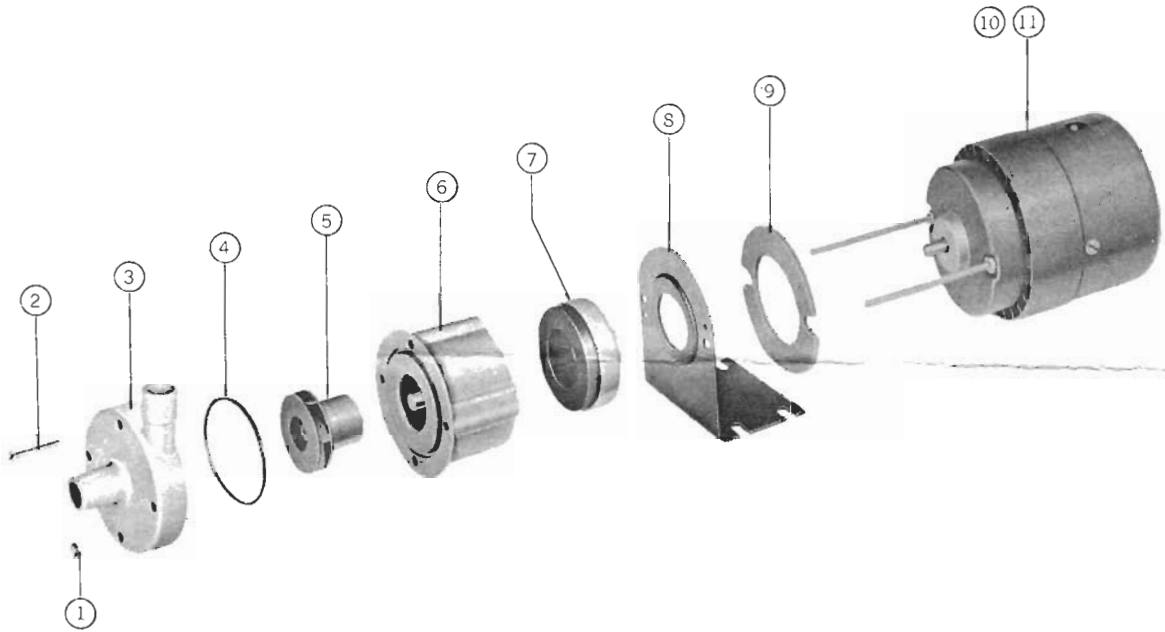

PARTS LIST

Key	DESCRIPTION	Qty. Req.	Part No.
1	Nut, Hex	4	94000-0050
2	Screw	2	91014-0050
3	Pump Body	1	17867-0000
4	"O" Ring	1	92000-0990
5	Impeller Assy.	1	17874-0009
6	Magnet Housing	1	17876-0000
7	Drive Magnet Assy.	1	17875-0000
8	Mounting Bracket	1	17864-0000
9	Spacer	1	17868-0000
10	TEFC Motor	1	93004-2430

PUMP PERFORMANCE

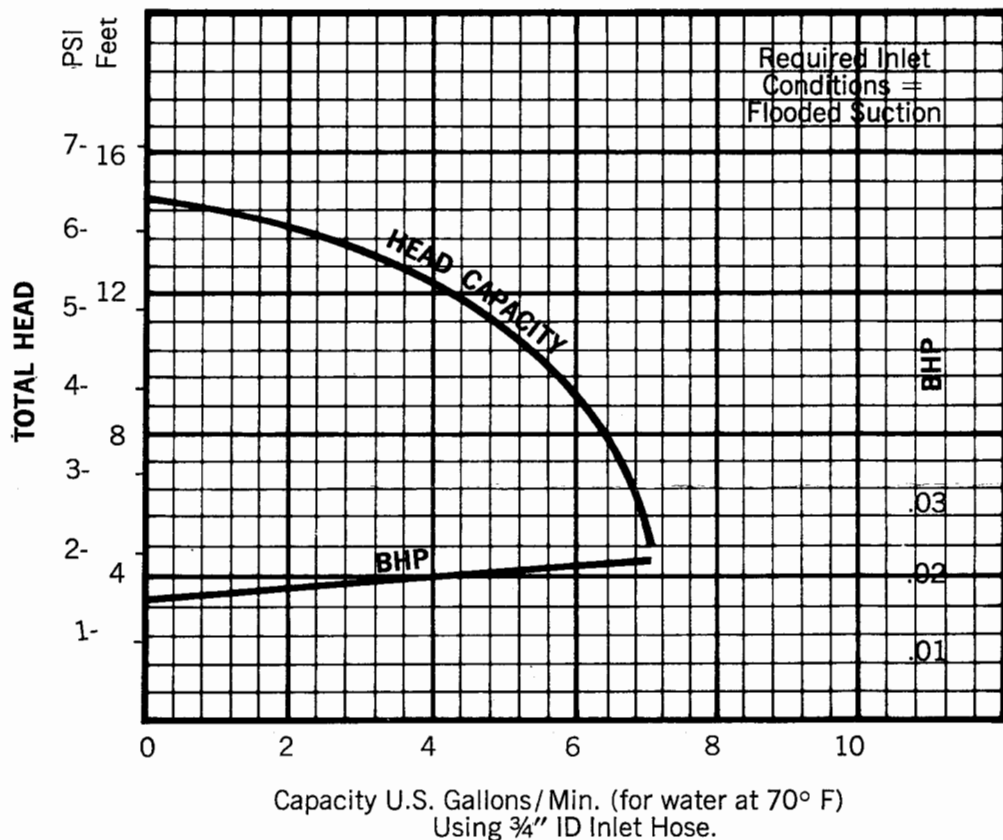

Pump Model
17870-0001

Inlet Port
3/4" Slip on Hose

Discharge Port
3/8" NPT
or 3/4" Slip on Hose

Impeller No.
17874-0009

Speed
3000 RPM

Maximum HP
1/40

Maximum Allowable Sp. Gr.
1.4 @ 14.4 Ft. HD
1.1 @ 5 Ft. HD

SERVICE INSTRUCTIONS

DISASSEMBLY

1. Loosen nuts and screws, remove body.
2. Remove impeller assembly from seal housing.
3. Remove "O" Ring from seal housing.
4. Remove seal housing from motor bracket.
5. Loosen set screw and remove drive magnet assembly from shaft; only if necessary to replace drive magnet assembly.
6. Remove bracket and spacer.

ASSEMBLY

1. Install spacer on motor.
2. Install mounting bracket on motor bearing boss.
3. Install drive magnet assembly on shaft. There should be .030 clearance between magnet drive cup boss and face of motor bearing. Secure drive magnet assembly to shaft with set screw.
4. Locate and engage magnet housing on mounting bracket. Locating pins must engage in bracket.
5. Install "O" Ring in magnet housing.
6. Install impeller assembly in magnet housing bore.
7. Install body on magnet housing. Torque nuts to 10 inch pounds. Install and tighten screws.

A FEW OF THE MANY CHEMICALS AND FLUIDS HANDLED:

PLATING SOLUTIONS
BRASS PLATING
Regular Brass Bath
High Speed Brass Bath

CADMIUM PLATING
Cyanide Bath
Fluoborate Bath

COPPER PLATING (ACID)
Copper Sulfate Baths
Copper Fluoborate

COPPER PLATING (CYANIDE)
Copper Strike Bath
Rochelle & Potassium Salt
Baths
Rochelle & Sodium Salt Baths
Barrel Copper Bath

GOLD PLATING

INDIUM CYANIDE PLATING

LEAD FLUOBORATE PLATING

NICKEL PLATING
Nickel Fluoborate Bath
All other Nickel Baths

SILVER PLATING

TIN FLUOBORATE PLATING

TIN NICKEL PLATING

ZINC PLATING
Acid Fluoborate Bath
Alkaline Zincate Bath
Acid Sulfate Bath
Cyanide Bath

OTHERS:
Alcohol Butyl
Alcohol Propyl
Boric Acid
Brine (calcium chloride)
Carbonic acid
Chlorox (Bleach)
Citric Acid

OTHERS (Cont'd):
Ferric Nitrate
Ferric Sulfate
Ferric Chloride
Freon 113-TF
Hydrochloric Acid
Jet Fuel
Kerosene
Magnesium Chloride
Magnesium Hydroxide Nitrate
Naphtha
Nickel Chloride
Nitric Acid (5-10%)
Oils (most)
Photographic Developer
Potassium Hydroxide
Phosphoric Acid
Sodium Thiosulfate
Sodium Hypochlorite
Water — Salt
Water — Fresh
Zinc Sulfate

For Other Fluids and Specific Applications
Consult Jabsco's Chemical Resistance Table

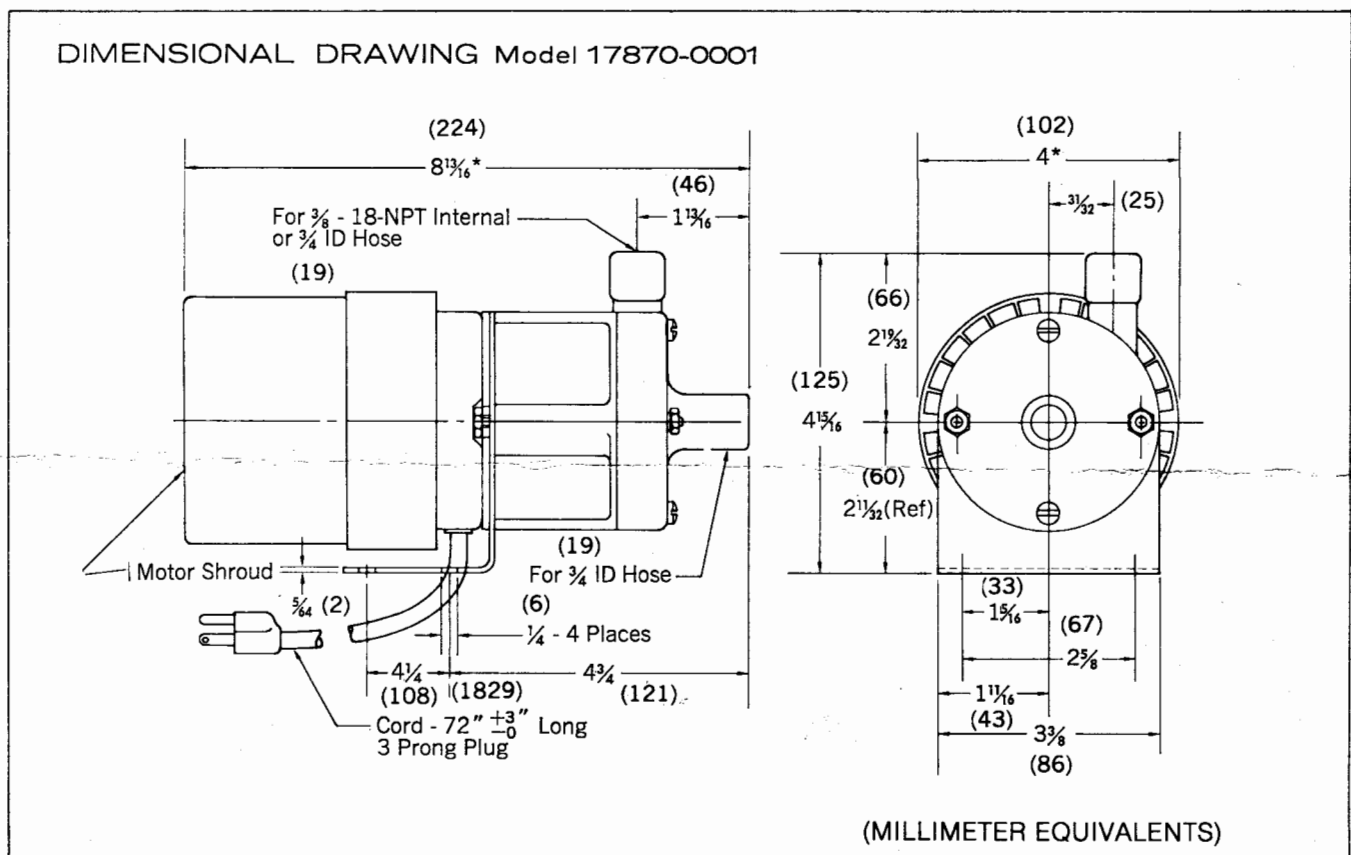

JABSCO PRODUCTS **ITT**

A Unit of International Telephone and Telegraph Corporation, 1485 Dale Way, Costa Mesa, California 92626

Telephone: (714) 545-8251