

Oscilloscope Measurements Guide

Part 2 (Conclusion)

Test procedures for sine waves, phase, Lissajous, pulses, frequency response, square waves, and dc-linearity and curve-tracer measurements

By Robert Witte

Last month, in the first installment of this article, we discussed the typical elements that make up the typical analog oscilloscope, the differences between analog and digital scopes, and the types of probes commonly used. This month, we get into actual testing procedures.

An oscilloscope produces a picture of the voltage waveform that is being measured. This allows the instrument user to think in terms of the actual waveform when making measurements. Therefore, determining zero-to-peak voltages, rms voltages and the like simply means interpreting the scope display. The displayed waveform's accuracy is subject to the instrument's finite bandwidth, internal errors and the loading effect.

Sine-Wave Measurements

Figure 9 shows a typical display of a sine wave on an oscilloscope CRT screen. The usual parameters can be determined with just a small amount of care. Peak-to-peak voltages can be first found in terms of display divisions and then be converted to volts. The peak-to-peak value of the

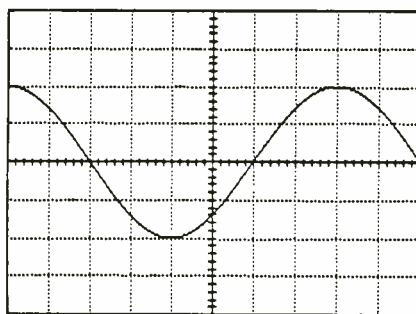

Fig. 9. Sine wave voltage measured using an oscilloscope. If vertical sensitivity is 0.5 volt/div., V_{p-p} is 2 volts and V_{0-p} is 1 volt.

sine wave in Fig. 1 is four divisions. If vertical sensitivity is set to 0.5 volt/div., the peak-to-peak voltage is $4 \times 0.5 = 2$ volts. (This value might need to be adjusted if a divider probe is used.) Zero-to-peak voltage is just two divisions, so $2 \times 0.5 = 1$ volt.

Root-mean-square (rms) voltage is not as easy to determine, at least not directly from many oscilloscopes. But the relationship between zero-to-peak and rms values for a sine wave is known: $V_{rms} = 0.707 \times V_{0-p} = 0.707 \times 1 \text{ volt} = 0.707 \text{ volt rms}$. This calculation is valid for only a sine wave, but there are conversion factors for other waveforms.

The foregoing uses the vertical

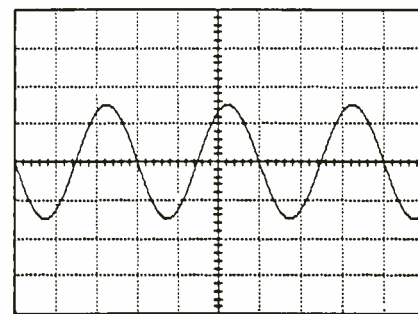

Fig. 10. Oscilloscope waveform when vertical sensitivity is 0.2 volt/div. and time base is 500 microseconds.

scale to determine voltage information. The horizontal (or time) scale can be used to determine the waveform's period. The waveform's period in Fig. 9 is eight divisions. With the horizontal axis set at 0.2 ms/div., the signal's period is $8 \times 0.2 \text{ ms} = 1.6 \text{ ms}$. Although the frequency cannot be read from the scope directly, it can be calculated by using the period waveform

$$f = 1/T$$

The waveform's frequency in the illustration equals $1/1.6 \text{ ms}$, or 625 Hz. Frequency is another value that cannot be determined directly from

(Continued on page 26)

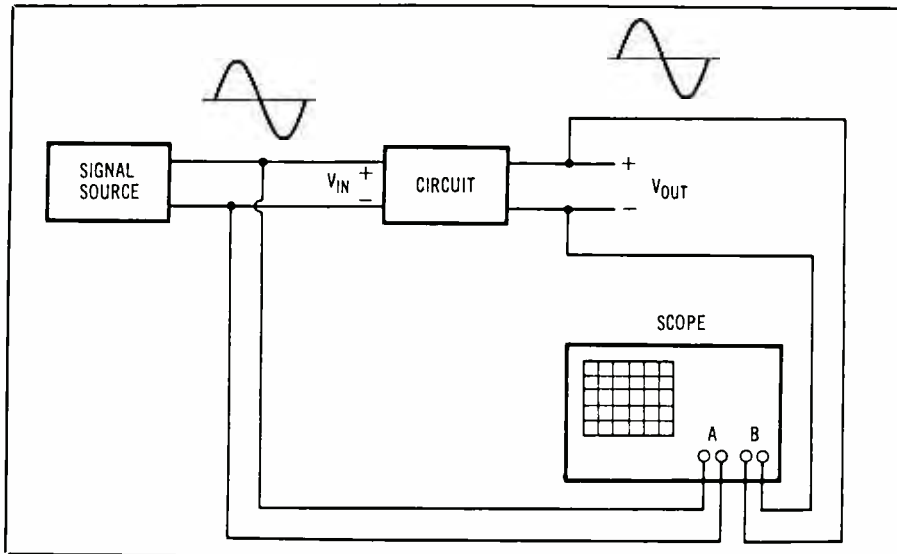

Fig. 11. Arrangement for measuring ac voltage gain of a circuit.

size is usually much smaller and more convenient. Voltmeters are also generally more accurate for amplitude measurements than oscilloscopes. A typical oscilloscope amplitude accuracy is around 3 percent, while voltmeter accuracies are typically better than 1 percent. However, the voltmeter provides no time or frequency information at all.

Voltage-Gain Measurement

It is often desirable to measure gain (or loss) of a circuit such as amplifiers, filters and attenuators. The voltage gain is defined as

$$\text{Voltage Gain} = G = V_{in}/V_{out}$$

where V_{in} and V_{out} are voltages at the input and output of a circuit, respectively. In other words, gain describes how big the output is compared to the input. V_{in} and V_{out} can be any type of voltage: dc, ac zero-to-peak, ac rms, etc., as long as both voltages are measured consistently. If output is larger than input, gain is greater than one; if output equals input, gain is exactly one; and if output is less than input, gain is less than one.

Voltage gain can be expressed in decibels (dB):

$$\begin{aligned} \text{Voltage Gain (dB)} &= G \text{ (dB)} \\ &= 20 \log (V_{in}/V_{out}) \end{aligned}$$

If output is greater than input, gain (in dB) is a positive number. If output equals input, gain is 0 dB. If output is less than input, gain in dB is a negative number. Gain and loss are opposite terms. A gain of -10 dB (output is actually smaller than input) corresponds to a 10-dB loss.

Figure 11 shows the simplest method for measuring ac voltage gain. A source is used to supply input voltage and a two-channel oscilloscope is used to measure input and output voltages. The source can be any type capable of producing a sine wave at the frequency of interest. The resulting oscilloscope display is shown in Fig. 12. Values of the two voltages are determined from the display and

the oscilloscope, but the scope gives us the information needed to calculate the value.

As an example, one can determine zero-to-peak voltage, peak-to-peak voltage, period and frequency of the waveform shown in Fig. 10 with a few simple calculations, as follows:

The waveform shown here is 1.5 divisions zero-to-peak and three divisions peak-to-peak.

$$\begin{aligned} V_{0-p} &= 1.5 \text{ div.} \times 0.2 \text{ V/div.} = 0.3 \text{ volt} \\ V_{p-p} &= 3 \text{ div.} \times 0.2 \text{ V/div.} = 0.6 \text{ volt} \end{aligned}$$

The period of the waveform is three divisions.

$$\begin{aligned} T &= 3 \text{ div.} \times 500 \mu\text{s/div.} = 1.5 \text{ ms} \\ f &= 1/T = 666.67 \text{ Hz} \end{aligned}$$

If a voltmeter and an oscilloscope

are connected to the output of a function generator, a comparison of the two measurements will highlight the advantages of each. The scope provides a complete representation of the waveform out of the function generator. Its peak-to-peak and zero-to-peak ac values are easily read and, for most waveforms, the rms value can be calculated. If there is some dc present along with the waveform, this, too, will be evident in the voltage-vs.-time display (assuming that the scope is dc coupled). The period and frequency of the waveform can also be measured.

On the other hand, the voltmeter will supply only voltage information about the waveform. Many voltmeters will read rms, but accuracy of the reading may be dependent on the type of waveform (if the meter is an average-responding type). Also, no indication is given of the actual shape of the waveform. The user may assume a given shape, but distortion due to improper circuit operation may cause the waveform to be much different.

A voltmeter is easier to use than a scope, of course. It requires less interpretation of its display, has fewer controls to adjust, and its physical

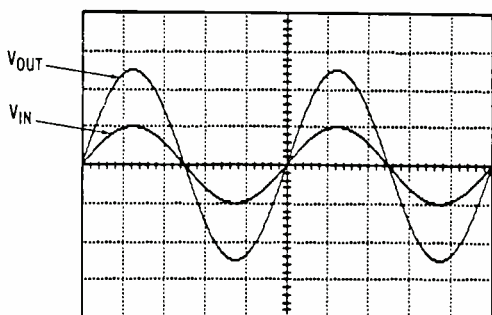

Fig. 12. Oscilloscope display for measuring gain of a circuit.

the gain is calculated. If the input signal into the circuit is not critical, then it is desirable to set the sine-wave source so that the value of V_{in} is at a convenient level (such as 1 volt) to calculate gain. Again, the ac voltage can be determined in a variety of ways, but zero-to-peak and peak-to-peak will usually be the most convenient to use.

As an example, let us determine the voltage gain for V_{in} and V_{out} shown in Fig. 12, expressing the value in dB. It shows the zero-to-peak value of $V_{in} = 1 \text{ div.} \times 1 \text{ volt/div.} = 1 \text{ volt zero-to-peak}$ and $V_{out} = 2.5 \text{ div.} \times 2 \text{ volts/div.} = 2.5 \text{ volts zero-to-peak}$. The voltage gain, $G = V_{out}/V_{in} = 2.5/1 = 2.5$.

Notice how easy the gain calculation was with V_{in} equal to 1 volt. Gain in dB, $G \text{ (dB)} = 20 \log 2.5 = 7.96 \text{ dB}$.

Phase Measurement

The waveforms shown in Fig. 12 have no phase difference between them, but this is not always the case. Many circuits introduce a phase shift between input and output. In some electronic systems, phase shift is unimportant, but many times it is a critical parameter to measure.

The setup shown in Fig. 11 can be used to measure phase shift through a circuit. If there is a non-zero phase shift through a circuit, the resulting oscilloscope display will look something like Fig. 13. (Circuit gain is 1 for simplicity.) The scope display gives the user a direct, side-by-side comparison of the two signals to determine phase difference.

First, the sine-wave period is found in terms of graticule divisions. (Recall that one complete cycle corresponds to 360 degrees.) Next, determine the phase difference in terms of graticule divisions. This can best be done by choosing a convenient spot on one waveform and counting the divisions to the same spot on the other waveform. The starting edge

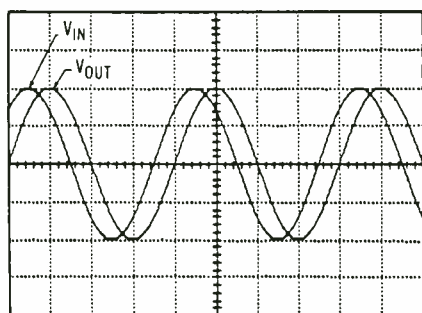

Fig. 13. Phase difference between two sine waves can be measured using time-base method.

of the sine wave (where it crosses zero) is usually a good reference point since most scope graticules have the middle of the display marked with the finest resolution. The resulting phase difference, in degrees, is:

$$\text{Phase Shift } \theta = 360 \times \frac{\text{Shift (in div.)}}{\text{Period (in div.)}}$$

Since interpreting the oscilloscope display is somewhat tedious, it is recommended that the user double check the measured value. This simply means taking another look at the display, roughly estimating the phase shift (knowing that one cycle is 360 degrees), and comparing this to the calculated answer. The two should be roughly the same.

The only problem remaining is to determine the phase shift (positive or negative). V_{out} is normally measured with respect to V_{in} , so V_{in} is the phase reference. If V_{out} is shifted to the left of V_{in} (V_{out} leads V_{in}), then V_{out} will have a positive phase relative to V_{in} . If V_{out} is shifted to the right of V_{in} (V_{out} lags V_{in}), then V_{out} will have a negative phase relative to V_{in} . Use of the terms "lead" and "lag" are less likely to be confusing than calling the phase positive or negative.

Since phase repeats on every cycle (360 degrees), the same phase relationship can be described in numerous ways. For example, if V_{out} leads V_{in} by 270 degrees, this will be the same as V_{out} lagging V_{in} by 90 degrees. Although both of these expressions are technically correct, it is recommended that phase differences be limited to ± 180 degrees. Therefore, the appropriate expression would be V_{out} lags V_{in} by 90 degrees.

Here is how to determine phase difference between V_{out} and V_{in} in Fig. 13. The period of both waveforms is four divisions, while phase shift is 0.5 division. Thus

$$\theta = 360 \times 0.5/4 = 45 \text{ degrees}$$

Since V_{out} is shifted to the right of V_{in} , V_{out} lags V_{in} by 45 degrees

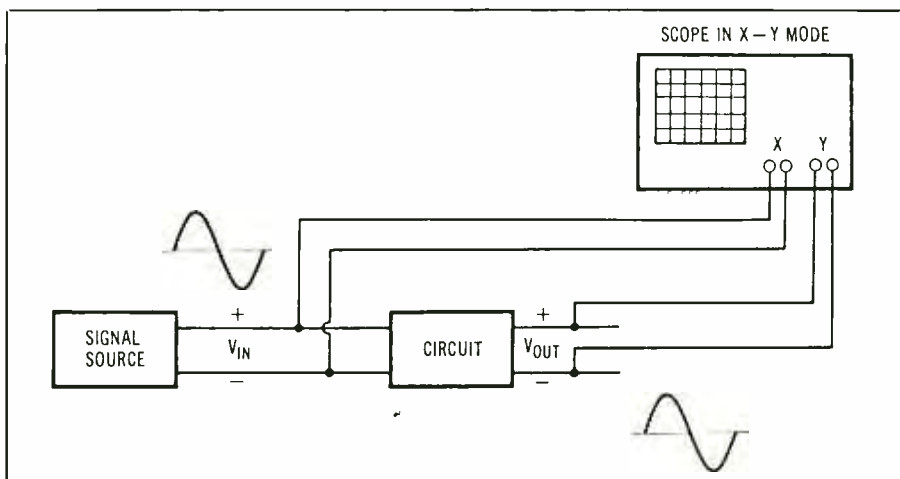

Fig. 14. The proper connection for measuring the phase difference between the input and output of a circuit.

or, equivalently, V_{in} leads V_{out} by 45 degrees.

Lissajous Method

Another method of measuring phase between two signals is called the "Lissajous method" (or Lissajous pattern). Although somewhat more complicated, this method will usually result in more accurate phase measurement. Figure 14 shows a scope connected so that phase between output and input of a circuit can be measured. The oscilloscope is configured in the X-Y mode, with one signal connected to the horizontal input and the other signal connected to the vertical input.

Figure 15 shows the elliptical shape that results from this measurement. Two values, A and B, can be read off the display and can be used to calculate the phase angle. Value A is the distance from the X axis to the point where the ellipse crosses the Y axis, and value B is the height of the ellipse, also measured from the X axis. It is important that the scope be set up with both the X and Y axes set at the 0-volt level. On most scopes, this would be accomplished by grounding both inputs and adjusting the dot on the display to be at the center of the screen. Both volts/div. controls can be adjusted to allow convenient, accurate reading of the values. The two controls do not have to be set the same, since A and B are measured along the same axis.

Two general cases must be considered. If the ellipse runs from lower-left to upper-right, the phase angle is between 0 and 90 degrees (Fig. 16). If the ellipse runs from lower-right to upper left, the angle is between 90 and 180 degrees. The angle can be calculated from the A and B values using the appropriate equation shown in Fig. 8.

Unfortunately, the sign of the angle cannot be determined using this method. If the calculated angle is 45 degrees, for example, the phase difference may be +45 or -45 degrees.

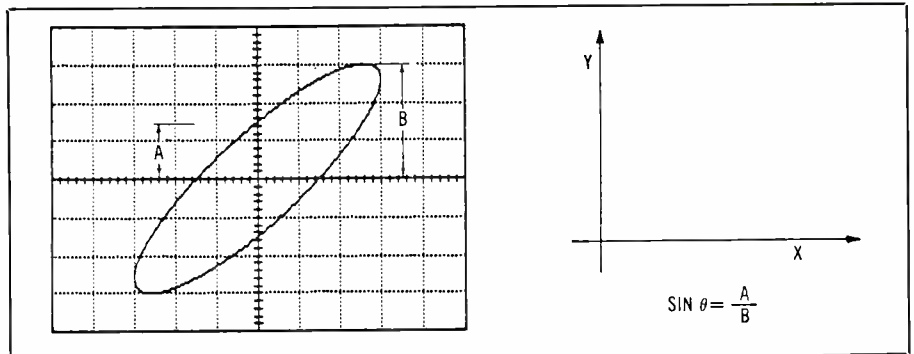

Fig. 15. Scope is in X-Y mode when using Lissajous method.

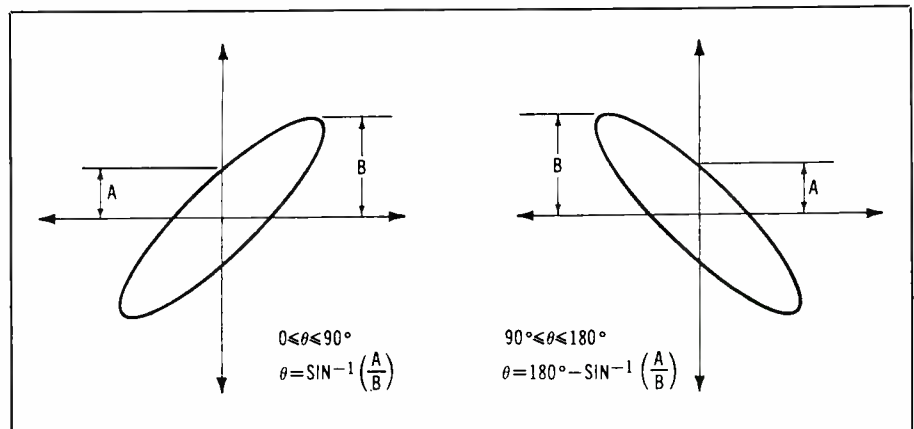

Fig. 16. Lissajous method for measuring phase has two general cases: (a) ellipse from lower-left to upper-right; (b) ellipse from upper-left to lower-right.

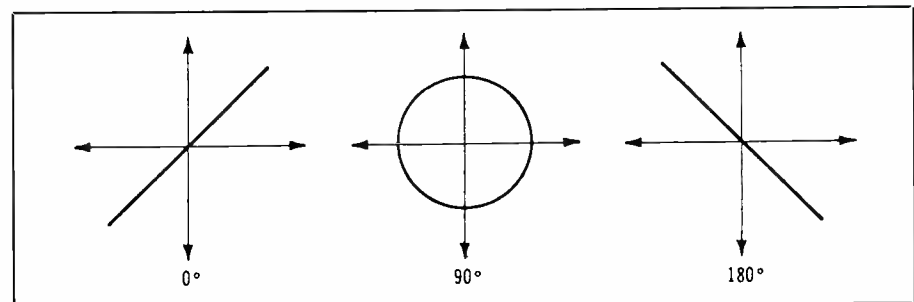

Fig. 17. Some special cases of Lissajous phase measurement.

That is, the signal on the vertical axis may be leading or lagging the signal on the horizontal axis by 45 degrees. However, the time-base method can be used to determine the sign, while using the Lissajous method for greater accuracy. A quick look using the time-base method is also a good check on the results from the Lissajous method.

Some special cases of the Lissajous display are shown in Fig. 17. Here, when the ellipse collapses into a straight line, the two waveforms are in-phase. This can also be used as a very precise indication when adjusting for zero phase between two signals. If the ellipse is a perfect circle (with both volts/div. controls set the same), the waveforms are exactly

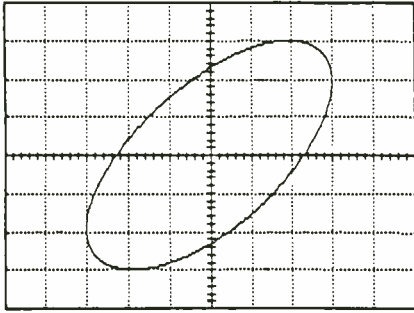

Fig. 18. Lissajous pattern for example used in text.

90 degrees apart. Again, this could be +90 or -90 degrees. If the display becomes a straight line, but in the lower-right/upper-left orientation, the two signals are exactly out-of-phase (180 degrees apart).

Here is how to determine phase difference between two signals with the Lissajous pattern shown in Fig. 18.

The ellipse is lower-left to upper-right. First find the values of A and B, which are $A = 2.3$ divisions and $B = 3$ divisions. Then calculate degrees as follows:

$$\theta = \sin^{-1}(A/B) = \sin^{-1}(2.3/3) = 50 \text{ degrees}$$

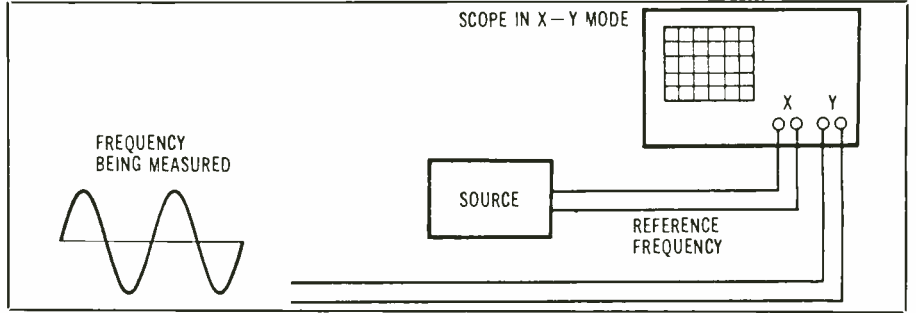

Fig. 19. Lissajous method can be used to compare frequency being measured with a known reference frequency, with oscilloscope operated in X-Y mode.

The Lissajous method can also be used to compare frequency of two sine waves. The oscilloscope, operating in X-Y mode, is connected as shown in Fig. 19. Frequency being measured is connected to the vertical axis, while reference frequency (hopefully precisely known) is connected to the horizontal axis. If the two frequencies are the same (1:1 ratio), the situation is exactly the same as the phase measurement case.

In Fig. 20a, the oscilloscope display is shown for a 1:1 frequency ratio and a 90-degree phase shift. If the phase is other than 90 degrees, the

display will not be a perfect circle, but an ellipse. Again, this case was covered under phase measurement. If the two frequencies are not exactly the same, the display will not be stable and the ellipse will contort and rotate on the display.

Other frequency ratios are also shown in Fig. 20. They may also appear warped or slanted in different ways just like the ellipse is a slanted version of a circle (for the 1:1 case). In general, the ratio of the two frequencies is determined by the number of cusps (or humps) on the top and side of the display. Consider Fig.

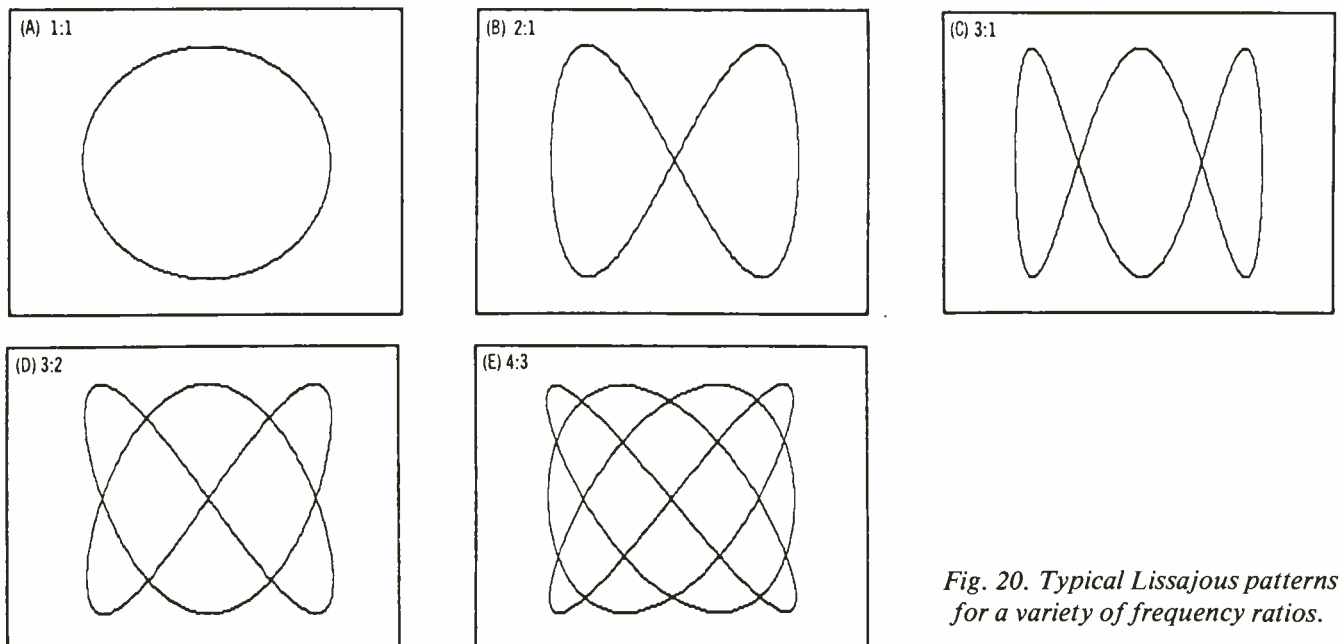

Fig. 20. Typical Lissajous patterns for a variety of frequency ratios.

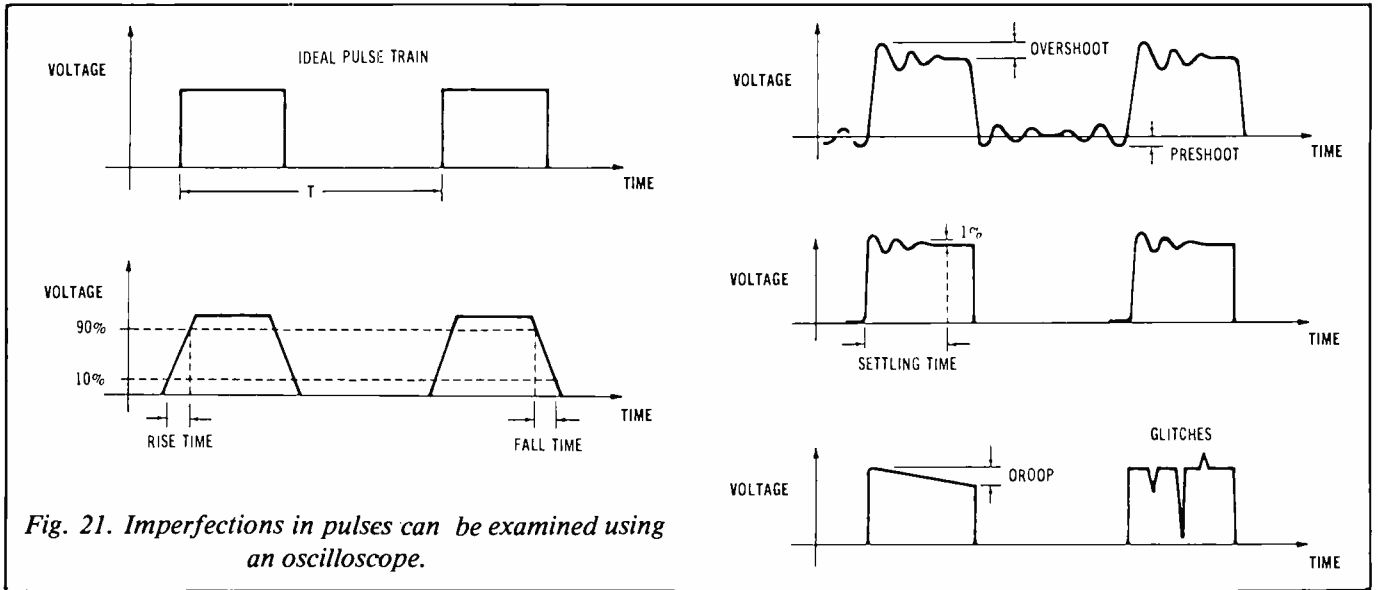

Fig. 21. Imperfections in pulses can be examined using an oscilloscope.

20b. There are two cusps across the top and only one down the side. Therefore, the frequency ratio is 2:1. In Fig. 20d, there are three cusps across the top and two down the side, resulting in a frequency ratio of 3:2.

This technique can be applied to any similar frequency ratio. The display will be stable only when the frequency ratio is exact. In general, if the frequency sources are not phase-locked together, there will be some residual phase drift between the two frequencies with a corresponding movement on the display.

This method of frequency measurement is somewhat limited since it only deals with distinct frequency ratios. It does help if a sine-wave source with variable frequency is available for use as the reference. Then the source can be adjusted so that the measured signal's frequency results in a convenient ratio.

Since this method operates on the basics of frequency ratios, the limiting factor in measurement accuracy is the reference source's frequency accuracy and stability. If the source used as the frequency reference is not

more accurate than the oscilloscope's time base, there is no advantage in using this method. Instead, the frequency should be calculated from the period of the waveform measured in the time-base mode.

Pulse Measurement

Pulse trains (and square waves) can be measured and characterized using an oscilloscope. The measurement involves basically connecting the scope to the waveform of interest, obtaining a voltage-versus-time display of the waveform and extracting

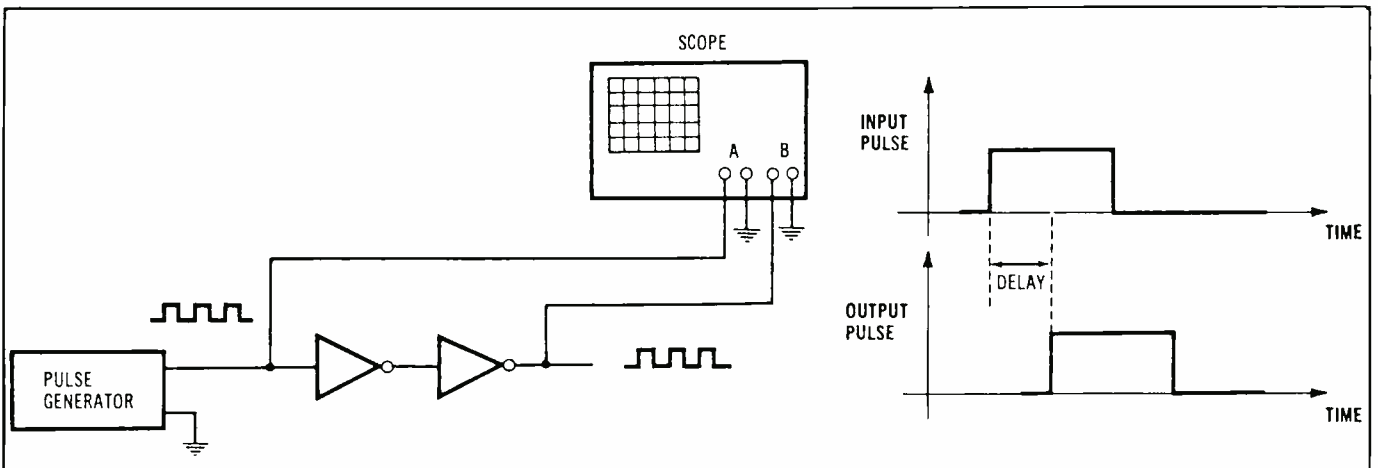

Fig. 22. An oscilloscope can be used to measure time delay between two pulses, as in input and output of a digital circuit.

the parameter of interest from the display. Oscilloscope bandwidth and rise time must be adequate so that the pulse being measured is not corrupted.

Various imperfections may exist in the pulse train (Fig. 21). Because of similarities of the pulse train and square wave, these terms for describing imperfections may also be applied to a square wave. Ideally, the pulse goes from 0 volt to V_{0-p} in zero time. However, due to circuits that cannot respond infinitely fast, rise time is finite. Rise time is usually specified to be the time it takes a waveform to go from 10 to 90 percent of V_{0-p} . Similarly, fall time is the time it takes for the waveform to go from 90 to 10 percent of V_{0-p} . Rise and fall times may or may not be the same.

The pulse may actually exceed V_{0-p} after the rising edge and then settle out. The amount that the voltage exceeds V_{0-p} is called "overshoot," and the time it takes to settle out is called "settling time." Settling time is specified when the waveform has settled to within some small percentage of V_{0-p} (often 1 percent). "Pre-shoot" is similar to overshoot, except that it occurs before the edge of the pulse.

The top of the pulse may not be perfectly flat, but have some small slope to it. The amount that the top of the pulse slopes downward is called "droop." Abrupt voltage changes in the waveform, called "glitches," are particularly common in digital circuits. Glitches can be large enough to cause a digital signal to enter the undefined region or, in more extreme cases, to change a logic state. Some circuits will tolerate a certain amount of glitching, but glitches are generally undesirable as they can cause a circuit to malfunction.

The time delay between two pulses (for example, in a digital circuit) can be measured using a two-channel scope. Figure 22 shows two logic gates (inverters) connected end-to-end and driven by a pulsed logic signal. In all digital technologies, it

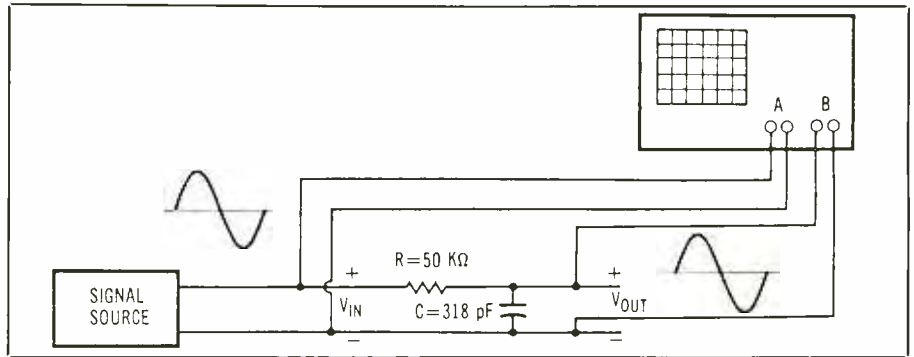

Fig. 23. Example of a frequency-response measurement.

takes a small but non-zero amount of time for the input pulse to reach the output. The oscilloscope is set up to display both input and output of the two-gate circuit. The resulting time delay between the two waveforms is found by counting the number of divisions between the rising edge of the input pulse and the rising edge of the output pulse. This is then multiplied by the time/div. setting on the scope to obtain the time difference between the pulses.

Frequency-Response Testing

Earlier, gain and phase measure-

ments were discussed as applied to a single frequency. A single-frequency sine wave was connected to the input of a circuit and the gain through the circuit as well as the phase of the output signal (relative to the input) were measured. This describes the behavior of that circuit at that particular frequency. But it is often desirable to characterize circuit performance over a wide range of frequencies. The gain and, to a lesser extent, phase measured at a range of frequencies is called the circuit's "frequency response."

The most obvious way to measure

Measured Values for RC Circuit

Frequency (Hz)	V_{in}	V_{out}	Gain	Gain (dB)
2,000	0.2	0.20	0.98	-0.17
4,000	0.2	0.19	0.93	-0.64
6,000	0.2	0.17	0.86	-1.33
8,000	0.2	0.16	0.78	-2.15
10,000	0.2	0.14	0.71	-3.01
12,000	0.2	0.13	0.64	-3.87
14,000	0.2	0.12	0.58	-4.71
16,000	0.2	0.11	0.53	-5.51
18,000	0.2	0.10	0.49	-6.27
20,000	0.2	0.09	0.45	-6.98
30,000	0.2	0.06	0.32	-9.99
40,000	0.2	0.05	0.24	-12.30
50,000	0.2	0.04	0.20	-14.14
60,000	0.2	0.03	0.16	-15.67
70,000	0.2	0.03	0.14	-16.98
80,000	0.2	0.02	0.12	-18.12
90,000	0.2	0.02	0.11	-19.13
100,000	0.2	0.02	0.10	-20.03

a circuit's frequency response is to perform multiple single-frequency gain (and phase) measurements and plot them as gain vs. frequency and phase vs. frequency. For example, Fig. 23 shows a simple low-pass RC filter being driven by a sine-wave source. The oscilloscope is connected so that it measures input and output voltages. The resulting voltage measurements at the input and output for a variety of frequencies are tabulated as shown in the Measured Values for RC Circuit table. (Note that if only gain is required, other instruments, such as a voltmeter, could be used to measure V_{in} and V_{out} .)

Gain for each frequency is calculated by dividing output voltage by input voltage at that frequency. The frequency response can then be plotted as in Fig. 24. Alternatively, frequency response can be plotted in decibels on the vertical axis and logarithmic frequency on the horizontal axis. Since the dB scale is inherently logarithmic, this results in a log-versus-log type of display.

The logarithmic scale has the effect of showing widely varying gain values on a compact plot. Notice that the frequency scale of Fig. 25 easily accommodates several decades of frequency, while the linear scale used in Fig. 17 does not.

Although the previously described point-to-point method is valid and produces accurate results, it is somewhat time consuming. To speed up the measurement process, another way to measure frequency response involves using a sweep generator. The swept sine wave of the sweep generator is connected to the input of the circuit under test. The output of the circuit is then connected to the oscilloscope's vertical (Y) channel, with the scope operated in the X-Y mode. In turn, the voltage of the sweep generator drives the horizontal (X) axis of the scope. (The generator's marker output should be connected to the scope's Z-axis input.)

As the generator sweeps in fre-

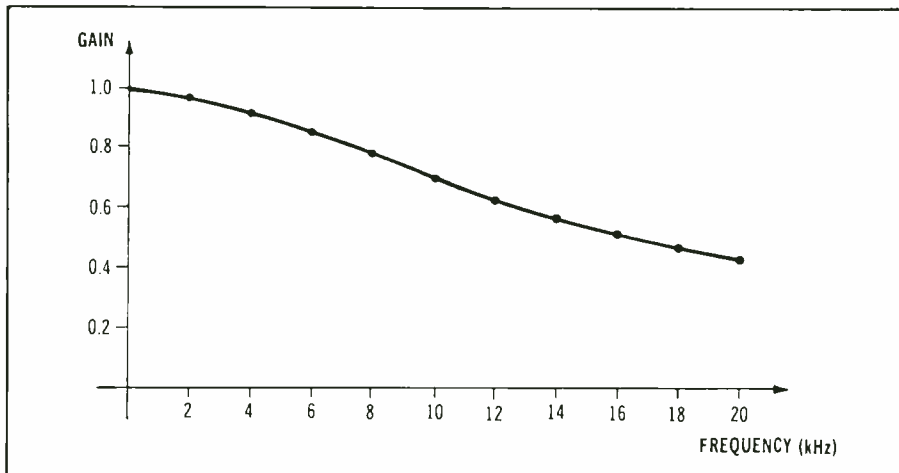

Fig. 24. The frequency response of an RC filter plotted as linear gain versus linear frequency.

quency, the sweep voltage of the generator ramps upward (in proportion to frequency), causing the output of the circuit under test to be plotted across the scope display. In this manner, the entire frequency response of the circuit is quickly displayed.

This method relies on the output of the sweep generator being con-

stant with frequency. Any deviation from flatness of the generator will cause error in the frequency response. Also, drive capability of the generator is important. The load that the circuit places on the generator will usually vary over frequency. Therefore, the generator must be relatively insensitive to these changes or an-

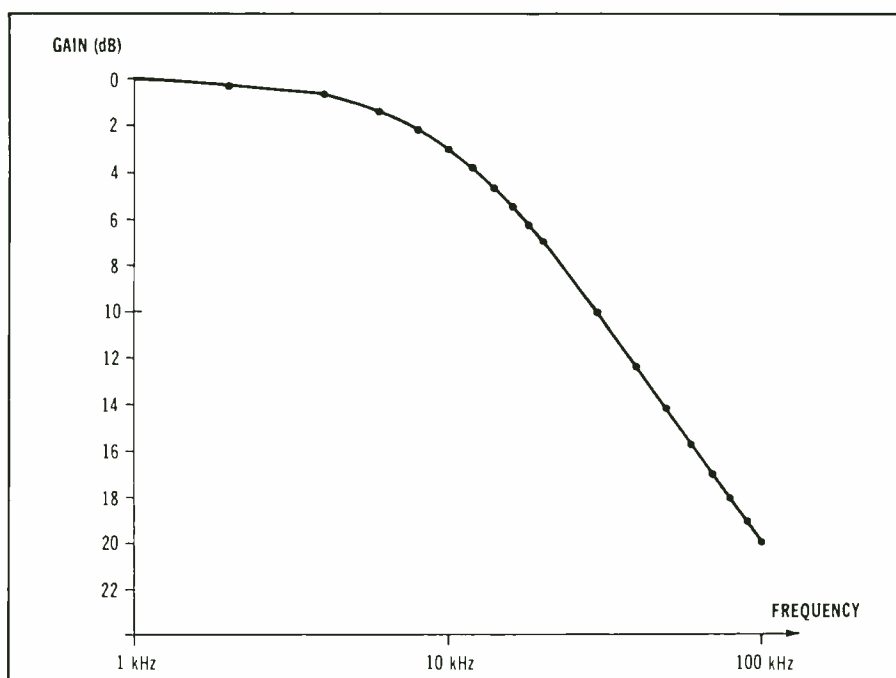

Fig. 25. Frequency response of RC filter plotted as gain in decibels (dB) versus log frequency.

other error will be introduced. For both of these reasons, it is a good idea to check (with the scope) to make sure that V_{in} is constant as the generator sweeps.

The sweep generator should not be swept too fast, since the circuit under test needs time to respond. This is particularly important in circuits with abrupt changes in gain as the frequency varies. Consequently, the sweep rate is usually set experimentally by reducing it until the frequency response no longer changes with each change in the generator's sweep rate.

The sweep generator may be swept in a linear or logarithmic manner, depending on the desired type of frequency axis. The scope's vertical axis is, of course, always linear.

It is sometimes desirable to locate a particular point on the frequency-response curve precisely with respect to frequency. Thus, many sweep generators supply a "marker" output signal that pulses when a particular frequency (or frequencies) is present at the generator output. The sweep generator will pulse the marker output, causing a change in intensity on the oscilloscope display at precisely the marker frequency. Exactly how intensity changes (whether it gets brighter or dimmer) will depend on the polarities of the marker signal and of the Z-axis input.

Square-Wave Testing

The square wave is also used to characterize frequency response of circuits. This technique is valid only for devices with flat frequency responses, such as audio amplifiers. (A fairly standard test for audio equipment is a 1-kHz square-wave test.) In addition, the circuit under test must be dc coupled.

One special case of square-wave testing is the compensation of attenuating probes. Here, a square wave is applied from a function or pulse generator to the input of the

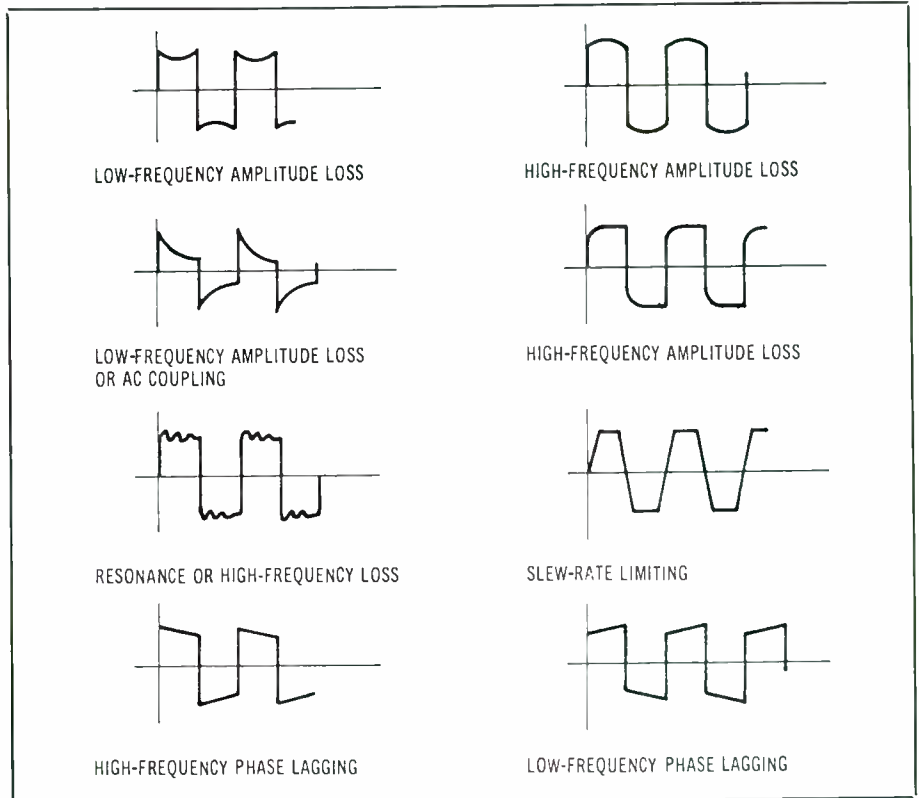

Fig. 26. Some examples of waveforms resulting from square-wave test.

circuit being tested, while the circuit's output is monitored on an oscilloscope. The square wave is very rich in harmonics, which extend out to many times its fundamental frequency, so the relative amplitude of each of these harmonics must remain unchanged in order for the output to be a square wave. If the circuit under test is an amplifier, the amplitude of each harmonic will be increased by

the amplifier's gain, but their amplitude relative to each other will remain the same. In addition, each harmonic has a particular phase relationship with the fundamental frequency that must be maintained. Otherwise, the output will not be a true square wave.

The circuit could even have a perfectly flat amplitude response but not pass a square wave correctly due to phase distortion. This type of test

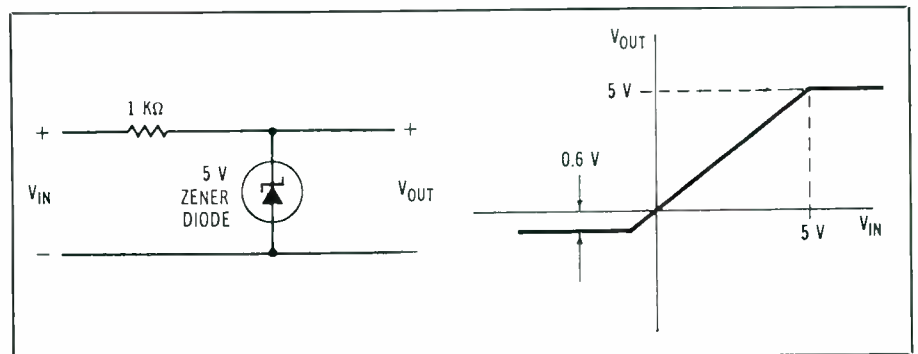

Fig. 27. Clipping circuit in (a) limits output voltage to between 0 and 5 volts. The V_{out} versus V_{in} linearity display for clipping circuit is shown in (b).

requires a high-quality waveform at the input, otherwise the output square wave will also be degraded.

Depending on the output characteristics of the generator, the circuit under test may even load the generator enough to cause distortion. It is usually a good idea, therefore, to monitor the input waveform with the second channel of the oscilloscope.

Although the square-wave test does not result in a frequency-response plot, it does test a circuit quickly, with good qualitative results. Some typical output waveforms encountered in square-wave testing and their causes are shown in Fig. 26. Phase shift at low or high frequencies can cause a tilt to one side or the other of the square wave. It is difficult to predict the effects of attenuation at either high or low frequencies as it depends greatly on the exact shape of the frequency response. However, a few typical examples are illustrated. Some circuits will exhibit noticeable degradation in the rise time of the output square wave. This is referred to as "slew-rate limiting."

Dc Linearity Measurement

It is often desirable to compare dc voltage out of a circuit with dc voltage in. This can be done using the X-Y mode of the oscilloscope. A slowly rising dc voltage is applied to the input of the circuit as well as the X axis of the scope. A convenient method of obtaining the varying dc voltage is to use a function generator's triangle wave with a very low frequency, say, 100 Hz. The output of the circuit is connected to the Y axis of the scope, resulting in the output voltage being plotted vs. the input voltage. The generator's frequency is made fast enough so that the display does not flicker too much but is made slow enough so that operation of the circuit is not affected. (Remember, a dc voltage is being simulated.)

Consider the clipping circuit

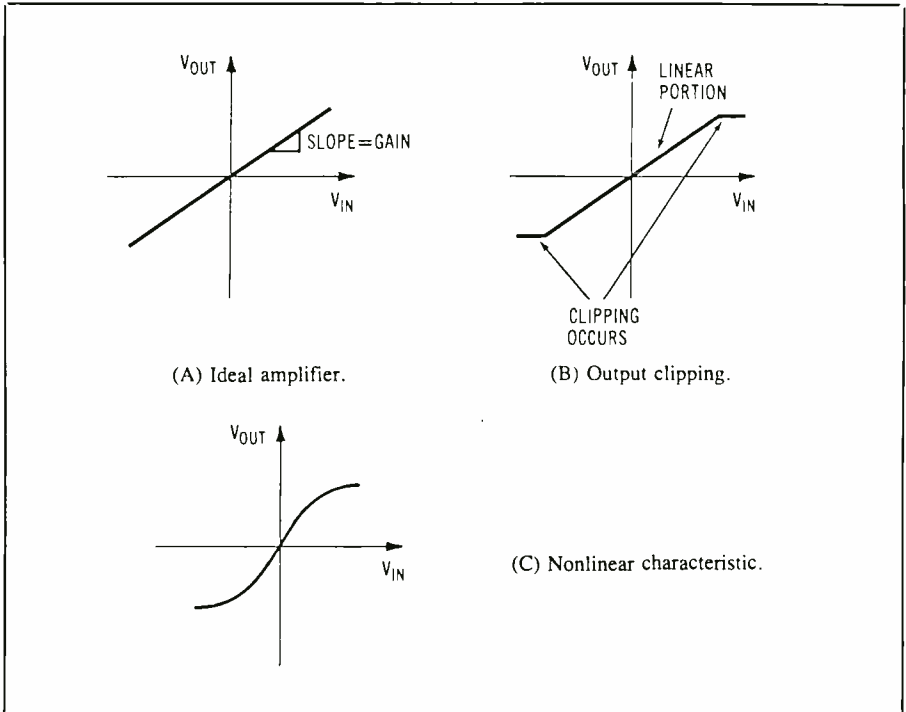

Fig. 28. The V_{out} versus V_{in} plot for an ideal amplifier is a straight line (a). In a real amplifier, imperfections like output clipping and other nonlinearities can occur, as in (b) and (c).

shown in Fig. 27a. For a V_{in} of less than 5 volts and greater than 0 volt, the zener diode acts like an open circuit and V_{out} is equal to V_{in} . When V_{in} becomes greater than 5 volts (the zener voltage), the diode turns on and V_{out} is limited to 5 volts, no matter how large V_{in} gets! If V_{in} becomes less than 0 volt, the diode turns on in the other direction and limits V_{out} to 0 volt. (Actually, it would limit the voltage to a slightly negative value, typically -0.6 volt, depending on the diode.) At any rate, the effect of the circuit is to limit the output voltage to between about 0 and 5 volts.

If a dc linearity measurement is made on the circuit using the technique described, the display would appear as shown in Fig. 27b. The sloped portion of the trace corresponds to the region where V_{out} equals V_{in} . The two flat parts of the trace are where V_{out} is limited by the clipping action of the circuit.

With an amplifier, it is usually desirable to have the output always equal the input, but amplified by some amount. Thus, the output waveform is the same as the input waveform, except that the former has a larger amplitude than the latter. For increasingly larger input voltages, the amplifier will at some point stop producing a proportionally larger output voltage. At this point, the output waveform will be clipped. Waveform peaks are flattened out at this output level.

The V_{out} -versus- V_{in} linearity plot of the amplifier can also be used to measure this phenomenon (Fig. 28a). The display is a straight line whose slope is the amplifier's gain. Ideally, the straight line would extend indefinitely. That is, the amplifier would be capable of amplifying an input voltage, no matter how large. In reality, though, the amplifier will clip at some point, usually as

the peak voltage approaches the amplifier's power-supply voltage, as shown in Fig. 28b. The straight line is still present, but it flattens out at the point of limiting. Typically, the trace does not break sharply, but instead is rounded off.

Since the V_{out} -versus- V_{in} characteristic is a straight line, this type of circuit operation is called "linear." If the plot is not a straight line, the characteristic is termed "nonlinear" (Fig. 28c). Nonlinear amplifier operation causes distortion of the output signal (usually harmonics).

Curve-Tracer Measurement

Another useful oscilloscope measurement technique is the curve-tracer circuit. This method uses the oscilloscope in the X-Y mode to display the current flowing through a component (such as a resistor or diode) versus the voltage across the component. This display is referred to as the I-V (current-voltage) characteristic of the component.

There are several ways to make this measurement. Figure 29a shows a function generator driving the curve-tracer circuit. Here, V_2 is the voltage across the device being measured and V_1 is the voltage across the resistor. By Ohm's law, V_1 will be proportional to the current through the resistor, which is also the current through the component being tested. So if V_1 could be displayed versus V_2 , the I-V characteristic of the component would be shown. If the scope has floating inputs, this can be done with no problem.

Unfortunately, most scopes have grounded inputs, which results in the situation shown in Fig. 29b. Both sides of the component under test are grounded, resulting in a short circuit across it. The situation is further compounded if the source has a grounded output. If the source is floating, the circuit in Fig. 29c can be used. Note that the circuit ends up being grounded at only one point.

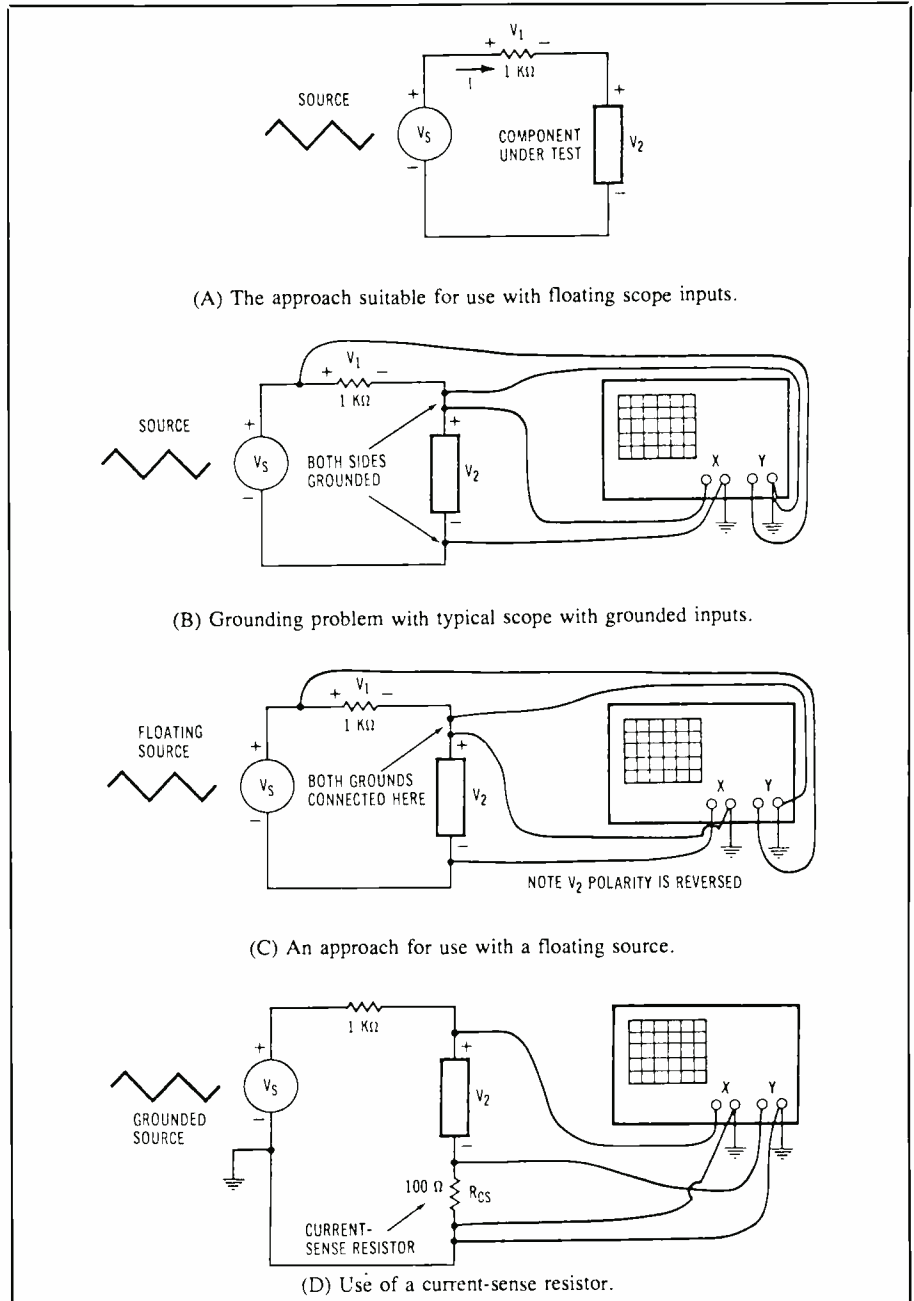

Fig. 29. Methods for displaying component I-V characteristics.

Something has changed, though! The horizontal axis of the scope will be $-V_2$ (instead of $+V_2$) due to reversal of the horizontal input leads. This can be compensated for if the scope has an "Invert Channel B" switch. Otherwise, the I-V curve will appear backwards on the display (left half of the display swapped with the right half). This may be accept-

able if you are willing to mentally make the conversion.

If both scope and source are grounded, another technique must be used. A current-sense resistor is placed in series with the component under test. The vertical input of the scope then uses the voltage across this resistor to measure current. The voltage across the current-sense re-

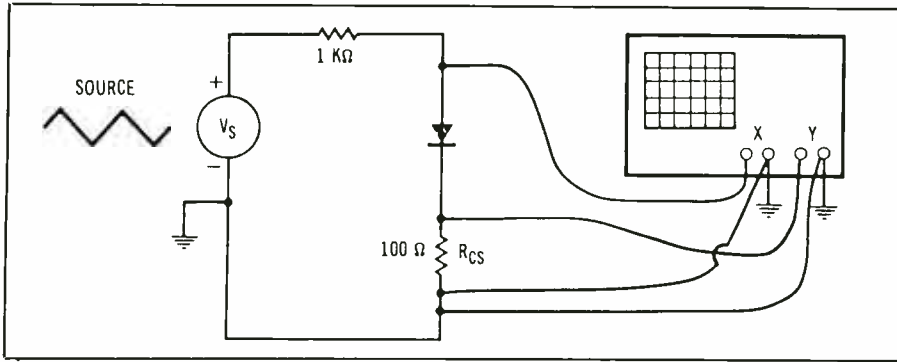

Fig. 30. Diode's I-V characteristic can be measured using curve-tracer circuit with current-sensing resistor.

sistor will introduce a small error in the measurement of V_2 , but as long as the resistor's value is kept small, the error will be acceptable. The resistor's value cannot be made too small since, for a given current being measured, voltage will increase with smaller resistance. Scope sensitivity will ultimately determine how small a current-sense resistor value can be used.

As a practical example, Fig. 30 is set up to measure the I-V characteristics of a diode, using the current-sense method. The source (usually a function generator) is set to produce a low-frequency triangle wave, although a sine wave will also work. The triangle wave acts as an automatically varying dc voltage, causing the voltage across the diode to also change. At the same time, the voltage across and current through the diode are measured. Amplitude and

frequency of the function generator can be set experimentally, but a zero-to-peak potential of 5 volts and a frequency of 30 Hz is a good starting point.

The resulting I-V characteristic of a diode is shown in Fig. 31. The horizontal scale can be determined directly from the volts/div. setting. However, the vertical scale must take into account the value of the current-sense resistor, as follows:

$$\text{Amps/div.} = (\text{V/div.})/R$$

where R is the value of the current-sense resistor.

The resulting curve is the classic behavior of the solid-state diode. For voltages greater than zero (right half of the display), current quickly increases. For voltages less than zero (left half of the display), current is essentially zero. So the diode conducts in the forward direction, but it acts like an open circuit in the reverse direction.

The scope display may actually show two separate traces instead of the single curve. One trace is drawn as the voltage increases and the other is drawn on the decreasing portion of the triangle wave. They may be slightly different due to either capacitive effects or heating of the component being tested. Reducing either the frequency or the amplitude of the triangle wave will cause the two traces to converge into a single trace.

To conclude, it is worth noting that the curve-tracer circuit can also be used to measure unknown resistors. The resulting I-V curve is shown in Fig. 32. Resistance value is determined by calculating $1/\text{slope}$ of the line, taking into account the oscilloscope's settings, as well as the value of the current-sense resistor. The current-sense resistor's value should be chosen to be at least a factor of ten smaller than the unknown resistor. **ME**

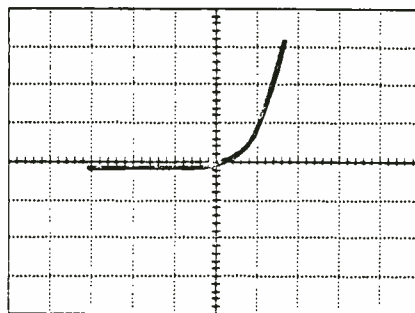

Fig. 31. The characteristic I-V curve of a solid-state diode junction.

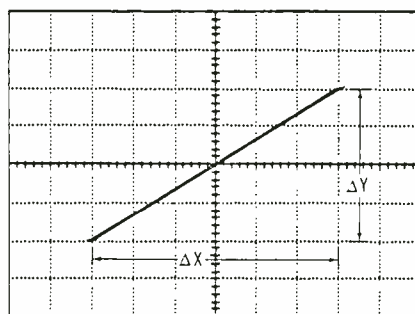

Fig. 32. The I-V curve of a resistor is a straight line with $R = 1/\text{slope}$.

RF TEST EQUIPMENT



PSA-35A Portable Spectrum Analyzer \$1965
Battery or line operated with frequency coverage from 10 - 1750 MHz and 3.7 - 4.2 GHz. Measure and document satellite communication system performance after installation or service. Troubleshoot system problems by observing output signals from LNA's, BDC's, line amplifiers and splitters, and other RF signal components. Measure block system signal balance. Identify and resolve terrestrial interference problems quickly and precisely by displaying offending signals on the PSA-35A. Numerous accessories are available.

STA-70D Test Analyzer \$1960
Displays SCPC and FM signals over a frequency range of 50 to 110 MHz, including audio demod.

STA-10D Test Analyzer \$1965
Frequency coverage 50 KHz to 10 MHz, observe and listen to audio subcarriers including SCS and data transmissions.

MSG-800 Microwave Sweep Generator \$1565
1 MHz to 800 MHz, CW, 1 KHz FM Modulation, AC & Battery.

MSG-5 Microwave Sweep Generator \$1087
3.7 to 4.2 GHz, CW, 1 KHz FM Modulation, AC & Battery.

MSG-1750A Microwave Sweep Generator \$1275
950 to 1750 MHz, CW, 1 KHz FM Modulation, AC & Battery.

MSG-2000A Microwave Sweep Generator \$1282
1000 to 2000 MHz, CW, 1 KHz FM Modulation, AC & Battery.

Other Sweep Generator frequency ranges available, call with your requirements.

MTG-3600 Microwave Tracking Generator \$1865
Turns your HP 8566 in to a network analyzer with scalar frequency response. (Tracking Generators for other spectrum analyzers available, inquire.)

AVCOM 500 SOUTHLAKE BOULEVARD
RICHMOND, VIRGINIA 23236
TELEPHONE 804-794-2500 TELEX 701-545 FAX 804-794-8284

CIRCLE 28 ON FREE INFORMATION CARD