

INTRODUCTION

A high quality, noise free, wireless FM transmitter/receiver may be made using the LM566 VCO and LM565 PLL Detector. The LM566 VCO is used to convert the program material into FM format, which is then transformer coupled to standard power lines. At the receiver end the material is detected from the power lines and demodulated by the LM565.

The important difference between this carrier system and others is its excellent quality and freedom from noise. Whereas the ordinary wireless intercom uses an AM carrier and exhibits a poor signal-to-noise ratio (S/N), the system described here uses an FM carrier for inherent freedom from noise and a PLL detection system for additional noise rejection.

The complete system is suitable for high-quality transmission of speech or music, and will operate from any AC outlet anywhere on a one-acre homesite. Frequency response is 20–20,000 Hz and THD is under 1/2% for speech and music program material.

Transmission distance along a power line is at least adequate to include all outlets in and around a suburban home and yard. Whereas many carrier systems operate satisfactorily only when transmitter and receiver are plugged into the same side of the 120–240/V power service line, this system operates equally well with the receiver on either side of the line.

The transmitter is plugged into the AC line at a radio or stereo system source. The signal for the transmitter is ideally taken from the MONITOR or TAPE OUT connectors provided on component system Hi-Fi receivers. If these outputs are not available, the signal could be taken from the main or extra speaker terminals, although the remote volume would then be under control of the local gain control. The carrier system receiver need only be plugged into the AC line at the remote listening location. The design includes a 2.5W power amplifier to drive a speaker directly.

TRANSMITTER

Two input terminals are provided so that both LEFT and RIGHT signals of a stereo set may be combined for mono transmission to a single remote speaker if desired.

The input signal level is adjustable by R_1 to prevent over-modulation of the carrier. Adding C_2 across each input resistor R_7 and R_8 improves the frequency response to 20 kHz as shown in Figure 5. Although casual listening does not demand such performance, it could be desired in some circumstances.

The VCO free-running frequency, or carrier frequency f_c , determined by R_4 and C_4 is set at 200 kHz which is high enough to be effectively coupled to the AC line. VCO sensitivity under the selected bias conditions with $V_S = 12V$ is about $\pm 0.66 f_c/V$. For minimum distortion, the deviation should be limited to $\pm 10\%$; thus maximum input at pin #5

of the VCO is $\pm 0.15V$ peak. A reduction due to the summing network brings the required input to about 0.2V rms for $\pm 10\%$ modulation of f_c , based on nominal output levels from stereo receivers. Input potentiometer R_1 is provided to set the required level. The output at pin #3 of the LM566, being a frequency modulated square wave of approximately 6V pk-pk amplitude, is amplified by a single transistor Q_1 and coupled to the AC line via the tuned transformer T_1 . Because T_1 is tuned to f_c , it appears as a high impedance collector load, so Q_1 need not have additional current limiting. The collector signal may be as much as 40–50V pk-pk. Coupling capacitor C_8 isolates the transformer from the line at 60 Hz.

A Voltage regulator provides necessary supply rejection for the VCO. The power transformer is sized for peak secondary voltage somewhat below the regulator breakdown voltage spec (35V) with a 125V line.

RECEIVER

The receiver amplifies, limits, and demodulates the received FM signal in the presence of line transient interference sometimes as high as several hundred volts peak. In addition, it provides audio mute in the absence of carrier and 2.5W output to a speaker.

The carrier signal is capacitively coupled from the line to the tuned transformer T_1 . Loaded Q of the secondary tank T_1C_2 is decreased by shunt resistor R_1 to enable acceptance of the $\pm 10\%$ modulated carrier, and to prevent excessive tank circuit ringing on noise spikes. The secondary of T_1 is tapped to match the base input impedance of Q_{1A} . Recovered carrier at the secondary of T_1 may be anywhere from 0.2 to 45V p-p; the base of Q_{1A} may see pk-to-pk signal levels of from 12 mV to 2.6V.

Q_{1A} – Q_{1D} operates as a two-stage limiter amplifier whose output is a symmetrical square wave of about 7V pk-pk with rise and fall times of 100 ns.

The output of the limiting amplifier is applied directly to the mute peak detector, but is reduced to 1V pk-pk for driving the PLL detector.

The PLL detector operates as a narrow band tracking filter which tracks the input signal and provides a low-distortion demodulated audio output with high S/N. The oscillator within the PLL is set to free-run at or near the carrier frequency of 200 kHz. The free-run frequency is $f_o \approx 1/(3.7 R_{16}C_{13})$. Since the PLL will lock to a carrier near its free-run frequency, an adjustment of R_{16} is not strictly necessary; R_{16} could be fixed at 4700 or 5100 Ω . Actually, the PLL with the indicated value of C_{11} can lock on a carrier within about ± 40 kHz of its center frequency. However, rejection of impulse noise in difficult circumstances can be maximized by carefully adjusting f_o to the carrier frequency f_c . Adding

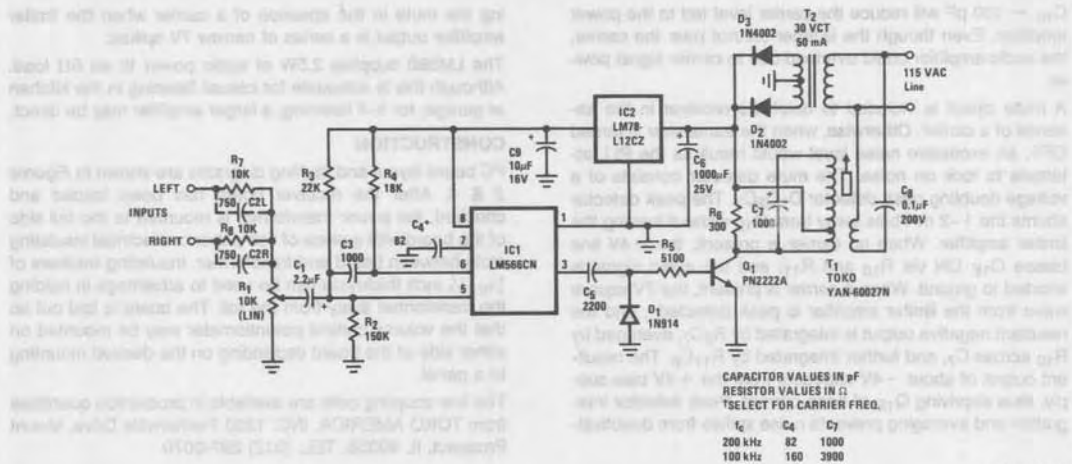

FIGURE 1. Carrier System Transmitter

TL/H/7442-1

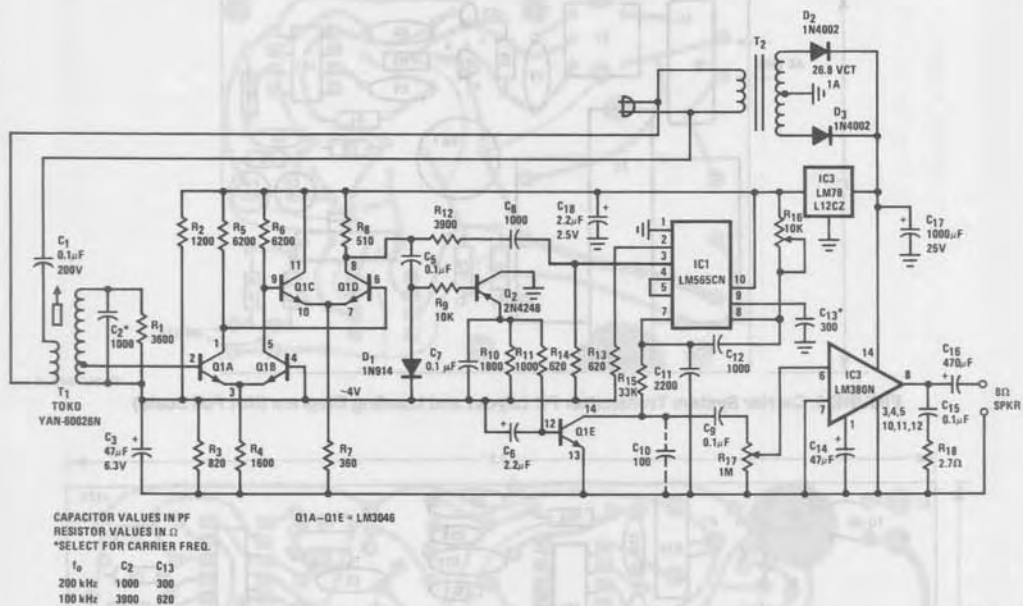

FIGURE 2. Carrier System Receiver

TL/H/7442-2

$C_{10} = 100 \text{ pF}$ will reduce the carrier level fed to the power amplifier. Even though the listener cannot hear the carrier, the audio amplifier could overload due to carrier signal power.

A mute circuit is included to quiet the receiver in the absence of a carrier. Otherwise, when the transmitter is turned OFF, an excessive noise level would result as the PLL attempts to lock on noise. The mute detector consists of a voltage doubling peak detector $D_1Q_2C_7$. The peak detector shunts the 1–2 mA bias away from Q_{1E} without loading the limiter amplifier. When no carrier is present, the +4V line biases Q_{1E} ON via R_{10} and R_{11} ; and the audio signal is shorted to ground. When a carrier is present, the 7V square wave from the limiter amplifier is peak detected*, and the resultant negative output is integrated by R_9C_7 , averaged by R_{10} across C_7 , and further integrated by $R_{11}C_6$. The resultant output of about -4V subtracts from the +4V bias supply, thus depriving Q_{1E} of base current. Peak detector integration and averaging prevents noise spikes from deactivat-

ing the mute in the absence of a carrier when the limiter amplifier output is a series of narrow 7V spikes.

The LM380 supplies 2.5W of audio power to an 8 Ω load. Although this is adequate for casual listening in the kitchen or garage, for hi-fi listening, a larger amplifier may be direct.

CONSTRUCTION

PC board layout and stuffing diagrams are shown in *Figures 3 & 4*. After the receiver board has been loaded and checked, the power transformer is mounted to the foil side of the board with a piece of fish-paper or electrical insulating cloth between board and transformer. Insulating washers of 1/16–1/4 inch thickness can be used to advantage in holding the transformer away from the foil. The board is laid out so that the volume control potentiometer may be mounted on either side of the board depending on the desired mounting to a panel.

The line coupling coils are available in production quantities from TOKO AMERICA, INC. 1250 Feehanville Drive, Mount Prospect, IL 60056. TEL: (312) 297-0070

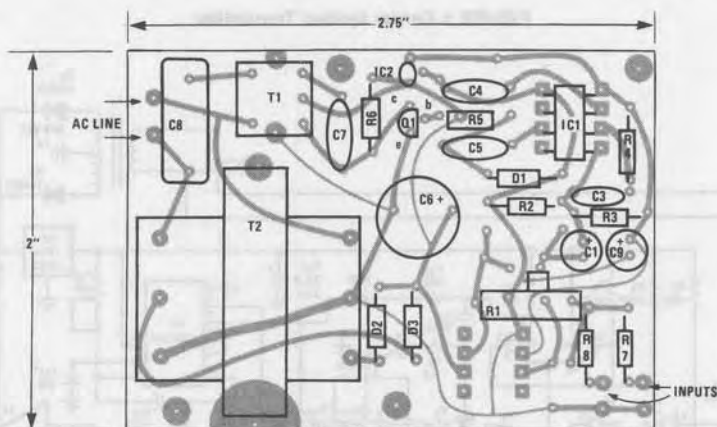

TL/H/7442-3

FIGURE 3. Carrier System Transmitter PC Layout and Loading Diagram (Not Full Scale)

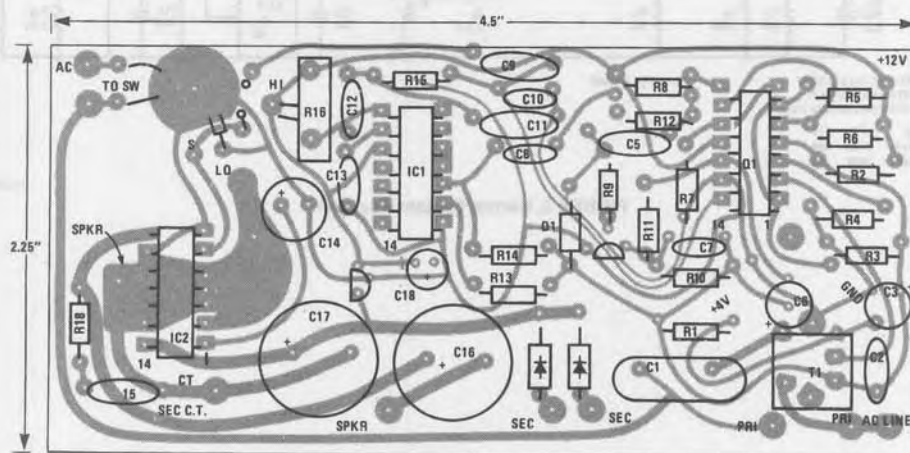

TL/H/7442-4

FIGURE 4. Carrier System Receiver PC Layout and Loading Diagram (Not Full Scale)

ADJUSTMENT

Adjustments are few and extremely simple. Transmitter carrier frequency f_c is fixed near 200 kHz by R_4 and C_4 ; the exact frequency is unimportant. T_1 for both transmitter and receiver are tuned for maximum coupling to and from the AC line. Plug in both receiver and transmitter; no carrier modulation is necessary. Insure that both units are operative. Observe or measure with an AC VTVM the waveform at T_1 secondary in the receiver. Tune T_1 of the transmitter for maximum observed signal amplitude. Then tune T_1 of the receiver for a further maximum. Repeat on the transmitter, then the receiver. Tuning is now complete for the line coupling transformers and should not have to be repeated for either. If the receiver is located some distance from the transmitter in use, or on the opposite side of the 110–220V service line, a re-adjustment of the receiver T_1 may be made to maximize rejection of SCR dimmer noise. The receiver PLL free-running frequency is adjusted by R_{16} . Set R_{16} near the center of its range. Rotate slowly in either direction until the PLL loses lock (evidenced by a sharp increase in noise and a distorted output). Note the position and then repeat, rotating in the other direction. Note the new position and then center R_{16} between the two noted positions. A fine adjustment may be made for minimum noise with an SCR dimmer in operation. The final adjustment is for modulation amplitude at the transmitter. Connect the audio signal to the transmitter input and adjust the input potentiometer R_1 for a signal maximum of about 0.1V rms at the input to the LM566. Adjustment is now complete for both transmitter and receiver and need not be repeated.

A STEREO SYSTEM

If full stereo or the two rear channels of a quadraphonic system are to be transmitted, both transmitter and receiver must be duplicated with differing carriers. Omit R_8 and include R_7 & C_2 on the transmitter if desired. Carriers could be set to 100 and 200 kHz for the two channels. Actually, they need only be set a distance of 40 kHz apart.

PERFORMANCE

Overall S/N is about 65 dB. Distortion is below about $1/4\%$ at low frequencies, and in actual program material it should not exceed $1/2\%$ as very little signal power occurs in music above about 1 kHz.

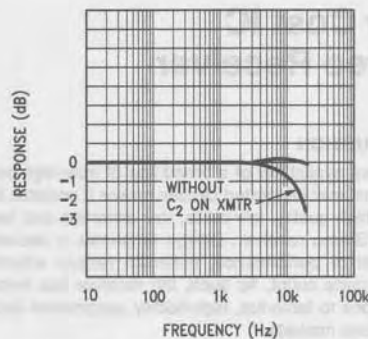

TL/H/7442-5

FIGURE 5. Overall System Performance

Transmitter Input to Input of Receiver Power Amplifier

The 2.5W audio amplifier provides an adequate sound level for casual listening. The LM380 has a fixed gain of 50. Therefore for a 2.5W max output, the input must be 89 mV. This is slightly less than the $\pm 10\%$ deviation level so we are within design requirements. Average program level would run a good 10 dB below this level at 28 mV input.

Noise rejection is more than adequate to suppress line noise due to fluorescent lamps and normal line transients. Appliance motors on the same side of the 110–220V line may produce some noise. Even SCR dimmers produce only a background of impulse noise depending upon the relative location of receiver and SCR. Otherwise, performance is noise-free anywhere in the home. Satisfactory operation was observed in a factory building so long as transmitter and receiver were connected to the same phase of the three-phase service line.

APPLICATIONS

Additional applications other than home music systems are possible. Intercoms are one possibility, with a separate transmitter and receiver located at each station. A microphone can serve as the source material and the system can act as a monitor for a nursery room. Background music may be added to existing buildings without the expense of running new wiring.