

# 8

## Telephone Repeater

This is a project which, although of general use around the house, is especially useful to have in a workshop. It is a device which will pick up the sound of a telephone ringing and relay it to some remote part of a house or to an outbuilding. This avoids the telephone call being missed because one happens to be well away from the telephone, or in a fairly noisy environment. Since many workshops are situated in outbuildings and tend to have fairly high ambient noise levels, a unit of this type is especially useful.

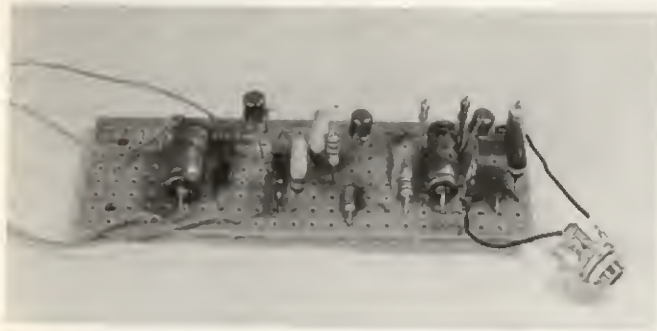

Figure 8.1  
Telephone repeater

The unit may also be of great benefit to someone who is hard of hearing, and could easily not hear the sound of a telephone ringing.

At first sight it might seem to be a better idea to simply connect a tone generator or bell direct to the telephone, rather than go to the bother of using a microphone to pick up the sound of the bell and feed an amplifier and speaker combination. Indeed, this is the case, but it must be borne in mind that it is an offence to make any unauthorised

connection to a Post Office telephone, and so the system used here must be adopted.

One slight advantage of this system is that it is convenient to use and set up due to the fact that there is no need to make a direct connection to the telephone. Also, the unit can be used to simultaneously monitor a doorbell and a telephone provided the two are situated reasonably close together.

### The circuit

The complete circuit diagram of the Telephone Repeater appears in Fig. 8.2. Basically this consists of a high gain amplifier which drives a loudspeaker. However, the unit is designed to have only a very low

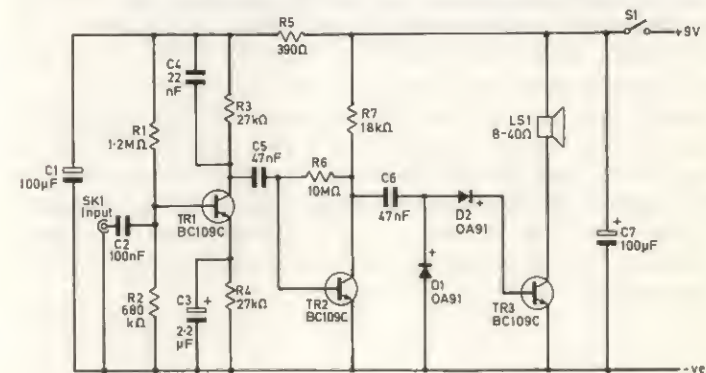

Figure 8.2  
Circuit of the telephone repeater

quiescent current consumption so that it may be run economically from batteries, despite the fact that in practice it is likely to be left switched on for quite long periods.

TR1 is the active device employed in the preamplifier stage and this transistor is used in the common emitter mode. Base biasing is provided by R1 and R2 while R4 and C3 are the emitter bias resistor and bypass capacitor respectively. R3 is the collector load for TR1. This stage operates at a low collector current of only about  $100\mu\text{A}$ , and this is done in order to provide a low noise level and to minimise battery drain. C4 is an r.f. filter capacitor which is needed in order to prevent problems due to radio interference and breakthrough. C2 provides d.c. blocking at the input.

The output from TR1 is fed to a second common emitter amplifier via C5. TR2 is used as the basis of the second amplifier stage, and R7 acts as its collector load and R6 as its bias resistor. This stage operates at a slightly higher collector current than TR1, the actual operating current being something in the region of  $500\mu\text{A}$ . This is necessary to produce higher gain and a greater output drive capability.

In order to provide a low quiescent current a class B output stage is obviously called for as the high standby current of a class A stage makes it totally unsuitable. A normal complementary output stage would be the obvious type to use, but a more simple method can be used. High fidelity amplification is not needed here as the purpose of the unit is simply to provide an audio signal of some kind. Therefore a simple single transistor class B output stage may be used, and the fact that the signal from the loudspeaker will be rectified and greatly distorted is of no consequence in this instance.

The output from TR2 is fed to a rectifier circuit by C6, and the positive going pulses produced by D1 and D2 are used to switch on TR1 and produce pulses of current in its collector circuit. These are applied to the loudspeaker and an audio output signal is produced.

The supply lines need to be well decoupled and this function is carried out by C1, R5 and C7. S1 is the on/off switch. Although in theory no current flows through the output transistor under quiescent conditions, in practice a small current may flow here due to noise and stray pick up by the microphone causing TR3 to be turned on to some extent. However, the total quiescent current consumption of the unit is typically less than  $1\text{mA}$  from a  $9\text{V}$  supply.

## Construction

All the small components are accommodated on a small  $0.15\text{in}$  pitch stripboard panel and are positioned as detailed in Fig. 8.3. Begin by cutting out a board having 8 copper strips by 24 holes and then drill the two  $3.2\text{mm}$  diameter mounting holes and make the ten breaks in the copper strips. The components are then soldered into position.

S1, SK1 and the loudspeaker are all mounted on the front panel at any convenient points which provide a reasonably neat and tidy appearance. SK1 can conveniently be a  $3.5\text{mm}$  jack socket, but any preferred type (DIN, phono, etc.), should also be suitable. Loudspeaker mounting has been described in earlier projects, and will not be repeated here.

Once the components for front panel mounting have been installed in the case the point to point wiring can be completed and then the component panel is mounted inside the case using M3 or 6BA mounting screws and nuts. Although the input of the unit is very sensitive it is not

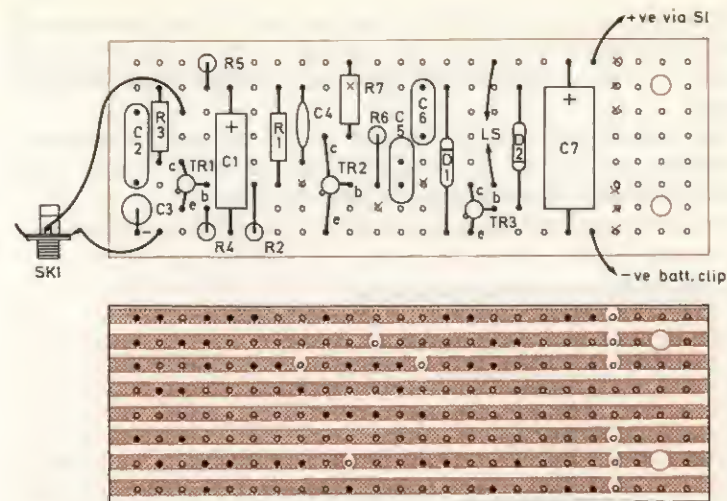

Figure 8.3  
Strip board layout

necessary to use a screened cable to connect SK1 to the component panel.

## Using the unit

A low impedance dynamic microphone can be used with the unit, and an inexpensive type (such as those used with cheaper cassette recorders) is perfectly adequate. Some of these have two plugs, a  $3.5\text{mm}$  one and a  $2.5\text{mm}$  one. Both will need to be cut off so that the microphone can be connected to an extension cable. The wiring to the  $2.5\text{mm}$  jack plug, if fitted, is concerned with the remote control switch on the microphone and this wiring may be ignored. The extension cable can be several metres long if necessary, but it must be made from screened lead. The outer braiding connects to the negative supply rail of the repeater circuit and the inner connector goes to C2.

The circuit is very sensitive and it should be possible to obtain good results even with the microphone a metre or two away from the telephone.

Low, medium and high impedance loudspeakers seem to work quite well as the microphone for this unit, but these provide lower sensitivity than a proper microphone, particularly low impedance loudspeakers. However, they provide a perfectly adequate output level provided they

are placed on or very close to the telephone, and if a low impedance (2 to  $8\Omega$ ) loudspeaker is used it is not necessary to use a screened cable to connect the microphone to the main unit. Ordinary bell wire will suffice.

Note that the unit may be unstable if it is switched on without a microphone connected to SK1, but the instability should cease completely when a microphone is connected to the unit.

*Note:* A crystal microphone is unsuitable for use with this device.

#### Components list for the telephone repeater

##### *Resistors* (all miniature $\frac{1}{4}W$ , 5 or 10%)

R1	1.2M $\Omega$
R2	680k $\Omega$
R3	27k $\Omega$
R4	27k $\Omega$
R5	390 $\Omega$
R6	10M $\Omega$
R7	18k $\Omega$

##### *Capacitors*

C1	100 $\mu$ F, 10V
C2	100nF type C280
C3	2.2 $\mu$ F, 10V
C4	22nF, ceramic plate
C5	47nF, type C280
C6	47nF, type C280
C7	100 $\mu$ F, 10V

##### *Semiconductors*

TR1	BC109C
TR2	BC109C
TR3	BC109C
D1	OA91
D2	OA91

##### *Switch*

S1	S.P.S.T. toggle type
----	----------------------

##### *Loudspeaker*

LS1	Miniature loudspeaker having an impedance of about 8 to 40 $\Omega$
-----	---

##### *Miscellaneous*

Case, speaker fret, etc.  
0.15in matrix stripboard panel  
3.5mm jack socket (SK1)  
PP3 battery and connector to suit  
Low impedance dynamic microphone (cassette type)  
Wire, solder, etc.