

wideband active loop antenna

for general-coverage receivers

There's nothing better than a long-wire antenna for short-wave reception, but not everyone has the necessary space. The active loop antenna described in this article can be an excellent alternative to a long-wire antenna where space is restricted. Not only is it easy to build, it also provides outstanding performance and is very inexpensive.

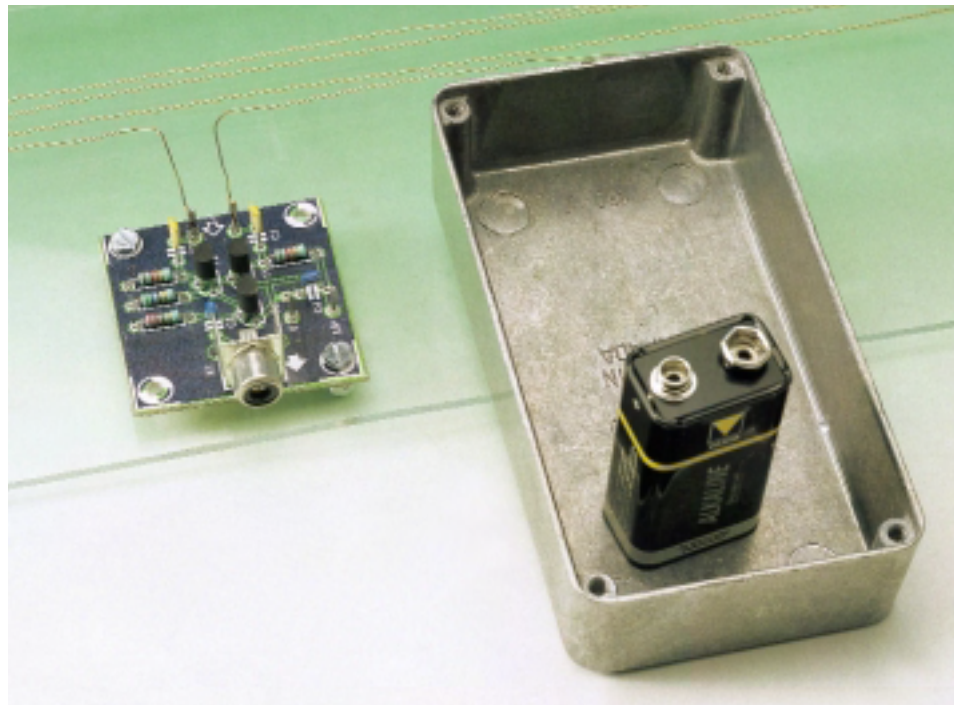

Anyone who wants to use a general coverage receiver for more than just listening to the BBC World Service or the Voice of America (VOA), soon discovers that a simple telescopic antenna has its limitations. The efficiency of such an antenna is very low, and it also picks up a lot of interference when used indoors. If you take long-distance short-wave reception a bit more seriously, you will soon find that you need something better.

What then should it be? Whole books have been written about antenna technology, and there are countless types and varieties of antennas. Before plunging into the forest of possibilities, it's a good idea to first consider what requirements the antenna in question should meet.

For a short-wave or general-coverage receiver, it is important that the bandwidth of the antenna is sufficient to cover a range of (say) 3 to 30 MHz, and that it has a reasonable efficiency within that range. If you are looking

for the simplest solution, then the 'good old' long-wire antenna is an excellent choice. Of course, there are numerous other types of antennas that are also suitable, but their construction is in most cases considerably more complicated.

The common feature of these types of antennas is that they take up a considerable amount of space, which is reason enough to regard them as typical outdoor antennas. What can you do if you have nowhere near enough space for such an antenna? Must you content yourself with the telescopic antenna, or are there other affordable possibilities?

TAKE A LOOK AT THE WINDOW

A loop antenna is a good indoor alternative for a long-wire antenna. Some people may respond to the term 'loop antenna' with aversion, since they have the idea that the only place for such antennas is a museum. This is

design by G. Baars

absolutely not true! The basic loop antenna design can still be used to construct quite useful antennas, and these antennas have the significant advantage that they are excellent for indoor use, due to their form and characteristics. For example, if such an antenna is wound around a window frame, it takes up hardly any space and is also practically invisible. In addition, a loop antenna has the desirable characteristic of reacting only to the magnetic component of the transmitted signal, which means that it rejects a large number of electrical disturbances. These features of the loop antenna — compactness and interference rejection — should not be underestimated.

LET'S GO ACTIVE!

In terms of effective surface area, the antenna described here can be roughly compared to an average long-wire antenna, since it is made from 10 to 15 metres of wire. However, since it is folded into a loop and installed indoors, the loop antenna has different characteristics and its efficiency is significantly lower.

To deal with this, there is actually no other choice than to implement an 'active' version of the loop antenna, which simply means providing it with a built-in amplifier. At the same time, the amplifier also allows the impedance of the antenna to be matched to the standard 75-ohms cable impedance.

The schematic diagram in **Figure 1** shows that such an amplifier need not be all that complicated. As can be seen, the loop antenna is connected to the inputs of a differential amplifier built using discrete components. It employs the well-known high-frequency transistor BF494 and its PNP equivalent, the BF451. The differential gain stage provides an amplification of around 10 and has a bandwidth of more than 30 MHz, which thus covers the entire short-wave band.

Transistor T3 acts as a buffer and impedance converter. The amplified signal passes to the output connector K1 via capacitor C3. A coaxial cable can be used to carry the signal from the output connector to the radio receiver.

CONSTRUCTION

Figure 2 shows the track layout and component layout of a printed circuit board design that is suitable for constructing the wideband loop antenna. This board is unfortunately not available through our Readers Services, so you will have to etch it yourself. After this is done, assembling the board should not take more than around half an hour, given the small number of components used.

Constructing the antenna itself is

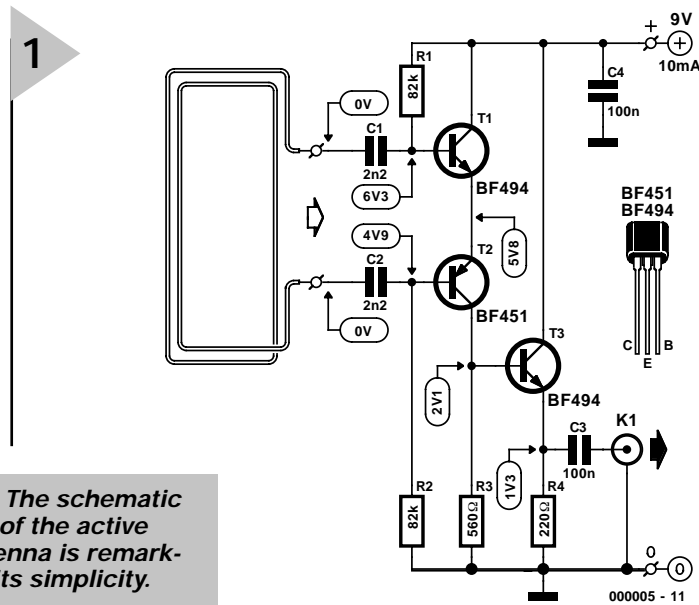

Figure 1. The schematic diagram of the active loop antenna is remarkable for its simplicity.

possibly even easier. Assuming that the dimensions of the window frame are 1 by 1.5 metres, you should wind two to four loops of insulated hook-up wire around small nails located at the corners of the frame. The core diameter of the wire is not particularly important. Be sure not to use a metallic window frame, since the antenna will not work at all with a metallic frame.

For the prototype, the window frame measured 82 cm and three turns were used. This gave outstanding results. The amplifier was fitted in a small box located at the bottom of the window frame. Since the circuit does not draw more than around 10 mA, a 9-V battery is fully adequate for the power supply. However, a stabilised (and well filtered!) mains adapter can naturally be used instead, if desired.

PERFORMANCE

With an antenna, a practical test says a lot more than a whole list of numbers. The active loop antenna was thus

extensively tested in combination with the short-wave receiver described in the January 1999 issue of *Elektor Electronics*. In a one-to-one comparison, the active loop antenna proved to perform just as well as a long-wire antenna. Both types of antenna produced essentially the same S-meter readings over the full range of the receiver. By comparison, the telescopic antenna was significantly inferior; its S-meter readings remained at around one third of the level of the other two types.

(000005-1)

Text (Dutch original): S. van Rooij
Design editing: K. Walraven

2

Figure 2. A simple design means that the printed circuit board can be delightfully compact.

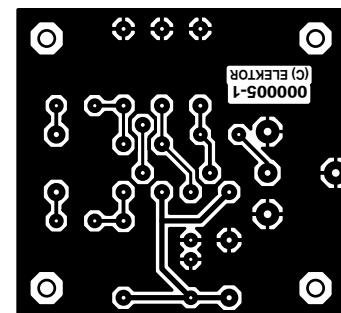
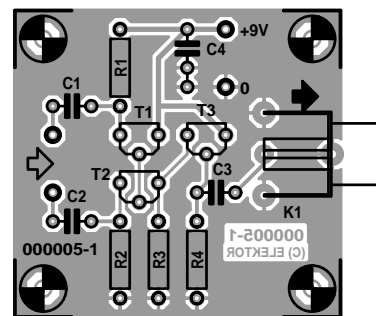

COMPONENTS LIST

Resistors:

R1, R2 = 82kΩ
R3 = 560Ω
R4 = 220Ω

Capacitors:

C1, C2 = 2nF2 ceramic, raster 5mm
C3 = 100nF ceramic, raster 5mm
C4 = 100nF, raster 5mm or 7.5mm

Semiconductors:

T1, T3 = BF494
T2 = BF451 (BF450)

Miscellaneous:

K1 = BNC or cinch socket
10 to 15 metres enamelled copper or hook-up wire