

# 80 Morse oscillator

## Introduction

This is not the simplest Morse oscillator to build, but it differs from the simple circuits in that it produces a pure note, not a coarse, rasping sound. People who have practised Morse using a non-sinusoidal oscillator sometimes find that they have trouble copying Morse code with a pure tone. As the pure tone is the correct way to receive Morse code, it is important that you should learn to listen to the code from a pure oscillator – so here’s one!

## The twin-T

There are many oscillator circuits, and there are many variations of the twin-T oscillator that we are going to use. **Figure 1** shows one version of a very useful circuit. All oscillators must have positive feedback in order to work. The feedback determines the frequency of the note produced by the oscillator.

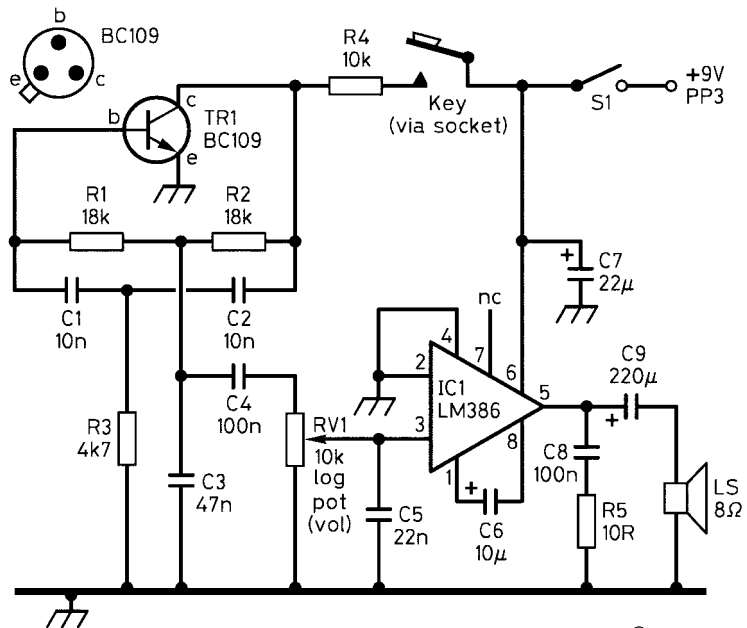

**Figure 1** Circuit diagram of the sinewave oscillator and amplifier

©RSGB DY312

Here, the feedback circuit looks like two letter Ts. If you look at Figure 1, one T is formed by R1, R2 and C3, the other by C1, C2 and R3 – hence the name ‘Twin-T’. Notice that the two Ts are connected in parallel between the collector and base of TR1, so any signal appearing at the collector is fed into both Ts. What emerges is then fed back into the base, producing in turn a signal at the collector. And so it goes on, producing a sine wave output.

The oscillator output is fed into an integrated circuit amplifier for output via a small loudspeaker.

## Putting it together

The prototype was constructed on plain matrix board (the type *without* the copper strips), as shown in Figure 2. The components have their leads pushed through the holes in the board, and connections are made underneath.

Build the amplifier circuit first, using a socket for IC1. Connect the 9V supply and touch pin 3 with an ordinary piece of wire. If a buzz is heard from the speaker, all should be well. If not, check your circuit and make changes until it does.

Build the oscillator circuit, and connect its output to the volume control VR1 via C4. Set VR1 half-way along its travel and switch on. A note should be heard from the speaker when the Morse key is depressed. The component values making up the twin-T determine the frequency of the note. Try varying them if you think your note is too high or too low. Whatever changes you make, either to the resistors or the capacitors, always ensure that  $R1 = R2$  and that  $C1 = C2$ .

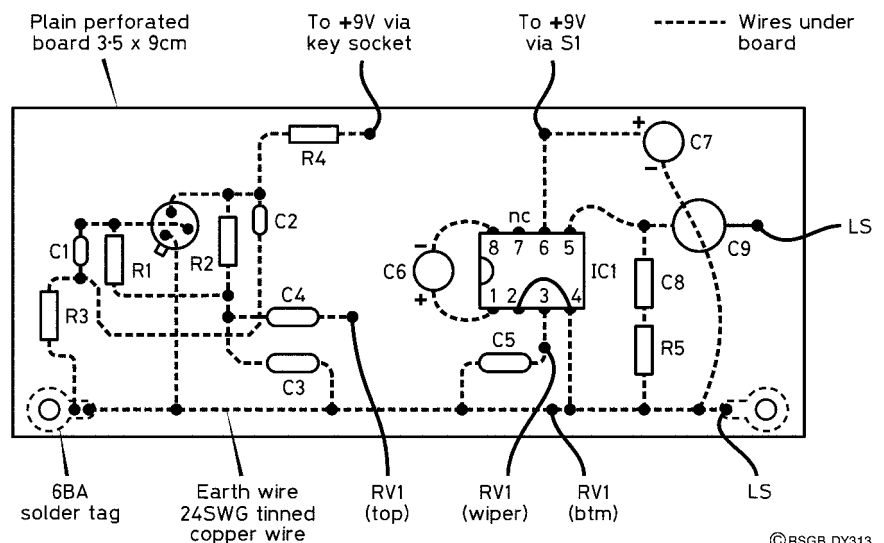

**Figure 2** Component layout and interconnection diagram

## Parts list

---

Resistors: all 0.25 W carbon film

R1, R2	18 000 ohms (18 k $\Omega$ )
R3	4700 ohms (4.7 k $\Omega$ )
R4	10 000 ohms (10 k $\Omega$ )
R5	10 ohms (10 $\Omega$ )

Capacitors

C1, C2	10 nF (0.01 $\mu$ F)
C3, C8	47 nF (0.047 $\mu$ F)
C4	100 nF (0.1 $\mu$ F)
C5	22 nF (0.022 $\mu$ F)
C6	10 $\mu$ F electrolytic, 16 V WKG
C7	22 $\mu$ F electrolytic, 16 V WKG
C9	220 $\mu$ F electrolytic, 16 V WKG

Semiconductor

TR1	BC109
-----	-------

Integrated circuit

IC1	LM386
-----	-------

Additional items

VR1	10 k $\Omega$ log potentiometer with switch
LS	8 $\Omega$ loudspeaker
Matrix board	3.5 $\times$ 9 cm
Small jack socket	for key input
Box	
PP3 battery and clip	