

# Amplifier Testbench Report

*Here's a look at broadband amps that's packed with useful insight.*

*Like many home-brewers, I've squirreled away interesting schematics for years. When I recently needed a broadband receiver amplifier covering 3–30 MHz, I found a dozen or so ideas in my files. This article presents the best nine amplifiers that I built and evaluated. While my purpose was a receiving amplifier, these designs could be used as low-level transmitter stages as well.*

Using some scrap aluminum, I made a simple test fixture to hold a 1-3/8" x 2-1/4" piece of PC board stock. I built each amplifier on a separate piece of PC stock and mounted it in the test fixture for performance measurements. I find that Manhattan-style construction is rapid and low-cost, so that's what I used for these amplifiers. Manhattan-style construction is well described at K7QO's Web site [<http://www.qsl.net/k7qo/manhat.htm>].

These are very simple projects. The

most complicated one shouldn't take more than an hour to build, and most took me less than 30 minutes.

## Performance measurements and summary

The key performance characteristics of each amplifier are presented in **Table 1**. I'll briefly describe each of the data categories that I measured. An excellent introduction to these parameters is found in Watkins Johnson Communication's Tech-note "High

Dynamic Range Receiver Parameters." It's available on WJ's Web site at [<http://www.wj.com/pdf/technotes/HighDynRangeRec.pdf>].

- Midband gain — the power gain of the amplifier, measured at 5.0 MHz
- -3 dB Frequency — the high frequency at which the gain of the amplifier drops 3 dB below the midband gain. Since I was not interested in low frequency performance, I didn't measure the low-frequency 3 dB point; all were flat down to 3 MHz, the lowest frequency I was interested in. However,

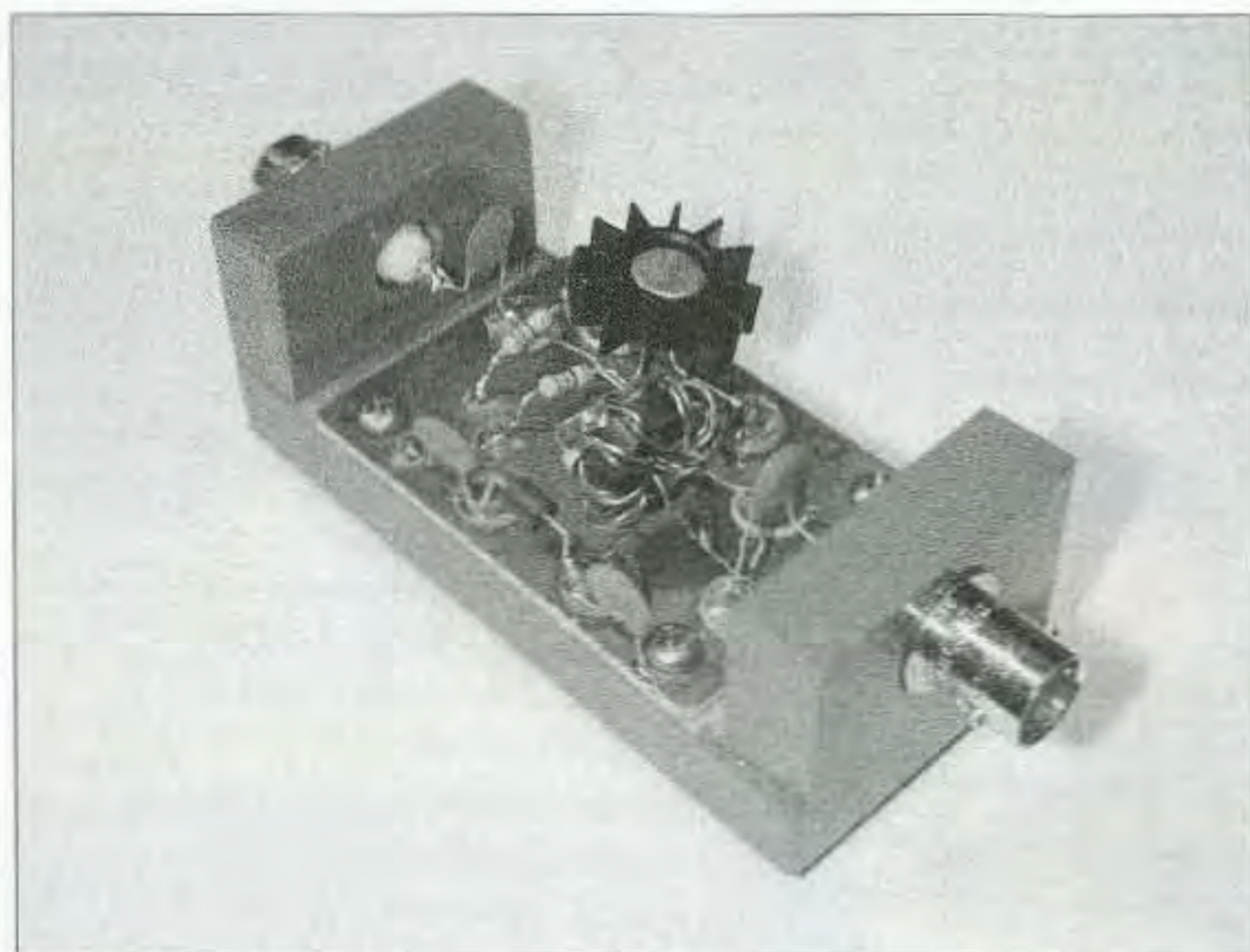

**Photo A.** Test fixture and sample Manhattan-style amplifier.

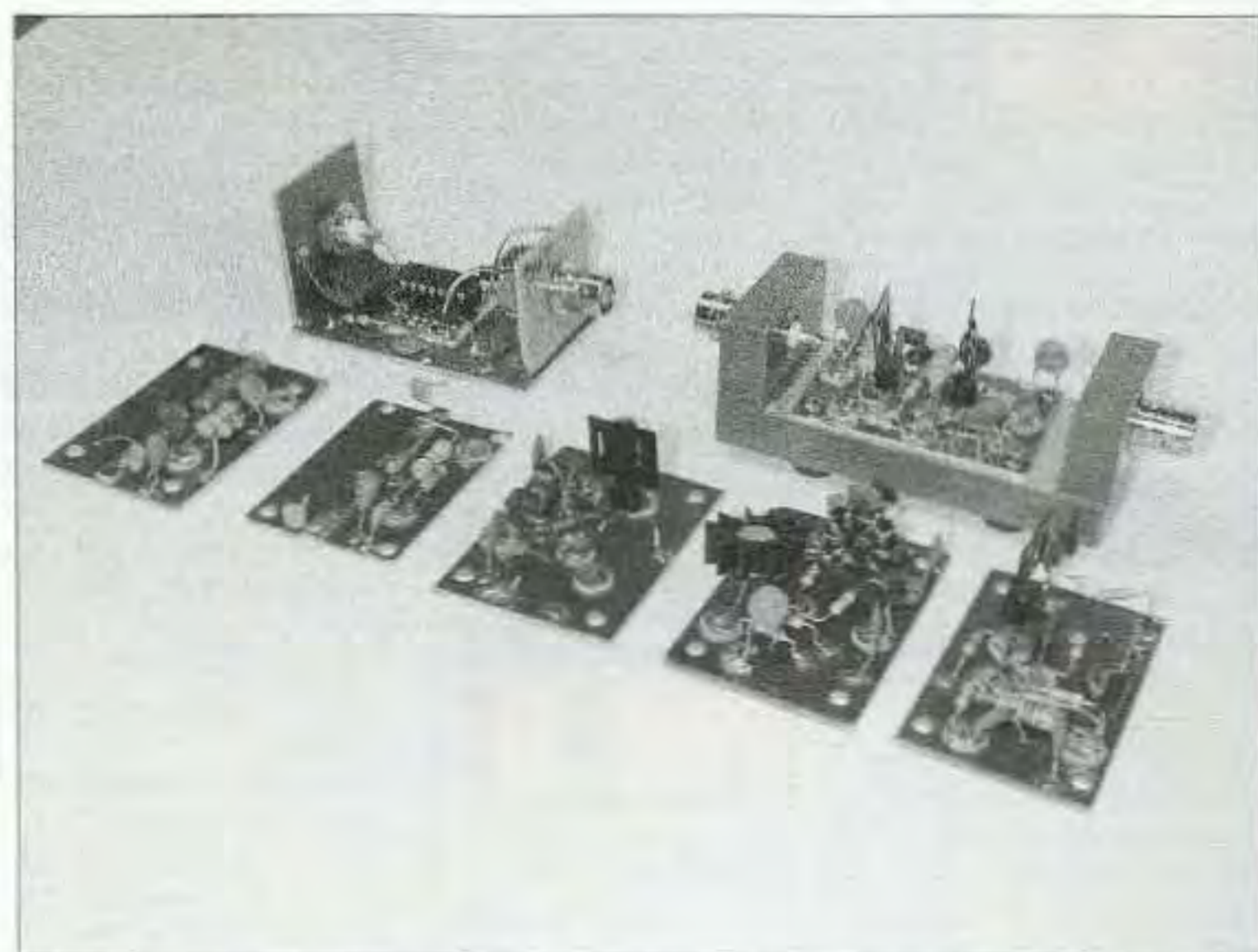

**Photo B.** Some of the evaluation amplifiers built by the author.

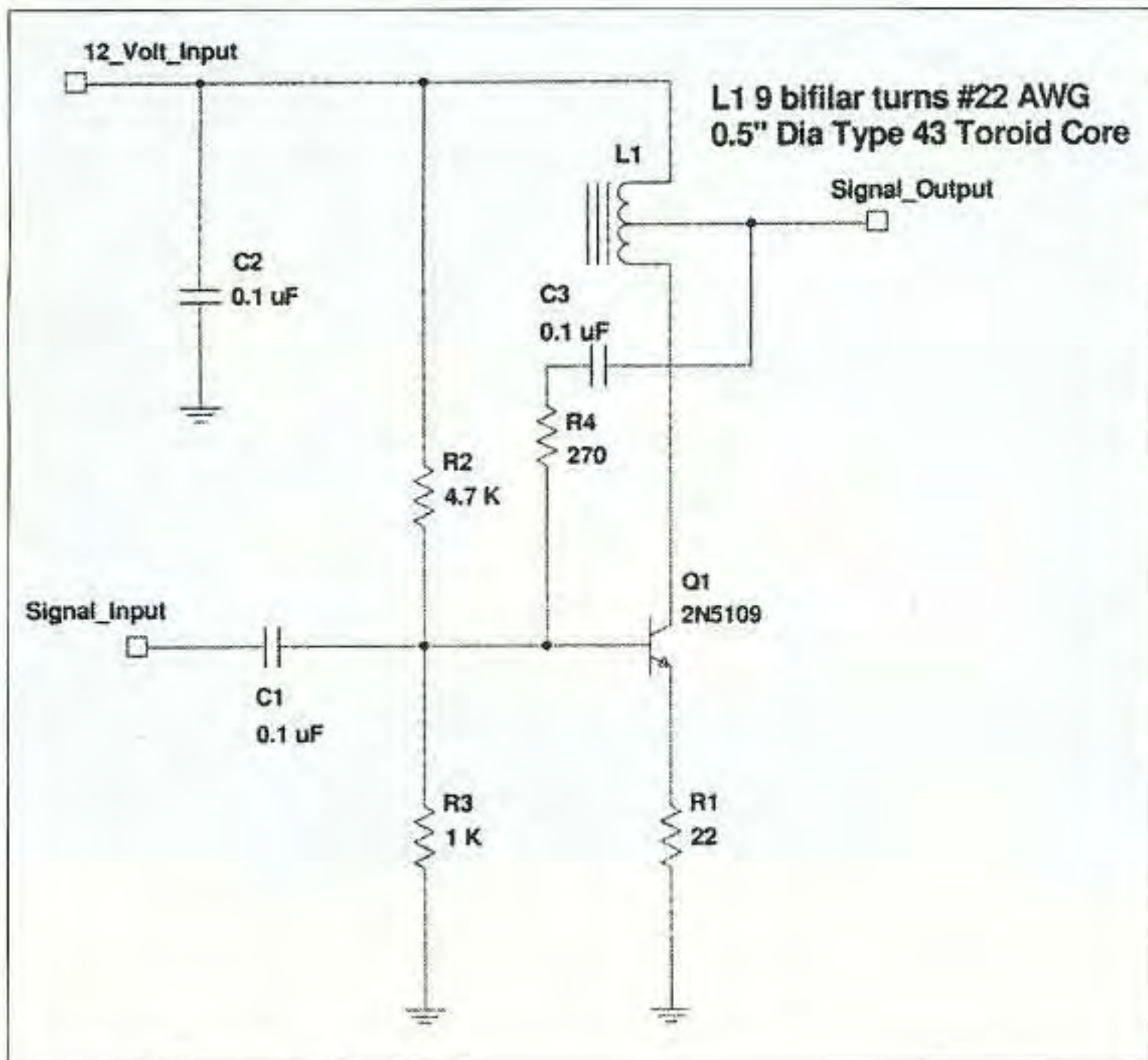

Fig. 1. Classic 2N5109.

casual checks show that most of these designs perform well down to 100 kHz or lower.

- Input IP2 and Output IP2 — second-order intermodulation intercept point, measured with respect to the second harmonic of a 5 MHz signal. Input IP2 is referenced to the input signal, while Output IP2 is referenced to the output signal level. Output IP2 = Input IP2 + midband gain.

- Input IP3 and Output IP3 — third-order intermodulation intercept point, measured with two equal-level input signals of 5.0 and 6.0 MHz. Input IP3 is referenced to the input signal, while Output IP3 is referenced to the output signal level. Output IP3 = Input IP3 + midband gain.

range, and normal antennas, atmospheric noise is the dominant factor, and achieving a low noise figure is often not critical.

- Input VSWR — the worst-case VSWR of the amplifier input over the 3–30 MHz range.

- Spurious-Free Dynamic Range — this is a single measure attempting to capture the total amplifier performance. Watkins Johnson describes it as “that portion of the total dynamic range where there are no 3rd order spurious responses exceeding the noise floor by 3 dB when two equal-power input signals are applied.” I’ve calculated the SFDR based on a typical voice SSB bandwidth, using

Continued on page 12

- Output power (1 dB compression) — a perfect amplifier shows the same gain, regardless of input signal level; real amplifiers can’t increase power past some certain level. The 1 dB compression point is the amplifier output power at which the gain drops 1 dB from the low-level gain.

- Noise figure — the noise figure represents the excess noise added by the amplifier. For the 3–30 MHz

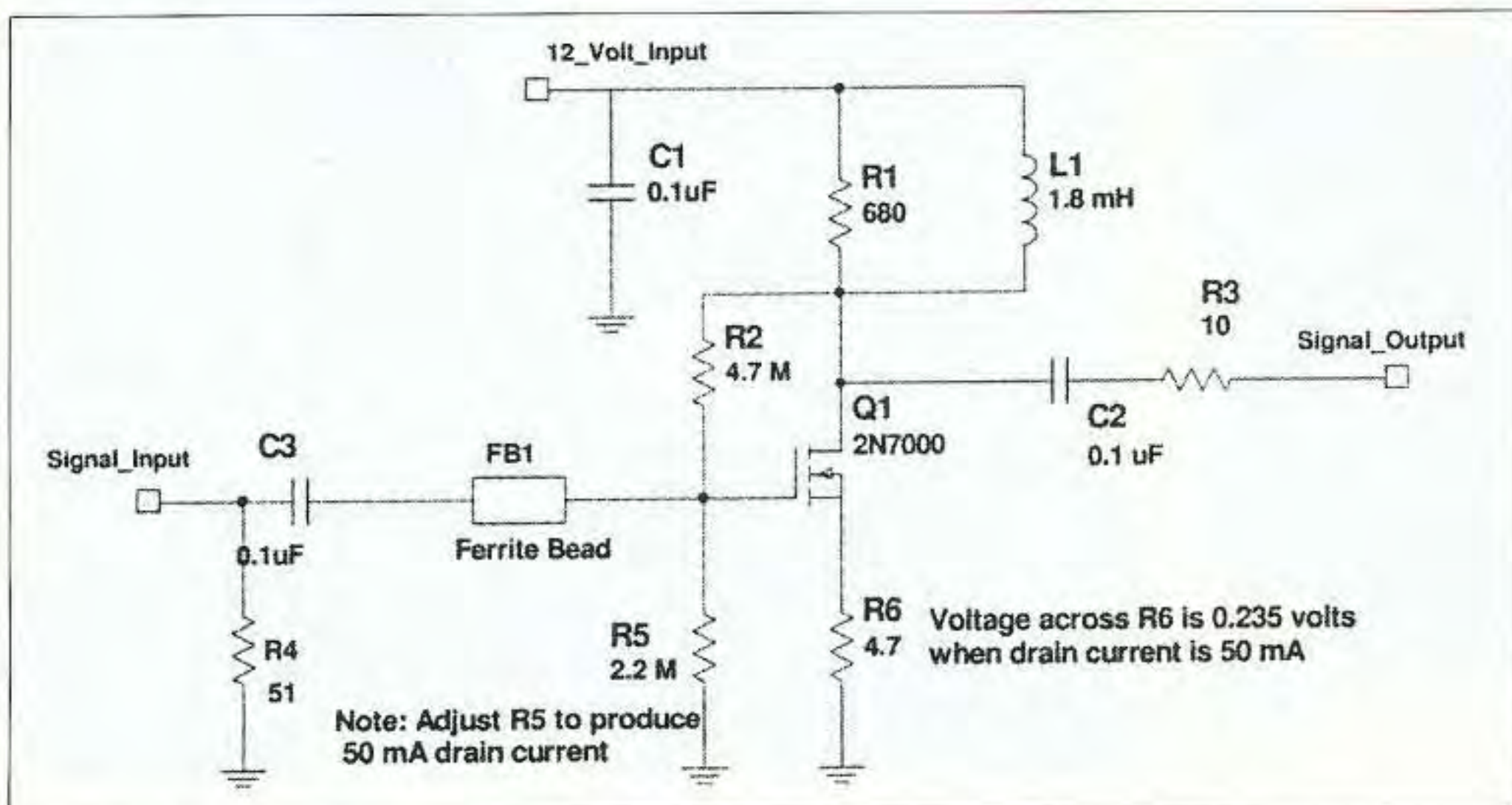

Fig. 2. 2N7000.

# ALL ELECTRONICS CORPORATION

SHOP OUR ONLINE STORE  
[www.allelectronics.com](http://www.allelectronics.com)

## 5MM BLUE LED SPECIAL

High-brightness blue LED. 1000 MCD. Water-clear in off state. Special price.

CAT# LED-86

\$1.75 each

10 for \$1.50 each  
 100 for \$1.15 each  
 1000 for 95¢ each

## 25 WATT POWER SUPPLY

Autec # UPS25-1002T

Input: 115v/1.5A or 230V/0.75A

Output:

5V @ 1.9A,

12V @ 1.6A.

25 Watt switching

supply mounted on an L-bracket,

9" x 2.27" x 2.25" overall. Standard three

prong IEC socket power input. On-Off rocker

switch. Molex-type connector output.

UL, CSA recognized.

CAT# PS-251

\$4.25 each

10 for \$3.50 each

## 1 Farad 2.5 Volt Supercapacitor

PowerStor (tm) # B0810-2R5105

In addition to battery back-up

applications, these capacitors

can be used to provide short,

high-current pulses for

electronic and electro-

mechanical applications.

Features include: Extremely low ESR.

Ultra low leakage current - can hold a

charge for several weeks. Very high

charge-discharge cycle life. High usable

capacity - high energy that can be dis-

charge quickly.

0.33" diameter x 0.47" high.

0.16" (4mm) cut & bent pc leads.

CAT # CBC-125

10 for 85¢ each  
 100 for 70¢ each

\$1.00 each

ORDER TOLL FREE  
 1-800-826-5432

CHARGE ORDERS to Visa, Mastercard,  
 American Express or Discover

TERMS: NO MINIMUM ORDER. Shipping and handling for the 48 continental U.S.A. \$6.00 per order. All orders including AK, HI, PR or Canada must pay full shipping. All orders delivered in CALIFORNIA must include local state sales tax. Quantities Limited. NO COD. Prices subject to change without notice.

CALL, WRITE  
 FAX or E-MAIL  
 for our FREE

96 Page  
 CATALOG

Outside the U.S.A.  
 send \$3.00 postage.

MAIL ORDERS TO:  
 ALL ELECTRONICS  
 CORPORATION  
 P.O. Box 567  
 Van Nuys, CA 91408  
 FAX (818)781-2653

e-mail [allcorp@allcorp.com](mailto:allcorp@allcorp.com)

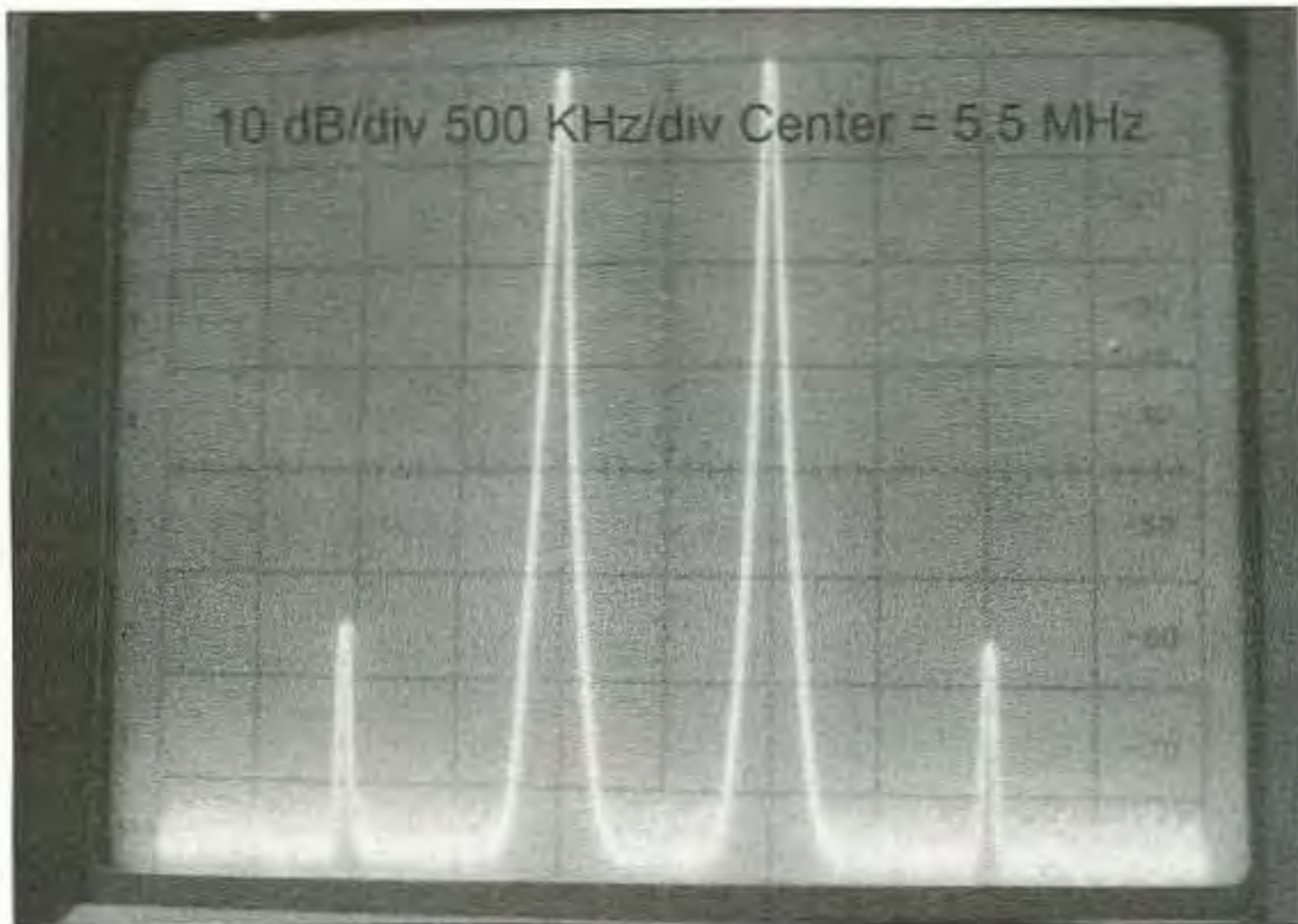

**Photo C.** Intermodulation test of 2N5109 amplifier showing intermodulation products down 56 dB from -4 dBm input.

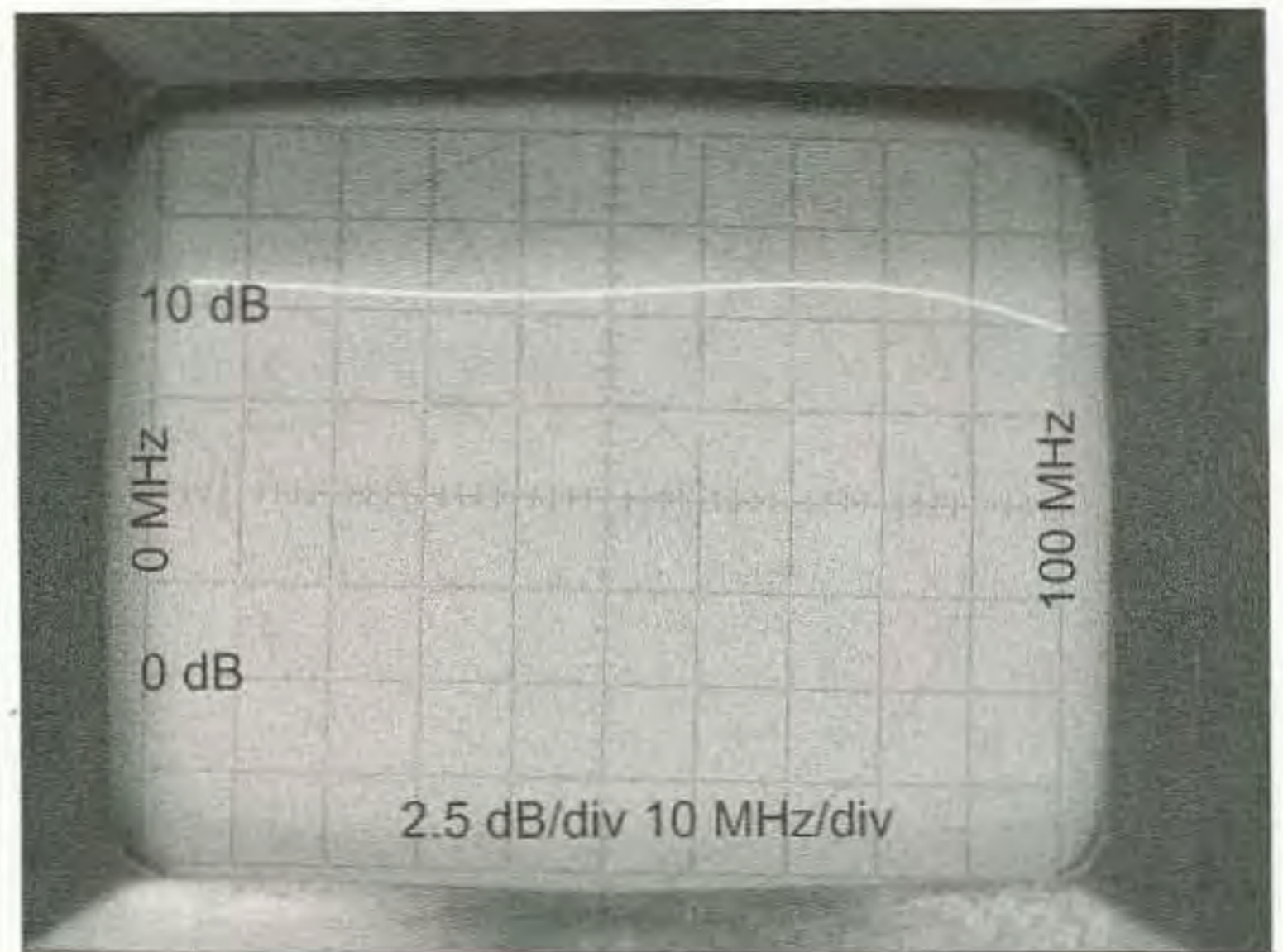

**Photo D.** Typical gain versus frequency sweep (2N5109 amplifier).

## Amplifier Testbench Report

*continued from page 11*

the measured performance data for each amplifier.

I've shown signal levels in dBm, or decibels below one milliwatt power, referenced to 50 ohms. I've taken reasonable care in making these measurements, and used professional quality test equipment. Still, many of these parameters are level-sensitive, so use the data with some degree of caution when comparing with other sources of information.

### Which one to use?

Each of these amplifiers has a purpose. For a receiver preamplifier, my favorites are the classic 2N5109 or the newer NE461M02 amplifiers. If you are looking for pure simplicity, the

MAR MMIC amplifiers are hard to beat, particularly if you have a controlled signal environment, such a low-level stage in a transmitter. For minimum noise figure, a J310 in grounded gate is the clear choice, and it's an excellent performer by all other standards as well.

I've not been concerned with performance beyond 30 MHz in these amplifiers. Some of these designs will work into the GHz range, if you use proper construction practices and appropriate components. Even with normal leaded components and sloppy breadboarding practices, performance well beyond 500 MHz is possible with some of these amplifiers.

### Classic 2N5109

Drake used this design as the RF

preamplifier stage in its late-1970s R7 receiver. Slight variants of it appear in several books by Doug DeMaw, including his 1990 *WIFB's Design Notebook*. Regardless of the originator, it's still an impressive performer, clocking in the best spurious free dynamic range, IP3, and IP2 values of the amplifiers I built, and offering a decent noise figure as well.

The design is a simple common emitter amplifier, with an unbypassed emitter resistor to add degeneration. Transistor selection is important, and the 2N5109 was developed for CATV applications where gain linearity and intermodulation control are critical.

R4 provides significant negative feedback, which both reduces the input impedance to 50 ohms and flattens the gain versus frequency response. Indeed,

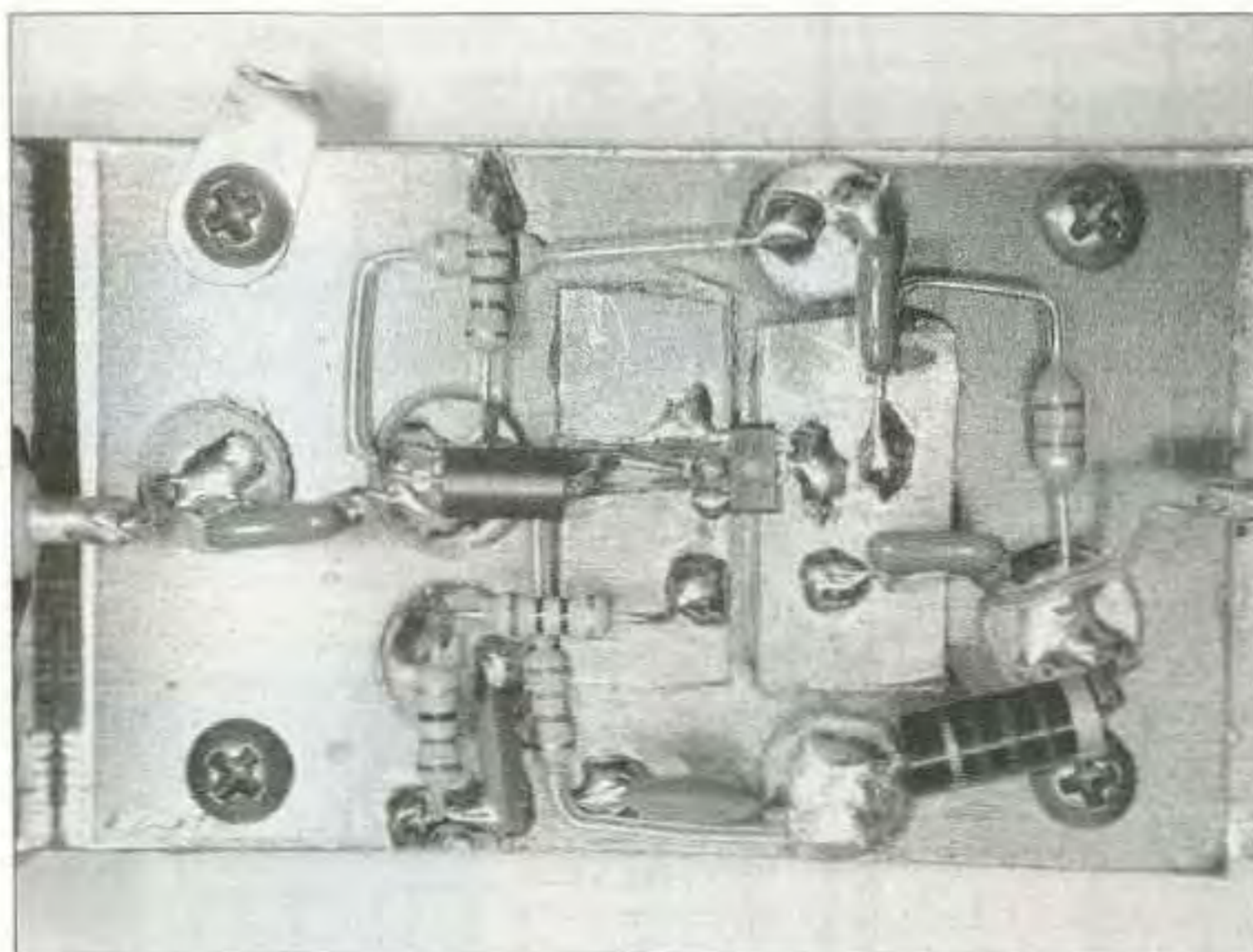

**Photo E.** Mounting the SMD transistor in a Manhattan breadboard.

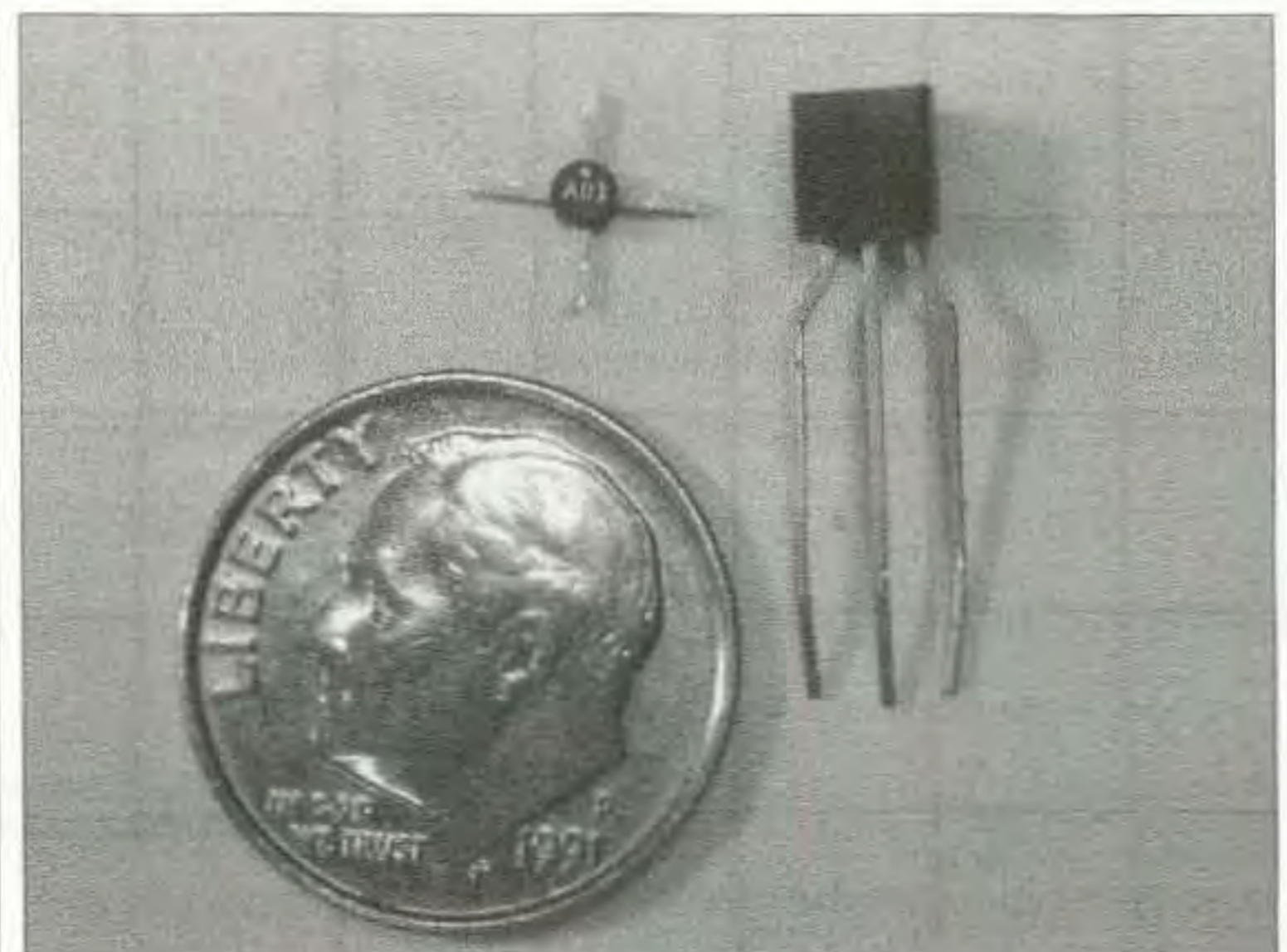

**Photo F.** MMICs are tiny. The MMIC is the tiny round device with four leads.

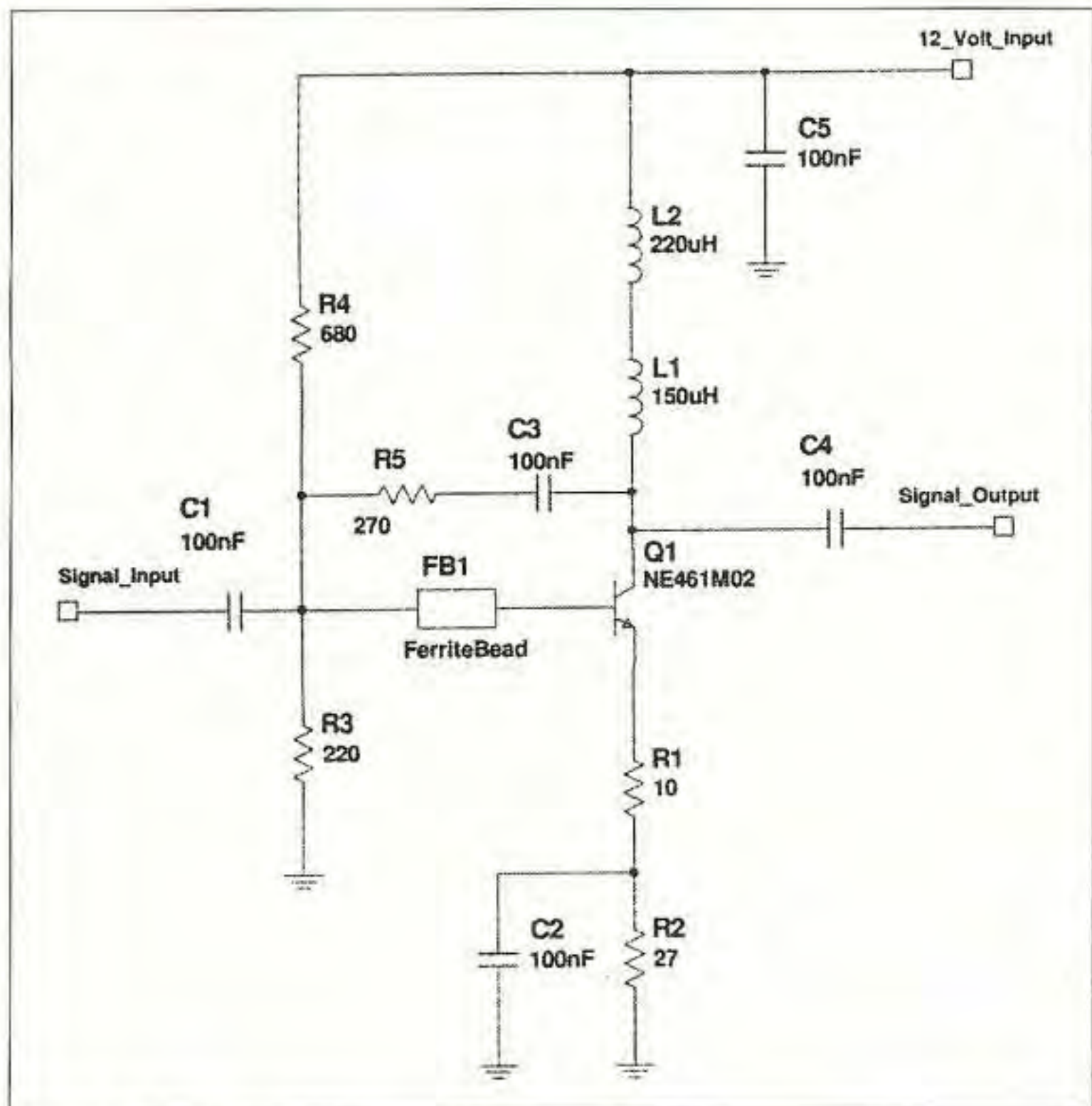

Fig. 3. HF1000 preamp.

the input VSWR is remarkably good throughout the 3–30 MHz range. I used a 0.1  $\mu$ F input coupling capacitor to extend the low frequency response below 100 kHz. Drake used a 0.005  $\mu$ F coupling capacitor to roll off strong broadcast signals. If you are not interested in gain below 3 MHz, use 0.005  $\mu$ F.

The output is connected to the collector through an autotransformer, shown as L1 in the schematic. Drake doesn't specify L1 other than by a part number, but it appears to be around 9 bifilar turns wound on a 0.5-inch-diameter toroid using a high  $\mu_r$  material. I used 9 bifilar turns of #22 AWG wire

an interesting low-frequency MOSFET preamp using a VN10KM device [http://www.qsl.net/wa1ion/bbva/bbva\_af1.gif]. I've modified WA1ION's design to use the common 2N7000 enhancement MOSFET.

R4 provides a 50-ohm termination to the signal source. Ferrite bead FB1 is a "stopper" to prevent self-oscillation. R2 and R3 provide bias to the 2N7000. Note that R2 is connected to the drain, not the 12-volt supply, thus providing some negative feedback. The output is connected directly to the drain, with

Continued on page 14

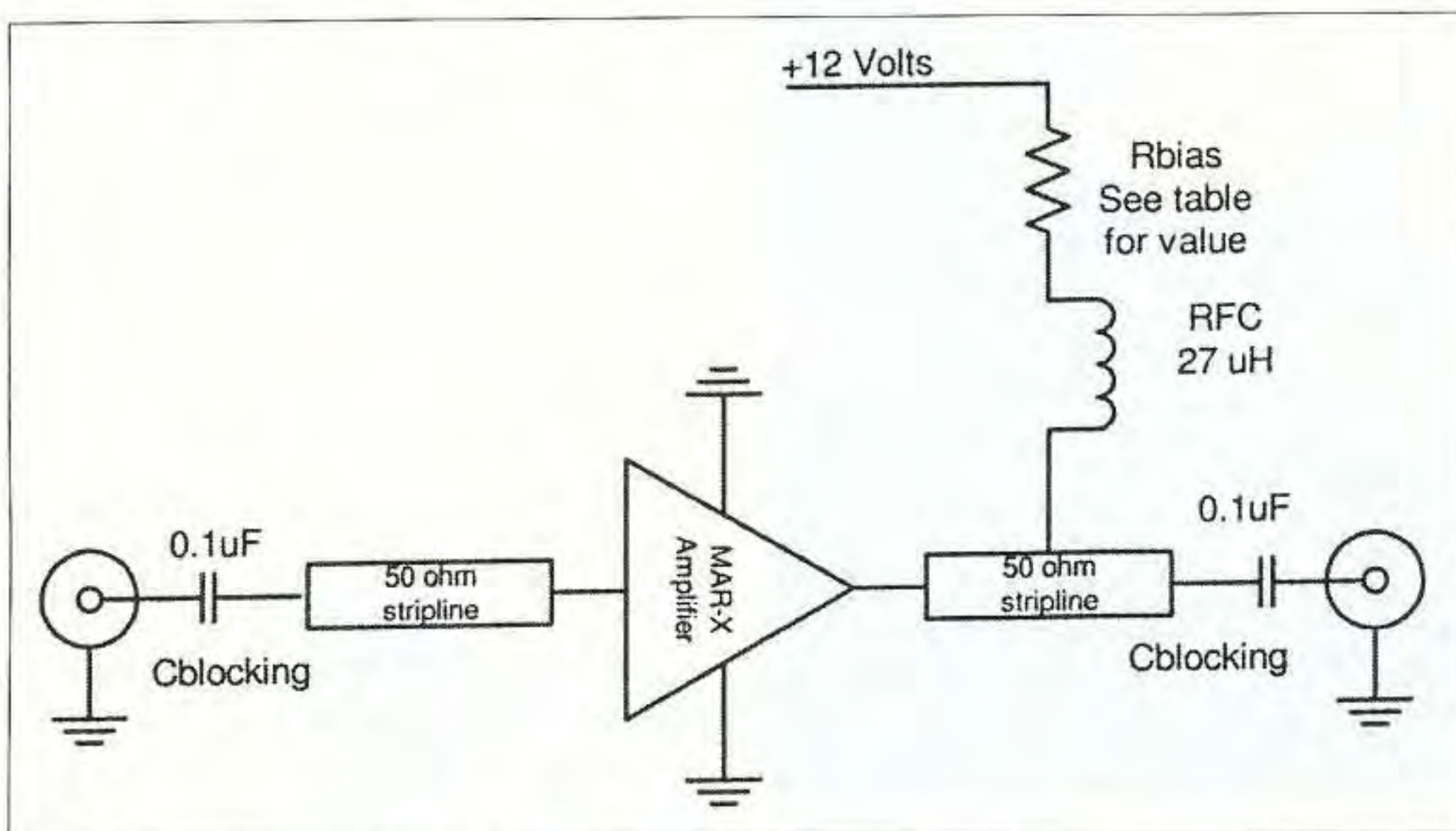

Fig. 4. Generic MMIC amplifier.

wound over a Fair-Rite 5943000301 (FT50-43) core.

The 2N5109 draws around 50 to 60 mA current, and should be equipped with a clip-on heat sink. Slightly better intermodulation performance will be seen with a 13.8 volt supply instead of 12 volts.

### 2N7000

MOSFETs are also candidates for linear amplification of strong signals. WA1ION's Internet site describes

### HamCall™ CD-ROM

U.S. & International - Over 1.63 million listings



We make a new HamCall every month! Clearly, the most current and complete CD-ROM available.

#### Latest Features

- Choose font and color of data display.
- Displays flag and map for each country.
- Shows CQ, ITU zone, and continent.
- History list shows each callsign entered.
- Print labels in a variety of formats.
- View & search interests of 39,000 hams.
- Search for club, military, vanity, silent keys, name, address, and more.

Over 1,631,000 U.S. and International listings, 128,000 e-mail addresses, 4,000 photos and QSL cards, 37,000 vanity calls, and 20,000 references to QSL managers.

Shows path distance & bearing.  
Precise latitude/longitude for over 90% of addresses.  
HamCall is \$50.00, included is 6 months free access to our HamCall Internet Service - request when ordering.

HamCall Mousepad, with morse code reference, 7.5" x 8", blue with yellow letters. \$5.00 + \$3 shipping.

\$5.00 shipping (\$8 Intl) per order. Your satisfaction guaranteed!

**BUCKMASTER**  
6196 Jefferson Highway • Mineral, VA 23117 USA  
e-mail: info@buck.com  
540-894-5777 • 800-282-5628 • 540-894-9141 (fax)

**Over 12,000 HAM Items in Stock!** **208-852-0830**  
<http://rossdist.com>

**cushcraft**  
**ASL-2010**  
Under \$620.00

**RDC** Check Out Our Specials! We're On The Web.  
**ROSS DISTRIBUTING COMPANY** All Prices Cash  
78 S. State Street, Preston, ID 83263 FOB Preston  
Hours Tue-Fri 9-6 • 9-2 • Closed Saturday & Sunday

### Your FT-817 needs a Miracle!



The **Miracle Whip** lets you operate your new QRP rig with real freedom! It is a completely self-contained, all-band 50-inch telescoping whip antenna with integrated tuner for receiving and transmitting that mounts right on your radio. The Miracle Whip liberates your rig from coax, cables, mounts, tripods and trees, and gives

you remarkable DX performance from desktop to picnic table, with no ground required. Take your portable transceiver anywhere and operate from 3.5 to 450 MHz with up to 20 W SSB. Only 13 inches collapsed. This quality product features gold plated rotor contacts and hand-formed solid brass contractors. Manufactured by Miracle Antenna of Montreal with three year limited warranty.

Order #3256 \$148.95 (+\$9.95 UPS)

**universal radio inc.**  
6830 Americana Pkwy.  
Reynoldsburg, OH 43068  
♦ Orders: 800 431-3939  
♦ Info: 614 866-4267  
[www.universal-radio.com](http://www.universal-radio.com)

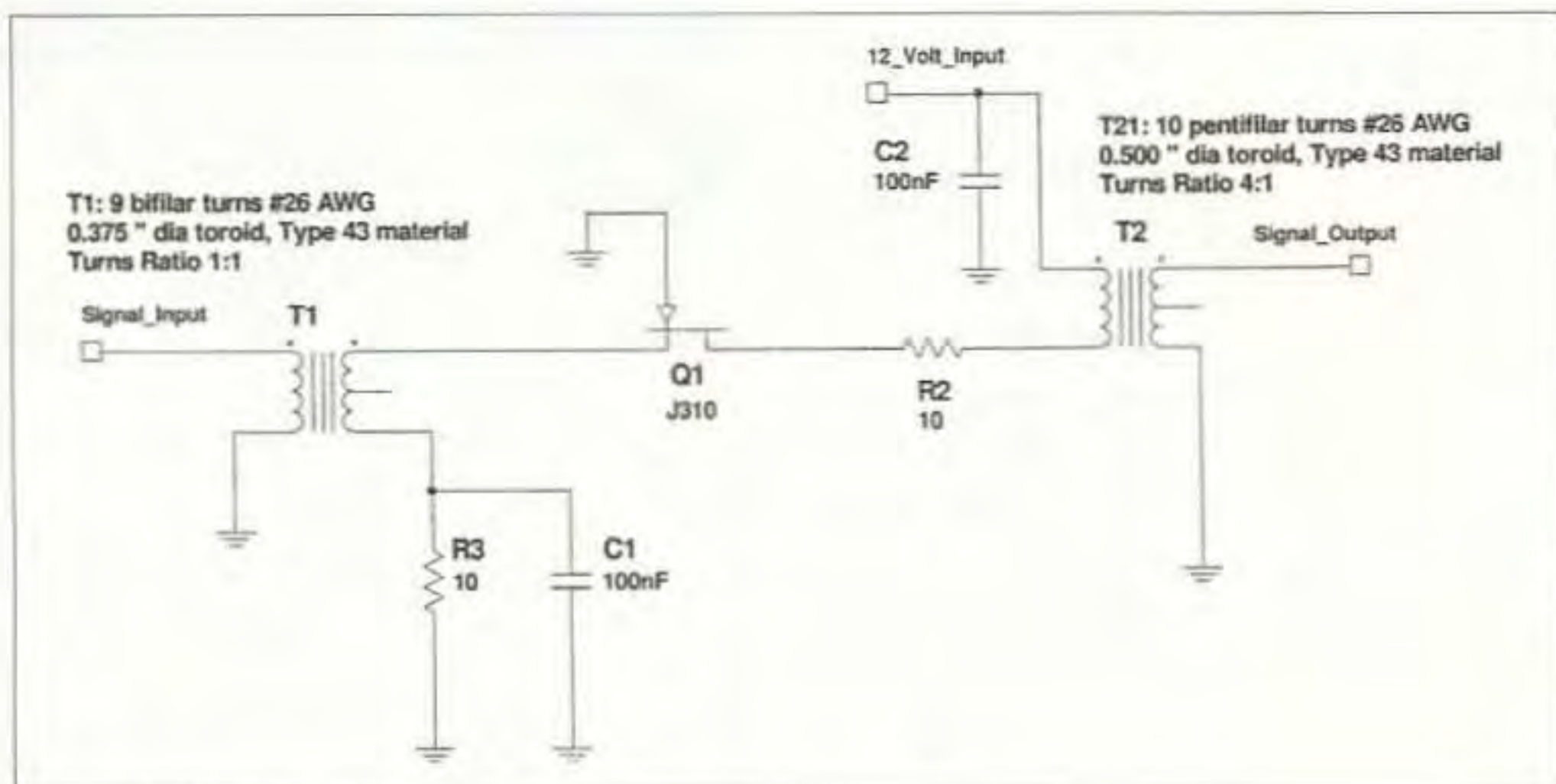

Fig. 5. J310 grounded gate.

## Amplifier Testbench Report

continued from page 13

R3 protecting Q1 should the output be short-circuited.

MOSFET devices are not well controlled for gate threshold voltage, so it will likely be necessary for you to select R5 to obtain the target 50 mA drain current. Start with 2.2 megs and measure the current draw. If it is below 50 mA, increase R5; if it exceeds 50 mA, decrease R5. Once established, the drain current will be stable, so this is a set-once-and-forget task, assuming Q1 isn't replaced.

At the recommended 50 mA drain current, Q1 will dissipate around 600 milliwatts, which exceeds the device rating. I use a slip-on heat sink and have not had a problem with 2N7000

failures. If you wish to run Q1 within its ratings, adjust R5 to 20 mA. A heat sink is still a good idea, however. Operating Q1 at 20 mA will slightly reduce the intermodulation performance of the amplifier.

### Watkins-Johnson HF1000 preamp

The preamplifier stage in Watkins-Johnson's HF1000 receiver has a familial resemblance to Drake's R7 design. However, WJ opted for direct coupling from the transistor collector and used a more modern transistor. WJ used a hard-to-find Philips BFQ19 surface-mount microwave NPN transistor, with an  $f_t$  of 5 GHz. I substituted a similar device from NEC, a surface-mount NE461M02/2SC5337, available from Mouser Electronics for

\$1.71. I also made a few other changes in WJ's design to reflect its use as a stand-alone amplifier.

Using a GHz-range microwave transistor for a 3–30 MHz preamplifier is certainly overkill, but it turns out that the 2-watt NE461M02 is about half the price of the lower-frequency 2N5109.

Instead of transformer coupling, this design directly feeds the 50-ohm output. Otherwise, it's quite similar to Drake's R7 design.

Breadboarding the NE461 is possible with a bit of care. The collector tab is designed to be directly soldered to a pad. Since the transistor dissipates nearly 1 watt, it's important to have a large copper area for the collector to act as a heatsink. Staying with the Manhattan-style construction technique, I cut a rectangular piece of PC stock about 1/2" x 3/4", and then super-glued it to the base PC board, and soldered the transistor's collector tab to it. I used a similar-size piece of PC stock for the emitter tab. This technique introduces several picofarads of stray capacitance from the collector and emitter to ground. Computer simulation of the design showed that the stray capacitance in my breadboard technique reduces the 3 dB bandwidth from over 500 MHz to about 100 MHz. So, if you are interested in a very broadband amplifier using this circuit, you should use a construction technique that minimizes stray capacitance, such as mounting the collector PC board vertically, or removing the ground plane underneath the collector pad.

This was the only circuit that was unstable when first built, with a strong parasitic oscillation around 1.3 GHz. A ferrite bead in series with the base lead stopped the parasitic but further decreases the 3 dB bandwidth.

### Three MMIC amplifiers

MMICs (monolithic microwave integrated circuits) are deceptively simple. A MMIC is a tiny integrated circuit that offers a 50-ohm input and output impedance. With fewer than 10 parts, you can build an MMIC amplifier that offers flat gain from DC through the GHz range. No wideband transformers



Photo G. MAR-3 amplifier in the test fixture, showing Manhattan construction, including strip lines.

to wind; no complicated impedance matching.

A wide variety of MMICs is available from many manufacturers, and I tested three from among the nearly three dozen offered by Mini-Circuits Laboratories [http://www.minicircuits.com]. The MAR-1 through MAR-8 series is the original MMIC offering by Mini-Circuits; these are widely available at prices in the \$1 to \$2 range. Hence, I built test amplifiers with MAR-3, MAR-6, and MAR-8 MMICs, representing low, medium, and high gain chips. The MAR-series chips don't represent state-of-the-art in MMIC performance, but remain quite useful for HF through low UHF experimentation. (The leaded MAR-X series has recently been replaced by surface mount MAR-XSM packages. The device specifications important for HF use, however, have not materially changed, and the older leaded packages continue to be available on the surplus market.)

If you are to achieve decent performance in the GHz-plus range, you will need to pay careful attention to layout, component choice, and printed circuit board material. I was interested only in amplifiers up to 30 MHz or so, and I was able to get away with less-than-optimum construction techniques and components. Even so, the Manhattan-style construction I used worked reasonably well beyond 500 MHz. (The MAR-6 amplifier, I built from a kit.)

The MAR chips contain built-in bias elements, and both the input and output are at a positive DC voltage with respect to ground. Hence, both input and output require a blocking capacitor,  $C_{\text{blocking}}$ . I used 0.1  $\mu\text{F}$  disc ceramics. (Good low-inductance surface-mount chip capacitors should be used if UHF performance is desired.) I used an 8.2  $\mu\text{H}$  RF choke in addition to the bias resistor. The MAR chips require, depending on the particular model, between 3.5 and 7.8 volts, and must be run from a higher supply voltage through a series bias resistor,  $R_{\text{bias}}$ . If you don't use an RFC,  $R_{\text{bias}}$  shunts the output, so you will lose some gain — typically 1 to 2 dB. If you use a common leaded RFC, expect to see a dB or so of gain ripple

over the 3–100 MHz range caused by choke resonances. Omitting the RFC will give almost ruler-straight (but lower) gain versus frequency over this range. If you use a choke, it should provide at least 500 ohms reactance at the lowest frequency of interest. For the 3–30 MHz range, the RFC should be at least 27  $\mu\text{H}$ . (Special, resonance-free chokes are available where both

maximum gain and maximum flatness are important.)

It's important to have a good ground plane for MMICs, and the Manhattan-style construction helps in this regard. I made the input and output connections with 50-ohm strip line. For standard 0.062-inch glass epoxy PC board material, the trace width for 50-ohm strip line is 0.158 inches. I just milled

# RIGrunner

## Intelligent DC power panel

- Conveniently power your station with Anderson PowerPole® connectors.
- 40 Amps total, outlets to run all of your transceivers and accessories.
- Each and every outlet individually ATC fused with LED open fuse indicators.
- Precision LED and audio alert of safe, over or undervoltage, 4012 & 4008.
- No messy binding posts, frayed wires, black tape or short circuits.
- Safe, secure, hot connect, polarized, color keyed, unisex, connector system.
- Conforms to the ARES, RACES, RSGB recommended standard.
- Perfect for home, mobile, rover, portable, emergency and contest stations.

**3 Models from \$49.95!**



# RIGblaster

## Have more fun with your radio

The only no compromise sound card interfaces.

The easiest to set up, high quality, complete solution.

The best support too!  
Read our user comments!

Get on WSJT JT44, the extreme weak signal mode!

**RIGblasters: M8, M4, RJ, Plus or Nomic**

<http://www.westmountainradio.com>

**West Mountain Radio** de N1ZZ and K1UHF

18 Sheehan Avenue, Norwalk, CT 06854 (203) 853 8080



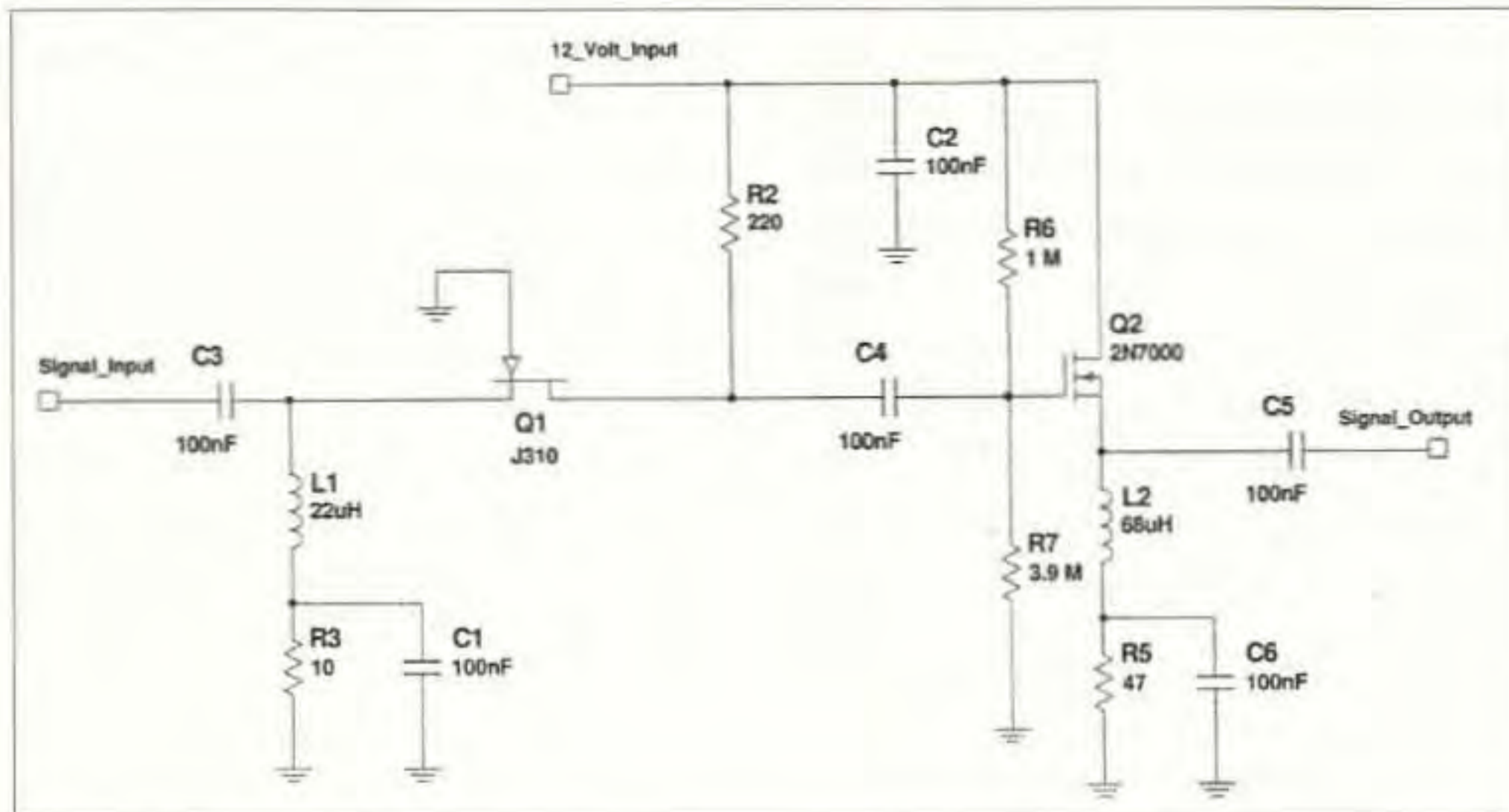

Fig. 6. J310 grounded gate and 2N7000 source follower.

a sliver of scrap PC stock to 0.158-inch width and Super-glued it just as if it were a Manhattan-style pad. This approach makes the MMIC stick up above the board surface, so the two ground leads are longer than desired. For HF use, strip line construction is not necessary. Remember, however, that MMICs have gain well into the GHz range, and sloppy layout could yield an oscillator, not an amplifier. Use a good ground plane and layout to keep the output clean. I did not see any indication of oscillation up through 1.5 GHz in my test circuits.

It's good practice to connect an amplifier in the following sequence: first, connect the output; second, connect the power ground; third, connect the power positive; and last, connect the

amplifier input. I didn't follow this sequence as carefully as I should, and consequently destroyed two MMICs while running tests.

### J310 grounded gate

Grounded-gate FET amplifiers have a good reputation for low noise performance, and the J310 circuit doesn't disappoint in this regard, turning in the best noise figure of the amplifiers I built.

The input impedance of a J310 in grounded-gate configuration is close to 50 ohms, so the input transformer should have a 1:1 turns ratio. Since the output transformer primary carries the same signal current as the secondary of the input transformer and we have designed for 50-ohm impedance at

both the input and output, the voltage gain of this amplifier is simply the ratio of the transformer turns. In this case, T2's primary has a turns ratio of 4:1; hence the theoretical voltage gain is 4, or 12 dB. (The impedance of the output 50-ohm load seen by Q1's drain transformed by T2 is 800 ohms. This gives a voltage gain of 16:1. However, T2 has a 4:1 voltage step-down ratio. Hence the net voltage gain into the 50-ohm output is 4:1.) T1 and T2 carry the DC drain current as well; thus some care should be taken to avoid core saturation, particularly with T2. The size cores suggested on the schematic are satisfactory. (A no-transformer version of the grounded-gate J310 is shown later.)

This is a good-performing amplifier with a very good noise figure, but a disappointing high frequency response. Computer simulation suggests that the upper 3 dB frequency corner should be nearly 100 MHz. I was unable to coax the high frequency response past 21 MHz, despite extensive experiments with different output transformer designs.

### J310 grounded gate and 2N7000 follower

With a little extra work, we can eliminate the transformers from the J310 grounded gate amplifier.

The input transformer can easily be replaced with an appropriate RFC and blocking capacitor. The RFC carries the DC current, but looks like high impedance to the RF input. C3 blocks the DC from the signal input.

We can replace the output transformer with a load resistance, R2. Since the same signal current flows through R2 and the input source, the voltage gain is the ratio of R2 to the 50-ohm input source, or, for the 220-ohm resistor in my design, 4.4:1, or 12.8 dB.

To connect the amplified signal to the 50-ohm output, we can use a source follower. A source follower has high input impedance and low output impedance and thus efficiently couples the signal amplified by Q1 to a 50-ohm output port. Our test circuit uses a 2N7000 MOSFET follower. A source follower has a voltage gain slightly

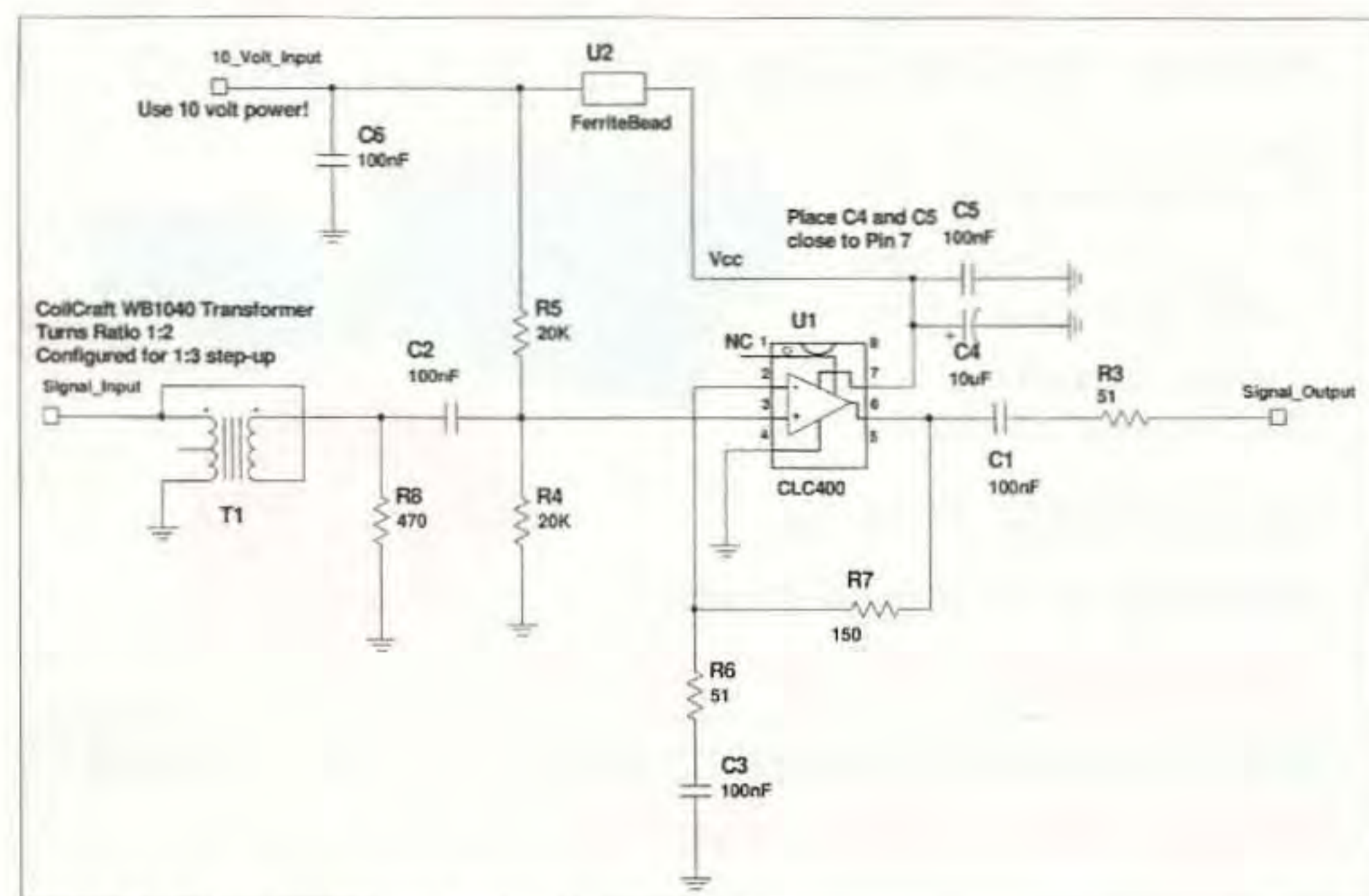

Fig. 7. CLC400 high-speed op amp.

Amplifier Configuration	5 MHz Gain (dB)	-3 dB Frequency (MHz)	Input IP2 (dBm)	Input IP3 (dBm)	Output Power dBm (1 dB Comp)	Noise Figure (dB)	3-30 MHz Input VSWR (max.)	Output IP2 (dBm)	Output IP3 (dBm)	Spurious Free Dynamic Range (dB)
2N5109	11	125	56	33	24	5.8	1.22:1	67	44	109
2N7000	13	34	36	23	26	8.4	1.50:1	49	36	101
J310 & 2N7000	11	62	44	23	24	7.1	1.29:1	55	34	101
J310 GG High Gain	10	21	55	28	20	4.2	1.29:1	65	38	107
MAR-3	12	500	25	12	12	7.3	1.29:1	37	24	94
MAR-6	15	340	-10	-7	-5	2.4	3.00:1	5	7	84
MAR-8	30	430	-4	-3	12	3.5	1.92:1	26	26	86
NE461M02	10	100	30	28	24	5.5	1.25:1	40	38	106
CLC400	15	88	51	16	17	8.7	1.62:1	66	31	96

Table 1. Summary performance table.

less than unity, so the net expected gain is close to 12 dB.

Because MOSFETs are poorly controlled for threshold voltage, you may find it necessary to adjust R7 to yield around 6 volts at Q2's source. R5 should be a 2-watt component, as it dissipates nearly three-quarters of a watt. This particular circuit runs Q2's dissipation somewhat exceeding its rated value. I use a small clip-on heat sink and have not found problems with device reliability.

Pairing the grounded gate input amplifier with a source follower markedly improves the high frequency response over the transformer-coupled grounded gate J310, but with a worse noise figure.

### CLC400 current feedback op amp

National Semiconductor's high-speed current feedback op amp series has interesting applications for wideband RF amplifiers. Anyone interested in these

chips should visit National Semiconductor's Web site [<http://www.national.com>] and download data sheets for members of the CLC family of chips and an excellent series of related Application Notes. In particular, Application Notes OA-7, OA-11, and OA-14 are instructive.

Using a high-speed op amp as an RF amplifier usually exposes an unimpressive noise figure. However, National provides an innovative solution to the noise problem, and I built a 15 dB gain amplifier using a CLC400 chip following the prototype in Application Note OA-14. Some members of the CLC4XX family have higher gain or lower noise figures than the CLC400, so pick the particular amplifier you need to match your requirements.

The circuit has several points of interest. I'll hit the highlights, but a detailed study of National's Application Notes is well worth the time invested.

The key to improving the noise figure is an input step-up transformer; by

judicious selection of a step-up ratio, it's possible to balance noise voltage and noise current contributions in the amplifier. I used a CoilCraft WB1040 1:2 broadband transformer, configured as an autotransformer, to yield a 1:3 voltage step-up. R8 terminates T1 to match the input to 50 ohms. A 1:4 transformer would yield a better noise figure, and additional gain. With a 1:4 transformer, R8 should be changed to 820 ohms. You could, of course, wind your own transformer; 10 quadrafilar turns on a 0.375-inch diameter ferrite toroid using type 43 material should be suitable.

The voltage gain  $A_v$  of the amplifier is determined by the ratio of R7 and R6 in the following formula:  $A_v = (1+R7/R6)$ . Keep the sum of R6 and R7 to be at least 200 ohms, however, as this feedback divider shunts the amplifier output.

Op amps don't like capacitive loads, and R3 is essential to preserve stability when feeding a 50-ohm coaxial cable. Unfortunately, R3 throws away 6 dB of the amplifier's gain, as it forms a voltage divider with the output load. If you were using a CLC400 to directly drive a 50-ohm mixer, for example, through an inch of wire, R3 could likely be omitted and the additional gain recovered. But, as a stand-alone preamplifier to be connected to a receiver through even a short length of coaxial cable, R3 is essential.

Op amps are most often used with

Model	Typical HF Gain (dB)	Max. Frequency (GHz)	Max. Output Power (dBm) @ 1 dB Compression	Noise Figure (dB)	Output IP3 (dBm)	Bias Resistor +12VDC (Ohms)
MAR-1	18.5	1	+1.5	5.5	+14.0	470
MAR-2	12.5	2	+4.5	6.5	+17.0	270
MAR-3	12.5	2	+10.0	6	+23.0	200
MAR-4	8.3	1	+12.5	6.5	+25.5	150
MAR-6	20	2	+2.0	3	+14.5	560
MAR-7	13.5	2	+5.5	5	+19.0	390
MAR-8	32.5	1	+12.5	3.3	+27.0	120

Table 2. MAR amplifier specifications.

Continued on page 58



## Amplifier Testbench Report

*continued from page 17*

equal plus and minus voltage power supplies. Most op amps, however, don't have a "ground" terminal, and it isn't difficult to use a single supply voltage. In this case, the noninverting (+) input pin needs to be held at a voltage equal to halfway between the supply voltage and ground. R5 and R6 are a simple voltage divider to provide  $V_{cc}/2$  bias to pin 3. C2 keeps the DC off T1 and also prevents R8 from loading down the voltage divider. (The input resistance of the CLC400's noninverting input exceeds 200k ohms, so its current doesn't significantly alter the voltage division ratio of R5 and R6.) Since we are using a single power supply, a DC voltage of  $V_{cc}/2$  appears on the output pin and is blocked by C1.