

Fig. 4-1-1. Voice-activated switch and amplifier (NS).

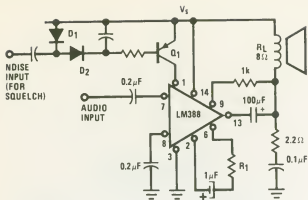

Fig. 4-2. Squelch circuit for FM scanners and handie talkies (NS).

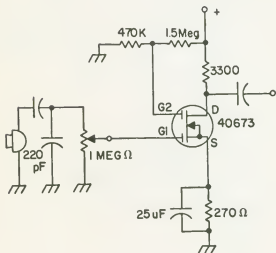
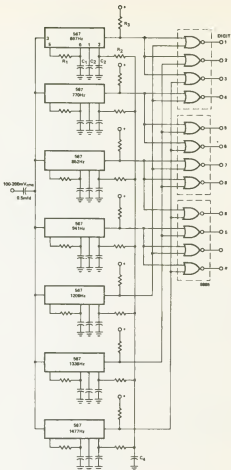

Fig. 4-3. JFET speech amplifiers.



Component Values (Typical)

$R_1$	6.8 to 16K ohm
$R_2$	4.7K ohm
$R_3$	20K ohm
$C_1$	0.10 mfd
$C_2$	1.0 mfd 6V
$C_3$	2.2mfd 6V
$C_4$	250 6V

Fig. 4-4. Touch-Tone® decoder (S).

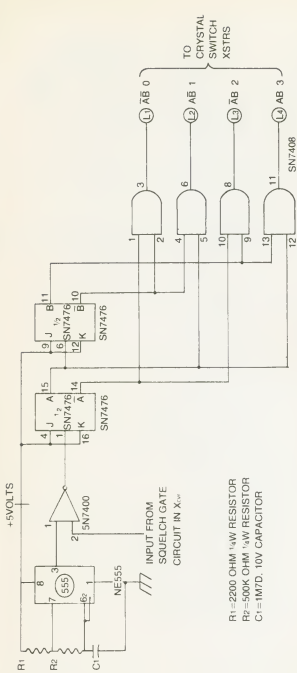

- R1 = 2200 OHM 1/4W RESISTOR
- R2 = 500K OHM 1/4W RESISTOR
- C1 = 1M7D, 10V CAPACITOR

Fig. 4-5. A simple, 4-channel scanner circuit which can be added to a crystal-controlled FM transceiver. The unit sequentially turns on transistors, which then complete the crystal-to-ground connections of the FM rig.

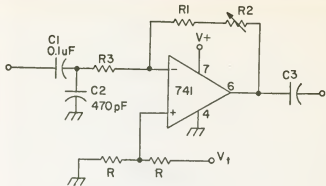

Fig. 4-6. Op amp speech amplifier.

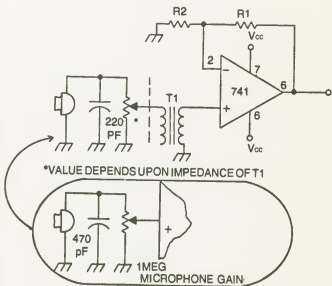

Fig. 4-7. Op-amp speech amplifier.

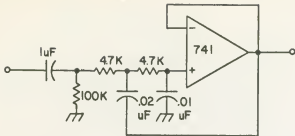

Fig. 4-8. Active-low-pass filter for 3-kHz bandwidth.

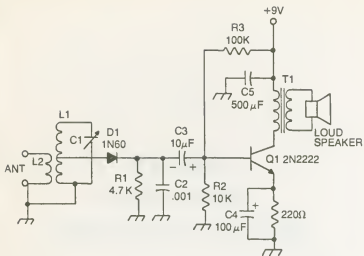

Fig. 5-1. Simple radio receiver uses an audio amplifier at the output of crystal set.

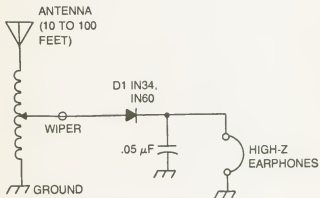

Fig. 5-2. Circuit for a simple crystal set receiver.

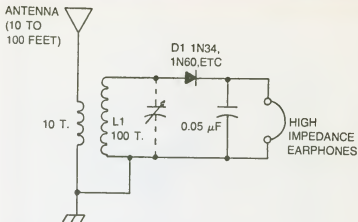

Fig. 5-3. More advanced crystal set receiver.

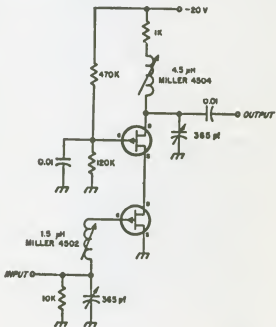

Fig. 5-4. This 30 MHz i-f stage uses two FETs connected in the cascode arrangement to provide 20 dB gain without neutralization; the bandwidth is 4 MHz. Both FETs in this circuit are 2N3819, MPF105 or TIS34. With a negative supply voltage, the 2N4360 would be suitable.



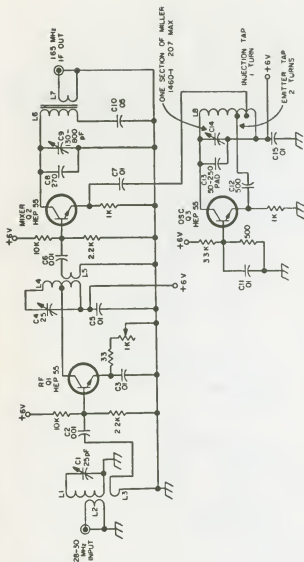

Fig. 5-5. Overall converter schematic. L1, 17 turns, 15 mm OD, 25 mm long; L2, 3 turns on cold end of L1; L4, 11 turns, 8 mm OD, 35 mm long; L5, 2 turns on cold end of L4; L6, 21 turns No. 30 inside cup core from Millen 10C; L7, 4 turns No. 30 wound over L6; L8, 5 turns, 15 mm OD, 8 mm long mixer tap at 1 turn, and emitter tap at 2 turns from ground.

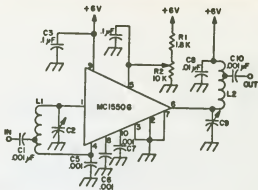

Fig. 5-6. This rf preamplifier is easily adapted to any range under 30 MHz simply by choosing appropriate input and output tuned circuits.

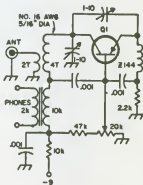
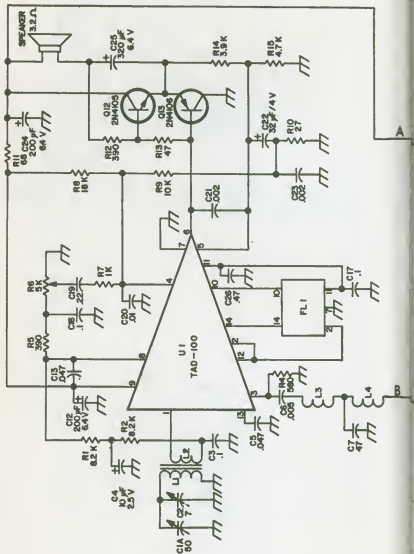
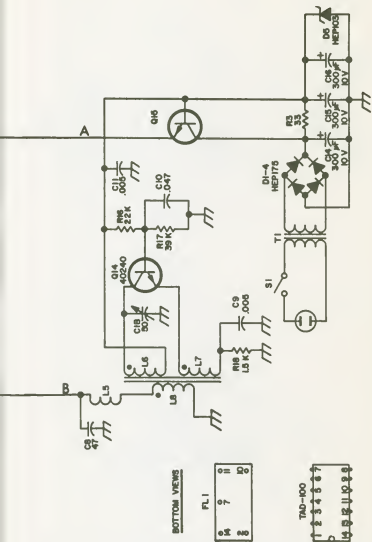

Fig. 5-7. This simple one-transistor superregenerative receiver for two meters may be used for copying many local signals. With the components shown this receiver will tune from about 90 to 150 MHz. It may be used on other frequencies by changing the inductor and capacitor Q1 is a GE-9 or HEP 2.





30 Fig. 5-8. Circuit diagram of the SWL receiver incorporating the TAD-100 IC chip.

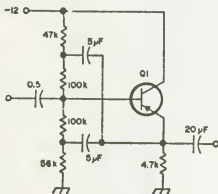
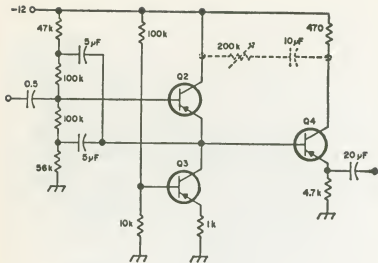
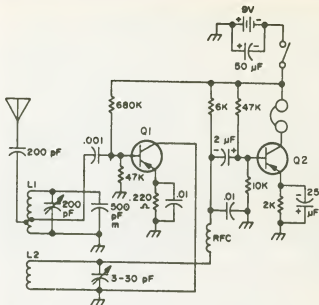

Fig. 5-9. This high-impedance preamplifier provides up to 20 megohms input impedance and has a frequency response from 10 Hz to 220 kHz. Circuit B was developed from circuit A by replacing the emitter resistor in A with Q3 and adding an emitter follower to reduce loading. The input impedance is further increased by the components shown by the dashed line. All transistors are 2N2188, SK3005, GE-9, or HEP 2.



L1-8 TURNS, 3/4 in. DIA  
TAPPED 1 TURN @ 3  
TURNS FROM GROUND. L2-3 1 JRNS

Fig. 5-10. Regenerative receiver for 3.5 MHz optimizes LC ratio for better tuning and controllability. Q1 = 2N370, Q2 = OC70 or 71.

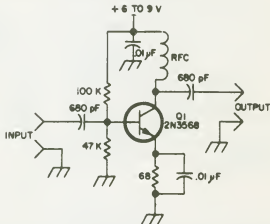

Fig. 5-11. This unit offers 12-15 dB gain on 10m, and about 20 dB or more from 15m and down. All leads should be as short as possible. Building it on a PC board should give good results. Q1 can be any type of transistor. The beta should be around 150+.f should be 60 MHz or better.

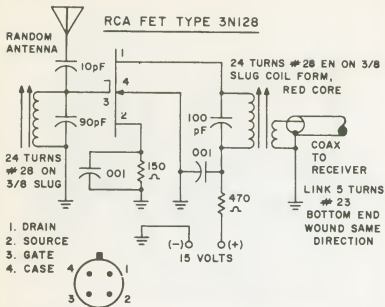

Fig. 5-12. Rf preamplifier for 40 meters (7 MHz) employs FET and yields more than 10 dB gain.

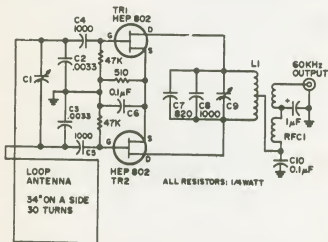

Fig. 5-13. Preamp. C, C9—275—970 pF Elmenco padder 306; C2, C3—0.0033  $\mu$ F Mylar (2200 pF for 6 ft loop); C4, C5, C8—1000 pF dipped silver/mica; C6, C10—0.1  $\mu$ F Centralab CK-104; C7—820 pF dipped silver/mica; L1—3 mH CT. Wound with No. 26 magnet wire approximately 85 turns on an Indiana General Corp. cup core TC7-04-400. Link is 3 turns of insulated wire; RFC1—10 mH Ferrite core rf choke; TR1, TR2—Motorola HEP 802 transistors or RCA 3N128.

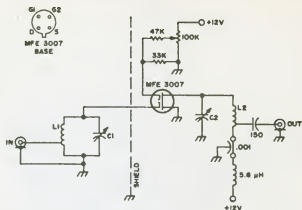

Fig. 5-14. Dual-gate FET preamplifier for 150 MHz range ups received signal strength by 20 dB.

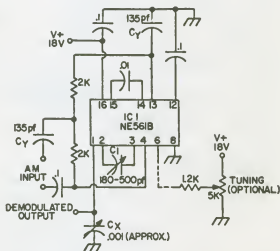
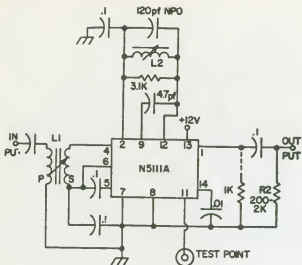

Fig. 5-15. Phase-locked loop allows this AM broadcast-band receiver to be tuned with a 5K pot. Can be adapted to any frequency from 1 to 15 MHz by changing values of  $C_Y$  and  $C_1$ ;  $C_Y = (f_{hi} - f_{lo}) / (f_{hi} \times f_{lo})$ ;  $C_1 = 300 \text{ pF} / f(\text{MHz})$ .





L2 = 1.5-3  $\mu$ H MILLER 9050

Fig. 5-16. FM detector, with 10.7 MHz output, uses phase-locked loop. Part values are shown.

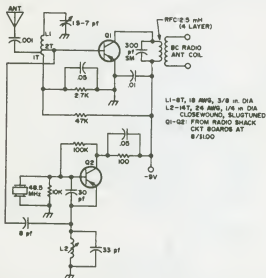
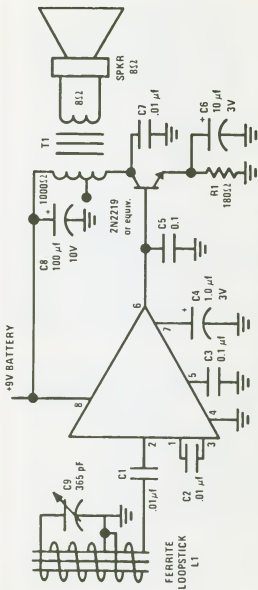

Fig. 5-17. Here is a circuit of a simple 2m converter that works in a pocket AM radio. Since it is crystal controlled, the receiver must tune to a frequency that equals the desired frequency minus  $3 \times 48.5$ . Substitute a different frequency crystal if a strong BC station happens to heterodyne with the desired 2m signal.



- L1 - Ferrite Loopstick - Philmore FF15 (packaged as set of 3 sizes)
- C9 - Sub miniature variable capacitor - Philmore 1949G - 365 pF max.
- T1 - Midget Audio Transformer, 1000 $\Omega$ :8 $\Omega$  - Archer 273-1380 (Radio Shack, Inc.)
- SPKR - 2" PM Speaker, 8 $\Omega$ , 0.1 watt - Philmore TS20

Fig. 5-18. Trf receiver for standard broadcast band uses LM372 integrated circuit.

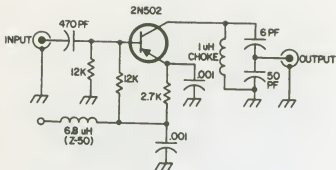

Fig. 5-19. Simple rf preamplifier for 6 meters, TV channel 2 or 3, or any frequency between 50 and 60 MHz. No tuning is required because of broad bandwidth (10 MHz); output impedance is about 50 ohms.

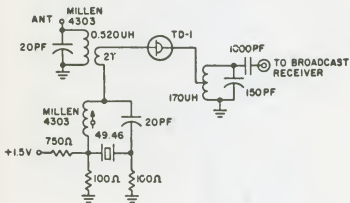

Fig. 5-20. Tunnel-diode converter changes AM broadcast radio to receiver capable of detecting 50 MHz signals.

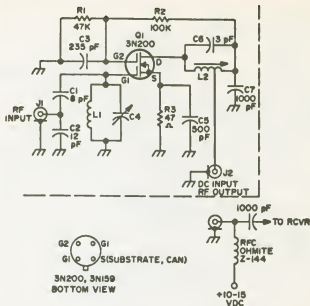

Fig. 5-21. Two-meter preamplifier, MOSFET. C4-5 are button micas and support transistor leads forming resonant circuit. L1 is JFD LC374 tank circuit which contains C1. L2 is 6T 22-gage enamel on 5 mm slug-tuned form, tap at 1 turn. 3N159 will also work in circuit (RTTY Journal, P.O. Box 837, Royal Oak, MI 48068).

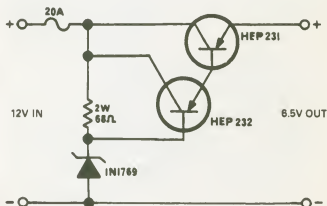

Fig. 5-22. You say you got a real bargain on an old motorcycle FM rig, only to find out it is 6 volt? Fret no more.

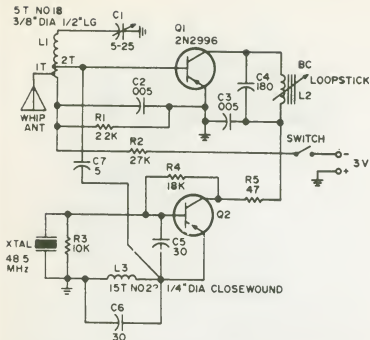

Fig. 5-23. This simple 2-transistor converter tuned in 150 MHz (ham, police, commercial) and requires no direct connection to broadcast-band receiver. Position next to radio receiver.

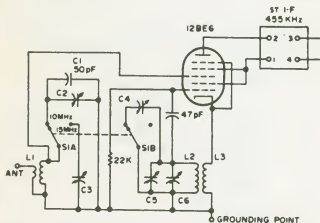
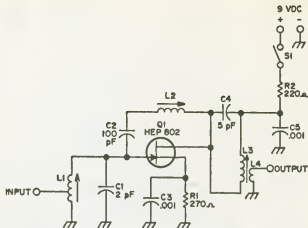

Fig. 5-24. Tunable shortwave converter, designed for receiving WWV on ordinary table radio, allows table radio to receive any signal between 10 and 15 MHz. 15 MHz position must be calibrated with C6 to tune oscillator and C3 to peak rf amplifier; then switch S1 to 10 MHz and tune C4 and C2.



L1 - 5-1/4 TURNS, TAPPED AT 1-1/4 TURNS,  
NO. 26 AWG WIRE.  
L2 - 9-1/2 TURNS, NO. 24 AWG WIRE.  
L3 - 9 TURNS, NO. 26 AWG WIRE.  
L4 - 1-1/4 TURNS, NO. 26 AWG WIRE, AT LOW  
END OF L3.

ALL RESISTORS-1/2W.  
ALL CAPACITORS-10V.

NOTE: ALL LEADS SHOULD BE KEPT AS SHORT AS  
POSSIBLE (PC BOARD IS RECOMMENDED)

Fig. 5-25. Two-meter preamplifier. Very few receivers will not be improved with a preamplifier such as this. The coils are wound on Miller 60A022-4 forms, or any other small brass slug ceramic forms APC board is recommended.

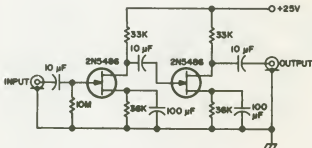
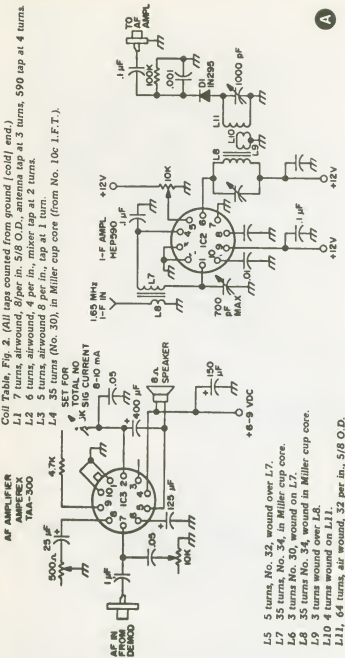
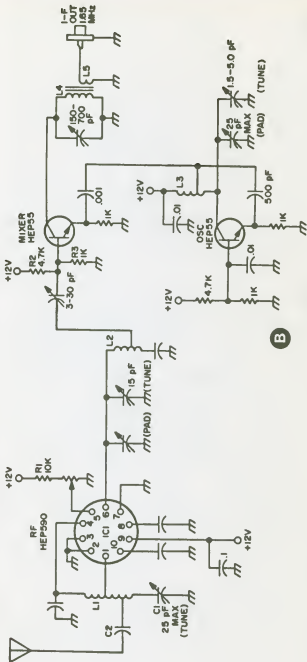

Fig. 5-26. Low-frequency preamp 1 Hz to 50 kHz, voltage gain 400, extremely low noise, all capacitances in  $\mu\text{F}$ , all resistors  $\frac{1}{2}\text{W}$ , transistors 2N5486.

Coil Table, Fig. 2. (All taps counted from ground [cold] end.)  
 L1 7 turns, airwound, 8/per in. 5/8 O.D., antenna tap at 3 turns, 590 tap at 4 turns.  
 L2 6 turns, airwound, 4 per in., mixer tap at 2 turns.  
 L3 5 turns, airwound, 8 per in., tap at 1 turn.  
 L4 35 turns (No. 30), in Miller cup core (from No. 10c I.F.T.).



- L5 5 turns, No. 32, wound over L7.  
 L7 35 turns, No. 34, in Miller cup core.  
 L6 3 turns No. 30, wound on L7.  
 L8 35 turns No. 34, wound in Miller cup core.  
 L9 3 turns wound over L8.  
 L10 4 turns wound on L11.  
 L11, 64 turns, air wound, 32 per in., 5/8 O.D.



**B**

Fig. 5-27. Single-conversion superhetro receiver for 50 MHz uses three HEP 590 Motorola integrated circuits. Unit trades selectivity for extreme sensitivity.



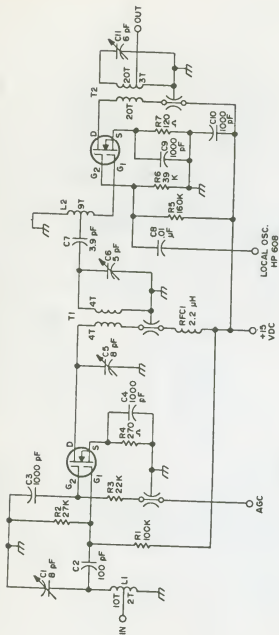

Fig. 5-28. VHF TV tuner using the FT0601 dual-gate MOSFET in RF amplifier and mixer stages.

L1, L2-2M 8 TURNS 16 AWG 6" 13 TURNS 28 AWG  
 C1, C2-2M .5 pF 6M 20 pF E F JOHNSON VARIABLES  
 \*6m = OHMITE Z-50  
 2m = OHMITE Z-144

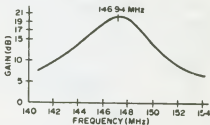
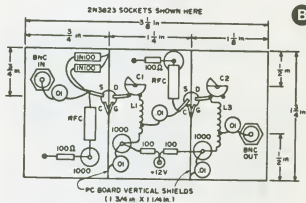
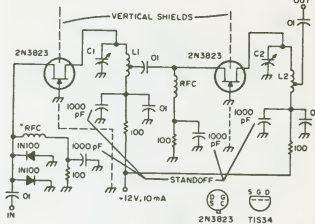
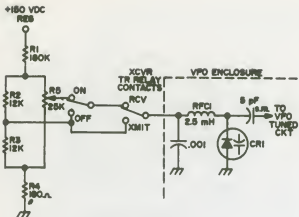
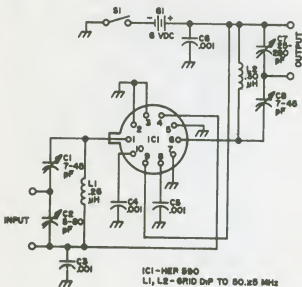

Fig. 5-29. Cascade preamp circuit, using two grounded-gate FETs, provides plenty of rf gain on 6 or 2 meters. Frequency-sensitive values are listed at the upper left portion of the diagram.



**A**



**B**

Fig. 5-30. Six-meter preamp with 30 dB of signal gain and 600 kHz bandwidth. The input and output impedances are matched. AGC may be added to pin 5. For FM use, dip the coils to 52.5 MHz.

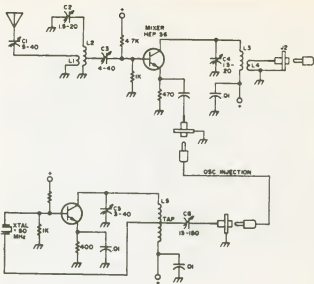

Fig. 5-31. Simple converter allows 170 MHz receiver to be used for reception of 220 MHz signals.

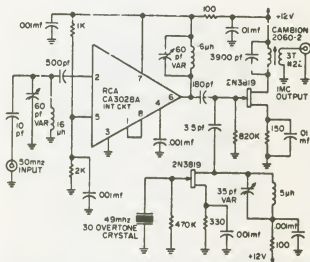

Fig. 5-32. Receiver converter for 50 MHz uses integrated circuit. Output frequency is approximately 1 MHz (center of AM broadcast band).

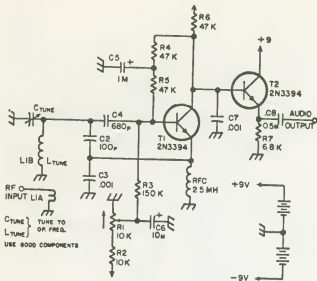

Fig. 5-33. Complete schematic of a good working regenerative detector. Transistor T1 is the actual detector, which operates at very low power levels. T2 is an emitter follower, which copies out the signal with minimum loss.

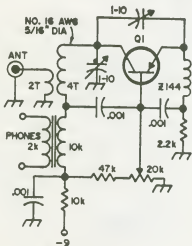

Fig. 5-34. This simple one-transistor superregenerative receiver for 2 meters may be used for copying many local signals. With the components shown, this receiver will tune from about 90 to 150 MHz. It may be used on other frequencies by changing the inductor and capacitor. Q1 is 2N1742, 2N2398, 2N3399, GE-9, or HEP 2.

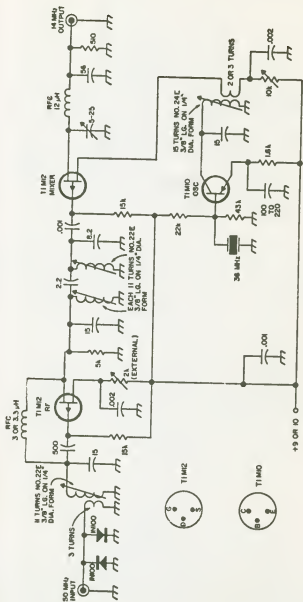
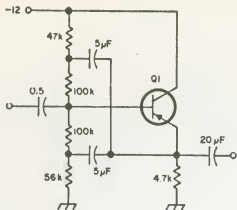
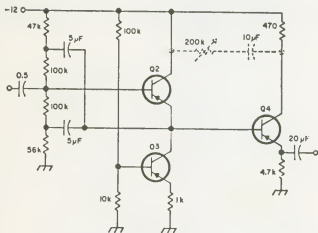

Fig. 5-36. 50 MHz converter using field effect transistor rf amplifier and mixer. The FETs cost about \$1 each. This converter has excellent noise figure and great resistance to cross modulation.



**A**



**B**

Fig. 5-36. This high-impedance preamplifier provides up to 20 megohms input impedance and has a frequency response from 10 Hz to 200 kHz. Circuit B was developed from circuit A by replacing the emitter resistor in A with Q3 and adding an emitter follower to reduce loading. The input impedance is further increased by the components shown by the dashed line. All transistors are 2N2188, SK3005, GE-9, or HEP 2.

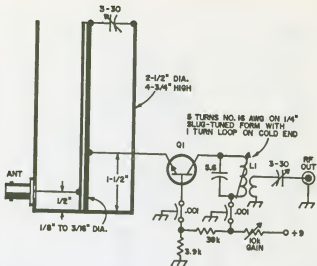
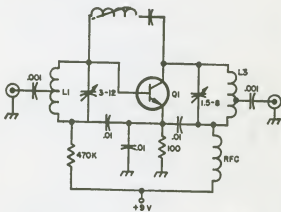

Fig. 5-37. Low-noise 2-meter preamplifier uses a beer can cavity to provide excellent discrimination against nearby kilowatts. Q1 is a 2N3478, 2N3563, 2N3564, 40235, or SK3019.



- L1 3-1/2 TURNS NO. 16, 1/4" DIAM, 1/2" LONG. TAPPED AT CENTER.
- L2 8-1/4 TURNS NO. 24 ON 1/4" SLUG-TUNED FORM.
- L3 8 TURNS NO. 16, 1/8" DIAM, 7/8" LONG. TAPPED ONE TURN FROM COLD END.
- Q1 2N3478, 2N3564, 40235
- RFC 0.84  $\mu$ H (OHMITE Z-220)

Fig. 5-38. Low-noise 220 MHz preamplifier. This circuit will provide extremely high gain with low noise on the 1 1/4 meter band. Neutralization is controlled by inductor L2.



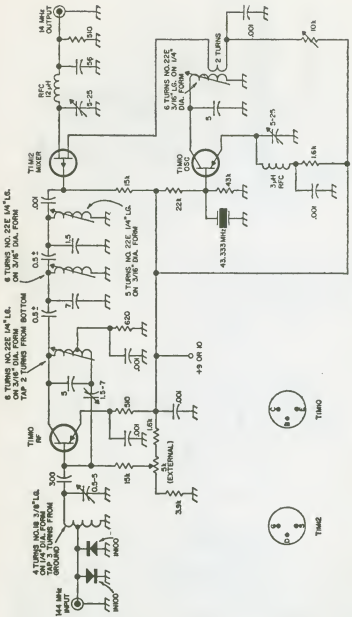

Fig. 5-39. Schematic of low-cost, low-noise, low-cross-modulation 2-meter converter. Note that only the mixer uses an FET; the mixer is responsible for most cross modulation.

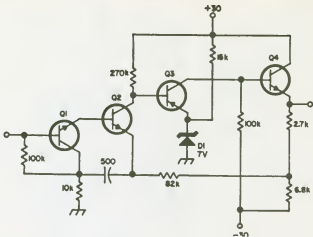

Fig. 5-40. This preamplifier provides 11 dB gain from 0.5 Hz to 2 MHz and has an input impedance of 32 megohms. Transistors Q1, Q2 and Q4 are 2N338, SK3020, or HEP 53; Q3 is a 2N328, GE-2, or HEP 52.

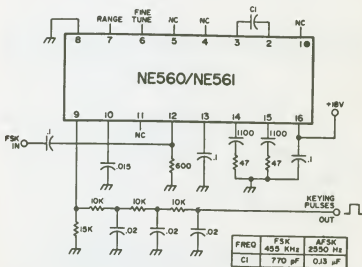

Fig. 5-41. RTTY converter circuit is taken from computer data set applications note; data set is same as AFSK converter, but gets input signal from telephone line and so is not subject to such high levels of interference as is RTTY. Input may be either at i-f or audio frequencies; table shows values of C1 for both cases. Output consists of pulses which may drive a keying circuit for selector magnets.

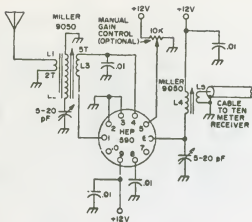
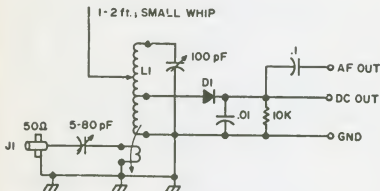

Fig. 5-42. A 28-MHz rf preamplifier uses HEP 590 integrated circuit (Motorola); interconnection to receiver is via coaxial cable.



DI - IN295, TAPPED ON AT 4 TURNS  
 L1 - 8 TURNS, AIRWOUND, 10 PER INCH  
 L2 - 2 TURNS AROUND L1, VARIABLE  
 COUPLING

Fig. 5-43. A diode detector makes a convenient and useful receiver for checking the performance of your postage-stamp transmitter while it's on the bench.

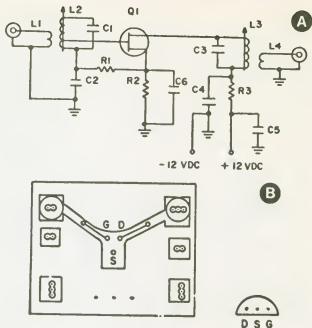
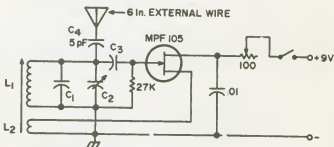
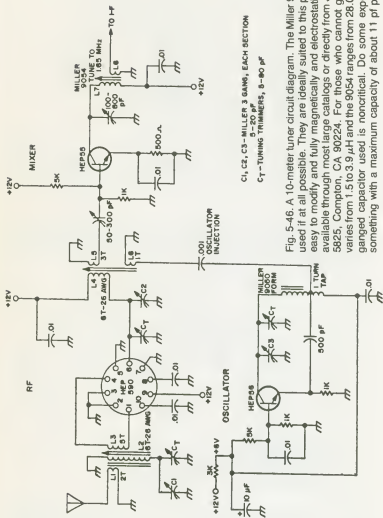

Fig. 5-44. A 2m FM preamp. L1 & L4, 2T No. 22 hookup on cold end of L3; L2 & L3, 3½T No. 16 spaced the dia. L2 & L3 must be wound opposite directions: C1, 10 pF, C2, 470 pF; C3, 10 pF; C4 R1, 220Ω ½W; R2, 370Ω ½W; R3, 22Ω ½W; Q1, Motorola MPF-107 or HEP 802.



- C<sub>1</sub> - SILVER MICA, 51 pF
- C<sub>2</sub> - 3-PLATE MIDGET VAR.
- C<sub>3</sub> - SILVER MICA, 27 pF
- L<sub>1</sub> - 20 TURNS } ON 1/4 in. SLUG-TUNED FORM
- L<sub>2</sub> - 8 TURNS }

Fig. 5-45. The tiny oscillator circuit operates from a standard 9V battery. A small hunk of wire provides an antenna sufficient to insure healthy output for several feet. Placed close to a conventional all-wave receiver, the unit provides sufficient carrier injection for copying single sideband and CW.



C1, C2, C3—MILLER 3 GANG, EACH SECTION  
5–20 pF  
CT—TUNING TRIMMERS, 5–50 pF

Fig. 5-46. A 10-meter tuner circuit diagram. The Miller 9050 and 9054 should be used if at all possible. They are ideally suited to this project because they are easy to modify and fully magnetically and electrostatically shielded. They are available through most large catalogs or directly from J.W. Miller Co., P.O. Box 5825, Compton, CA 90224. For those who cannot get these coils, the 9050 varies from 1.5 to 3.9  $\mu$ H and the 9054 ranges from 28.0 to 60  $\mu$ H. Also, the triple ganged capacitor used is noncritical. Do some experimenting until you get something with a maximum capacity of about 11 pf per section.

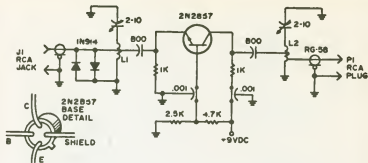

Fig. 5-47. Rf preamplifier for 450 MHz. Insert shows transistor basing.

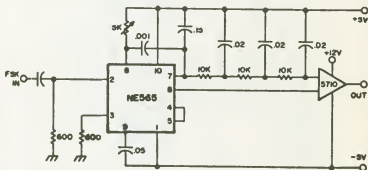

Fig. 5-48. Alternate RTTY circuit uses NE565 IC. Maximum frequency of 565 is 500 kHz. This circuit is designed to drive digital IC devices, and type 5710 voltage comparator is included to adjust output level to values suitable for digital ICs. Pot is for frequency adjustment.

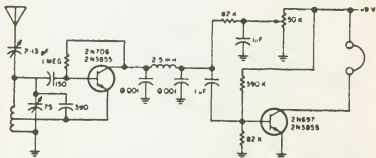

Fig. 5-49. Regenerative receiver for WWV (and other signals in 3.5 MHz region).

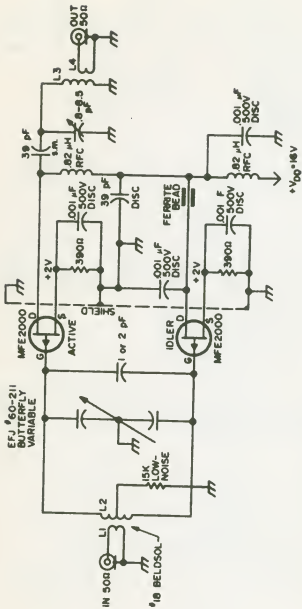

Fig. 5-50. Low noise JFET preamplifier for 2 meters.

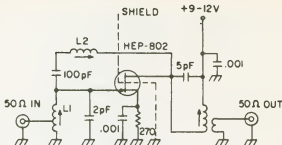

Fig. 5-51. This 150 MHz rf preamplifier uses Motorola FET for true 14 dB gain (after factoring out noise). Coils should be wound on  $\frac{1}{4}$  in. ceramic forms with brass slugs. L1 is 5.5 turns 26-gage tapped 1.25 turns from cold end; L2 is 9.5 turns 34-gage; L3 is 5 turns 26-gage, L4 is 1.5 turns 26-gage wrapped around lower end of L3. Shield well.

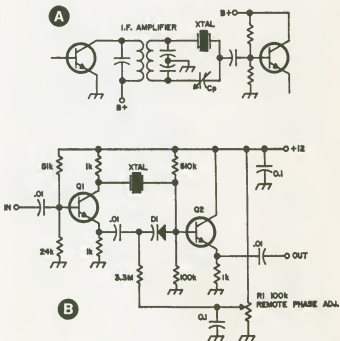

Fig. 5-52. Usually the crystal filter circuit in a receiver (A) must be physically located so that phasing capacitor ( $C_p$ ) is accessible to the front panel. By using the varactor phased filter in B, the crystal may be located in any convenient location. Q1 and Q2 are 2N3478, 2N3564, 2N3707, 40236 or HEP 50; D1 is a 20 pF varactor such as the IN954.



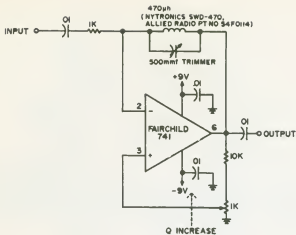

Fig. 5-53. Circuit of the Q-multiplier as constructed for a 455 kHz i-f.

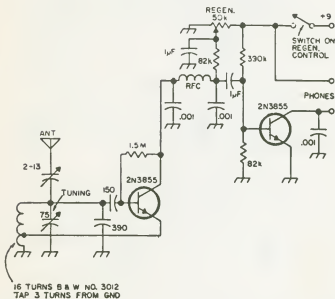

Fig. 5-54. Simple Novice receiver for 80 meters.

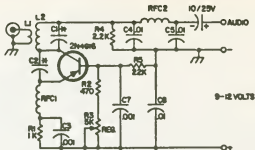

Fig. 5-55. Schematic diagram of superregenerative receiver for the  $\frac{3}{4}$  meter band.

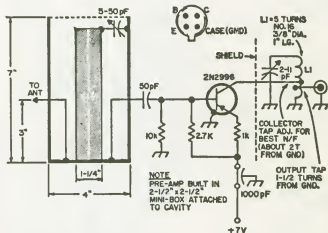

Fig. 5-56. Simple coaxial cavity and transistor preamp for 150 MHz. Emitter should be bypassed with 1000 pF disc.

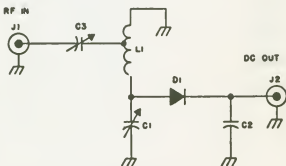

Fig. 5-57. Schematic of diode receiver for 432 MHz.

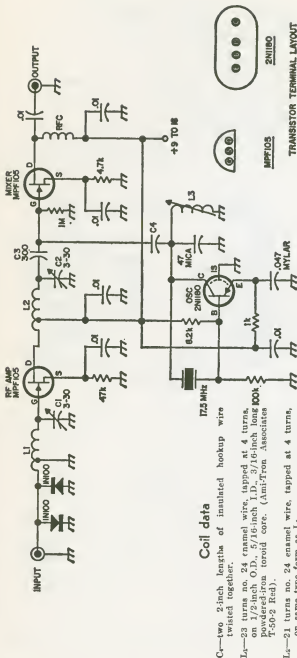

Fig. 5-58. Receiver converter accepts 21-MHz signals and amplified them before converting them to about 3.75 MHz.

## NOTE

ALL RESISTORS 1/4W  
ALL CAPACITORS DISC CERAMIC EXCEPT  
UNLESS OTHERWISE SPECIFIED

TRANSISTOR TERMINAL LAYOUT  
BOTTOM VIEW



MPF7105



2N1180

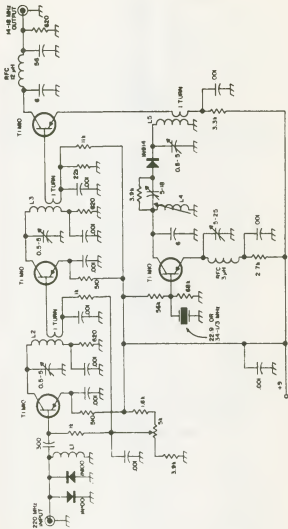

Fig. 5-59. 220 MHz converter built on a 2" x 5" copper-plated board. L1, L2, L3 and L5 are each 4 turns No. 18 wire  $\frac{1}{4}$ " in diameter. L1 is  $\frac{1}{2}$ " long and the other three are  $\frac{3}{8}$ " long. L4 is 11 turns No. 24 enameled on a  $\frac{1}{4}$ " form with a brass slug. The winding is  $\frac{1}{4}$ " long.

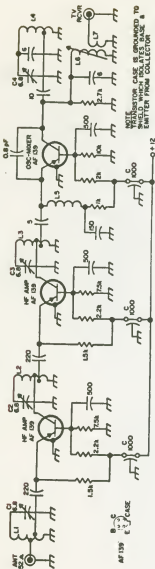
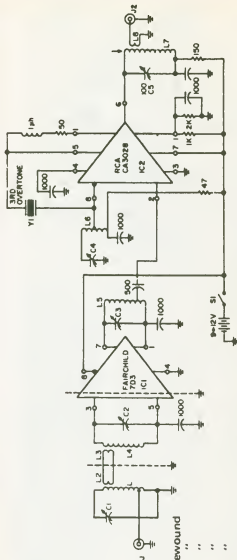

Fig. 5-60. Schematic of simple 440 MHz converter. L1—L4 are quarter-wave trough lines, 5 mm ( $\frac{1}{4}$ " diameter and 68 mm ( $2\frac{11}{16}$ " long. L5 is 3 turns 18-gage 7 mm ( $\frac{5}{16}$ " in diameter. L6 is 7 turns 18-gage on a  $\frac{5}{16}$ " form and L7 is 3 turns on it.



L1 6T ¼" dia closewound

L2 2T ¼" dia

L3 2T ¼" dia

L4 6T ¼" dia.

L5 6T ¼" dia.

Tap 2T

L6 6T ¼" dia

Tap 2T

L7 30T ¼" dia.

L8 3T ¼" dia.

C1 50 pf

C2 50 pf

C3 50 pf

C4 50 pf

C5 100 pf

Y<sub>1</sub> = Xtal 43.5 mhz for 6.5 ic.5 mhz if

R = ¼ watts

C = 50 vdc

C1-4 = 7-45 pf trimmers

Fig. 5-61. Receiver converter for 50 MHz has overall gain of 55 dB; output is difference frequency between crystal and generating frequency.



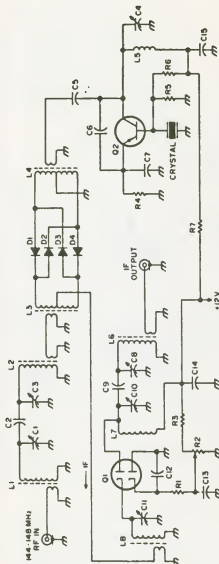

#### PARTS LIST

- C1, C3, C4, C8, C10, C11: 1.7-14.1 pF; EF JOHNSON 189-505-S; 60¢ each.  
 C2, C9: 1.5 pF NPO Ceramic  
 C5: 2.2 pF NPO Ceramic  
 C6: 3 pF Silver Mica  
 C7: 15 pF Silver Mica  
 C12, C13, C14, C15: 1000 pF Disc Ceramic  
 R1: 2.2K  $\frac{1}{4}$ W  
 R2: 50K  $\frac{1}{4}$ W  
 R3: 47K  $\frac{1}{4}$ W  
 R4: 100K  $\frac{1}{4}$ W  
 R5: 2.7K  $\frac{1}{4}$ W  
 R6: 10K  $\frac{1}{4}$ W  
 R7: 1K  $\frac{1}{4}$ W

- L1, L2: PRI 10 turns No. 26 on Micrometals; sec 4 turns No. 26 on cold end.  
 L3, L4: 12 turns No. 34 Tri-filar on Indiana General CF-120-Q1.  
 L5: 7 turns No. 26 on Micrometals  
 L6, L7: 24 turns No. 28 on Micrometals; L7 has a secondary winding of 3 turns.  
 L8: 24 turns No. 28 on Micrometals; primary 7 turns No. 28 on cold end.  
 D1, D2, D3, D4: Hewlett Packard HPA-5082-2805 diodes.  
 Q1: RCA 40602  
 Q2: RCA 2N5187

Fig. 5-63. A 2-meter hot-carrier-diode converter.



Fig. 5-64. Schematic of the 2m converter. L1, L2, and L3—L5 turns No. 18, 0.7 cm diameter airwound, about 2 cm long, tap at one turn, adjust to resonate at 144 MHz. L4—L3 turns hookup wires on L5. L5—L3 turns No. 20, 0.7 cm diameter slug tuned, 1.3 cm long, resonate at 144 MHz. L7—6 turns hookup wire on L6. L8—10 turns No. 24, 0.7 cm diameter slug tuned, resonate at 43 MHz. L9—4 turns No. 24, 0.7 cm diameter slug tuned, resonate at 130 MHz.

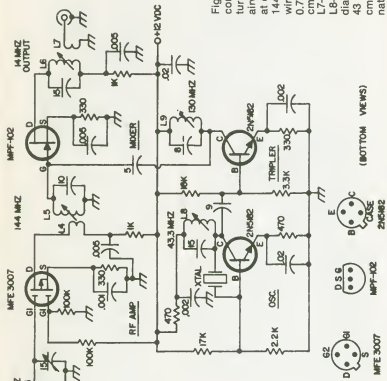

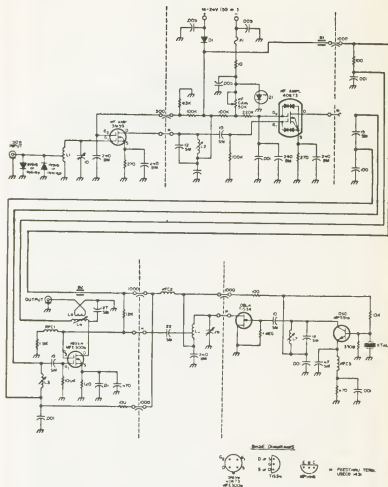

Fig. 5-65. Schematic diagram of 2m converter. Any one of the MOSFET types 3N140, 3N159, or MFE3007 may be substituted for any of the MOSFETs in the schematic. However, a 3N159 will give the lowest noise figure in the first stage. A 40673 should give the best protection against any rf spikes in the second stage. And a MFE3006/MFE3007 should give the best protection against steady, high-voltage rf signals in the mixer stage. All resistors are 1/2-watt carbon, 5%. All fixed capacitors other than SM, BM, or feedthrough types are disc ceramic.