



**“READ”
DIT’S
AND
DAH’S
WITH**

THE MORSE-A-LETTER

Automatically decodes Morse transmissions and displays them alphanumerically, for amateur radio, shortwave, and code training purposes.

NOW YOU can read a message in Morse even if you don't know the code. The “Morse-A-Letter” project presented here automatically converts dahs and dits to alphanumeric characters. With this converter, SWL's can eavesdrop on code exchanges, and prospective and seasoned radio amateurs can have a valuable audio-visual Morse code training and operating aid.

What's more, the Morse-A-Letter features a sophisticated electronic design that ensures accurate and reliable performance. It accepts input signals from a receiver's headphone jack (or from across the speaker leads) and decodes them. The text characters—letters, numerals, and punctuation marks—are then shown sequentially on a LED matrix alphanumeric display. Standard TTL and linear IC's are employed, as well as two ROM's, a MOS character generator, and discrete components. Other features include a built-in monitor loudspeaker, a highly selective active filter, an agc circuit, ASCII output, and simplified, one-control operation. Total project cost is about \$120.

Morse Code Theory. Before examining the Morse-A Letter circuit, let's review the basics of Morse code. Interna-

tional Morse code is a method of encoding Roman letters, Arabic numerals, and punctuation marks so that messages comprising them can be transmitted by radio or wire. Each character is uniquely represented as a group of *elements* taking the form of audio tones or silences (spaces) of prescribed length.

The tone elements are called dits and dahs, and the spaces consist of element spaces, character spaces, and word spaces. The dits and dahs within a character are separated by element spaces. (For example, the letter *s* is represented by the sequence: dit, element space, dit, element space, dit.) Whole characters and words are separated by character and word spaces, respectively. The normalized, ideal element lengths are shown in Fig. 1. For English text, the common method for determining the rate of transmission is expressed by the formula: code speed (in words per minute) equals dits per minute divided by 25.

Those familiar with Baudot or ASCII codes will consider Morse rather primitive. Each element is of variable length, and there is no provision for parity checking or error correction. Nevertheless, Morse is widely used by commercial press and ship-to-shore stations, the

military, and amateur radio operators. This is partly due to the simplicity of the equipment required. Virtually any transmitter with provision for keying the r-f carrier on and off can be used for CW (continuous wave, or Morse code) work.

Other factors favoring Morse include its inherent efficiency. Just as much information is contained in the spaces as in the dits and dahs. Therefore, the amount of energy required to transmit a message is reduced by about 50 percent. Additional efficiency results from characters of variable length, from one to eleven elements. The most common letters in English text are assigned the shortest code.

The factors which make Morse efficient also make it difficult to decode. Atmospheric or man-made noise can occur, particularly during spaces (when no signal is present). This can introduce spurious elements. The fact that characters are not uniform in length means that character length is difficult to predict. However, the things that affect decoding most are the physical and psychological factors that influence manual sending quality. Fatigue, inattentiveness, and forgetfulness on the part of the sender cause randomness, unpredictability, and inaccuracy in element length.

The foregoing makes it clear that a Morse decoder must function with a high degree of accuracy for it to be effective. The Morse-A-Letter has been designed to meet this need by utilizing narrow filters for noise rejection, agc for fading compensation, and circuitry that allows for sending-speed variations.

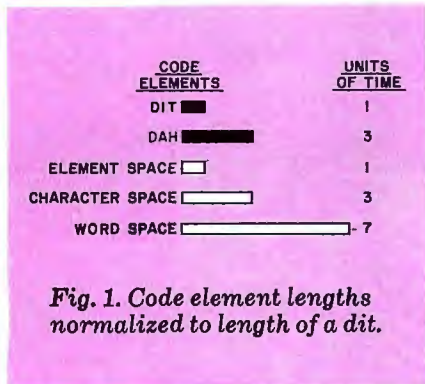

System Analysis. A block diagram of the Morse-A-Letter is shown in Fig. 2, with the complete schematic in Fig. 3. A selector switch at the system's input allows selection of either the internal 1100-Hz oscillator for code practice or an external audio signal from a radio receiver. The signal applied to the input is conditioned by an agc stage whose gain is determined by a voltage fed back from a succeeding stage. The output of the agc circuit feeds a two-stage narrow bandpass filter whose response is centered at 1100 Hz. An op amp and a speaker are connected to the filter output for monitoring purposes.

The filter output also drives a full-wave rectifier which demodulates the audio tones so that only low voltages or high voltages are generated. The demodulated signal is applied to two stages simultaneously. It is smoothed and filtered into the control signal of the agc loop, and is also "squared up" by a two-stage Schmitt trigger. At the output of the Schmitt trigger, a logic one corresponds to a key down condition, and a logic zero to a key up condition. Clean, constant-level Morse signals are thus available for processing by the decoding circuitry.

The processed Morse is then applied to two counters, called the key-up and key-down counters. One counter, but not both, will count, depending on whether the key is up or down. These key-condition counters operate at a rate dependent on the frequency of an internal, adjustable clock which must match the input code speed. However, the clock rate can be off by as much as $\pm 50\%$ and still provide solid copy.

Each time the key-up counter detects

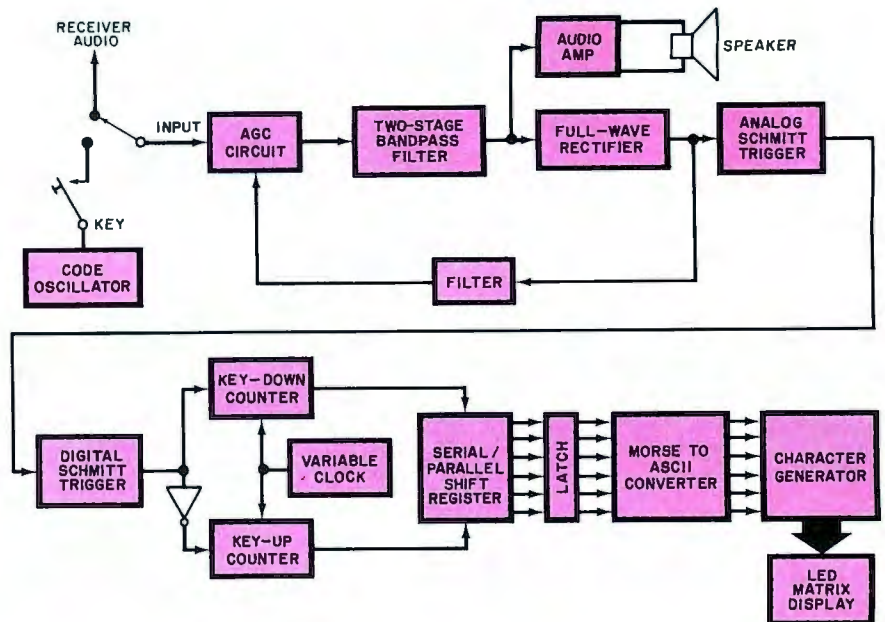

Fig. 2. Block diagram of the Morse-A-Letter shows how incoming code is converted to visual display.

PARTS LIST

C1—1- μ F, 15-volt tantalum capacitor
 C2 through C7, C18—0.1- μ F, $\pm 10\%$ Mylar capacitor
 C8—150- μ F, 15-volt upright electrolytic capacitor
 C9—6.8- μ F, 15-volt tantalum capacitor
 C10—0.01- μ F Mylar capacitor
 C11, C12, C13, C15, C17—0.1- μ F disc ceramic capacitor
 C14—0.15- μ F Mylar capacitor
 C16—470-pF silver mica capacitor
 C19, C20—2.2- μ F, 15-volt tantalum capacitor
 D1, D2—1N914 diode
 D3, D4, D5, D7, D8—1N270 diode
 D6—4.7-volt, 1-watt zener diode (1N4732A or equivalent)
 DIS1—MAN-2 5 \times 7 LED matrix display
 IC1, IC2—747A dual operational amplifier IC
 IC3—741 operational amplifier IC (8-pin mini-DIP)
 IC4, IC7, IC21—555 timer IC
 IC5—7413 dual NAND Schmitt trigger IC
 IC6, IC8, IC20—74161 synchronous four-bit counter IC
 IC9—74121 monostable multivibrator IC
 IC10, IC11—7495 four-bit right-shift/left-shift register IC
 IC12, IC14—7475 quadruple bistable latch IC
 IC13—7404 hex inverter IC
 IC15, IC16—8223 256-bit bipolar programmable Read-Only Memory IC
 IC17—2513 MOS character generator IC
 IC18—7407 hex buffer/driver IC
 IC19—74145 decoder/driver IC
 LED1, LED2—20-mA miniature LED
 Q1—2N3823 n-channel JFET
 Q2, Q3—2N2222 npn switching transistor
 The following fixed resistors are $\frac{1}{4}$ -watt, 10% tolerance unless otherwise specified.
 R1—4700 ohms
 R2, R18, R19—10,000 ohms
 R3, R12—200 ohms, 5% tolerance

R4, R5, R13, R14, R24—2200 ohms, 5% tolerance
 R6, R15—180 ohms, 5% tolerance
 R7, R16—100,000 ohms
 R8, R10—39,000 ohms
 R9, R22, R35 through R40—1000 ohms
 R11, R34—470 ohms
 R17, R20—1500 ohms
 R23—68,000 ohms
 R25—47 ohms
 R26, R32—47,000 ohms
 R28, R30—27,000 ohms
 R29, R31, R42 through R46—330 ohms
 R33, R41—5600 ohms
 R21—5000-ohm printed circuit trimmer potentiometer
 R27—100,000-ohm printed circuit trimmer potentiometer
 R47—100,000-ohm linear taper potentiometer
 S1—Spdt toggle switch
 Misc.—Printed circuit board, 22-pin edge connectors (2, optional), suitable enclosure, plastic bezel, IC sockets or Molex Soldercons, small 8-ohm dynamic speaker, suitable jacks, standoff spacers, rubber grommets, brackets, machine hardware, hookup wire, shielded cable, etc.
 Note—The following items are available from Select Circuits, 1411 Lonsdale Road, Columbus, OH 43227: Complete kit of parts including etched and drilled G-10 glass epoxy printed circuit board, power supply components and all parts except chassis and enclosure (MAL-1 PCK), \$109.95; Etched and drilled G-10 printed circuit board (MAL-1), \$17.95; Preprogrammed Letter ROM (LET-15), \$6.00; Preprogrammed Numeral ROM (NUM-16) \$6.00. Prices of ROM's include shipping charges if ordered with pc board MAL-1. If ordered separately, add \$0.50 each for shipping charges. MAL-1 and MAL-1 PCK prices include shipping charges within the continental U.S. Ohio residents add 4% sales tax.

Fig. 3. Complete schematic of the Morse-A-Leter circuit.

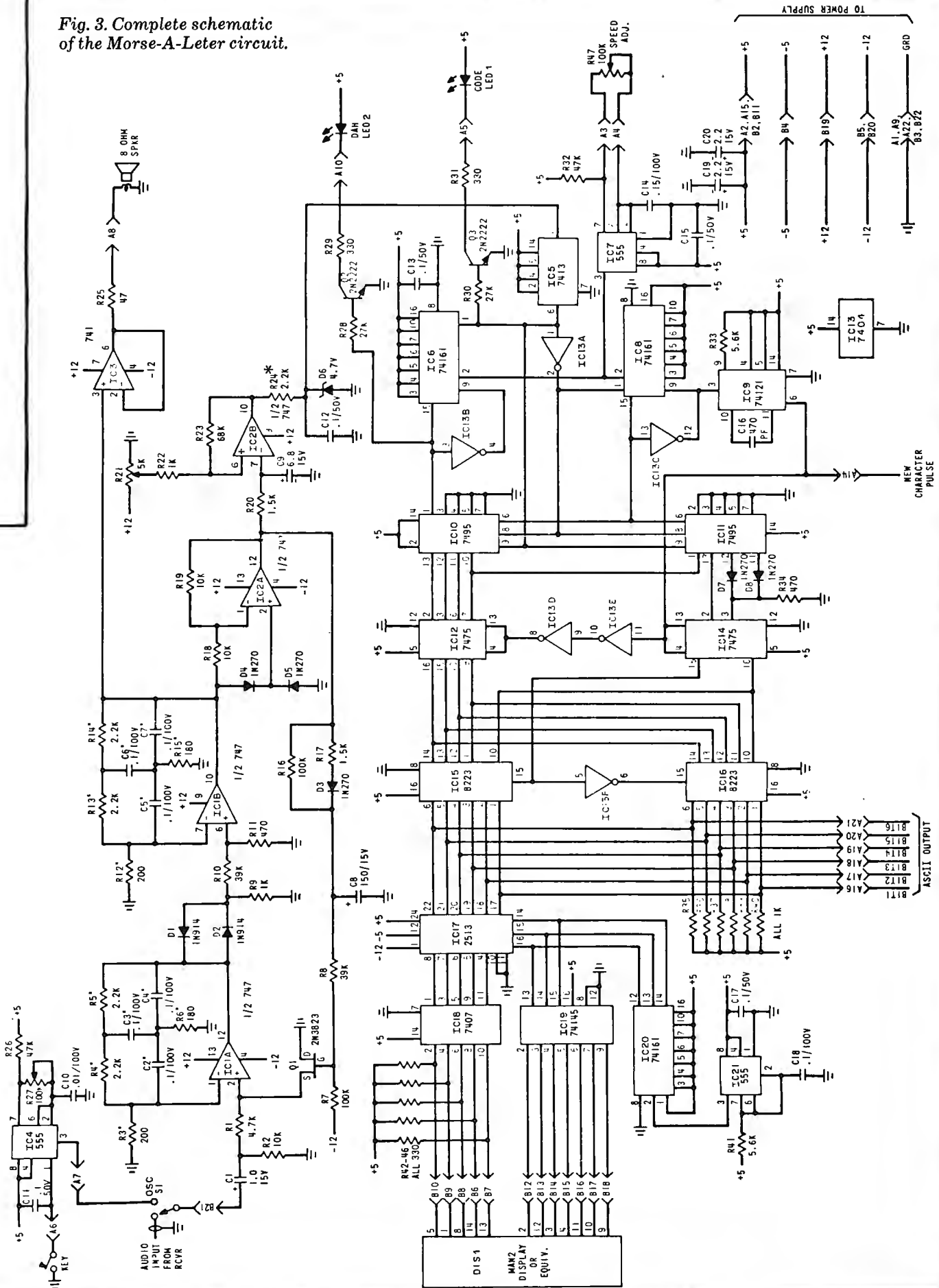

an element space (a condition which occurs whenever the key-up counter detects less than 15 clock pulses), it serially transfers a logic 0 or 1 to the next stage, an eight-bit serial/parallel shift register. This shift register is always initialized to the binary word 00000001 so that the beginning of each Morse character will be uniquely decodable. The transfer of a logic 0 or 1 to the shift register is determined by the condition of the key-down counter. This counter differentiates between dits and dahs. If the key-down counter counts more than 15 clock pulses, the tone element is a dah. Otherwise, it is a dit. This simple detection scheme has been found to be very efficient and reliable in actual use.

This procedure continues until the key-up counter detects a space longer than an element space. At this point, it is known that a complete character has been sent, and the unique binary code present in the serial/parallel shift register is parallel-transferred to a latch for storage and ASCII encoding. The key-condition counters and shift register are then re-initialized and ready for the next Morse character.

Read-only memories (ROM's) are used to convert the binary code in the latch into ASCII. One ROM encodes letters, and another handles numerals and special characters. Conventional character-generating techniques are then employed for the display of the appropriate alphanumeric symbol.

A power supply circuit for the project is shown in Fig. 4. Current demand on the +5-volt supply is about 600 mA; while the -5-volt demand is only about 10 mA. Each 12-volt supply provides about 40 mA.

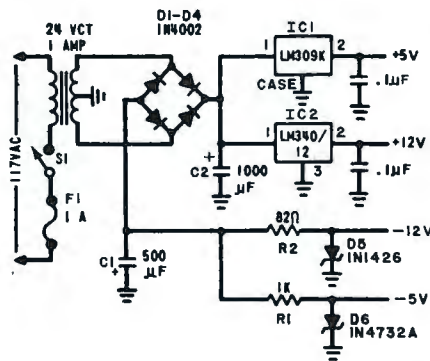

Fig. 4. Schematic of power supply.

POWER SUPPLY PARTS LIST

- C1—500- μ F, 35-volt electrolytic capacitor
- C2—1000- μ F, 35-volt electrolytic capacitor
- C3, C4—0.1- μ F disc ceramic capacitor
- D1 through D4—1N4002 rectifier diode
- D5—12-volt, 1-watt zener diode (1N1426 or equivalent)
- D6—4.7-volt, 1-watt zener diode (1N4732A or equivalent)
- F1—1-ampere fuse
- IC1—LM309K 5-volt regulator IC
- IC2—LM340/12 12-volt regulator IC
- R1—1000-ohm, 10%, 1/4-watt resistor
- R2—82-ohm, 10%, 1-watt resistor
- S1—Spst switch
- T1—24-volt center tapped, 1-ampere transformer.
- Misc.—Terminal strips, silicone grease, line cord and strain relief, fuseholder, hookup wire, solder, machine hardware, etc.

Construction. The Morse-A-Letter is most easily constructed on a printed-circuit board. The etching and drilling and parts placement guides for a board are shown in Fig. 5. Be sure to use a small-tipped, low-wattage soldering iron and Molex Soldercons or IC sockets. Start by inserting the smallest components first, gradually working up to the larger

items. For example, install all the jumpers, then the 1/4-watt resistors, followed by the diodes, etc. Naturally, you should follow good soldering practices.

Note that DIS1, S1, S2, LED1, LED2, the monitor speaker, jacks and sockets, and the power supply are not mounted on the pc board. Rather, provisions are made for using 22-pin edge connectors for interfacing. (See Table 1 for connector terminal number assignments.) Off-board components should be mounted in a convenient manner on a suitable project enclosure.

The ROM's (IC15 and IC16) must be properly programmed. The truth tables are given in Tables 2 and 3. In POPULAR ELECTRONICS, July 1975, there's an article entitled "How to Program Read-Only Memories" that describes the required procedure. However, some parts sources will program the 8223's if you include the truth tables with your order. The kit supplier (see Parts List) also offers pre-programmed ROM's.

Install the IC's in their sockets, taking the usual precautions when handling MOS devices such as IC17. Apply power to the project.

Internal Adjustments. Two potentiometer adjustments must be made. The first determines the pitch of the code practice oscillator. Plug a telegraph key into the key jack and put S1 in the osc position. Depress the key and adjust R27 for the loudest output from the speaker. An aural adjustment is adequate. The pitch of the oscillator output will be approximately 1100 Hz (the center frequency of the active filter).

The second adjustment sets the threshold of analog Schmitt trigger

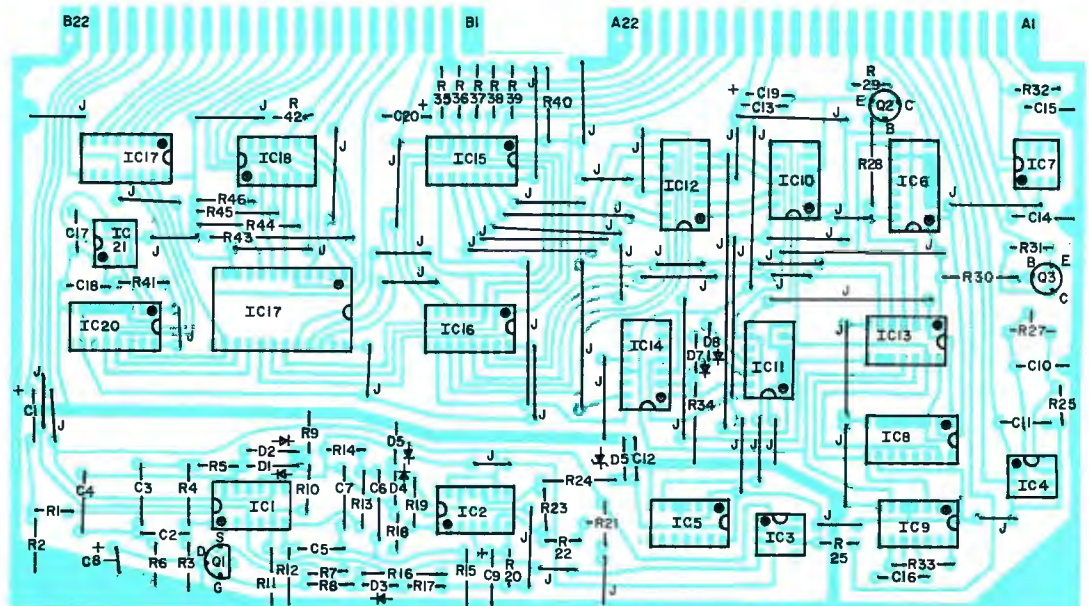
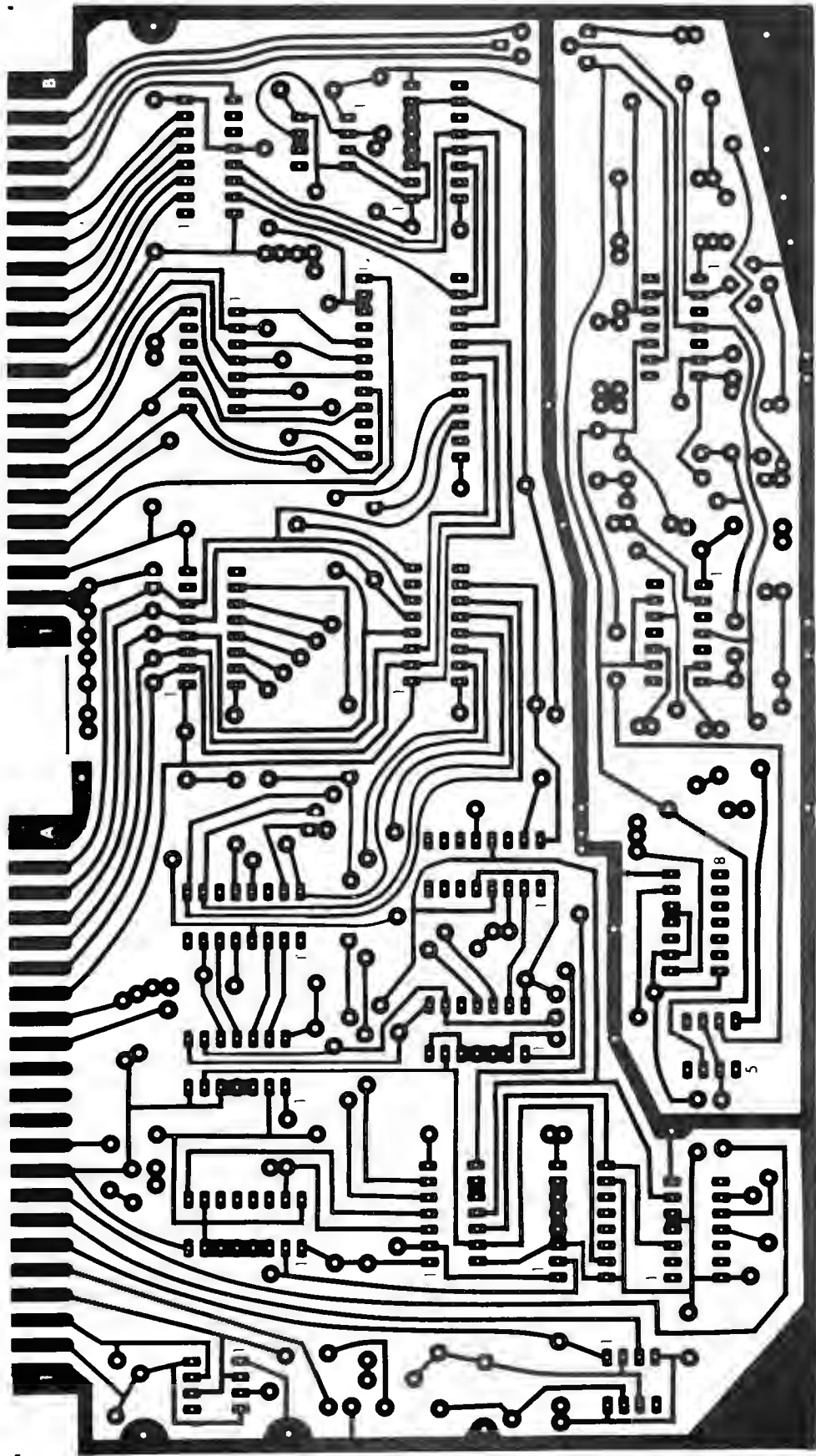

Fig. 5. Component placement guide is at right. Etching and drilling guide for pc board opposite.



IC2B. Connect the audio output of a shortwave receiver equipped with a BFO to the audio input jack of the Morse-A-Letter. You can take the audio signal from across the speaker leads or from the headphone jack. Use shielded cable for the interconnection.

The best way to make the adjustment is with a dc-coupled oscilloscope. Connect the receiver to the Morse-A-Letter audio input, and put *S1* in the RCVR mode. Carefully tune in a signal so that its pitch is in the center of the filter pass-band. When it is properly tuned in, the CODE LED (*LED1*) will glow. The signal will also be heard through the small monitor speaker. Note that the Morse-A-Letter's input stage is very sensitive and, therefore, does *not* require a large audio signal. Back down on the audio gain if you have trouble getting a signal properly tuned in. Connect a probe from the oscilloscope's vertical amplifier to pin 7 of *IC2*. The signal at this point should follow the code, with zero voltage when the key is up (spaces) and about four volts when the key is down (tone elements). The waveform will appear rounded or low-pass filtered.

Decide where you would like *IC2B*'s threshold to be, based on your observations of the waveform and its response to QRM (interference from other stations), QRN (interference from static), etc. Then place the scope probe on pin 6 of *IC2* and adjust *R21* so that the voltage at this point is the same magnitude as the chosen signal threshold. You'll observe that this voltage will not remain at exactly the same level, but will shift a small amount as the Schmitt trigger follows the code.

If a scope is not available, you can still make an approximate adjustment. Tune in a suitable signal as described earlier. Measure the key-up and key-down voltages at pin 7 of *IC2* with a high-impedance (20,000 ohm/volt or more) voltmeter. The key-up voltage should be zero and the key-down voltage about four volts. Then measure the voltage at pin 6 of *IC2*. Adjust *R21* so that this voltage is about 40% of the key-down voltage at pin 7. This technique should produce satisfactory results. There is nothing "magical" about the 40% figure. Experiment with the setting of *R21*.

If the Morse-A-Letter is to be used solely as a code practice device, the adjustment of *R21* should be made by either of the methods described, using the internal code practice oscillator as the signal source. Of course, the oscillator output frequency must first be set at the center of the active filter's passband.

CIRCUIT DETAILS

As shown in Fig. 3, a selective bandpass filter comprises *IC1A* and *IC1B* and the associated components. It provides a bandwidth of about 100 Hz and a degree of threshold limiting due to *D1* and *D2*. The filter forms the forward portion of the agc loop which automatically provides variable gain for operation during periods of signal fading. The agc loop is completed by full-wave detection of the audio output of *IC1B* by *IC2A*, *D4*, *D5* and the associated resistors. The resulting dc voltage controls the bias of *Q1*, a FET acting as a variable resistor. Capacitor *C8*, diode *D3*, and resistors *R16* and *R17* provide independent attack and decay times for the agc circuit.

Op amp *IC2B* is an analog Schmitt trigger which squares up the output of *IC2A*. The trigger's threshold is fixed after initial adjustment of *R21* because the agc loop maintains almost constant signal levels at this point even under extreme variations in input levels. The output level of *IC2B* is made TTL-compatible by zener diode *D6*. Op amp *IC3* is the remaining analog stage. It is a voltage follower that passes the band-pass filter output to a small speaker, providing adequate volume for monitoring purposes. A 555 free-running timer, *IC4*, is used as a code practice oscillator. Its output is fed to the band-pass filter when switch *S1* is in the osc position.

The input to the "digital" section of the Morse-A-Letter (*IC5*) is a 7413 Schmitt trigger IC. It provides additional noise immunity and sharp rise and fall times for the succeeding stages. The output of *IC5* is used to enable or disable *IC6* and *IC8*, the 4-bit binary key-up and key-down counters, respectively. Both counters are wired to count to 15 and then latch up.

Assume that the key has been up for a few seconds. Key-down counter *IC6* is being held clear by the input signal. Key-up counter *IC8* has counted to 15 and latched. Thus, pin 15 (the carry output) of the key-up counter is at logic one, putting shift register *IC10IC11* in the parallel mode. (These two four-bit shift registers are wired together to act as one eight-bit register.)

Now assume the key is depressed. The word 00000001 is parallel-loaded into *IC10IC11* and *IC8* is cleared, putting the shift register in the serial mode. If *SPEED* control *R47*—which governs the clock rate of *IC7*—is set properly, *IC6* will count less than 15 clock pulses when a dit is sent, or latch at 15 when a dah is sent. Next, assume the key is released. The data at pin 15 of *IC6* is serially entered into the shift register and key-up counter *IC8* is allowed to count the length of the space. If it is short (meaning the character has not been

completed), pin 15 of *IC8* will remain low and the shift register will remain in the serial mode. The stages will now process the next dit or dah.

This procedure will continue until the character is completed. The data in the shift register will then be equivalent to the Morse sent, with a dit a logic 0 and a dah a logic 1. Note, however, that a leading logic 1 has been inserted to identify the start of the character in the register. This is important because Morse is a variable length code. For example, the letter *A* (dit dah) will appear as 00000101 while a *U* (dit dit dah) will appear as 00001001. The leading (left-most) logic 1 is needed to eliminate the ambiguity that would otherwise exist.

A long space occurs at the end of a character which allows *IC8* to count to 15 and latch. This causes *IC9*, a one shot, to generate a new character pulse which will load the data from shift register *IC10IC11* into latches *IC12* and *IC14*. The data is held there and used to drive the display circuitry until the next character is completed.

If a letter is being decoded, only the first five bits are really needed. If a numeral or punctuation mark is received, six or seven bits are required. However, any punctuation mark or numeral is uniquely described by the five low-order bits in the register. If the sixth or seventh bit is a 1, the character is a numeral or punctuation mark. If the sixth and seventh bits are 0's, the character is a letter. So these bits are OR'ed together by *D7*, *D8*, and *R34* before being entered into the latches. The resulting signal selects either the letter ROM (*IC15*) or the numeral/punctuation ROM (*IC16*) to decode the remaining five bits.

The output of the ROM's is standard six-bit ASCII. This ASCII is used to drive *IC17*, a 2513 character generator, and is also available for use with a TV typewriter. (A "new character" pulse output is provided for CRT display.) Decoders and drivers *IC18-20* activate a MAN-2 LED matrix (*DIS1*) that provides alphanumeric display of the transmitted Morse characters. Integrated circuit *IC21* provides clock pulses for the decoder and driver stages. Two discrete LED's are also used for monitoring purposes.

The CODE *LED1* is driven by the Schmitt trigger output. This LED glows when the Morse signal is properly tuned in and is reaching the Schmitt trigger. The DAH *LED2* is driven by the data signal at pin 15 of key-down counter *IC6*. This LED glows when the transmitted tone element is longer than 15 clock pulses. A simple means of determining when *SPEED* (clock rate) control *R47* is properly set is thereby provided.

**TABLE 2
TRUTH TABLE FOR IC15**

Character	Input					Output					
	A ₀	A ₁	A ₂	A ₃	A ₄	B ₀	B ₁	B ₂	B ₃	B ₄	B ₅
A	0	0	1	0	1	1	0	0	0	0	0
B	1	1	0	0	0	0	1	0	0	0	0
C	1	1	0	1	0	1	1	0	0	0	0
D	0	1	1	0	0	0	0	1	0	0	0
E	0	0	0	1	0	1	0	1	0	0	0
F	1	0	0	1	0	0	1	1	0	0	0
G	0	1	1	1	0	1	1	1	0	0	0
H	1	0	0	0	0	0	0	0	1	0	0
I	0	0	1	0	0	1	0	0	1	0	0
J	1	0	1	1	1	0	1	0	1	0	0
K	0	1	1	0	1	1	1	0	1	0	0
L	1	0	1	0	0	0	0	1	1	0	0
M	0	0	1	1	1	1	0	1	1	0	0
N	0	0	1	1	0	0	1	1	1	0	0
O	0	1	1	1	1	1	1	1	1	0	0
P	1	0	1	1	0	0	0	0	0	1	0
Q	1	1	1	0	1	1	0	0	0	1	0
R	0	1	0	1	0	0	1	0	0	1	0
S	0	1	0	0	0	1	1	0	0	1	0
T	0	0	0	1	1	0	0	1	0	1	0
U	0	1	0	0	1	1	0	1	0	1	0
V	1	0	0	0	1	0	1	1	0	1	0
W	0	1	0	1	1	1	1	1	0	1	0
X	1	1	0	0	1	0	0	0	1	1	0
Y	1	1	0	1	1	1	0	0	1	1	0
Z	1	1	1	0	0	0	1	0	1	1	0

**TABLE 1
CONNECTOR TERMINAL
ASSIGNMENTS**

- A1—Ground
- A2—+5 Volts
- A3—To speed pot R47
- A4—To speed pot R47
- A5—To "CODE" LED
- A6—To key
- A7—Oscillator output
(to RCVR/OSC select switch)
- A8—To speaker
- A9—Ground
- A10—To "DAH" LED
- A11—No connection
- A12—No connection
- A13—No connection
- A14—New character pulse
- A15—+5 Volts
- A16—ASCII output bit 1
- A17—ASCII output bit 2
- A18—ASCII output bit 3
- A19—ASCII output bit 4
- A20—ASCII output bit 5
- A21—ASCII output bit 6
- A22—Ground

- B1—No connection
- B2—+5 Volts
- B3—Ground
- B4—-5 Volts
- B5—-12 Volts
- B6—To MAN 2 (DIS1) pin 14
- B7—To MAN 2 (DIS1) pin 13
- B8—To MAN 2 (DIS1) pin 8
- B9—To MAN 2 (DIS1) pin 1
- B10—To MAN 2 (DIS1) pin 5
- B11—+5 Volts
- B12—To MAN 2 (DIS1) pin 2
- B13—To MAN 2 (DIS1) pin 12
- B14—To MAN 2 (DIS1) pin 3
- B15—To MAN 2 (DIS1) pin 4
- B16—To MAN 2 (DIS1) pin 11
- B17—To MAN 2 (DIS1) pin 10
- B18—To MAN 2 (DIS1) pin 9
- B19—+12 Volts
- B20—-12 Volts
- B21—Audio input from receiver
- B22—Ground

**TABLE 3
TRUTH TABLE FOR IC16**

Character	Input					Output					
	A ₀	A ₁	A ₂	A ₃	A ₄	B ₀	B ₁	B ₂	B ₃	B ₄	B ₅
0	1	1	1	1	1	0	0	0	0	1	1
1	0	1	1	1	1	1	0	0	0	1	1
2	0	0	1	1	1	0	1	0	0	1	1
3	0	0	0	1	1	1	1	0	0	1	1
4	0	0	0	0	1	0	0	1	0	1	1
5	0	0	0	0	0	1	0	1	0	1	1
6	1	0	0	0	0	0	1	1	0	1	1
7	1	1	0	0	0	1	1	1	0	1	1
8	1	1	1	0	0	0	0	0	1	1	1
9	1	1	1	1	0	1	0	0	1	1	1
.	1	0	1	0	1	0	1	1	1	0	1
,	1	0	0	1	1	0	0	1	1	0	1
?	0	1	1	0	0	1	1	1	1	1	1
/	1	0	0	1	0	1	1	1	1	0	1
-	1	0	0	0	1	1	0	1	1	0	1

Operation. The Morse-A-Letter is very easy to operate. The only adjustment that you must make is the setting of the SPEED control (R47), and only a rough setting is required. Remember that the Morse-A-Letter input is quite sensitive, so you should set the receiver's audio gain a little lower than usual. If this is done, the primary source of audio output will be the project's internal speaker, and you will quickly learn how to tune the signal in to the center of the filter passband.

Once the signal is properly tuned in, the CODE LED will blink in step with the Morse. Adjust the SPEED control so that the DAH LED glows only when dahs are sent, not when dits are. The MAN-2 display will now read out the incoming characters. Note that "illegal" Morse characters will be displayed as @. For code practice sessions, place S1 in the osc position and adjust the SPEED control for the approximate sending speed. You may wish to calibrate the SPEED control. If so, the following formula will help you determine the required calibration points: Speed (wpm) = 0.15 f. That is, the code speed in words per minute equals fifteen hundredths of the clock frequency, which is determined by the setting of SPEED control R47.

Some users might feel that the center frequency of the passband (and thus the pitch of the practice oscillator) is too high. Or it may not coincide with the center frequency of the crystal filter in a given receiver. If a change of the center frequency is contemplated, the values of R4-6 and R13-15 should be modified. Here are alternate values for two frequencies:

Resistors	800 Hz	1000 Hz
R4, R5, R13, R14	3300 ohms	2700 ohms
R6, R15	270 ohms	220 ohms

As mentioned earlier, the passband of the filter is about 100-Hz wide. A narrow filter is very desirable when used with a stable receiver that's equipped with a smooth, slow-moving tuning dial assembly. But if the receiver has a tendency to drift or the tuning dial is compressed or has some play in it, a narrow filter should not be used. Instead, the use of wide-tolerance, randomly selected, or even deliberately mismatched components for C2, C4, C5, C7, R4-6 and R13-15 is recommended to broaden the filter's passband.

As a final note, you are cautioned not to relay to a third party any information garnered from press transmissions or the like. Except for ham or broadcast transmissions, it's illegal to do so. ◇