

**Paras Khara,**  
Marketing manager,  
Sitara™ processors

**Adnan Nishat,**  
Senior product manager,  
Embedded connectivity solutions  
Texas Instruments

---

# Complete solutions for next-generation wireless connected audio

---

## Overview

More consumers are streaming music than ever before – from their smartphones, laptops, tablet computers and other devices to a variety of wirelessly connected audio devices, like portable speakers, connectivity modules, soundbars or audio/video receivers (AVRs). Plus, there's a new openness to streaming technology as designers of the connected audio devices are able to tap into the streaming capabilities of practically any streaming client device from any manufacturer. Consumers are tuning in to new capabilities, like the ability to easily stream music from a phone or tablet while still browsing the Internet. No longer does one exclude the other.

Suppliers of connected audio devices who want to take advantage of this rapidly advancing and expanding marketplace are turning to Texas Instruments (TI) to find what they need:

- Scalable processing solutions that run the gamut of connected device types, from the simplest portable speakers to high-end AVRs.

(continued)

- Robust, feature-rich and high-performance connectivity technology for Wi-Fi® and Bluetooth®.
- Versatile interoperability for connecting to any streaming client.
- Reference designs, development tools and dependable support that accelerate time-to-market.

## Capitalizing on the possibilities

Convenience and ease of use have ignited consumer interest in connected audio devices. Designers are capitalizing on this demand by incorporating new features and capabilities that meet the requirements of users who grow more discerning every day. The ubiquity of Wi-Fi access points and Bluetooth-enabled phones and tablets have seeded the opportunity for the wireless connected audio marketplace. Today, a new generation of more powerful, more capable and exceedingly robust processing and connectivity technologies are spurring another wave of growth.

## Powerful and scalable processor options

To a large extent, the previous generation of connected audio devices has run out of steam. Based largely on ARM9™ cores, processing limitations often hinder the capabilities of legacy connected audio systems. New ARM® Cortex®-A8- and Cortex-A9-based processors like TI's Sitara™ AM335x processor give designers far more powerful solutions, which, additionally, can be closely coupled with a digital signal processor (DSP) when high-end audio processing and top-notch sound quality is required.

As shown in Figure 1 on the following page, TI's Sitara AM335x processor is based on an ARM Cortex-A8 core that's scalable from 300 MHz to 1 GHz. To enable fast development of connected audio devices, the AM335x processor's high-performance capabilities are supported by a full complement of audio-oriented peripherals, including integrated streaming

audio protocol processing for AirPlay, traditional Wi-Fi's DLNA for Windows® and Android™ devices, support for iPod/Android docking devices and others.

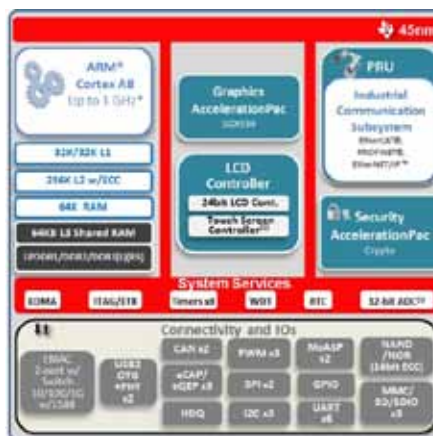

**Figure 1: Block diagram of TI's AM335x processor**

To scale upward toward high-end connected audio devices like AVRs and soundbars capable of Dolby 5.1 Surround Sound and other processing-intensive audio algorithms, the Sitara AM335x processor can be readily coupled with TI's Aureus™ high-performance audio DSPs. Together, a Sitara AM335x processor and Aureus DSP deliver unmatched processing capabilities for those demanding sophisticated connected audio applications.

### **Robust, feature-rich and high performance connectivity technology**

In addition to powerful processing, another key requirement of connected audio systems or standalone devices is a robust, feature-rich and high-performance wireless connectivity solution, such as TI's WiLink™ 8 family, the eighth-generation Wi-Fi and Bluetooth combo offering from TI. The WiLink 8 product offering consists of FCC/IC, ETSI/CE and TELEC-certified modules that minimize the required RF expertise and save customers as much as \$50,000 of test cost and test time. It also includes fully validated, mature and stable Wi-Fi driver that is tested extensively for interoperability with numerous commercially available Wi-Fi access points. It also includes a Bluetooth SIG-certified stack that supports many profiles and is tested for interoperability with hundreds of commercially available phones, accessories and other Bluetooth-enabled devices. The vast interoperability and maturity of the WiLink 8 combo solution ensures that wireless speakers and other connected audio devices will be able to receive an audio stream from practically any streaming device.

The WiLink 8 solution's robust Wi-Fi/Bluetooth coexistence capabilities allow products to combine the best of both Wi-Fi and Bluetooth. For example, Bluetooth low energy might be deployed as the interface for remote control while Wi-Fi functions as the channel for streaming audio.

Antenna diversity and 2.4 GHz and 5 GHz dual-band wireless connectivity extend the wireless communications range of the WiLink 8 module and allow it to maintain connectivity even in the most congested RF

environments. Wi-Fi's Maximum Ratio Combining (MRC) functionality gives the WiLink 8 solution the versatility and robust connectivity of two antennas when needed. In addition, by supporting 802.11a, it is able to avoid the congested 2.4-GHz spectrum by connecting over the 5-GHz band.

Advanced Wi-Fi capabilities like Wi-Fi Direct with its multi-channel/multi-role functionality give designers the opportunity to tremendously enhance the user experience for their new generation of connected audio devices. For example, a smartphone might be linked to a connected audio device like a wireless speaker via Wi-Fi Direct while the speaker with the WiLink 8 solution maintains connectivity to the Internet. The result is a greatly enhanced user experience. The smartphone streams music to the speaker, and the user is still able to browse the Internet or pull the music the user is streaming from the cloud, all without connecting to the home access point or cellular network.

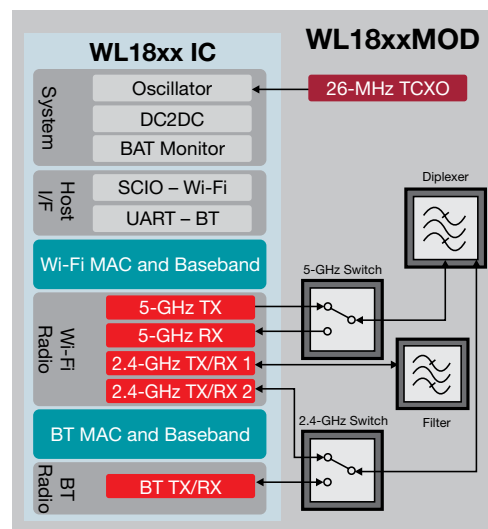

Figure 2: Block diagram of WL18xx (Dual-Band) module

### An integrated solution

Bringing together all of the pieces in a connected audio system design is simplified by the compatibilities integrated into various TI technologies. For example, the interface between the Sitara AM335x processor and WiLink 8 is fully defined and validated. In addition, TI's power management integrated circuits, such as the TPS650250, shorten a new product's time to market by enabling fast and easy development of a power subsystem for the ARM core. Sophisticated power management processes are essential for maintaining high throughput and extended operations in low-power applications such as portable battery-operated devices.

For audio out, low-power codecs like the TLV320AIC3206 with a DirectPath™ headphone amplifier feature extensive register-based control of power, input/output channel configuration, gains, effects, pin-multiplexing and clocks, allowing the device to be precisely targeted to the application.

As shown in Figure 3 on the following page, many of the underlying software modules needed to support such a system have already been integrated by TI. These include all of the software stacks for complete Wi-Fi and Bluetooth connectivity, Linux™ support, Android and various real-time operating systems, a considerable

amount of firmware as well as low-level drivers for an AIC codec, USB and the WiLink 8 module and Sitara AM335x processor. The AM335x processor is also supported by GStreamer, an open-source media framework that supports a variety of audio codecs like FLAC, ACC, MP3 and others. Compatibility with Internet radio services like Spotify, Pandora, Rhapsody and others is also built into the system's software framework.

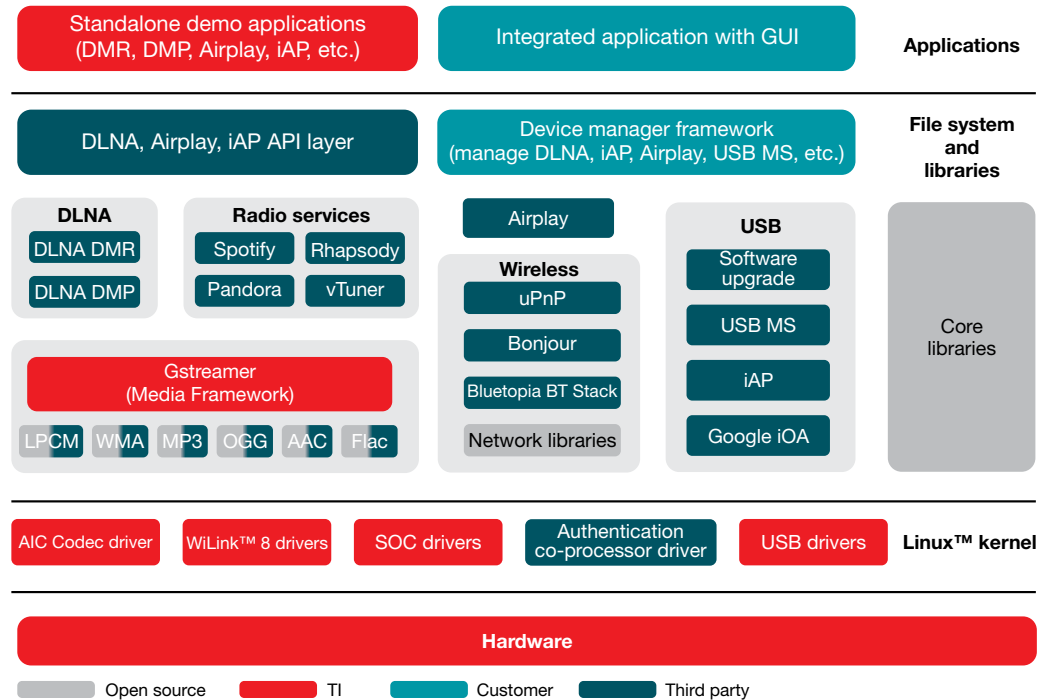

Figure 3: Audio streaming system software

**Conclusions**

Many consumers have discovered the convenience and versatility that wireless connected audio devices and systems have offered. Now, powerful advancements in processing and connectivity technologies, as well as a higher degree of interoperability among connected audio devices and streaming clients is ushering in innovative and exciting possibilities for super-charging the user experience. New, easier and faster connectivity options, improved sound quality, multitasking capabilities and other enhancements will attract the next wave of consumers to the connected audio marketplace and ensure its continued growth.

**For more information** For more information on TI's Sitara AM335x processors, please visit [www.ti.com/pro-arm-audiowp-lp](http://www.ti.com/pro-arm-audiowp-lp)  
For more information on TI's WiLink 8 family, please visit [www.ti.com/pro-arm-audiowp-lp2](http://www.ti.com/pro-arm-audiowp-lp2)  
For more information on TI's Aureus high-performance audio DSPs, please contact your local TI sales representative.  
For more information on TI's audio codecs, please visit [www.ti.com/pro-arm-audiowp-lp3](http://www.ti.com/pro-arm-audiowp-lp3)

Important Notice: The products and services of Texas Instruments Incorporated and its subsidiaries described herein are sold subject to TI's standard terms and conditions of sale. Customers are advised to obtain the most current and complete information about TI products and services before placing orders. TI assumes no liability for applications assistance, customer's applications or product designs, software performance, or infringement of patents. The publication of information regarding any other company's products or services does not constitute TI's approval, warranty or endorsement thereof.

Aureus, DirectPath, Sitara and WiLink are trademarks of Texas Instruments Incorporated. All other trademarks are the property of their respective owners.

## IMPORTANT NOTICE

Texas Instruments Incorporated and its subsidiaries (TI) reserve the right to make corrections, enhancements, improvements and other changes to its semiconductor products and services per JESD46, latest issue, and to discontinue any product or service per JESD48, latest issue. Buyers should obtain the latest relevant information before placing orders and should verify that such information is current and complete. All semiconductor products (also referred to herein as "components") are sold subject to TI's terms and conditions of sale supplied at the time of order acknowledgment.

TI warrants performance of its components to the specifications applicable at the time of sale, in accordance with the warranty in TI's terms and conditions of sale of semiconductor products. Testing and other quality control techniques are used to the extent TI deems necessary to support this warranty. Except where mandated by applicable law, testing of all parameters of each component is not necessarily performed.

TI assumes no liability for applications assistance or the design of Buyers' products. Buyers are responsible for their products and applications using TI components. To minimize the risks associated with Buyers' products and applications, Buyers should provide adequate design and operating safeguards.

TI does not warrant or represent that any license, either express or implied, is granted under any patent right, copyright, mask work right, or other intellectual property right relating to any combination, machine, or process in which TI components or services are used. Information published by TI regarding third-party products or services does not constitute a license to use such products or services or a warranty or endorsement thereof. Use of such information may require a license from a third party under the patents or other intellectual property of the third party, or a license from TI under the patents or other intellectual property of TI.

Reproduction of significant portions of TI information in TI data books or data sheets is permissible only if reproduction is without alteration and is accompanied by all associated warranties, conditions, limitations, and notices. TI is not responsible or liable for such altered documentation. Information of third parties may be subject to additional restrictions.

Resale of TI components or services with statements different from or beyond the parameters stated by TI for that component or service voids all express and any implied warranties for the associated TI component or service and is an unfair and deceptive business practice. TI is not responsible or liable for any such statements.

Buyer acknowledges and agrees that it is solely responsible for compliance with all legal, regulatory and safety-related requirements concerning its products, and any use of TI components in its applications, notwithstanding any applications-related information or support that may be provided by TI. Buyer represents and agrees that it has all the necessary expertise to create and implement safeguards which anticipate dangerous consequences of failures, monitor failures and their consequences, lessen the likelihood of failures that might cause harm and take appropriate remedial actions. Buyer will fully indemnify TI and its representatives against any damages arising out of the use of any TI components in safety-critical applications.

In some cases, TI components may be promoted specifically to facilitate safety-related applications. With such components, TI's goal is to help enable customers to design and create their own end-product solutions that meet applicable functional safety standards and requirements. Nonetheless, such components are subject to these terms.

No TI components are authorized for use in FDA Class III (or similar life-critical medical equipment) unless authorized officers of the parties have executed a special agreement specifically governing such use.

Only those TI components which TI has specifically designated as military grade or "enhanced plastic" are designed and intended for use in military/aerospace applications or environments. Buyer acknowledges and agrees that any military or aerospace use of TI components which have **not** been so designated is solely at the Buyer's risk, and that Buyer is solely responsible for compliance with all legal and regulatory requirements in connection with such use.

TI has specifically designated certain components as meeting ISO/TS16949 requirements, mainly for automotive use. In any case of use of non-designated products, TI will not be responsible for any failure to meet ISO/TS16949.

### Products

Audio	<a href="http://www.ti.com/audio">www.ti.com/audio</a>
Amplifiers	<a href="http://amplifier.ti.com">amplifier.ti.com</a>
Data Converters	<a href="http://dataconverter.ti.com">dataconverter.ti.com</a>
DLP® Products	<a href="http://www.dlp.com">www.dlp.com</a>
DSP	<a href="http://dsp.ti.com">dsp.ti.com</a>
Clocks and Timers	<a href="http://www.ti.com/clocks">www.ti.com/clocks</a>
Interface	<a href="http://interface.ti.com">interface.ti.com</a>
Logic	<a href="http://logic.ti.com">logic.ti.com</a>
Power Mgmt	<a href="http://power.ti.com">power.ti.com</a>
Microcontrollers	<a href="http://microcontroller.ti.com">microcontroller.ti.com</a>
RFID	<a href="http://www.ti-rfid.com">www.ti-rfid.com</a>
OMAP Applications Processors	<a href="http://www.ti.com/omap">www.ti.com/omap</a>
Wireless Connectivity	<a href="http://www.ti.com/wirelessconnectivity">www.ti.com/wirelessconnectivity</a>

### Applications

Automotive and Transportation	<a href="http://www.ti.com/automotive">www.ti.com/automotive</a>
Communications and Telecom	<a href="http://www.ti.com/communications">www.ti.com/communications</a>
Computers and Peripherals	<a href="http://www.ti.com/computers">www.ti.com/computers</a>
Consumer Electronics	<a href="http://www.ti.com/consumer-apps">www.ti.com/consumer-apps</a>
Energy and Lighting	<a href="http://www.ti.com/energy">www.ti.com/energy</a>
Industrial	<a href="http://www.ti.com/industrial">www.ti.com/industrial</a>
Medical	<a href="http://www.ti.com/medical">www.ti.com/medical</a>
Security	<a href="http://www.ti.com/security">www.ti.com/security</a>
Space, Avionics and Defense	<a href="http://www.ti.com/space-avionics-defense">www.ti.com/space-avionics-defense</a>
Video and Imaging	<a href="http://www.ti.com/video">www.ti.com/video</a>

### TI E2E Community

[e2e.ti.com](http://e2e.ti.com)