

If your home or office has more than one telephone extension, you've probably had the unpleasant experience of picking up the phone only to find it already in use. You may get an angry response from the person on the other end. If a modem is in use, you'll be greeted by the obnoxious squall of two computers exchanging bits. Such an interruption usually means a lost connection, or the corruption of a file being transferred.

A solution to that problem is the Phone Sentry—an inexpensive, simple, reliable indicator that warns you when a phone extension is in use. The Phone Sentry is easy to build and install in one evening, and presents no load to the phone line. It's small, inconspicuous, and costs only \$5 a copy.

How it works

To understand how the Phone Sentry works, you need to understand how the telephone system works—or, at least, how the local subscriber loop works, since that's the part that enters into your house.

The telephone line is held at about 45 volts DC by the local switching office when it's hung up. When a telephone is taken off its hook, a 1K load brings the line down to 6 volts DC. The line stays at 6 volts DC until you hang up, then it returns to 45 volts DC and is disconnected.

The Phone Sentry operates by monitoring the telephone line voltage and switching on a flashing LED whenever the voltage drops below 20 volts. The Phone Sentry can be placed anywhere on a phone line, not just on an extension in use.

Circuit operation

The Phone Sentry circuit is deceptively simple, yet elegant in design. At the heart of the circuit is IC1, a CMOS CD4093B quad NAND gate Schmitt trigger.

Ordinary CMOS gates switch midway between the voltage of the positive and negative supplies. For a circuit powered from 5 volts, this point (called 0.5 V+) is 2.5 volts. When the input voltage rises past or falls below that point, the output will switch. Normally, that's a desirable characteristic, and is one of

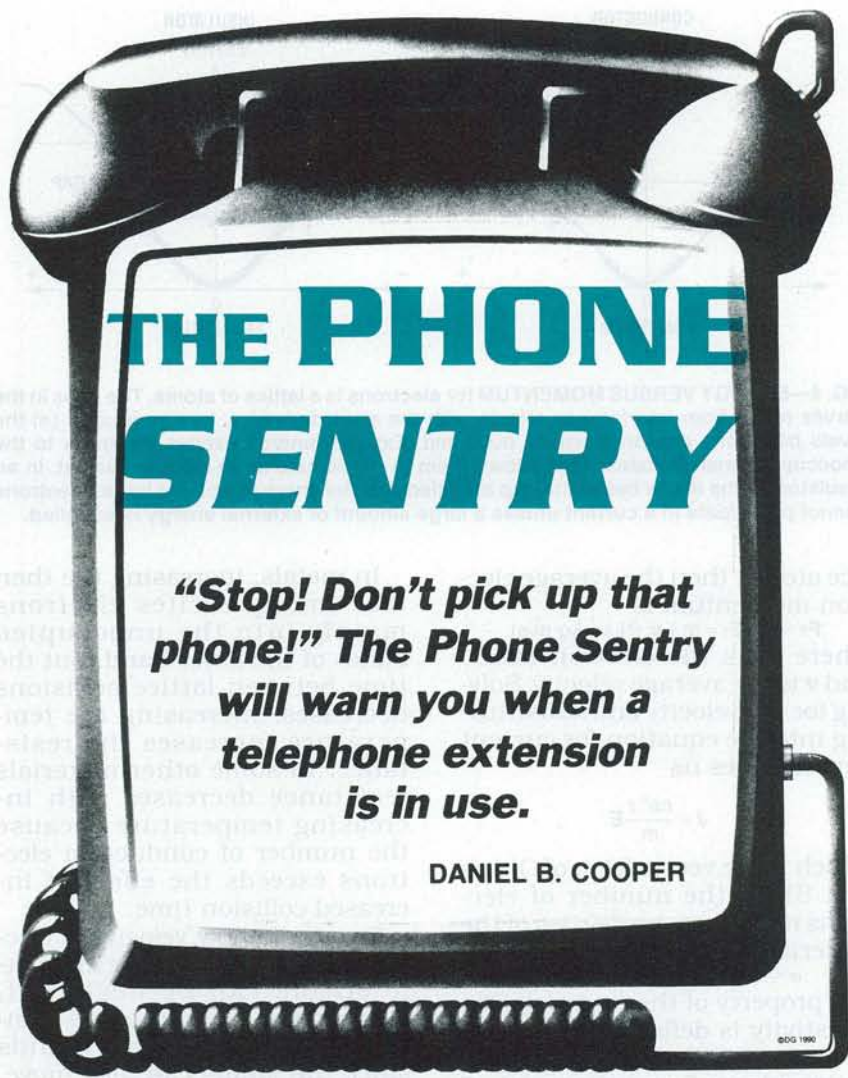

CMOS's good points. However, when a CMOS input is presented with a slowly changing or noisy input, the symmetrical switching characteristic can cause the circuit to jitter or oscillate as the input nears the 0.5 +V point.

The Schmitt trigger input handles noisy environments by separating the rising and falling voltage-switching points. A Schmitt trigger input will react to a rising input voltage only when it passes a threshold that is higher than 50% of the supply voltage, usually about 70%, or 0.7 +V. A falling input voltage will cause a change only when it falls below a much lower threshold of about 30% of the supply, or 0.3 +V. An input voltage between those two thresholds will have no effect until it rises above 0.7 +V, or falls below 0.3 +V.

The region between the 70% and 30% switching levels is

called the hysteresis gap, or dead band. Hysteresis permits a Schmitt trigger input to respond very cleanly to noisy or irregular input signals. It also permits some fancy tricks, such as one-gate oscillators. It is the latter capability for which a Schmitt NAND gate is used in the Phone Sentry.

Figure 1 shows a block diagram of the Phone Sentry. The four gates of the CD4093B are used as three separate elements. One Schmitt-trigger NAND gate acts as an input comparator to monitor a phone line. It in turn gates another NAND gate used as an oscillator, which drives a high-current buffer for LED1.

The schematic of the Phone Sentry is shown in Fig. 2, with its circuit waveforms at critical locations shown in Fig. 3. Bridge rectifier D1–D4 eliminates any phone-line polarity problems. It also removes the 80-volt peak-to-

peak ring signal, which could damage the Phone Sentry or make LED1 flicker.

The output of the bridge rectifier is divided down by R1-R2, with 27% of the input voltage reaching IC1-a. 27% represents the voltage divider of the $[(R2/(R1 + R2))]$ ratio, which equals $[1 \text{ megohm}/(1 \text{ megohm} + 2.7 \text{ megohm})] = 0.27$

The bridge always presents two of the four diodes as a phone-line load, D1-D4 or D2-D3, dropping the line voltage down by 0.7 volts DC each, or 1.4 volts total. Since the input impedances of pins 12 and 13 of IC1-a are almost infinite, they draw no current. What appears across R1 and R2 in series should be about $45 \text{ V} - 1.4 \text{ V} = 43.6 \text{ V}$.

The voltage at pins 12 and 13 with the phone hung up is therefore $43.6 \text{ V} \times 0.27 = 11.78 \text{ V}$,

which is 2.78 volts above the 9-volt DC supply. The IC, however, is protected from overcurrent burnout by R1 and internal diodes. When an extension is in use, the 6 volts on the line goes down to $(6 \text{ V} - 1.4 \text{ V}) \times 0.27 = 1.24 \text{ V}$.

Capacitor C1 filters out small spikes that can be generated during the ringing cycle, protecting the IC and eliminating any residual tendency of the LED to flicker.

Because the comparator is a Schmitt NAND gate, its output (pin 11) will be low whenever the input voltage is above about 6.3 volts (70% of 9 volts), and high whenever the input drops below about 2.7 volts (30% of 9 volts). Those switching values fit perfectly with the 11.78 and 1.24 volts generated from the phone line by the rectifier and divider. The output will be low when all phones are on-hook, and high when any phone is picked up, or a modem is connected to the line.

The LED could be driven directly by IC1-a, but B1 would be drained in about 10 hours because LED1 draws 10 milliamps when lit. To extend battery life to at least 100 hours, IC1-b, the low 5% duty-cycle oscillator, is gated by IC1-a, driving LED1 and giving a bright flash with much lower current drain.

The output of the comparator is used to gate an oscillator on and off. That oscillator consists

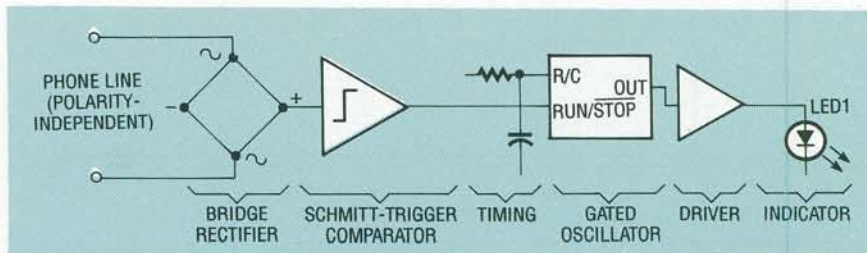

FIG. 1—BLOCK DIAGRAM OF THE PHONE SENTRY. The rectified phone-line voltage drives a comparator, whose output gates a low duty-cycle oscillator. The oscillator drives a CMOS buffer/driver. The period and duty cycle of the oscillator are controlled by timing components R3, R4, and C2.

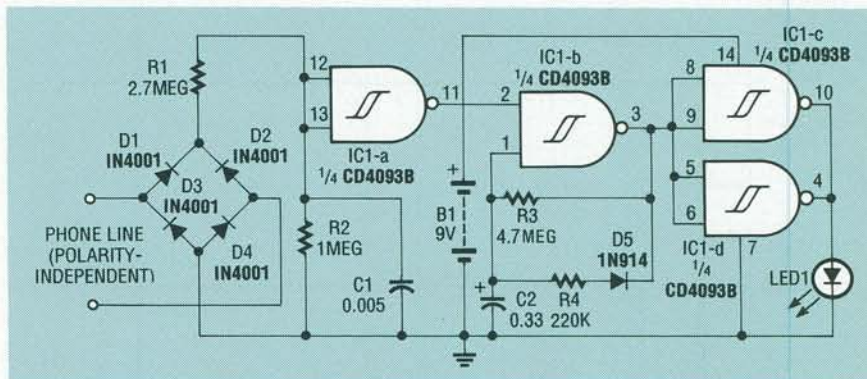
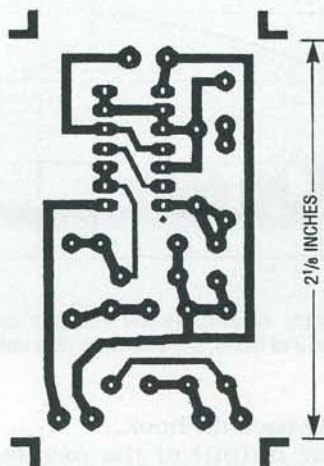

FIG. 2—SCHEMATIC OF THE PHONE SENTRY, using a CD4093B quad NAND-gate Schmitt trigger. The green (tip) and red (ring) phone-line wires are polarity-independent due to D1-D4. Input comparator IC1-a gates IC1-b, a single-gate oscillator, which drives IC1-c and -d, used in tandem as a high-current buffer/driver.



THE PC-BOARD FOIL PATTERN FOR THE Phone Sentry.

of a second Schmitt NAND gate (IC1-b), R3, R4, C2, and D5. When pin 2 of IC1 is held low by the comparator, the output of the gate is held high. That output is used to charge timing capacitor, C2, through timing resistor R3. The junction of components R3 and C2 is connected to pin 1. With the output held high, the charge on C2 will rise to the level of the supply voltage.

When a phone is picked up and the loop voltage drops, the comparator's output goes high and the oscillator is enabled. Since

PARTS LIST	
All resistors are 1/4-watt, 5%.	
R1	2.7 megohms
R2	1 megohm
R3	4.7 megohms
R4	220,000 ohms
Capacitors	
C1	0.005 μ F, 100 volts, disc or monolithic
C2	0.33 μ F, 16 volts, tantalum or electrolytic
Semiconductors	
D1-D4	1N4001 diode
D5	1N4148 diode
IC1	CD4093B quad Schmitt trigger NAND-gate
LED1	light-emitting diode, any size or color
Miscellaneous: 9-volt alkaline battery with clip, PC board (see foil pattern), 22-AWG wire, plastic case (optional), LED mounting clip (optional), modular plug-to-bare wire phone cable (optional), two-way phone jack duplexer, 14-pin DIP IC socket.	

both inputs are now high, the output switches low. The charge of C2 is drained, partly through R3, but more quickly through R4 and D5. When the voltage at pin 1 drops below the Schmitt input's lower threshold, the output of the gate switches high, and the capacitor begins charging again through R3. When the capacitor voltage reaches the Schmitt's upper threshold, the output switch-

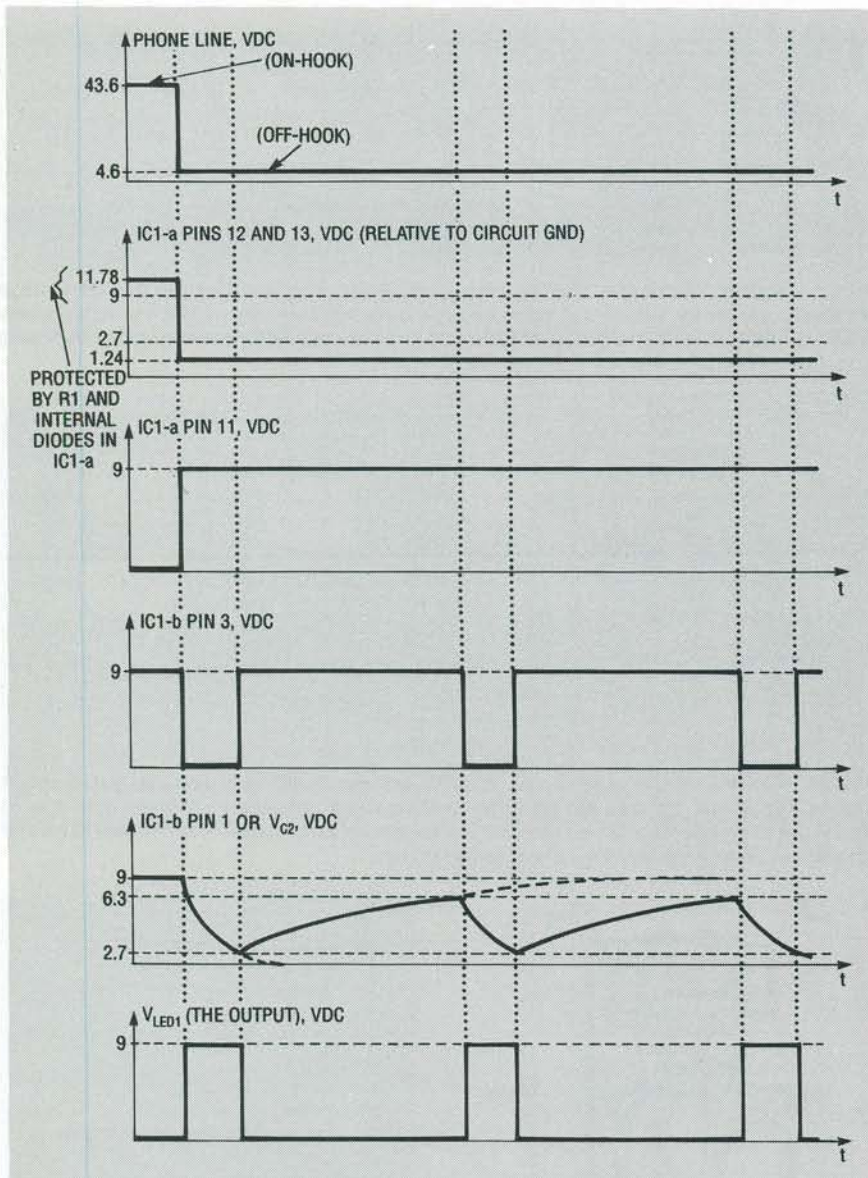

FIG. 3—CIRCUIT WAVEFORMS OF THE Phone Sentry. Shown are the voltages on the phone line, pins 12 and 13 of IC1-a, pin 11 of IC1-a, pin 3 of IC1-b, pin 1 of IC1-b (the voltage across C2), and across LED1.

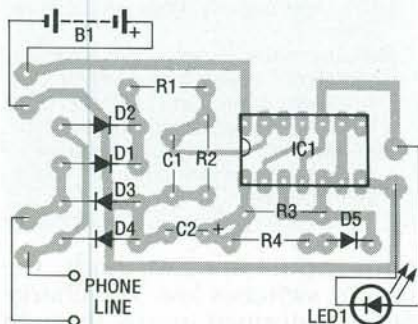

FIG. 4—THE PARTS PLACEMENT DIAGRAM of the Phone Sentry. You can mount LED1 in several ways, depending on how you mount the PC board.

charge to the lower threshold the first time. Therefore, the first flash of the LED is longer and brighter than those that follow. That's a nice touch, because all of the Phone Sentries in the house will give an initial bright flash when a phone is first picked up to answer a call.

Construction and installation

The Phone Sentry can be assembled on either a PC board, shown here, or on perforated construction board of similar size. The PC board is about the size of B1, so housing the unit is simple, and its construction is straightforward. Figure 4 shows the parts placement diagram; use a socket for IC1, and install it using proper anti-static handling techniques.

The Phone Sentry is small, with several installation options. Once you decide how to mount it, you can select how to wire both the phone line and LED1. If you put the Phone Sentry inside an extension or a wall-mount jack, then solder a foot of 22-AWG wire to each input terminal.

If you use a small case for plugging into a wall socket, solder the green (tip) and red (ring) wires of a modular plug-to-bare-wire phone cord, and clip the yellow and black wires. You may want to solder LED1 directly to the PC board, or mount it in a visible location with two 6-inch pieces of stiff wire.

You can mount both the PC board and B1 in a standard desk phone. Open the phone and secure both the PC board and battery clip to the baseplate with double-sided foam tape. Drill a small hole in the dialing button escutcheon, and use silicone sealant or an LED clip to mount LED1. Connect the two input wires to the tip and ring wires, insert B1, replace the cover, and plug the phone back in.

If there's no space for the Phone Sentry and B1, use a small plastic box on the side of the phone for the PC board, B1, and LED1, and pass the tip and ring wires through a hole in the box and phone case to the connecting points inside the phone. For a wall phone, mount the same case near the wall jack and run the wiring into the wall jack, so it's independent of the phone. R-E

going back on-hook.

The output of the oscillator (pin 3) is inverted and used to drive the indicator LED. When the oscillator's output is high, the output of the driver (pins 10 and 4) is low, and the LED is off. When the oscillator output is low, the driver output is high, and the LED is on. Since the capacitor discharge time (oscillator output low) is much shorter than the charge time (oscillator output high), the LED is on much less time than it is off, resulting in a very low duty cycle, and low battery drain.

Because the capacitor starts each cycle charged much higher than the Schmitt input's upper threshold, it takes longer to dis-

es low again and the process repeats until the gating input is again brought low by the phone