

**It's quick and easy to add an intercom feature to your existing home telephones.**

**FRANK POLIMENE**

# USE YOUR TELEPHONES AS A HOME INTERCOM SYSTEM

INTERCOMS HAVE BEEN AROUND FOR many years, providing a valuable tool in communications for home and industry. Unfortunately, these systems either require added hardware or hours of labor installing wires. Responding to demand, many manufacturers have incorporated the intercom as an added feature in their telephones. However, replacing your existing equipment is an expense that usually outweighs the justification.

The Phone-Com project we will describe may be used concurrently with any touch-tone phone system, and it provides features that make it practical, easy to use, and inexpensive. Because it connects to your existing

telephone equipment, there are no unsightly boxes to clutter up your desk.

## How it works

To engage the intercom at any time, all you have to do is pick up any phone and press the "#" key. That causes one or more *alert modules* to sound an alarm, signalling other people in the home to pick up a phone. If you answer a call that comes in for someone else, pressing the "#" key will place the call on hold, and the alarm will sound on the alert modules signalling someone else in the home to pick up the phone. That someone else may then release the call on hold by pressing the "#" key or talk to you in pri-

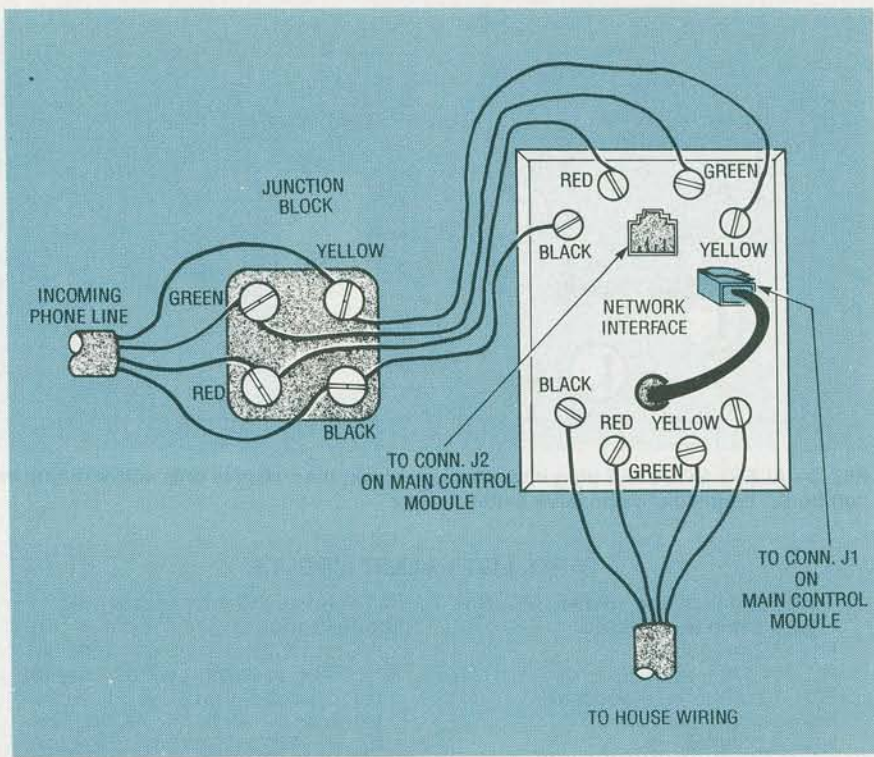

**FIG. 1—THE PHONE-COM TAKES ADVANTAGE** of a device called a "network interface," installed in most newer homes; it is simply a connector box that separates the outside phone line from your internal wiring.

vate before answering the call. Since the system is voice operated (VOX), the intercom will disengage and return to normal operation after approximately 30 seconds if no conversation is heard.

The Phone-Com takes advantage of a device called a "network interface," installed in most new homes over the past 10 years. Despite the complicated name, it is simply a connector box that separates the outside phone line from your internal wiring (see Fig. 1). Since a network interface is used by the phone company to determine whether problems are internal or external, a substantial premium service charge may be imposed if you don't have one. Therefore, it is highly recommended that one be installed, even if not for this project.

### Theory of operation

Take a look at the schematic in Fig. 2. In the stand-by mode, relay RY1 is not energized and the only connection to the phone line is the coupling-capacitor C1. The

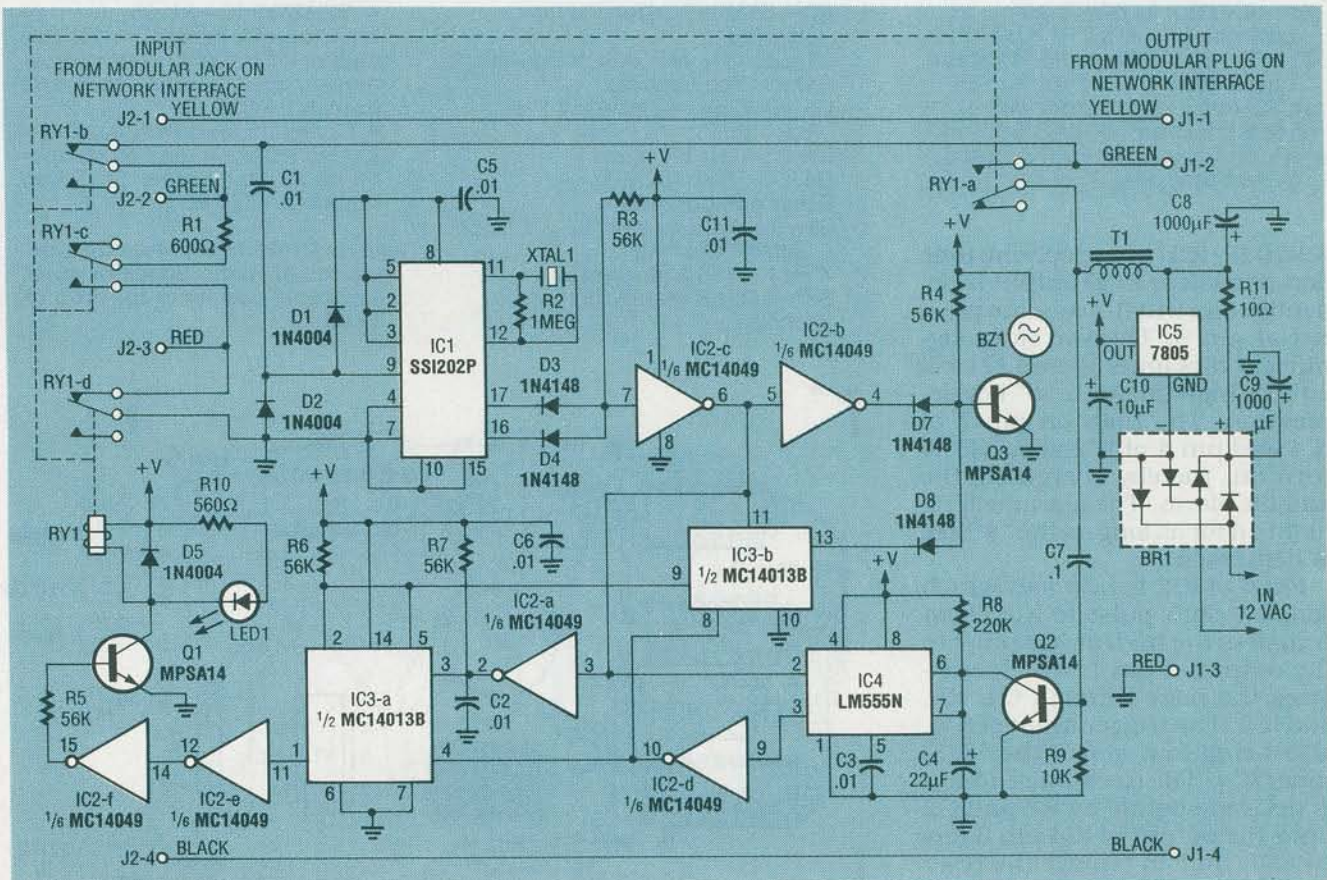

**FIG. 2—CONTROLLER SCHEMATIC.** The SSI202P is a telephone tone decoder whose BCD output is dependent on which tones are present at pin 9.

## PARTS LIST—CONTROLLER

All resistors are ¼-watt, 5%, unless otherwise noted.

- R1—600 ohms, ½-watt  
 R2—1 megohm  
 R3—R7—56,000 ohms  
 R8—220,000 ohms  
 R9—10,000 ohms  
 R10—560 ohms  
 R11—10 ohms  
**Capacitors**  
 C1—0.01 µF, 200 volts, ceramic disc  
 C2, C3, C5, C6, C11—0.01 µF, 50 volts, ceramic disc  
 C4—22 µF, 16 volts, tantalum  
 C7—0.1 µF, 50 volts, ceramic disc  
 C8, C9—1000 µF, 16 volts, electrolytic  
 C10—10 µF, 35 volts, electrolytic  
**Semiconductors**  
 IC1—SSI202P telephone tone decoder  
 IC2—MC14049 hex inverting buffer  
 IC3—MC14013B dual D-type flip-flop  
 IC4—LM555N timer  
 IC5—7805 5-volt regulator  
 Q1—Q3—MPSA14 or equivalent Darlington transistor  
 D3, D4, D7, D8—1N4148 diode  
 D1, D2, D5—1N4004 diode  
 LED1—red light-emitting diode  
 BR1—3N246 full-wave bridge rectifier  
**Other components**  
 BZ1—100-dB Mallory Sonalert module  
 XTAL1—3.58-MHz crystal  
 RY1—DPDT mini relay, 1-amp contacts, 12-volt coil  
 T1—600/600 ohm audio isolation transformer  
 J1, J2—modular telephone jack  
**Miscellaneous:** 12-VAC 500-mA plug-in transformer, PC board, project case, etc.

SSI202P (IC1) is a telephone tone decoder whose BCD output is dependent on which tones are present at pin 9. The two most-significant bits (pins 16 and 17) will only be high during a “#” key depression. The high on pin 7 of IC4 and pin 4 of IC2 allow Q3 to turn on, thereby energizing the audible alarm. The alarm will remain on for as long as the “#” key is depressed.

Pin 6 of IC2 is now low, which sends a clock pulse to IC3. That transfers the high at IC3 pin 2 to the output at pin 1, which energizes the relay through Q1, R5, and IC2. The trigger input of IC4, also being low, starts the VOX-timer IC4. The clock pulse to IC3 is delayed slightly by R7 and C2 until the output of IC4 pin 3 has enough time to remove the reset signal at IC3 pin 4. When the “#” key is released, pin 11 of IC3 goes high and toggles the output of

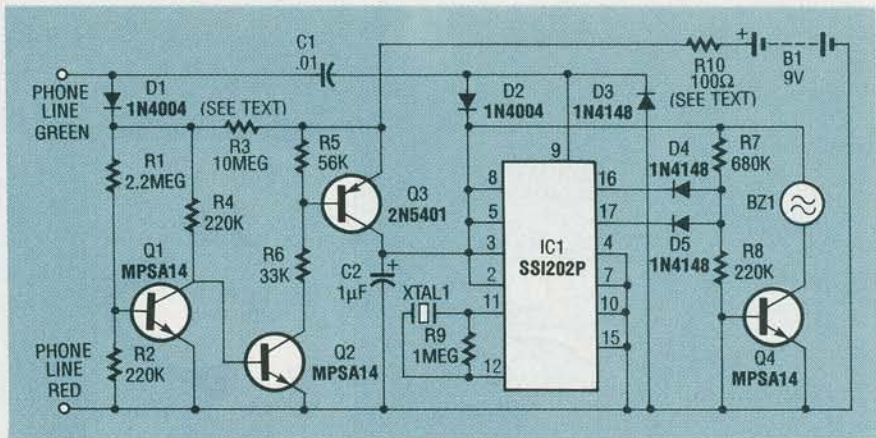

FIG. 3—ALERT MODULES plug into any phone jack; the circuit is only active during an “off hook” condition to conserve battery power.

## PARTS LIST—ALERT MODULE

All resistors are ¼-watt, 5%, unless otherwise noted.

- R1—2.2 megohms  
 R2, R4, R8—220,000 ohms  
 R3—10 megohms (see text)  
 R5—56,000 ohms  
 R6—33,000 ohms  
 R7—680,000 ohms  
 R9—1 megohm  
 R10—100 ohms (see text)  
**Capacitors**  
 C1—0.01 µF, 500 volts, ceramic disc  
 C2—1 µF, 16 volts, electrolytic  
**Semiconductors**  
 IC1—SSI202P telephone tone decoder  
 Q1, Q2, Q4—MPSA14 or equivalent Darlington transistor  
 Q3—2N5401 or equivalent PNP transistor  
 D1—D3—1N4004 diode  
 D4, D5—1N4148 diode  
**Other components**  
 B1—9-volt alkaline or 7.2-volt Ni-Cd battery (see text)  
 XTAL1—3.58 MHz crystal  
 BZ1—100-dB Mallory Sonalert module

PL1—4-wire modular phone plug  
**Miscellaneous:** 9-volt battery connector, PC board, project case, etc.

**Note:** The following items may be purchased from BCT Electronics, 8742 Belair Road, Baltimore, MD 21236 (301) 256-0344. MC/VISA, AX, and DISCOVER accepted. Add \$2.50 S&H for each total order.

- Drilled, etched, and screened controller PC board—\$7.95
- Drilled, etched, and screened alert module PC board—\$4.95
- SSI202P IC—\$11.95
- Complete controller kit (includes PC board and all components except phone jacks and housing)—\$39.95
- Complete alert module kit (includes PC board and all components except phone plug and housing)—\$24.95

Network Interfaces may be purchased at Radio Shack or most electronic suppliers for around \$5.00.

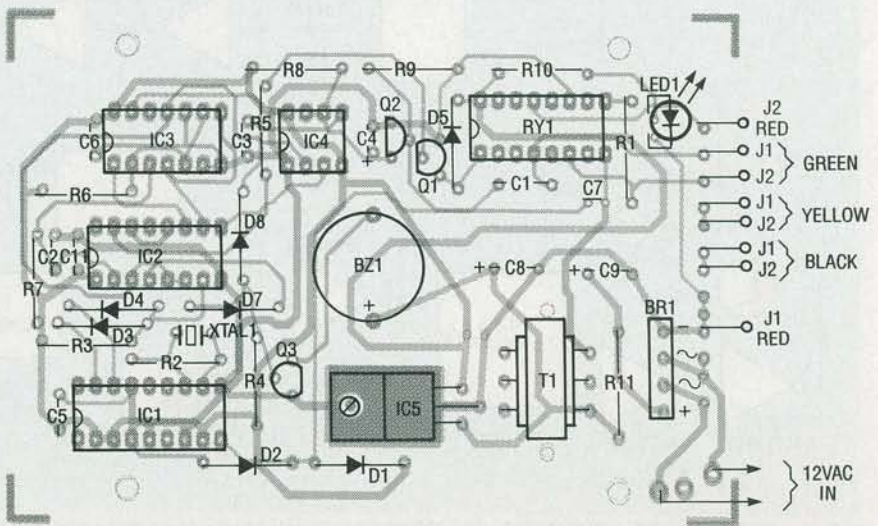

FIG. 4—PARTS-PLACEMENT DIAGRAM for the controller. It can be installed in any kind of case you can find.

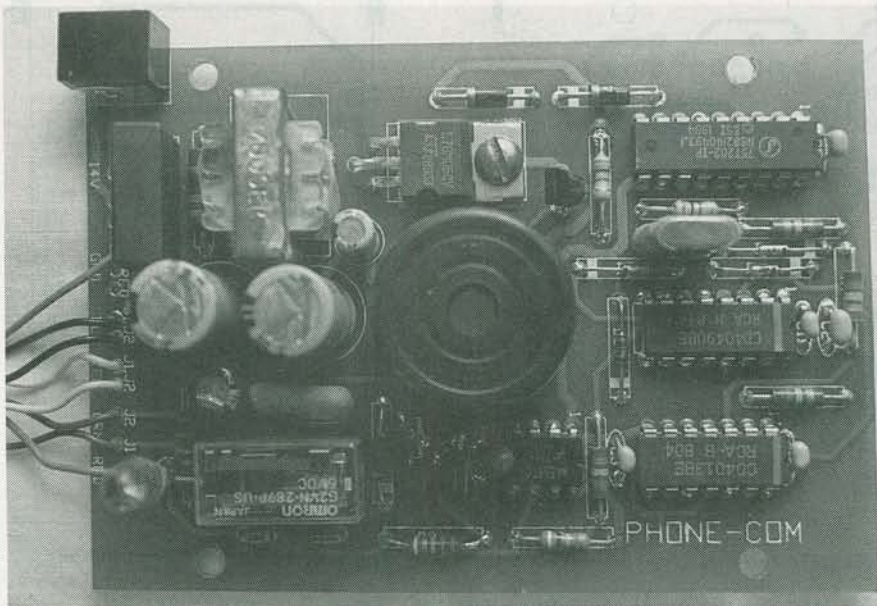

FIG. 5—THE FINISHED CONTROLLER BOARD is very neat and compact, so it doesn't take up much space.

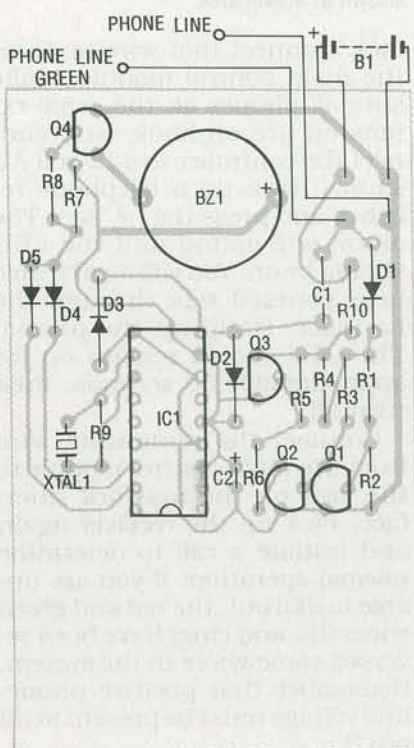

FIG. 6—PARTS-PLACEMENT DIAGRAM for the alert module. It's good to have at least one on every floor in your home, in a central location.

IC3 pin 13 to a low state, preventing the alarm to sound during the next depression of the “#” key (manual turn off).

If conversation continues, IC4 is prevented from time-out through C7 and Q2. If conversation stops for more than 30 seconds, C4 charges to the threshold voltage at IC4 pin 6 and

IC4 pin 3 returns to a low state. That places a high on the reset pin (pin 4) and the set pin (pin 8) of IC3, which turns off RY1, returning the system to the standby mode. Any calls in process are held by maintaining central-office loop current through R1 while in intercom mode.

#### Alert module

Alert modules plug into any phone jack (see Fig. 3), and can be powered by either a 7.2-volt rechargeable Ni-Cd or 9-volt al-

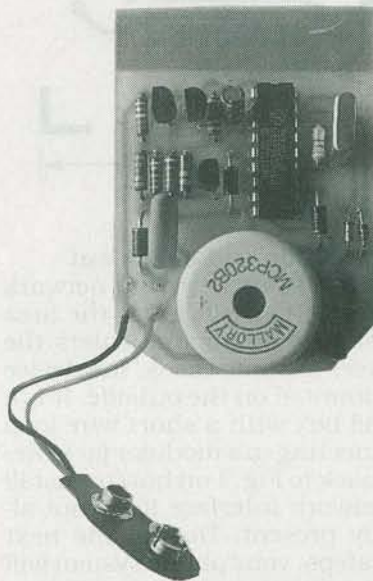

FIG. 7—A FINISHED ALERT MODULE. It can plug into any ordinary phone jack; use a T-connector if you must connect both a phone and an alert module to the same jack.

kaline battery. However, the circuit is only active during an “off hook” condition to conserve the battery. During normal operation, there is approximately 50 volts on the phone line. That allows base current to flow through R1 which turns on Q1 and holds Q2 in an off state preventing power to IC1 and the audible alarm. When the line voltage falls below 10 volts, as evident in an off-hook condition, Q2 turns on, thereby placing IC1 in the standby mode.

Telephone tones are decoded by IC1 as previously discussed. A “#” key activation will activate the alarm. Diode D1 is important in that it protects IC1 and the rest of the semiconductors from damage when the AC ringing voltage is present on the phone line. If you're using a rechargeable battery, charging current is supplied through R3 during on-hook conditions.

#### Construction

The Phone-Com controller is built on one PC board, and the alert modules are built on separate boards. Determine the number of alert modules you will need including the master control unit. The modules are loud enough to cover approximately 1000 square feet each, even when placed behind furniture. It is recommended that one module be installed in a central location on each floor of your house. Construction is straightforward, however, care should be taken when handling the static-sensitive decoder chips.

We have provided foil patterns for both boards, although the project can be built using point-to-point wiring. Double check your wiring before connecting the modules to the phone line if you don't use the boards. Figure 4 is a parts-placement diagram for the controller board. The finished board, shown in Fig. 5, can be installed in any kind of case you see fit.

The values for R3 and R10 depend on what type of battery you are using. Use 10 megohms for R3 and 82 ohms for R10 for a 9-volt alkaline battery. If a rechargeable battery is used, change the value of R3 to 82K and R10 to 10 ohms. Any audio

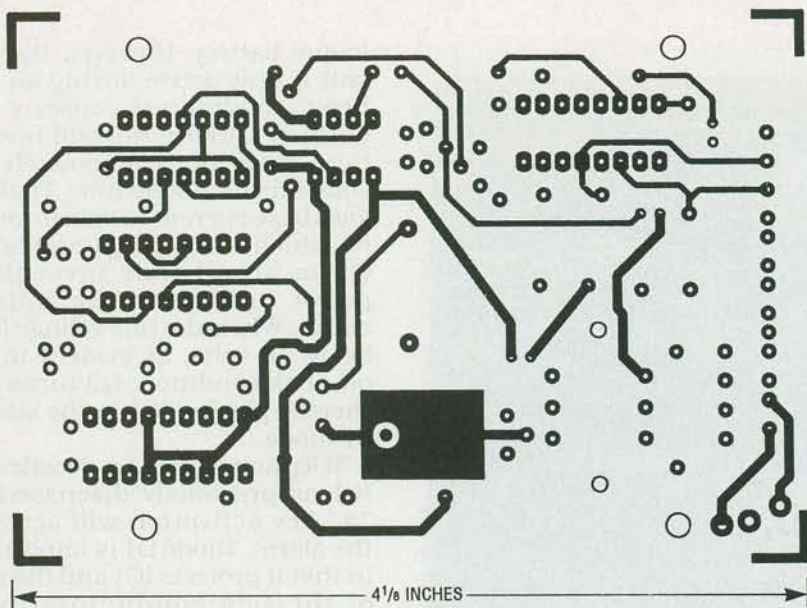

THE CONTROLLER BOARD is double-sided; here's the component side shown at actual size.

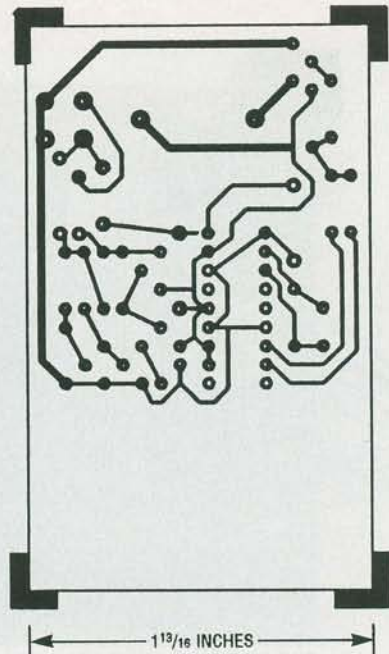

FOIL PATTERN for the alert module, also shown at actual size.

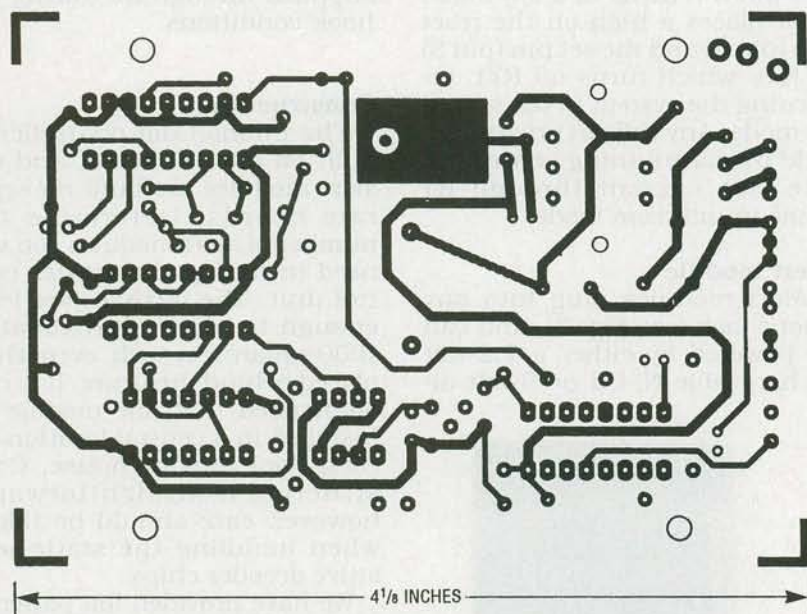

SOLDER SIDE of the controller board shown at actual size.

transformer with approximately a 500-ohm primary may be used for T1.

Figure 6 is a parts-placement diagram for the alert module, and Fig. 7 shows a finished unit. Again, the board can be installed in any case you like.

Follow the red/green color code shown in Figs. 2 and 3 when connecting the system to the phone line. A "T" adapter may be used if you need to connect additional equipment to the same jack. Velcro strips offer an easy way to secure the modules to a wall.

#### Installation and check out

Determine where your network interface is by locating the area where the phone line enters the house. In some cases, the device is mounted on the outside. It is a small box with a short wire loop connecting to a modular jack. Refer back to Fig. 1 on how to install a network interface if it's not already present. During the next few steps, your phone system will be inoperative until installation is complete.

Disconnect the short wire from the jack on the network inter-

face. Connect that wire to J1 on the main control module. Make sure all phones on the same extension are on-hook, and connect the controller to a 12-volt AC source. Pick up a telephone receiver and press the "#" key. The alarm will sound and the LED should be on. You will also be able hear yourself talk through the handset. Hang up the phone. The LED should remain on for approximately 30 seconds, then turn off.

Connect the remaining wire from the main control module to the jack on the network interface. Pick up the receiver again and initiate a call to determine normal operation. If you are unable to dial out, the red and green wires (tip and ring) have been reversed somewhere in the system. Remember that positive phone-line voltage must be present at J2 pin 2.

It may be necessary to toggle the "#" key once or twice to get everything going when the system is first installed or after a power failure. Install the alert modules and determine the correct polarity by measuring a positive voltage at the anode of D1. Reverse the wires in the module if it turns out to be necessary. If a rechargeable battery is used, you should allow it to charge for at least 24 hours before activating the system.

R-E