



LUMISCAN ACR-2000 SERVICE MANUAL

 **LUMISYS**

 LUMISYS

LUMISCAN ACR-2000
SERVICE MANUAL

P/N 0070-715, Rev 02

JANUARY, 2000

This page intentionally left blank

FOREWORD

LUMISCAN ACR-2000 SERVICE MANUAL

P/N 0070-715 Rev 02

Proprietary Notice and Disclaimer

The information herein disclosed is the property of Lumisys. Information in this document is subject to change without notice and does not represent a commitment by **Lumisys** to incorporate changes or improvements in units previously sold or shipped. No part of this document may be reproduced or transmitted in any form, electronic or mechanical, including photocopying and recording, for any purpose other than the purchaser's own use without the express written permission of **Lumisys**.

Copyright 1999. All rights reserved.

Trademarks

Lumisys, LUMISCAN 20, LUMISCAN 50, LUMISCAN 75, LUMISCAN 85, LUMISCAN 85LF and **ACR-2000** are the trademarks of **Lumisys**. All other trademarks are the property of their respective owners, and are hereby acknowledged.

Warranty

One (1) year parts warranty.

For more information contact:

Lumisys
225 Humboldt Ct.
Sunnyvale, CA 94089
(408)733-6565
(408)733-6567 FAX

November 1999

This page intentionally left blank

LUMISCAN ACR-2000 SERVICE MANUAL - INTRODUCTION

TABLE OF CONTENTS

INTRODUCTION

Overview.....	v
Reference Documents	vi
Safety Information.....	vii
1.0 PRE-INSTALLATION	1-1
2.0 LUMISCAN INSTALLATION	2-1
3.0 SYSTEM POWER-UP AND OPERATION	3-1
4.0 THEORY OF OPERATION.....	4-1
5.0 SERVICE ADJUSTMENTS.....	5-1
6.0 PERIODIC MAINTENANCE	6-1
7.0 DIAGNOSTICS	7-1
8.0 REPLACEMENT PARTS	8-1
9.0 APPENDIX A	9-1
10. SCHEMATICS	10-1

This page intentionally left blank

INTRODUCTION

OVERVIEW

Product Features

The **LUMISCAN ACR-2000** is a precision instrument designed to scan storage phosphor screens and produce high quality x-ray images over a wide dynamic range with a high signal-to noise ratio. This is accomplished by illuminating the screen with a laser as the screen is moved perpendicular to the laser. The emitted light is collected, converted to an electrical signal and digitized to provide a 12 bit resolution image .

***High Resolution**

***High Positional Accuracy**

A precision galvanometer scanner is utilized to produce a line scan that is perpendicular to the direction of plate travel. This provides the positional accuracy required for high resolution digitizing.

***Precision Optics**

The optical system is designed to provide diffraction limited performance over the scan envelope.

***Proprietary Light Collection System**

This sets the **LUMISCAN** apart from other systems. The light collection system permits collection angles of over 150 degrees at each point, allowing measurements to be extended to low exposure areas. The collection system coupled with the detector electronics leads to a true and precise digital representation of the image information on the plate.

This document contains a basic technical overview of the **LUMISCAN ACR-2000**. The optics, digital hardware, and software subsystems are explained, as well as the systems' functionality and general user operation. Unpacking, hardware and software installation, system specifications, service adjustments and troubleshooting are also included. This document is intended for users who may need to understand the principles of operation for the **LUMISCAN ACR-2000**.

LUMISCAN ACR-2000 SERVICE MANUAL - INTRODUCTION

REFERENCE DOCUMENTS

LUMISCAN ACR-2000 Reader and Eraser Operator's Reference Guide P/N 0070-711

LUMISCAN ACR-2000 Service Manual P/N 0070-715

LUMISCAN LSDT Film Digitizer / ACR-2000 Reader Configuration Guide P/N 0071-434

LUMISCAN ACR-2000 SERVICE MANUAL - INTRODUCTION

SAFETY INFORMATION

Conventions

DANGER

A **DANGER** indicates that personal injury may occur if the user does not perform the procedure correctly.

CAUTION

A **CAUTION** indicates that damage to the product may occur if the user does not perform the procedure correctly.

PRECAUTION

A **PRECAUTION** indicates that inconvenience to the user, such as loss of data, may occur if the user does not perform the procedure correctly.

NOTE

A **NOTE** indicates the information that should be called to the attention of the user.

Be sure to read and understand the installation and operating instructions before applying power to the **LUMISCAN ACR-2000**.

Laser Safety

The **LUMISCAN ACR-2000** incorporates a Red >15mw high-power solid-state laser diode. The covers on the **LUMISCAN ACR-2000** protect the user from direct exposure to laser light. These covers will protect a user only if they are properly installed when the system is being used. Covers must be removed and replaced by properly trained personnel. If the covers have been damaged during shipment or in usage, contact your local service representative for replacement covers.

DANGER

THIS EQUIPMENT EMPLOYS A LASER. LASER RADIATION MAY BE PRESENT IF THE LUMISCAN ACR-2000 IS OPERATED WITHOUT COVERS. AVOID LASER BEAM. DIRECT EYE EXPOSURE TO LASER LIGHT MUST BE AVOIDED.

LUMISCAN ACR-2000 SERVICE MANUAL - INTRODUCTION

FIGURE I-1 LABELS

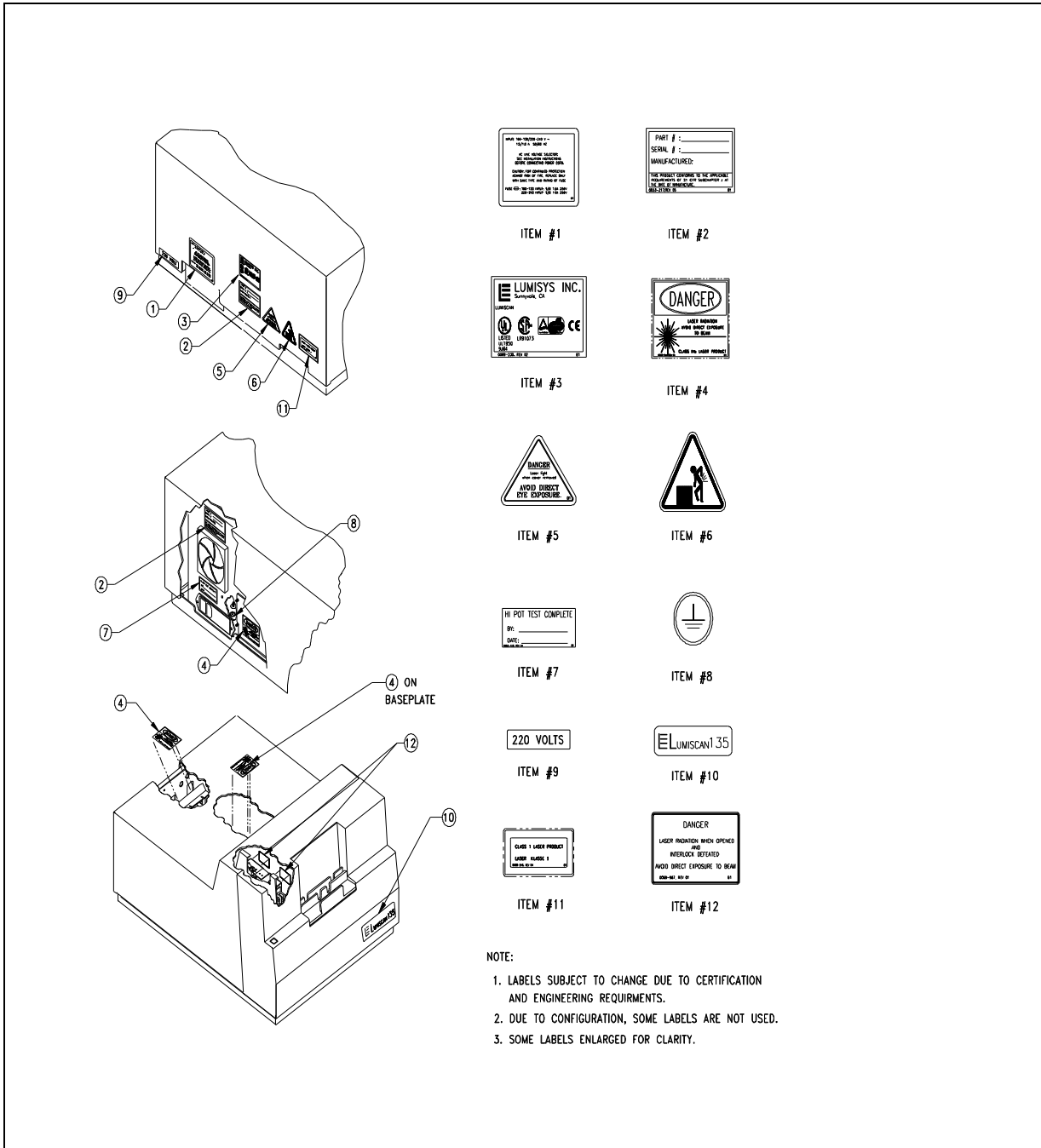

Figure I-2 Label Locations

LUMISCAN ACR-2000 SERVICE MANUAL - INTRODUCTION

Electrical Hazards

WARNING

THIS EQUIPMENT IS OPERATED WITH HAZARDOUS VOLTAGES WHICH CAN SHOCK, BURN OR CAUSE DEATH.

This equipment must be serviced by persons properly trained and certified by **Lumisys**.

DO NOT operate the **LUMISCAN ACR-2000** with a damaged power cord.

Use of an extension cord is not recommended.

This equipment must be properly grounded and power connections inspected to insure safe operation.

FCC Notification

This equipment generates, uses, and can radiate radio frequency energy, and if not installed in accordance with the installation instructions, can cause interference with radio communications.

LUMISCAN ACR-2000 SERVICE MANUAL - INTRODUCTION

LUMISCAN ACR-2000 SYSTEM SPECIFICATIONS

SCAN SIZE	18 x 24 to 35 x 43 cm
PIXELS PER LINE	2048 10" to 14"
SCAN RATE	50 lines/second
GREY SCALE RESOLUTION	12 bits (4096 levels)
INTERFACE	ISA Interface Card With 16 Mbytes Memory
DIMENSIONS	20.5"W x 13"H x 27"D
POWER REQUIREMENTS	100 to 120V, 50/60 Hz, 1.5 Amps 220 to 240V, 50/60 Hz, 1.0 Amps
TEMPERATURE CONSTRAINTS	15 to 35 degrees C - operating -18 to 65 degrees C - non-operating
HUMIDITY	20 to 80% non-condensing
VIBRATION/ACCELERATION	3G Max (in shipping)
ALTITUDE	0 to 10,000 ft. - operating
WEIGHT	85 pounds (125 pounds shipping weight)

1.0 PRE-INSTALLATION

1.1 Purpose

The purpose of this section is to provide the necessary information to efficiently configure a site for the **LUMISCAN ACR-2000** pre-installation. This includes environmental, electrical, and physical parameters.

1.2 Voltage Requirements

The **LUMISCAN ACR-2000** operates at 120 VAC for domestic units. International units operate at 220/240 VAC. To change the voltage of the **LUMISCAN ACR-2000 READER**, follow the procedure in **SECTION 2.0** of the **Service Manual**. The **ACR-2000 ERASER** is permanently configured for 120VAC or 240VAC.

1.3 Environmental

There are several environmental factors to consider when installing the **LUMISCAN ACR-2000 READER**. The basic concerns are ambient light, humidity and temperature.

The ambient light in which the **LUMISCAN ACR-2000 READER** operates is extremely important. The **LUMISCAN ACR-2000 READER** is a **DARKENED ROOM CR** system meaning the ambient light can not exceed Exposure Value (EV) of 2. The room should be light enough to see where objects are, but no lighter. Too much ambient light during a scanning operation will darken images and introduce image artifacts.

Under ***No*** circumstances should the digitizer be placed in a darkroom with a film processor present. This will ***Void the warranty***.

The humidity and temperature limits are 20 to 80% non-condensing, and 15° to 35°C, operating, respectively.

The room should have good ventilation.

Another factor to consider prior to installing the **LUMISCAN ACR-2000** is dust. The **LUMISCAN ACR-2000** contains optics that are affected by dust. In a dusty environment, small amounts of dust and/or dirt may enter the optics module. This dust can affect image quality. To prevent this potential problem, it is recommended that the **LUMISCAN ACR-2000** be installed and operated in a clean environment.

Do not install in a room where laundry or towels are stored. These add lint and dust to the environment

LUMISCAN ACR-2000 SERVICE MANUAL - SECTION 1.0 PRE-INSTALLATION

Flooring should be tile and linoleum only. Carpeting or rugs should not be in the room.

1.4 Physical requirements

The **LUMISCAN ACR-2000** weighs over 75 pounds. It is important the system is placed on a table or stand that can provide adequate and level support.

1.5 Connectivity

The room needs to have a 10 Base T network connection.

2.0 LUMISCAN ACR-2000 INSTALLATION

2.1 Unpacking Instructions

NOTE

INSTALLATION SHOULD NOT BE ATTEMPTED UNLESS THE SERVICE ENGINEER HAS BEEN FACTORY TRAINED

WARNING

THE LUMISCAN ACR-2000 READER WEIGHS OVER 75 POUNDS. IT REQUIRES TWO PEOPLE TO SAFELY LIFT AND MOVE IT.

THE LUMISCAN ACR-2000 READER USES A LASER FOR SCANNING. DO NOT LOOK DIRECTLY AT THE LASER LIGHT.

CAUTION

THERE ARE TWO BRACKETS ON THE BOTTOM OF THE FRONT ENCLOSURE. THEY MUST NOT BE PLACED ON THE TABLE BUT POSITIONED SO THEY HANG OVER THE TABLE TO SUPPORT THE SCREEN EXIT TRAY. THESE BRACKETS WILL BE DAMAGED IF PLACED ON THE TABLE.

2.1.1 Tools Required

A 7/16" open end wrench and a large flat blade screw driver are required.

2.1.2 Unpacking the LUMISCAN ACR-2000 READER

Using the large screw driver, remove the clamp brackets from the bottom of the crate.

Lift the crate off the pallet.

Remove the accessories box.

Remove the plastic bag protecting the system.

Using the 7/16" open end wrench, remove the 4 bolts from each corner of the pallet underneath the

LUMISCAN ACR-2000 READER.

With **TWO PEOPLE**, lift the **LUMISCAN ACR-2000 READER** off the pallet.

To install the **LUMISCAN ACR-2000 READER**, follow the **Hardware Installation Procedures**.

2.2 Hardware Installation

2.2.1 Tools Required

#1 flat-head screwdriver
#1 philips-head screwdriver

2.2.2 AC Voltage

You must verify that the **LUMISCAN ACR-2000 READER** is set up for the correct AC line voltage. This can be checked by looking at power configuration panel which is located just to the right of the power entry plug next to the on/off switch in the rear of the machine. The **LUMISCAN ACR-2000 READER** is set for 120 VAC for domestic units. See Figure 2-1.

If the **LUMISCAN ACR-2000 READER** is to be operated at **200/240VAC** line voltage configuration requires removing and inverting the Corcom fuse module, and the programming card must be changed. *Note: disconnect power before changing line voltages or fuses.* First remove the plastic cover/fuse module by using a small screwdriver to pry out the fuse module(See figure 2-1). Loosen the philips head screw and remove and invert the fuse block and tighten the screw. Two each 1 Amp 250V 5mm x 20mm Slo-Blo fuses should all ready be installed, if not install them. Next remove the programming card rotating it until the desired voltage is pointing inward and rotate the voltage indicator to point outward and reinsert the card. Replace the fuse module and ensure the indicator is pointing to the correct line voltage. The **LUMISCAN ACR-2000 READER** will is now set for operation.

Note

The fuse in the **LUMISCAN ACR-2000 READER** for 100/200 volt operation is a 1.5 Amp 250/75 volt Slo-Blo fuse (Lumisys Part Number 0065-513). The fuses used for 200/240 volt operation are 1.0 Amp Slo-Blo fuse (Lumisys Part Number 0068-487).

The **LUMISCAN ACR-2000 ERASER** comes either in a 120VAC model or a 240VAC model.

2.2.3 Power Cable

The **LUMISCAN ACR-2000 READER** utilizes an international IEC grade connector for the power cable. Systems are shipped with a standard NEMA 5-15 hospital grade cable. This cable requires replacement depending upon the country of installation. Insert the female end into the input power socket.

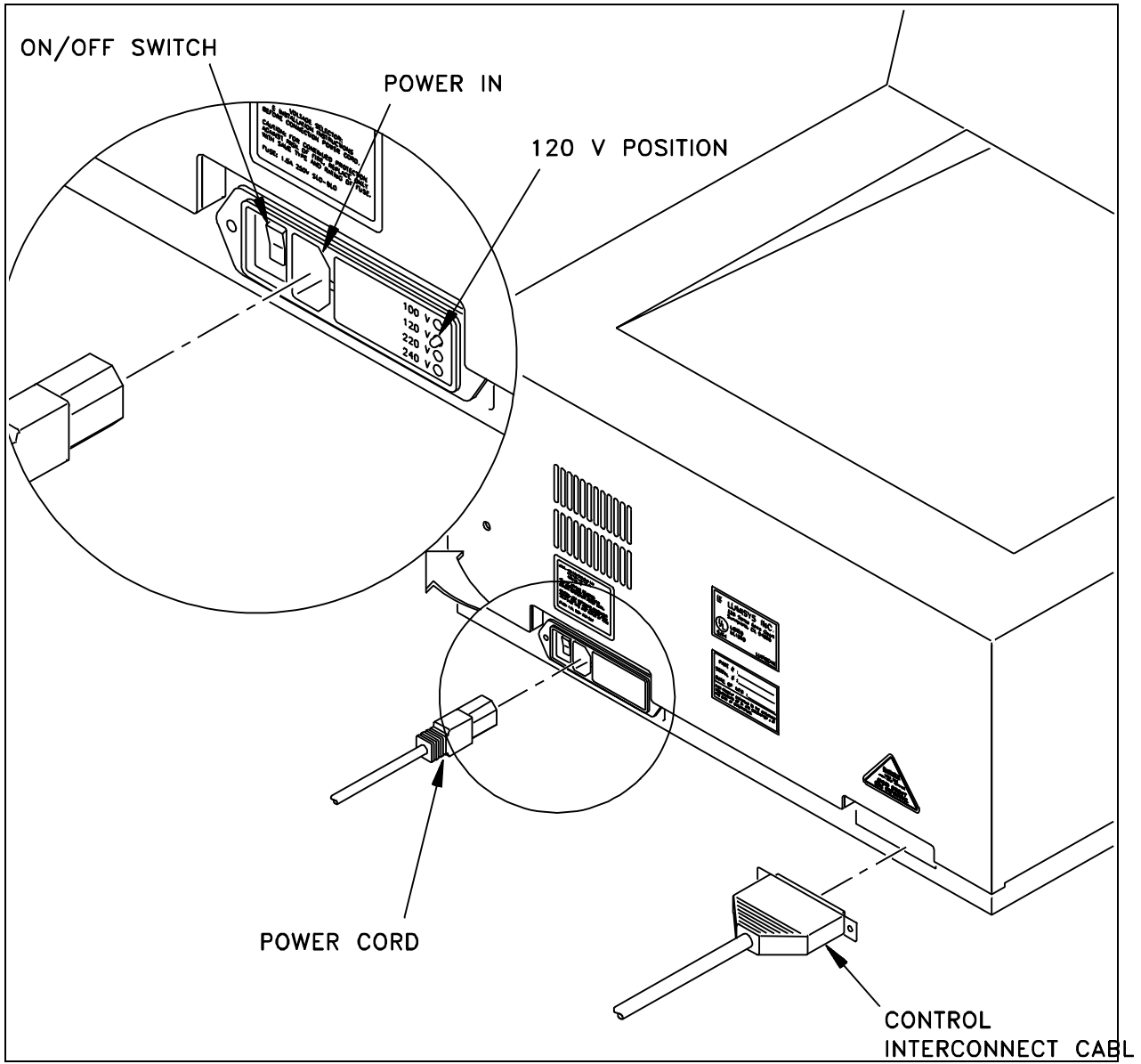

Figure 2-1 Power Switch Location

2.2.4 Media Support Assembly

Fasten the Media Support Assembly to the top of the Front Enclosure.

2.2.5 Screen Exit Assembly

Place the Screen Exit Tray in the brackets on the bottom of the Front Enclosure.

2.2.6 Installation of Data Control Board (DCB)

The ACR-2000 Reader is controlled by a proprietary Lumisys Data Control Board in an IBM type PC. The DCB is 8 bit ISA. The DCB uses three resources, IRQ, Mem Seg Addr, and Base I/O Addr.

Note1: The ACR-2000 product contains a pre-configured PC workstation. It is not necessary to install the Data Control Board unless a different PC is used.

Note2: If a replacement DCB is to be installed in a PC supplied by Lumisys, the PC will likely be set to use certain resources for the DCB. These likely resources are IRQ 7, Mem Seg D800, and Base I/O 100. It is recommended to set the DCB to these resources before installation. Please consult Appendix A for the resource chart.

With power off, remove cover from the target PC or compatible(See Note below). Taking appropriate anti-static precautions, remove the **Data Control Board** from the accessory box and install it in an 8 or 16 bit ISA slot. Secure the **DCB** in the slot and replace the covers.

The **Data Control Board** is factory configured to use **IRQ 5** , I/O Addresses **100-11F** and has a 32 KByte window at hex address **D0000-D7FFF**. If these addresses conflict with your system configuration they may be changed. Please see **APPENDIX A** for instructions on how to change the IRQ level, the I/O address, or the 32 Kbyte window address.

NOTE

The minimum hardware requirements for the Host computer is as follows:

CPU: Pentium II 266MHZ

RAM: 128MB

Operating system: Windows NT 4.0 with Service Pack 4 or higher

Microsoft Internet Explorer 4.01 or higher

2.2.7 Installation of Control Interconnect Cable

Remove the **Control Interconnect Cable** (a 37 pin, Male/Male, D-Subminiature cable) from the accessories box. Connect one end to the **Data Control Board** the other end to the **LUMISCAN ACR-2000 READER** and secure both ends using a small flat blade screwdriver.

2.2.8 Installation of the ACR-2000 Eraser

Remove the ACR-2000 Eraser from its container. The ACR-2000 Eraser provides the means to return an exposed phosphor plate to its ground state and ready for the next patients exam. The eraser can be mounted on the wall by following the separate and included instructions or can be placed on a desktop near an AC outlet.

2.3 Driver Installation

To operate, the **LUMISCAN ACR-2000 READER** software requires you to have WinNT 4.0 installed on your PC and at least 2.0 megabytes of hard disk space available for the creation of a directory and transfer of files from the floppy installation disk. Additional disk space will be required to save digitized images on the disk. Most plates require 2.5 to 10.5 Mbytes of disk space to store the digital image, depending on the plate size and scanning resolution. (low quality 1K or high quality 2K)

The **LUMISCAN ACR-2000 READER** comes configured with an ISA interface. Lumisys provides host computer support software for the **LUMISCAN ACR-2000 READER** configured with the ISA interface.

2.3.1 Correction LUT Files

The Windows NT LSDT driver automatically loads a Correction LUT (CLUT) file during the driver loading process. When shipped from the factory, this file is named CLTXXXXX.DAT where XXXXX is the serial number of the reader the Correction LUT file pertains to. The CLUT file is shipped on the distribution floppy disk. This file is used to calibrate the associated reader and should be used with that reader only.

The CLUT file must be in a specific directory and its name must be specified in the LSDT section of the Registry. Since the file name is specified, multiple CLUT files may be stored in the same directory. See detailed installation instructions below.

2.3.2 DOS, Windows 3.x and Windows 95 and Windows 98 Driver Installation

To install the software, place the floppy distribution disk in drive A. From a MS-DOS prompt type "*a:install*" and then follow the instructions. The installation software will create a directory on the hard disk and transfer the required software from the floppy disk to the hard disk.

Copy the CLUT file (CLTXXXXX.DAT) from the floppy data disk into the root directory, C:\. Be sure to remove any and all other CLUT files from the root. They can be stored elsewhere, just not in the root.

Copy the CAL file (CALXXXXX.DAT) from the floppy data disk into the root directory, C:\. Be sure to remove any and all other CAL files from the root. They can be stored elsewhere, just not in the root.

NOTE

If, when the driver loads, no CLUT/CAL files are found or multiple CLUT/CAL files are found in the root, the driver will default to a 1:1 Correction LUT and no CAL LUT and it will audibly beep.

The device driver **LSDTVxxx.COM** (where Vxxx is the version number) must be loaded by the user for the software to work. To load the driver the user should add the command "*lsdtvxxx*" to the **AUTOEXEC.BAT** or from the MS-DOS command line type "*LSDTVxxx*". Note that in all versions of Windows, if you load the driver from a DOS session, it will only work for programs run from that DOS session, not from programs run from a desktop icon. The driver occupies approximately 17,500 decimal bytes of memory.

Also, it may be convenient to add "C:\LSDT\Tools" to your PATH statement.

NOTE

Information on driver switches used to alter the DEFAULT driver settings are described in **APPENDIX A: ACR-2000 JUMPER AND SWITCH SETTINGS**.

2.3.3 Windows NT Driver Installation

To install the software, place the floppy distribution disk in drive A. Run SETUP.EXE and follow the instructions. The installation software will create a directory on the hard disk and transfer the required software from the floppy disk to the hard disk. It will also create an NTLSDT program group and create or update various registry entries. In the NT Control Panel, a Device will be created called LSDT. The LSDT Device can be configured to start manually or automatically.

Installation types are:

- "Compact" only installs DRIVER, DLL, TOOLS, and LSEXP.EXE
- "Typical" same as "Compact"
- "Custom" by default installs everything, "Compact" plus development files (Custom recommended)

NOTE

Read the README.TXT file included on the distribution disk.

The "\SystemRoot" directory below represents the Windows NT main directory. For example, C:\WINNT (the default), C:\WINDOWS, C:\YOURNAME.

LUMISCAN ACR-2000 SERVICE MANUAL - SECTION 2.0 INSTALLATION

Copy the CLUT file (CLTXXXXX.DAT) from the floppy distribution disk into the directory, '\SystemRoot\system32\drivers'. Use the "LSDT for Windows NT Control Panel" (see below) to enter this filename into the LSDT section of the Registry.

Copy the CAL LUT (CALXXXXX.DAT) from the floppy distribution disk into the directory, '\SystemRoot\system32\drivers'. Use the "LSDT for Windows NT Control Panel" (see below) to enter this table into the LSDT section of the Registry.

NOTE

If the specified CLUT file is not found when the driver loads, the driver will default to a 1:1 Correction LUT and a warning message will be logged to the Event Logger.

2.3.4 Data Control Board Resources

The **Data Control Board** is factory configured to use **IRQ 5**, I/O Addresses **100-11F** and has a 32 KByte window segment at hex address **D000-D7FF**. If these addresses conflict with your system configuration they may be changed. The hardware configuration is determined by a DIP switch and an IRQ jumper on the Data Control Board. Please see **APPENDIX A** for instructions on how to change the IRQ level, the I/O address, or the 32 Kbyte window address.

The most common alternates to the default resources are IRQ 7, I/O Address 120, and Segment Address D800.

If the Data Control Board is reconfigured to use different resources, LSDT Control Panel must reflect the change also.

2.3.5 Software Installation Tips

Windows NT driver disk 2.00 and later

1. It is necessary to have a "Density Correction Lookup Table" installed to achieve accurate density tracking. This file is located on the installation floppy disk. The file format is "CLTXXXXX.DAT" where XXXXX is the serial number of the Reader. This file is installed in the "C:\SystemRoot\SYSTEM32\DRIVERS" directory. *Although more than one different file of this format can be installed, the LSDT Control Panel needs to specify which file is to be used for the particular digitizer in use.*
2. The CAL Table matching the Serial Number of the unit must be installed in the "C:\SystemRoot\SYSTEM32\DRIVERS" directory. The file is in the format "CALXXXXX.DAT".
3. Installing the LSDT NT Software will create in the NT Control Panel a Device called LSDT.
4. The Digital Control Board uses three resources that need to be free. These are Segment Address, IRQ, and Base I/O Address. One, two, or all of these resources can be changed if necessary. These settings are hardware selectable on the DCB.
5. The LSDT Control Panel needs to match the DCB resource hardware settings. The default resources are Segment Address D000, IRQ 5, and Base I/O 100. If these resources are used, it isn't necessary to change the LSDT Control Panel.
6. The most common alternate DCB resources are Segment Address D800, IRQ 7, and Base I/O 120.
7. From the LSDT Control Panel, select the CLT file matching the Serial Number of the Unit.
8. Select the appropriate CAL Table file in the LSDT Control Panel.
9. To verify the driver is installed properly, perform the following steps. Go to a COMMAND prompt. Navigate to C:\LSDT32\TOOLS. Insert a plate. Run the SCANFILE.EXE program. At the end of the scan the number of pixels per line and the total number of lines should be roughly proportional to the film dimensions. As an example, a 35cm x 43cm plate at the default resolution would be 2048 pixels per line and approximately 2500 total lines in the image. If the total number of lines significantly differs from the proper ratio there is probably a Memory Segment conflict. If the plate halts mid scan or doesn't scan there is probably a Base I/O Address conflict. If the plate goes all the way through the system without scanning there is probably an IRQ conflict.

Windows NT (prior to NT driver disk 2.00)

1. It is necessary to have a "Density Correction Lookup Table" installed to achieve accurate density tracking. This file is located on the installation floppy disk. The file format is "CLTXXXXX.DAT". This file is installed in the "C:\SystemRoot\SYSTEM32\DRIVERS" directory. *Although more than one different file of this format can be installed, the LSDT Control Panel needs to specify which file is to be used for the particular digitizer in use.*
2. The CAL Table matching the Serial Number of the unit must be installed in the "C:\SystemRoot\SYSTEM32\DRIVERS" directory. The file is in the format "CALXXXXX.DAT".
3. Installing the LSDT NT Software will create in the NT Control Panel a Device called LSDT. The LSDT Device can be set to start automatically or manually. **Until the proper DCB resources are found, it is recommended that the LSDT Device be set to Manual to prevent the PC from locking when turned on.**

LUMISCAN ACR-2000 SERVICE MANUAL - SECTION 2.0 INSTALLATION

4. The Digital Control Board uses three resources that need to be free. These are Segment Address, IRQ, and Base I/O Address. One, two, or all of these resources can be changed if necessary. These settings are hardware selectable on the DCB.
5. The LSDD Control Panel needs to match the DCB resource hardware settings. The default resources are Segment Address D000, IRQ 5, and Base I/O 100. If these resources are used, it isn't necessary to change the LSDD Control Panel.
6. The most common alternate DCB resources are Segment Address D800, IRQ 7, and Base I/O 120.

To verify the driver is installed properly, perform the following steps. Go to a COMMAND prompt. Navigate to C:\NTLSDT\TOOLS. Insert a plate. Run the SCANFILE.EXE program. At the end of the scan the number of pixels per line and the total number of lines should be roughly proportional to the film dimensions. As an example, a 35cm x 43cm plate at the default resolution would be 2048 pixels per line and approximately 2500 total lines in the image. If the total number of lines significantly differs from the proper ratio there is probably a Memory Segment conflict. If the plate halts mid scan or doesn't scan there is probably a Base I/O Address conflict. If the plate goes all the way through the system without scanning there is probably an IRQ conflict.

DOS or Windows 3.x or Windows 95/98

1. It is necessary to have a "Density Correction Lookup Table" installed to achieve accurate density tracking. This file is located on the installation floppy disk. The file format is "CLTXXXXX.DAT". This file is installed on the C:\ root directory. *There can be only one file of this format installed at one time. Also, the file needs to match the Serial Number of the digitizer.*
2. The CAL Table matching the Serial Number of the unit must be installed in C:\ root directory. The file is in the format "CALXXXXX.DAT".
3. The TSR driver, LSDDVXXX.COM, needs to be loaded for the digitizer to operate. The driver is located in the C:\LSDD\TOOLS directory.
4. The Digital Control Board uses three resources that need to be free. These are Segment Address, IRQ, and Base I/O Address. One, two, or all of these resources can be changed if necessary. These settings are hardware selectable on the DCB.
5. The TSR driver command line needs to match the DCB resource hardware settings. The default resources are Segment Address D000, IRQ 5, and Base I/O 100. If these resources are used, it isn't necessary to change the TSR driver command line.
6. The most common alternate DCB resources are Segment Address D800, IRQ 7, and Base I/O 120.

To verify the driver is installed properly, perform the following steps. Go to a DOS prompt. Navigate to C:\LSDD\TOOLS. Insert a film. Run the SCANFILE.EXE program. At the end of the scan the number of pixels per line and the total number of lines should be roughly proportional to the film dimensions. As an example, a 35cm x 43cm plate at the default resolution would be 2048 pixels per line and approximately 2500 total lines in the image. If the total number of lines significantly differs from the proper ratio there is probably a Memory Segment conflict. If the plate halts mid scan or doesn't scan there is probably a Base I/O Address conflict. If the plate goes all the way through the system without scanning there is probably an IRQ conflict.

3.0 SYSTEM OPERATION

3.1 Power-Up

The power switch on the **LUMISCAN ACR-2000 READER** is located in the lower left corner of the right side panel of the scanner. Two LEDs, one above the other, are located in the lower right corner of the front panel. The top LED is labeled **Power**, while the bottom LED is labeled **SCAN**.

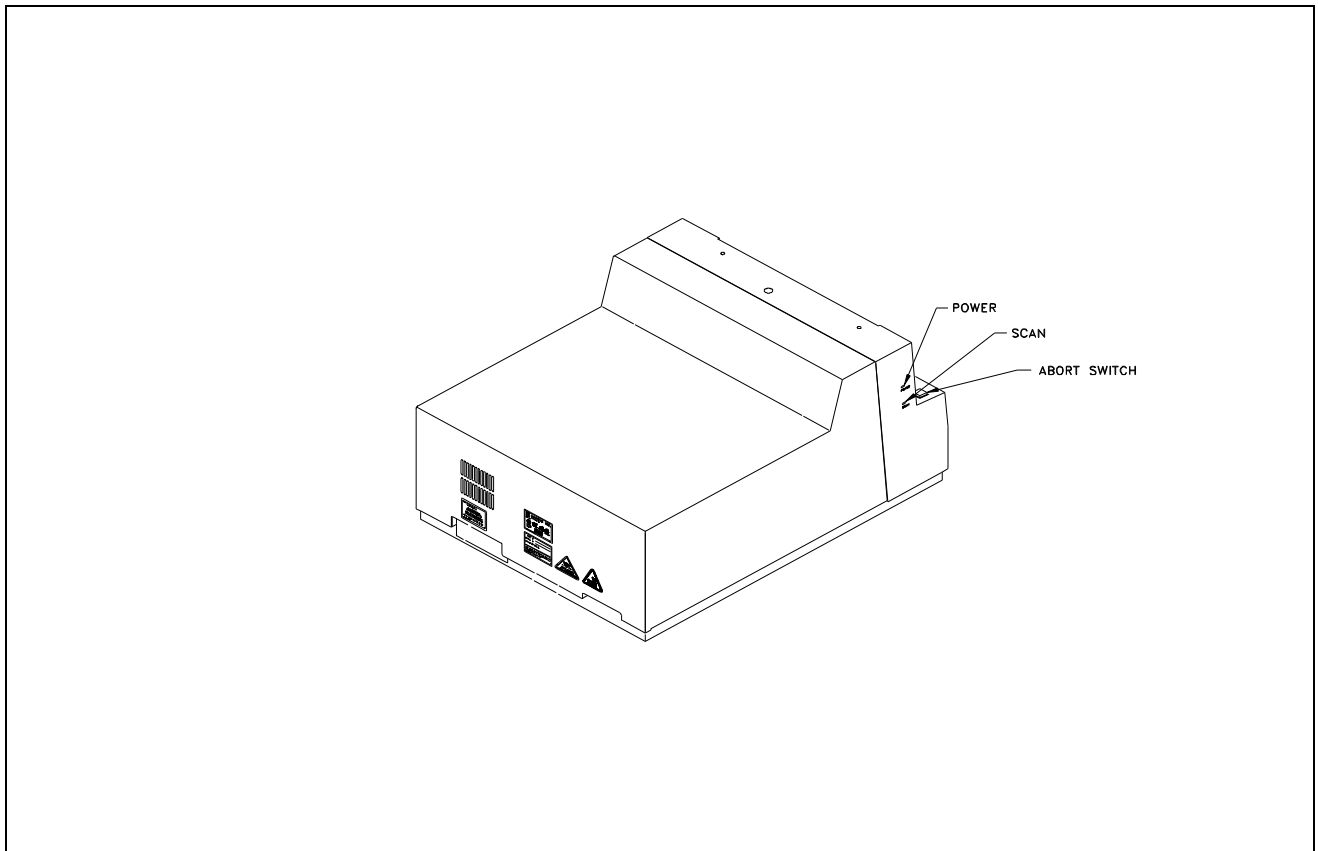

Figure 3-1 LED Locations

When power is turned on, the **Power LED** illuminates. Once the power is turned on, the PC power should also be turned on, booted and the driver installed. The scanner will emit an audible tone when the driver is installed.

NOTE

The **LUMISCAN ACR-2000 READER** should be allowed to warm up for 5 minutes prior to use in order to stabilize the system.

If the scanner is powered off and back on, the host PC driver must be stopped and restarted. This can be done using the “**lsdt**” **Device** in the **NT Control Panel**.

LUMISCAN ACR-2000 SERVICE MANUAL - SECTION 3.0 SYSTEM OPERATION

3.2 Plate Handling and Loading

Processed Phosphor Plates that are to be scanned should be handled carefully to avoid introducing scratches, fingerprints and/or static.

The physical process by which storage phosphors work does not change or, “wear out”, over time. Consequently, the lifetime of the storage phosphor screens is dependent on how carefully they are handled. Dust, fingerprints and scratches on the plate may be visible in the x-ray images and degrade their quality. For plate cleaning instructions, refer to Chapter 6.

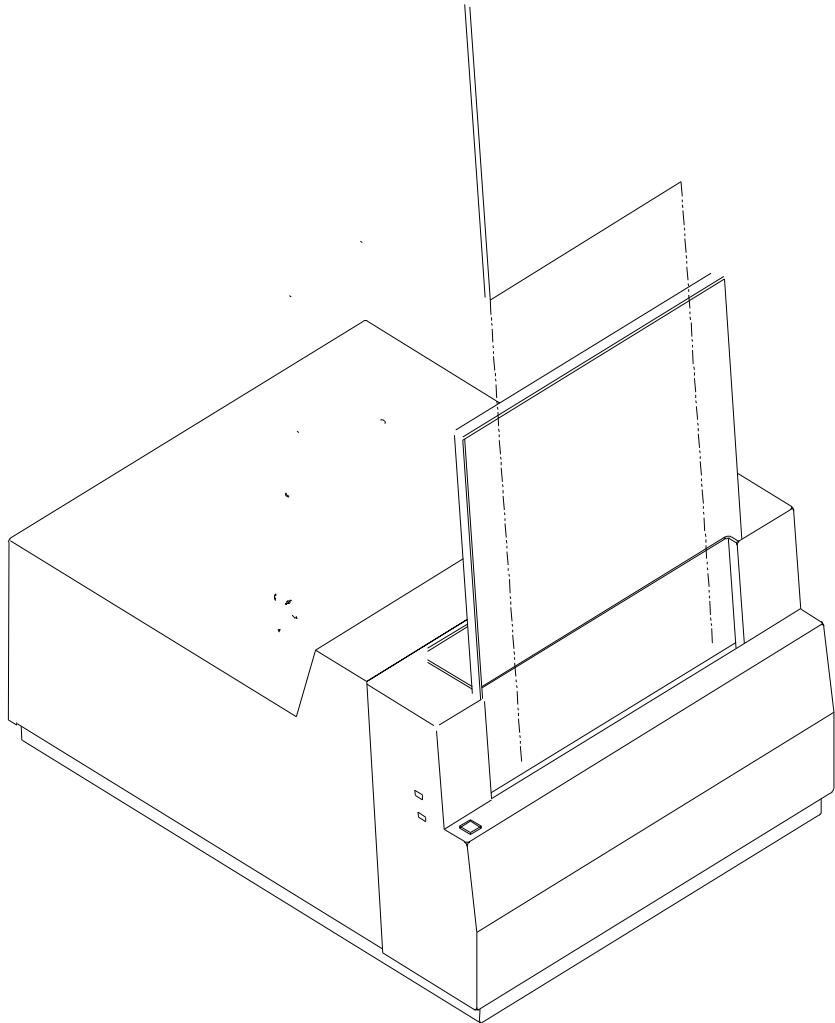

LUMISCAN ACR-2000 SERVICE MANUAL - SECTION 3.0 SYSTEM OPERATION

Handle plates with powder-free latex gloves.

Clean plates every day or after every 10 scans. Use Anhydrous Ethyl Alcohol applied with laboratory grade lint free paper towels.

Clean the input guide and output tray with anti-static guard spray every day.

3.3 Technique

The Lumisys ACR-2000 is a roughly 200 speed system.

If only CR images are acquired, Phototimers should be adjusted for CR exposures. This is because the speed of the system and because CR cassettes attenuate x-rays differently than conventional screen-film cassettes.

3.4 Scanning A Plate

Once a plate has been placed into the image plate-input guide, the user may initiate a scan. Once started the image plate will be moved into position, the edges found and the image plate digitized.

To digitize a plate you may use the DI-2000 Acquisition Application which is installed on the ACR-2000 Workstation. Please reference the DI-2000 Users Reference Guide which is located in the C:\DI-2000 directory.

You may also use the sample scanning program called "SCANFILE.EXE", which is located in the "C:\LSDT32\TOOLS" directory.

From the command prompt type "SCANFILE <cr>".

A image plate will be digitized in a Lumisys format using all default parameters and the results placed in a file called LSDT.IMG.

WARNING

THIS EQUIPMENT EMPLOYS A LASER. LASER RADIATION MAY BE PRESENT IF THE LUMISCAN ACR-2000 READER IS OPERATED WITHOUT COVERS.

AVOID LASER BEAM. DIRECT EYE EXPOSURE TO LASER LIGHT MUST BE AVOIDED.

This page intentionally left blank

4.0 THEORY OF OPERATION

4.1 Product Overview

The **LUMISCAN ACR-2000 READER** is a single-image plate laser scanner designed to scan and digitize the latent image from medical storage-phosphor image plates. The system is based on a fixed size scanning spot and can scan up to 2048 pixels across image plates of 18 to 35 cm in width. This is achieved with a high intensity spot of light derived from a high-power red laser diode which is scanned across the image plate surface as the image plate is moved perpendicular to the beam scan. The stimulated light is collected and digitized to provide an image file that can be stored on disk, transmitted to other systems for processing and manipulation, archived, and/or printed back film.

The **LUMISCAN ACR-2000 READER** is a basic scanner with no image plate handling and is intended to be used in a *darkened room environment*. The image plate must be removed from the cassette and placed into the feed slot in order to be scanned. When the scan is complete the image plate must be removed from the exit tray and erased by placing into the external eraser, then reloaded into its cassette for the next use.

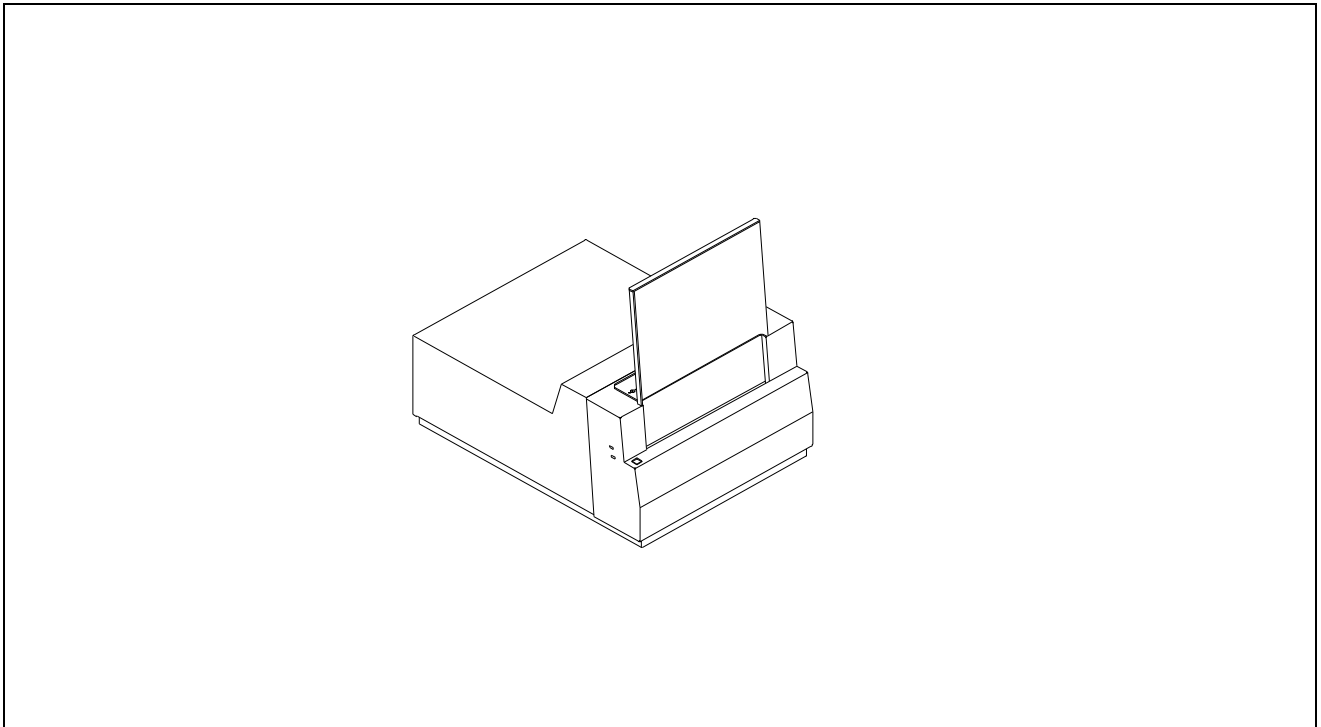

Figure 4-1 Lumiscan ACR-2000 READER

4.2 System Configuration

The configuration of the **LUMISCAN ACR-2000 READER** includes optics, electrical and power supply assemblies, PCAs for scanner control and data acquisition, and a plate transport assembly.

4.3 Optical Beam Path

The **READER** contains a laser, laser power supply, fixed optics and mirrors, a scanning galvanometer, light detection system and a electronics subsystem for control.

The **READER** uses a red, high-power solid-state laser diode (about 35 mw at 658 nm) as the beam source. The laser diode energy is coupled into a single-mode fiber which is then focused through a lens to produce a very high-quality spot. The beam is deflected by a galvanometer scanner to produce the sweep. The folding mirror bends the beam so as to sweep the beam horizontally across the image plate as the image plate travels vertically. See Figure 4-2.

The beam passes through the integrating collection cylinder and strikes the phosphor surface of the image plate. The red light striking the image plate stimulates blue emission from the image plate in proportion to the X-ray energy stored in the image plate as a result of the exposure. This blue light is collected by the integrating cylinder. The red light is blocked from reaching the photomultiplier tubes by blue glass filters. The collected blue light is detected by photomultiplier tubes, which convert the photons into a signal. This signal is then logarithmically amplified, corrected for spatial variations in the system sensitivity across the width of the screen, and then digitized by an A/D converter.

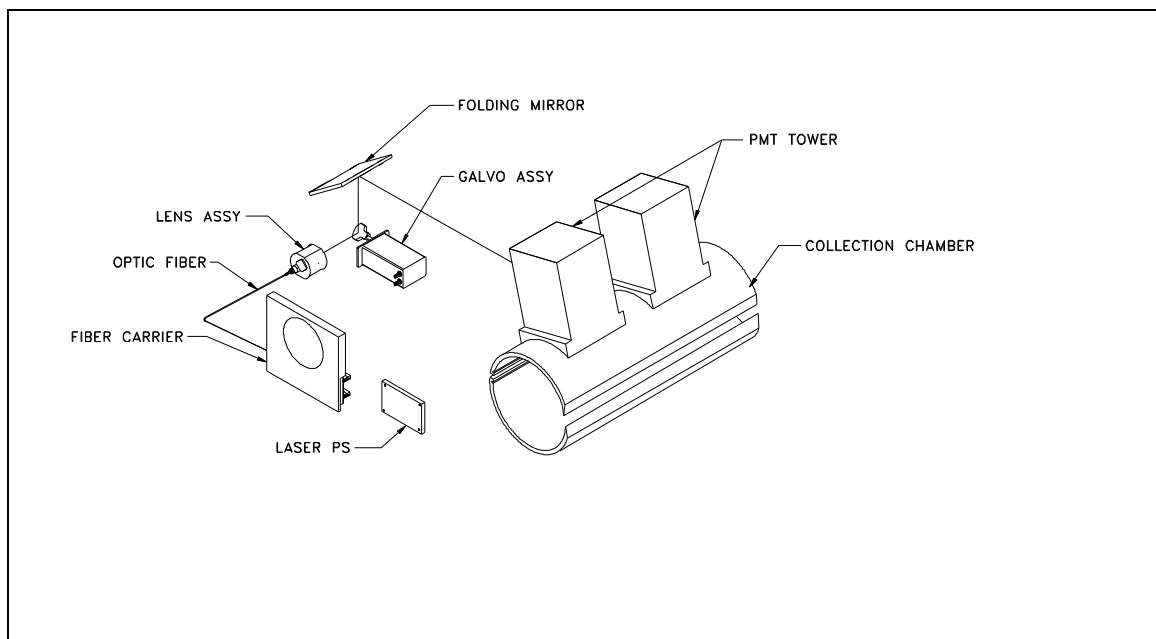

Figure 4-2 LUMISCAN ACR-2000 READER Optical Beam Path

4.4 Digital and Electrical Systems

The electrical subsystem of the **LUMISCAN ACR-2000 READER** consists of the **Data Control Board**, (DCB), that is located in a PC-type host computer an interconnecting cable to the **LUMISCAN**, and the scanner, which houses six printed circuit boards. These include:

Data Acquisition Board (DACQ),
PMT PreAmp Board,
Galvanometer Board,
Indicator Board.
Indicator/ff Interface Board
Reference LED Board

4.4.1 Data Control Board

All operations are controlled by the **Data Control Board** via means of control registers. Although some of these registers are physically located on the Data Acquisition Board, they are accessed through the Data Control Board. Once a scan is initiated, data acquisition is automatic, requiring no intervention until the image has been written into image memory on the Data Control Board. Image data can be transferred out of image memory during or after image acquisition. The Data Control Board receives its power from the host computer. No power is transmitted over the interconnect cable.

4.4.2 Data Acquisition Board

The **Data Acquisition Board** performs all the signal conditioning and data acquisition functions, including calibration and lookup table functions.

4.4.3 PMT PreAmp Board

The **PMT PreAmp Board** contains the first stage preamplifier. This board provides power connection, a high voltage divider network for the PMT tubes and a first stage amplifier for the PMT signals.

4.4.4 Galvanometer Board

The **Galvo board** contains a high-accuracy feedback servo amplifier for controlling the position of a mirror mounted on the shaft of a scanning galvanometer. Position feedback is from a sensor integral to the galvo. The galvo motor shaft oscillates back and forth through an arc of approximately 30 degrees at a rate of 50Hz. A small mirror attached to the shaft intercepts the static laser beam and sweeps (scans) it across the width of the image plate. It important that the Galvanometer Board be adjusted so that the beam scans across the plate at a consistent speed. Proper performance of the Galvo PCB is dependent upon the adjustment of several of its potentiometers.

LUMISCAN ACR-2000 SERVICE MANUAL - SECTION 4.0 THEORY OF OPERATION

4.4.5 Indicator Board

The **Indicator Board** contains two LED indicator lamps which are used to signal scanner power ON and SCAN status. The SCAN indicator is turned on only while a scan is in process; it also blinks whenever the plate is in the optical path.

4.4.6 Indicator/FF Interface Board

The **Indicator/FF Interface Board** provides an adjustable drive circuit for the Reference LED Board.

4.4.7 Reference LED Board

The **Reference LED Board** provides a means of mounting the blue reference LED and a connector. The blue LED provides a consistent reference signal for purposes of self-alignment by the electronics.

This page intentionally left blank

4.5 Sub-System Operation

4.5.1 DATA CONTROL BOARD (DCB)

The DCB is a standard size PC/XT board occupying 32K bytes of memory space and 24 bytes of I/O space. It supports 8-bit data transfers only and has multiple interrupt capability. The physical memory consists of a single, 72-pin SIMM with 16MB.

Image memory is accessible through a 32KB window. This window can be positioned on any 32KB boundary within the standard 1MB DOS address space by means of five DIP switches on the DCB. Memory page selection is accomplished through a Bank register.

The image memory is accessible at all times including during image acquisition. An arbiter controls access, giving the data writes priority over bus access. If necessary the PC bus IOCHRDY signal is asserted to delay the bus access. The image memory should never be written to from the bus during image acquisition.

During image acquisition a separate 24-bit counter selects sequential byte addresses for each data write; counting always starts at address zero. Address counting is only enabled when SCAN is true, and is reset to 0 when SCAN changes from false to true. The counter can be read at any time.

The control registers are mapped into the I/O addresses 100 hex through 117. These locations are fixed and can be changed only by changing the firmware. The DCB allows the selection of three alternate mapping of the I/O registers by means of a DIP switch.

In addition to image memory there are 64KB of memory on the Data Acquisition board which are accessible through the DCB. This memory is where the calibration and lookup tables are located and is fully R/W accessible, but only while not scanning. Access is sequential through a 16-bit I/O register. The memory is organized on the Data Acquisition board as eight tables of 4K x 16 bits each. The sequential access can begin at the beginning of any one of the eight tables by means of a 3-bit LUT bank select field and an Autoincrement Reset bit. Accesses can extend beyond the selected bank; the bank register will autoincrement also.

The DCB can interrupt at levels IRQ3 through IRQ7 (jumper selectable). There are four possible interrupt sources; each one can be separately enabled and cleared.

Control During Scanning

During the scanning process the DCB generates the timing and synchronization signals and transfers the image data into image memory as it becomes available. There are three clock generators and three counters: Scan Clock, Film Clock, Pixel Clock, Delay to 1st Pixel count, Pixels per Line count, and Lines per Image count. These are each described briefly below.

The **Scan Clock** is a continuous clock signal derived by dividing 10Mhz. It is used to control the line scan repetition rate and to synchronize the beginning of each scan sweep (Start of scan, or SOS). The actual linear rate during each sweep is controlled by the Data Acquisition board. For the **135** the Scan clock is set for a 50 Hz scan rate and should never be changed.

The **Film clock** is a continuous clock signal derived by dividing 10Mhz. It is used as the reference for a frequency-controlled servo motor driver which controls the film transport motor. The plate speed is directly proportional to this frequency.

The **Pixel Clock** is a gated trigger signal derived from 40Mhz. The trigger signal is sent to the DACQ during each scan line after the completion of the Delay to 1st Pixel count and until the completion of the Pixels per Line count.

The **Delay to 1st Pixel** counter counts the Pixel clocks, beginning at SOS (Start of Scan) and terminating when its preset count is reached.

The **Pixels per Line** counter is enabled at the termination of the Delay to 1st pixel count and counts Pixel clocks, terminating when its preset count is reached. If enabled an interrupt request will be generated at count termination.

The **Lines per Image** counter is enabled at the beginning of a scan and is incremented at the end of each scan line, terminating when its preset count is reached. If enabled an interrupt request will be generated at count termination. The usual value for this counter is 65,535 (maximum), which effectively disables this control and permits the Isfilm (plate present status) signal to be used to control acquisition.

Interrupt Requests

There are four possible sources for interrupt requests by the DCB: Last pixel in line, Last line in image, Change in Isfilm (film entering or leaving optical path), and Event 0, which is used for the Abort switch. Each can be independently enabled and cleared.

4.5.2 DATA ACQUISITION BOARD (DACQ)

The DACQ board performs all of the signal conditioning and data acquisition functions, including calibration and output table lookup. In addition it generates the Galvo sweep control waveform and provides the Film Motor control and drive.

The DACQ is optimized for digitizing image plates up to 14" wide with a resolution of 2048 pixels/line (146 pixels/inch) and can accommodate increased resolutions with smaller plates (e.g. 256 pixels/inch across a 8" image plate

Most of the digital logic on the DACQ board is contained in two large Programmable Logic Devices and a Digital Signal Processor. These are ICs which are SRAM-based and must be downloaded with code before they become functional. The DSP downloads or boots at power-on and each time a DACQ function is initiated. However at power-on and after the DSP boots, it then also downloads the two PLD's with their code. If for some reason the download fails to complete, the board will be nonfunctional.

Signal Conditioning

The analog signal path consists of a logarithmic amplifier. The log amp is of a special type that does not depend on a semiconductor junction but rather a resistor ladder network. It has inherently high stability, dynamic range and bandwidth and depends only on resistor values for accuracy. In addition there is a proprietary self-adjustment circuit which is controlled by the DSP and acts to maintain the low-level signal accuracy.

Start/end of Film Detection

The Start/End of Film (ISFILM) detector is a photodetector which is located at the cylinder slot such that it is in the path of the laser sweep when there is no image plate present, which results in a pulse signal. This signal is blocked while the image plate is being scanned; ISFILM is defined as the absence of this pulse. Note that if the laser is not on or the sweep is misaligned such that it does not strike the detector then this will be interpreted as ISFILM being true.

Acquisition Control

The acquisition process begins with the initiation of an A/D sample output of the log amplifier. Control is primarily by the DSP device (DQDSP.DSP), in conjunction with PLDs (DQCTRL.TDF and DQDSPIF.TDF). A pixel acquisition sequence is initiated by each PIXTRIG signal from the Data Control Board. The function performed for each pixel depends on the Mode which is selected in the DACQ CSR. During acquisition, the functions may include from one to three lookup table steps and a check of the data against upper and lower limits.

LUMISCAN ACR-2000 SERVICE MANUAL - SECTION 4.0 THEORY OF OPERATION

In all modes the acquisition process ends with the writing of data into the output register and assertion of the signal DATAVAIL to the DCB. The DCB then transfers the data into the image memory depending on the following; the Mode, the state of ISFILM, the state of the Pixel counter and the state of the Line counter.

Calibration and Table Lookup

The three possible Lookup table functions are: Correction LUT, Calibration LUT and Output LUT.

The **Correction LUT** is used to correct any deviation of the logarithmic amplifier from a true logarithmic characteristic. It is applied immediately after the A/D results are read.

The **Calibration LUT** is used to compensate for variations in the sensitivity of the system with respect to the horizontal scan. It is generated by scanning a uniformly exposed 14" wide image plate, averaging a number of lines and normalizing the data. This forms a reference look up table with a value for each pixel in a line. This data is truncated and scaled to provide the calibration curve for any size image plate scanned at any allowable number of pixels per line. During acquisition each pixel value from the A/D is added to its corresponding calibration LUT value. Since this addition is of the log of the signals the effect is the same as multiplying the pre-log signal by a scaling factor.

The **Output LUT** is for user use and depends on the application. The default table is a 1:1 Lookup Table. It can be replaced by an inverse 1:1, a 12-bit to 8-bit mapping, or any other desired function.

Automatic Gain Adjustment

Automatic Gain Control is used to compensate for reduction in sensitivity of the PMT detectors due to age. Automatic gain adjustment (AGC) is performed whenever a DACQ mode 5 command is received. The DACQ Mode 5 is a special mode exclusively for the automatic adjustment of the output gain of the PMTs, as well as automatic adjustment of the log amplifier input offset voltage. The only data generated are the results of the adjustments. The appropriate enable bits must be set in the DACQ CSR for the adjustments to take place, or else the adjustments will be set to null or minimum. When the AGC enable bit is set the HV register specifies the gain to adjust to. The gain may be set to a calibrated level over a range of two decades (2000 counts).

Because there is no signal without the presence of an exposed phosphor image plate a special blue reference LED is incorporated into the collection cylinder which is under firmware and software control. During setup the LED is adjusted for a calibrated, constant light output. Then, during the AGC process the blue LED is turned on and the PMT high voltage is changed so as to produce the desired A/D output. Because the laser produces no signal the galvanometer need not be scanning.

LUMISCAN ACR-2000 SERVICE MANUAL - SECTION 4.0 THEORY OF OPERATION

X Only and XY Pixel Averaging Modes

The **ACR-2000 READER** Data Acquisition board is capable of averaging pixel values together, either in X only or in both X and Y. The mode bits are selected in the DACQ CSR. In X-only mode one data value is produced for each two pixel clocks (one DATAVAIL per two PIXTRIGs). The data value is the average of two samples. Thus the amount of data is reduced by two, and the film speed should double in order to maintain a 1:1 pixel aspect ratio.

In XY averaging mode two lines are averaged in addition to the pixel averaging described above. Thus each data value is the average of four adjacent pixels (2x2) and the amount of data is reduced by four. In this case the film speed is the same as for no averaging.

Galvo Control

Control of the galvo in the **ACR-2000 READER** is different from control in the LS100/200 series in that the basic sweep and retrace times are not programmable. These parameters are fixed in firmware; the PLD must be changed in order to change these parameters. The present settings are 480 kHz up clock (8.53ms up ramp) and step return to start (no down ramp).

The SCANCLK signal from the Data Control Board no longer controls the sweep speed. The sweep speed is now fixed within the generation circuit (DQFMGV.GDF) and can be changed only by changing the firmware. The SCANCLK signal now controls the repetition, or line, rate. This is fixed for each model and should never be changed.

For the **ACR-2000 READER** the Scanclk frequency is $10,000,000/25000 = 400\text{Hz}$. This signal is always sent by the DCB; active galvo scanning is enabled by the Galvo Enable bit in the DACQ CSR.

This is divided by 8 in DQFMGV.GDF, which generates the SOS signal. Thus the scan synchronization begins here. The SOS signal initiates a galvo sweep and also is sent back to the DCB to begin the line acquisition sequence.

The Galvo board is now a more standard servo control amplifier and the interface is simpler. The sweep is linearized with a lookup table (GLVLUT.DAT) which converts the linear stairstep output from the generation circuit into an S-shaped waveform. The amplitude and DC offset of the output signal can be varied by two on-board potentiometers.

Galvo Rest Positions

If the SCANCLK signal is present and the GLVENB bit is set in the DACQ CSR, then the galvo sweep signal will be generated, causing the galvo to sweep. If the GIVENB bit is cleared the galvo will stop sweeping and will take a static position according the settings of the "PARK" switches and the "CTR" jumper. If the CTR jumper is installed the position will be at count = 2048, which is the electrical midpoint of the sweep. This is irrespective of the setting of the PARK switches.

LUMISCAN ACR-2000 SERVICE MANUAL - SECTION 4.0 THEORY OF OPERATION

If the CTR jumper is off and the GIVENB bit is cleared then the position will be according the PARK switches, which consist of 6 DIP switches. The position will be equal to the switch value 0 through 4032. (0 through 63 times 64). The beam can be parked at any location within 64 counts by setting the switches.

Film Transport Motor Control

The **ACR-2000 READER** film transport motor is a precision DC motor with a 256-count encoder. The control for this motor is on the Data Acquisition board. It is a frequency-controlled servo amplifier, with the reference frequency, FILMCLK, coming from the DCB. The linear plate speed is directly proportional to the FILMCLK frequency. As with the galvanometer control this signal is always being generated by the DCB; motor drive and direction are controlled by two DCB CSR bits, Motor Enable and Film Reverse. There are no adjustments to the plate transport motor control circuit.

Speed is set by an input clock rate between 9khz and 16khz, which accommodates the necessary range of plate speeds. When the Motor Enable bit is set to 1, the input clock signal is compared with a motor encoder signal. The input clock signal causes a counter to count up, the encoder rate signal causes the same counter to count down. The residual count is converted to an analog voltage via a Digital to Analog Converter to drive the motor. When the motor(encoder) rate matches the desired input clock rate, zero servo error and speed stability is attained. Plate reversal is performed by changing the polarity of the servo signal when the motor reverse signal is activated.

Interface to the Data Control Board

The interface between the DCB and the DACQ is by a 37-conductor cable. The signals include a bi-directional 8-bit data bus, status signals from the DACQ, and control signals from the DCB.

The DACQ is a slave in all data transfers. There are two types of data transfer: DACQ register R/W and DCB image memory write during data acquisition. During data acquisition the DACQ signals the DCB when a data word is available (DATAVAIL) and then the DCB reads the data a byte at a time over the interconnect, writing it to the image memory with the autoincrement address counter setting the address. The signal (SCAN) must be true for data transfer to occur, which is automatic. Also the status signal ISFILM must be true in order for the DACQ to assert DATAVAIL.

DACQ register access includes the DACQ CSR and the Ca/LUT autoincrement memory SCAN must be false for this to occur.

LUMISCAN ACR-2000 SERVICE MANUAL - SECTION 4.0 THEORY OF OPERATION

4.5.3 PMT PREAMPLIFIER

The preamplifier is the interface between the PMT receiving the stimulated light from the collection chamber and the log processing circuits in the Data Acquisition PCA. The preamplifier serves as a current to voltage converter between these two assemblies.

The preamplifier is a single integrated amplifier with the input power and common return provided from the Data Acquisition PCA. The input power is filtered at the amplifier and reverse bias diodes are provided to protect the circuit against improper connections of the input power. High voltage from a PMT supply is divided in 10 equal differential voltages and used to bias the cathode, grid, and 8 dynodes of the PMT.

This page intentionally left blank

5.0 SERVICE ADJUSTMENTS

This section covers the **LUMISCAN ACR-2000 READER** components that can be adjusted in the field.

The following equipment is required for any alignment or adjustment performed in this section of the service manual.

Requirements

HARDWARE REQUIRED

Computer with keyboard and monitor
Interconnect cable, PN 0062-052
Data Control PCA (DCB)
Oscilloscope, 50 Mhz, dual trace or better
Digital Volt Meter(DVM)
Imaging workstation
DVM
Laser power meter, Photodyne or equivalent
Storage phosphor image plates, 14 x 17inches, Agfa, Kodak or Fuji
Interlock switch cheat keys, 2 each
X-ray system capable of 85 kVp at 8 mAs
X-Ray exposure meter (capable of discerning 0.05 milliRads)
Copper step wedge, .020" x 8 steps
Copper plate (1mm thick)
Set of Standard Screw Drivers(Flat blade, philips)
Small Screw Driver(Tweaker)
Hex Driver Set (5/16 thru .050)
Photographic Dark Cloth Cover
Diagnostics
Galvo Linearity Pattern P/N 0070-966

SOFTWARE REQUIRED

Lumisys diagnostic and calibration tools must be available. These are typically found in the C:\LSDT32\TOOLS directory. The Data Acquisition (DACQ) board must also have its associated CLUT file available, as generated during board-level testing.

WARNING ACR-2000 READER

Working with and around X-ray equipment and high-power lasers present risks if proper precautions are not taken. The X-ray equipment is housed in a lead-lined room. Never turn the X-ray on unless all personnel are outside of the room and the door is closed. Perform the following steps in a darkened or dimly lighted room so as not to damage the PMT.

5.2 Optics

This procedure contains complete field optical alignment instructions for the LUMISCAN.

NOTE

Laser light is present. Observe all warnings and cautions listed in the Introduction, Installation and Maintenance sections of this manual.

Any component change in the optical path will probably require re-alignment and adjustment of all subsequent elements, from that point on, to the PMT sub-system.

All optical surfaces are sensitive and delicate. Follow the **Optics Cleaning** instructions in this Section of the manual.

5.2.1 Optical Adjustments

Optical Adjustments NOTE

The following alignment procedures are not required unless a component used in the procedure has been replaced. Alignment should not be attempted unless the service engineer has been factory trained.

The following is a list of the Optical adjustments. See Figure 5-1.

- Laser Diode Module assembly
- Galvo Scanner
- Folding Mirror

Remove the LUMISCAN main cover to gain access to the Optics. (Refer to **Section 8.0** of this manual).

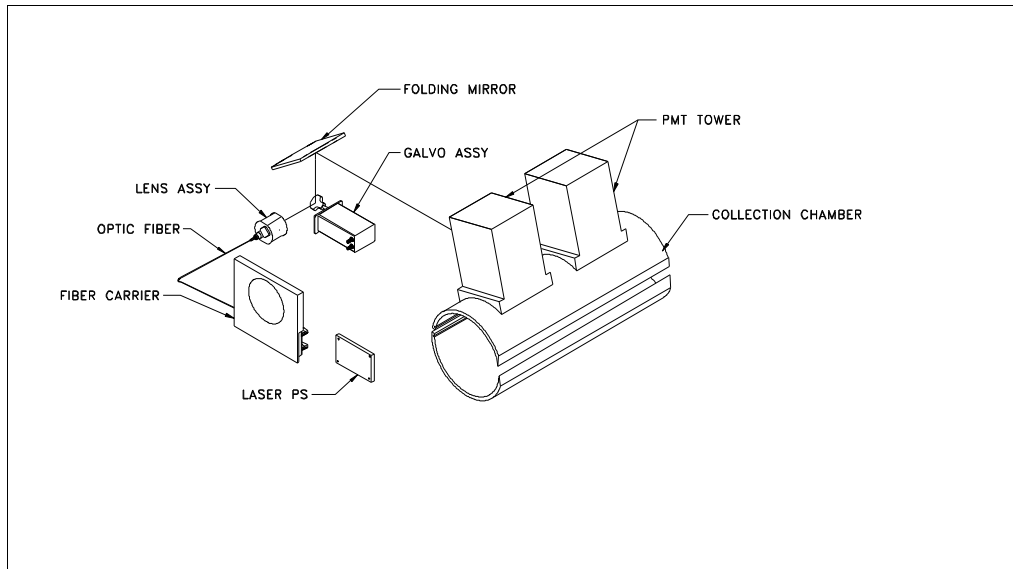

1. Laser Light Verification

Install the Interlock Key to allow operation of the Laser with the cover off. Remove the optics cover on the back panel. Turn on the ACR-2000 Reader. Observe that the beam is projecting onto the Galvo Mirror. If the power is on and the Interlock Key is installed and there is no Laser light, the Laser Module is suspect.

2. Folding Mirror

Disconnect the **J3** power cable to the Galvo PCA. Ensure that the beam is projecting to the center of the Light Collection Chamber +/- **0.5** inches. If not, rotate the Galvo Motor or the Galvo Mirror to achieve center. Re-connect the Galvo PCA power. Go to the command prompt. Navigate to the Lumisys “tools” directory. Start the **DDT** menu. Start the Galvo by selecting option **20** from the **DDT** menu. Adjust the height and the tilt adjustment screws that are located on the folding mirror until the beam is horizontally centered and vertically level in the Light Collection Chamber opening. Remove Galvo PCA power at **J3**. If the beam is not horizontally centered, start step **2** over again.

3. Plate Detector Alignment

*Note: This adjustment applies **only** to readers with Data Acquisition PCA P/N's 0070-735 and below. This adjustment is **not** necessary for readers with Data Acquisition PCA P/N's 0071-592 and above.* Go to the command prompt. Navigate to the Lumisys “tools” directory. Start the **DDT** menu. Select option **20**. Press “**T**” to measure the “Isfilm” signal. Press “**P**” to plot the “Isfilm” signal. You should see three spikes approximately 1600 in amplitude. If these spikes are not seen, the beam is not hitting the three detectors. Use the roof mirror to raise or lower the beam until all three spikes are visible.

5.3 Scan Linearity Adjustment

NOTE

This Adjustment Must be done in a Darkened Room

NOTE

Adjustment of the Scan Linearity is rarely necessary. For various reasons, the Linearity Test can sometimes provide a false indication of failure. Test results which are slight out of tolerance are probably genuine. Test results which are far out of tolerance are likely false. The most common reason for false Test results is too much ambient light leaking into the unit. Be sure to verify that the Scan Linearity is failing before making any adjustments

This adjustment will assure that the reading of a single line of data occurs within the most linear region of a given Galvo motor sweep, and that the edges of the film do not fall outside of the scan range.

The test pattern used in this adjustment has 14 evenly spaced bars of equal width. **R45 Damping** and **R47 Servo Gain** on the **Galvo PCA** are used to adjust the rate of beam movement across the 14 bars so that the number of pixel samples on each bar is the same. If the beam moves too slowly across a bar the number of pixel samples will be too high. This error is quantified by the **LNADJDT** program as **CAL+**. Conversely, too few pixel samples result in **CAL-** error. **R58 Galvo Offset** is used to position the beam so that the 14 bars are centered in the beam span. **R59 Galvo Span** is used to adjust the beam span so that the sum of the 14 bar widths is a specified value called **Sum of Deltas**, which is the sum of the pixel samples of the 14 bars. The field specification for these parameters is as follows.

Nominal Parameters

Cal + error: less than **2%**

Cal - error: less than **2%**

Sum of Deltas: 3902 \pm 1

Distance to first edge: 86 \pm 1

Preferred Parameters

Cal + error: less than **3%**

Cal - error: less than **3%**

Sum of Deltas: 3902 \pm 8

Distance to first edge: 86 \pm 3

Allowable Parameters

Cal + error: less than **5%**

Cal - error: less than **5%**

Sum of Deltas: 3902 \pm 20

Distance to first edge: 86 \pm 7

5.3.1 The room lights should be dim and the unit covered to minimize stray light.

LUMISCAN ACR-2000 READER SERVICE MANUAL - SECTION 5.0 SERVICE ADJUSTMENTS

5.3.2 Place the 14" Linearity Adjust Pattern (P/N 0070-966) in the input slot with the vertical lines facing the unit and the widest red bar towards the abort button.

5.3.3 From the "tools" directory, enter LNADJDT at the command prompt. Enter the Serial Number of the reader. Press <Enter> to continue. When prompted for Lines to Skip, press <Enter>. Observe the following screen display.

```
LINEARITY ADJUST TEST, Lumisys, Inc. (c) 1994
SN: xxxx Model: LSxx Target Delta sum: 3902 1st Edge: 86
```

```
Delta: 276 277 278 277 280 279 281 280 280 279 280 278 278 279
Marks: 1 2 3 4 5 6 7 8 9 10 11 12 13 14
CAL- = 1.00%, CAL+ = 0.79%
sum of Delta's= 3902, average of Delta's = 278.10
Number of edges found = 15 Distance to 1st edge = 86
```

5.3.4 If the preferred parameters are met, it is not necessary to continue the Scan Linearity adjustment. If you are experienced at this adjustment and wish to set the Sum of Deltas and Distance to first edge to nominal, you may. If the preferred parameters are not met, proceed to 5.3.5.

5.3.5 If the allowable parameters are met, proceed to 5.3.12. If the allowable parameters are not met, proceed to 5.3.6.

5.3.6 If the allowable parameters are not met, the beam may be out of position. To check the position of the beam, press the "p" key. A properly positioned beam will result in the following plot.

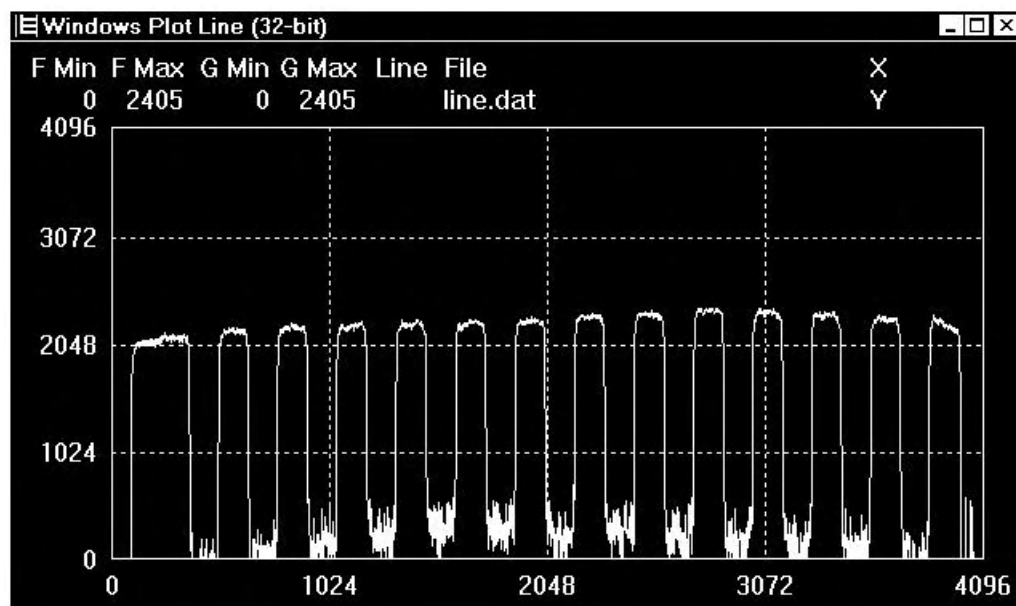

LUMISCAN ACR-2000 READER SERVICE MANUAL - SECTION 5.0 SERVICE ADJUSTMENTS

5.3.7 A properly positioned beam will show all 14 bars with a slight gap on either side. Position the beam properly using the following chart. (*Note: The plot window does not update in real time to show beam position changes. To see the results of an adjustment attempt, it is necessary to close the plot window and press the “p” key again.*)

<u>Adjustment</u>	<u>Directions</u>
Make bars wider / Show fewer bars	Turn R59 Galvo Span Clockwise
Make bars narrower / Show more bars	Turn R59 Galvo Span Counter Clockwise
Move bars to the left	Turn R58 Galvo Offset Clockwise
Move bars to the right	Turn R58 Galvo Offset Counter Clockwise

5.3.8 If, after the beam has been properly positioned, the allowable parameters are met, proceed to 5.4.12.

5.3.9 Use R59 to adjust the Sum of Deltas to nominal.

5.3.10 Use R58 to adjust the Distance to first edge to nominal.

5.3.11 If the allowable parameters are not met, proceed to 5.4.19.

5.3.12 Use R45 and R47 on the Galvo Driver PCA to adjust CAL+ and CAL- to be as low as possible.

5.3.13 Use R59 to adjust the Sum of Deltas to nominal.

5.3.14 Use R58 to adjust the Distance to first edge to nominal.

5.3.15 Use R45 and R47 on the Galvo Driver PCA to adjust CAL+ and CAL- to be as low as possible.

5.3.16 Use R59 to adjust the Sum of Deltas to nominal.

5.3.17 Use R58 to adjust the Distance to first edge to nominal.

5.3.18 **If the preferred parameters are met, the Scan Linearity Adjustment is completed.** Press “q” to quit the program. If the allowable parameters are met, it is left to the discretion of the Service Engineer whether or not to try for the preferred parameters. Due to component aging it is sometimes not possible to meet the preferred parameters. If the allowable parameters are not met, proceed to 5.3.19.

5.3.19 It is necessary at this point to perform **Preliminary Scan Adjustment Method A** or **Preliminary Scan Adjustment Method B**. The purpose of this adjustment is to get the Scan Linearity close, so that when the LNADJDT program is attempted again later, the parameters will be closer to nominal.

5.3.20 Preliminary Scan Adjustment Method A

5.3.20.1 Using an ohmmeter, adjust the following potentiometers to the values listed in the chart. For orientation, observe the PCA's so that the PCB writing is from left to right.

<u>Galvo PCA Ohmmeter Connection</u>	<u>Potentiometer</u>	<u>Value</u>
Top pin of TP1 to left side of R25	R98	240 Ohms
Top of R42 to bottom pin of any test point	R47	2.6K Ohms
Top of R40 to bottom pin of any test point	R111	550 Ohms
Left side of R34 to top of R41	R45	26K Ohms
Top of R26 to bottom of R27	R23	500 Ohms

<u>DACQ PCA Ohmmeter Connection</u>	<u>Potentiometer</u>	<u>Value</u>
Right side of R81 to left side of R79	R58	14K Ohms

5.3.20.2 The room lights should be dim and the unit covered to minimize stray light.

5.3.20.3 Place the 14" Linearity Adjust Pattern (P/N 0070-966) in the input slot with the vertical lines facing the unit and the widest red bar towards the abort button.

5.3.20.4 From the "tools" directory, enter LNADJDT /D at the command prompt. Enter the Serial Number of the reader. Press <Enter> to continue. When prompted for Lines to Skip, press <Enter>. When prompted for Black / White Threshold, enter 1200.

5.3.20.5 Use R59 to adjust the Sum of Deltas to nominal.

5.3.20.6 Proceed to 5.3.10.

5.3.21 Preliminary Scan Adjustment Method B

5.3.21.1 Run DDT, Option 10.

5.3.21.2 While observing the laser sweep, adjust **Galvo Span** and **Galvo Offset** so that the ends of the laser sweep extend **1.5 +/- 0.5** inches past the light Collection Chamber opening on the left side and **2.5 +/- 0.5** inches past the light Collection Chamber opening on the right side.

5.3.21.3 Connect oscilloscope trigger sync. channel to **TP8 ("SOS")** on the **DACQ PCA**. Trigger on -Slope and set sweep to 1 ms/div. Connect **channel 1** to **TP7 (Galvo Feedback)** on the **Galvo PCA**.

5.3.21.4 On **CH1** a downward ramp will be displayed. The shorter upward ramp is the retrace. Use **only R45** and **R47** make the downward slope to be as straight as possible. This is done by maximizing the peak to peak voltage without allowing **any** right facing curvature of the downward slope. Increasing the peak to peak too much with **R45** will cause right facing curvature near the middle of the downward slope. Increasing the peak to peak too much with **R47** will cause right facing curvature near the top of the downward slope.

LUMISCAN ACR-2000 READER SERVICE MANUAL - SECTION 5.0 SERVICE ADJUSTMENTS

5.3.21.5 Visually observe the laser sweep. If the laser sweep extends **1.5 +/- 0.5** inches past the light Collection Chamber opening on the left side and **2.5 +/- 0.5** inches past the light Collection Chamber opening on the right side, then proceed to 5.3.21.6. Otherwise, go back to step 5.3.21.2.

5.3.21.6 The room lights should be dim and the unit covered to minimize stray light.

5.3.21.7 Place the 14" Linearity Adjust Pattern (P/N 0070-966) in the input slot with the vertical lines facing the unit and the widest red bar towards the abort button.

5.3.21.8 From the "tools" directory, enter LNADJDT /D at the command prompt. Enter the Serial Number of the reader. Press <Enter> to continue. When prompted for Lines to Skip, press <Enter>. When prompted for Black / White Threshold, enter 1200.

5.3.21.9 Use R59 to adjust the Sum of Deltas to nominal.

5.3.21.10 Use R58 to adjust the Distance to first edge to nominal.

5.3.21.11 Proceed to 5.3.10.

5.4 PMT Sub System

This section provides the method of adjusting the System for alignment or after replacement of the DACQ PCA, PMT tubes, PMT preamp or Ref Amp.

NOTE

Allow the **LUMISCAN** to warm up for at least 30 minutes prior to making any adjustments.

CAUTION

When making these adjustments, be aware that the Photomultiplier tube is EXTREMELY sensitive to light. When you remove the cover, use a photographic dark cloth to prevent ambient light from damaging the tube or effecting your density adjustments.

5.4.1 PMT Preamp Offset Adjustment

1. Disable the **PMT high voltage**. This is most conveniently done by disconnecting the **AUX I/O** cable on top of the DACQ PCA..
2. Set the DVM for the mV range. Measure at **TP9** on the **DACQ PCA**. If the voltage is **0mV +/- 0.1 mV**, go to **5.4.3**. Otherwise, proceed to step 3.
3. Remove the Front Enclosure from the digitizer.

LUMISCAN ACR-2000 READER SERVICE MANUAL - SECTION 5.0 SERVICE ADJUSTMENTS

4. Connect the DVM to **TP1** of the **PMT Preamp PCA**, with the black (-) lead on the pin toward the bottom.
5. Adjust **R8** on the **PMT Preamp PCA** to obtain a voltage of **+0.0 millivolts, ± 0.1 mv.**
6. Replace the Front Enclosure.
7. Disconnect the DVM and re-enable the **PMT High Voltage**.

5.4.2 PMT Output Voltage Preliminary Check

1. Dim the room lights, cover the unit with a dark cloth.
2. Run **DDT/10** and enter a "p". The display should look as follows:

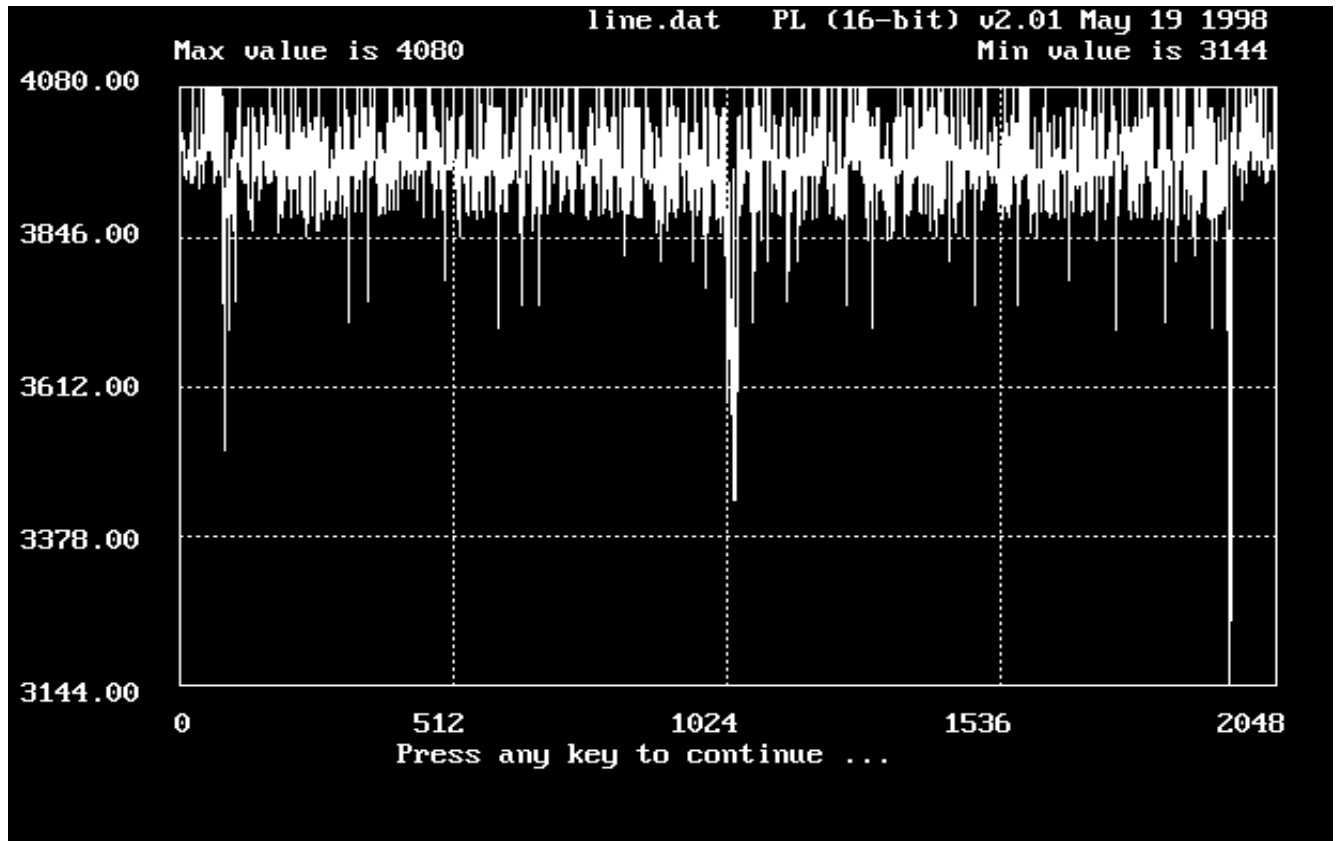

5.4.3 PMT Output Voltage Adjustment and Reference Blue LED Adjustment

The system must be adjusted so that the signal from a plate exposed at a standard X-ray dosage will give a consistent count level. This depends on the plate used, the laser power, the PMT sensitivity, and the alignment of the DACQ board. This is done by an indirect means: First a plate is exposed to a standard x-ray dose and the PMT high voltage is adjusted so as to give approximately "600" counts during scanning. Thereafter the automatic AGC circuit will act to maintain the overall sensitivity constant, based on the blue reference LED.

Place a well erased 14 x 17" image plate into a cassette. Expose with a dose of 8 mAs at 85 kVp, 71" SID. If a 1mm thick copper plate is available, position the copper plate over the x-ray emitter. This will provide a more uniform exposure. **Verify with a high resolution x-ray dose meter that the dosage is 8 mR +/- 0.05 mR.** Be sure the shutters are opened sufficiently to provide full exposure to the entire image plate. Expose the image plate with nothing on top of it.

1. Be sure that the room is darkened . Cover the unit with a dark cloth to block stray light from entering.
2. Remove the exposed image plate from the cassette and place into the feed slot.
3. Ensure a Cltxxxxx.dat is loaded for the system.
4. Run **DDT/16**. Then run **DDT/20**. Press "**m**" to start the transport motor. When prompted select **980** to set the scanning motor speed. This will transport the image plate at a speed sufficient to produce signal.
5. When the image plate reaches the slot the counts should drop from above 3600 to much lower values.
6. Adjust **R140** on the **DACQ** board so that the reported counts are **600 ±20**.

NOTE

You will have about 50 seconds to accomplish this. If you cannot finish in this time you must erase the image plate and repeat the procedure. When done and the image plate falls through, erase the image plate.

6. **R140** is now adjusted and should not be changed again.
7. Run **DDT/20**. The counts should be greater than "3600", indicating no signal. Hit "**b**" (to turn the blue LED on) and observe the counts drop.
8. Adjust **R1** on the **Ref Blue LED/Screen Present** board as necessary to get the peak signal counts to reach **1071 ±10**. Once the desired count range is achieved hit the spacebar to exit mode 20

Note

This now provides a reference signal that is used by the AGC function to maintain PMT sensitivity. Once the adjustment is made the reference LED should require no further adjustment.

LUMISCAN ACR-2000 READER SERVICE MANUAL - SECTION 5.0 SERVICE ADJUSTMENTS

5.4.4 PMT Output Voltage Balancing

1. Place a well erased 14 x 17" image plate into a cassette. Expose with a dose of 4 mAs at 85 kVp, 71" SID. If a 1mm thick copper plate is available, position the copper plate over the x-ray emitter. This will provide a more uniform exposure. **Verify with a high resolution x-ray dose meter that the dosage is 4 mR +/- 0.05 mR.** Be sure the shutters are opened sufficiently to provide full exposure to the entire image plate. Expose the image plate with nothing on top of it.
2. Turn the **ACR-2000** Reader off.
3. Remove the front and rear enclosures. Install the cheater keys for Laser power.
4. Remove the top cover of each PMT tower.
5. Minimize ambient light as much as possible and cover the system well with a dark cloth.
6. Apply power to the **ACR-2000 Reader**.
7. Remove the exposed plate from the cassette and place into the feed slot.
8. Connect oscilloscope trigger sync. channel to the top pin of **TP8 ("SOS")** on the **DACQ PCA**. Trigger on -Slope and set sweep to 1 ms/div. Connect **channel 1** to the top pin of **TP9** on the **DACQ PCA**.
9. Navigate to the "**tools**" directory. Run **DDT**. Select option **16**.
10. Choose option **20**. Observe data scrolling up the screen.
11. Press "**m**" to start the transport motor. When prompted enter **1956** to set the motor speed.
12. Observe the two peaks in the waveform. The left peak is the left PMT as you are facing the Reader. The right peak is the right PMT. Find the PMT with the lowest amplitude.
13. Using the potentiometer on top of the PMT, adjust the lower amplitude PMT to match the amplitude of the other PMT. If the lower gain tube cannot match the amplitude of the higher PMT, both PMT's must be replaced as a set.
14. Turn the ACR-2000 Reader off.
15. Remove the Laser cheater keys.
16. Replace the PMT tower covers.
17. Replace the front and rear enclosures.

18. It is now necessary to make a new CAL Table. To do this proceed to **5.4.5 Calibration Table Generation**.

5.4.5 Calibration Table Generation

5.4.5.1 Using NT Driver Disk prior to version 2.00.

1. Place a well erased 14 x 17" image plate into a cassette. Expose with a dose of 4 mAs at 85 kVp, 71" SID. If a 1mm thick copper plate is available, position the copper plate over the x-ray emitter. This will provide a more uniform exposure. **Verify with a high resolution x-ray dose meter that the dosage is 4 mR +/- 0.05 mR.** Be sure the shutters are opened sufficiently to provide full exposure to the entire image plate. Expose the image plate with nothing on top of it.

2. While in the "TOOLS" directory, scan a full width plate with a uniform field (exposed plate) using special /NOEDGE and /DS:3 switches.

```
“...TOOLS>SCANFILE /NOEDGE /DS:3”
```

This scans at full width scan mode 3 which bypasses the CAL table.

3. While in the "TOOLS" directory, run MKCAL.

```
“...TOOLS>MKCAL LSMT.IMG CALXXXXX.DAT -F 2 -N 1000 -Z 160”
```

Copy the CAL table file into the WINNT\SYSTEM32\DRIVERS directory.

Use the LSMT Control panel to select the CAL table filename.

4. Restart the computer.

5.4.5.2 Using NT Driver Disk version 2.00 or later or DOS/95/98 version 3.60 or later.

1. Place a well erased 14 x 17" image plate into a cassette. Expose with a dose of 4 mAs at 85 kVp, 71" SID. If a 1mm thick copper plate is available, position the copper plate over the x-ray emitter. This will provide a more uniform exposure. **Verify with a high resolution x-ray dose meter that the dosage is 4 mR +/- 0.05 mR.** Be sure the shutters are opened sufficiently to provide full exposure to the entire image plate. Expose the image plate with nothing on top of it.

2. From the "tools" directory, run “...TOOLS>MKCALTBL <Serial Number>”. The program will scan the plate and automatically install the new CAL Table.

3. Restart the computer.

5.4.5.3 View Plot of the Calibration Table.

1. Go to the command prompt.
2. From the “tools” directory, use the **PL.EXE** command to plot WINNT\SYSTEM32\DRIVERS\CALXXXXX.DAT where XXXXX is the serial number of the ACR Reader. If necessary, hit the “a” key to auto scale the plot.
3. The Calibration Table plot should appear as follows.

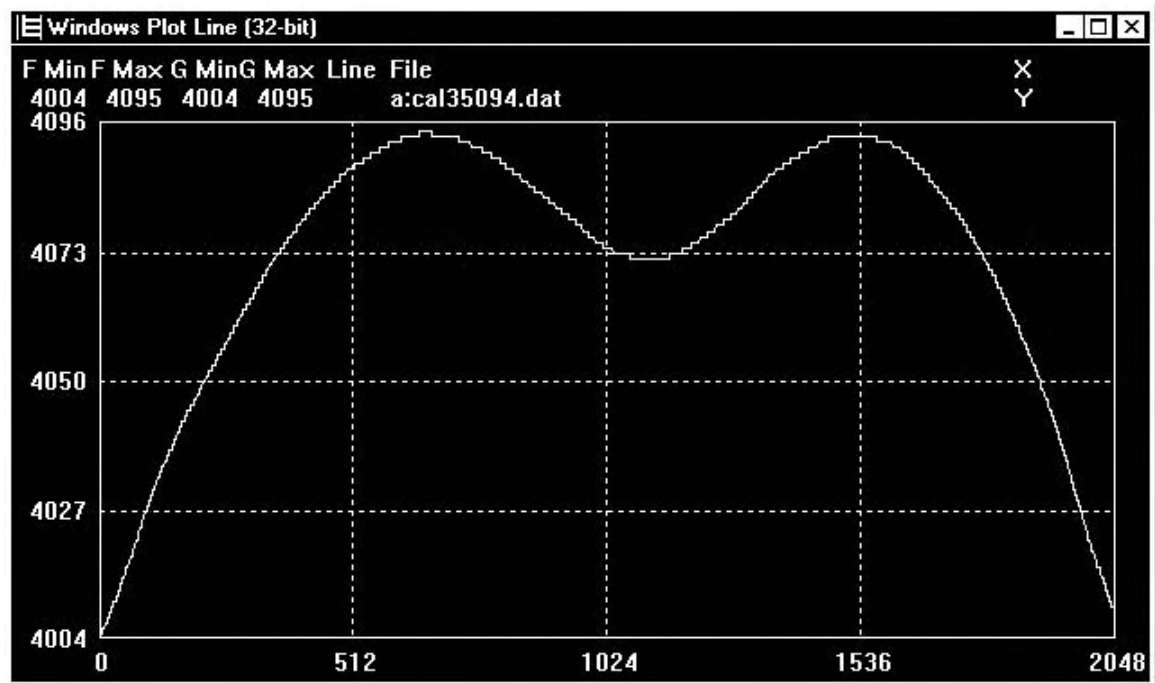

This page intentionally left blank

6.0 PERIODIC MAINTENANCE

System Maintenance is classified in four categories, Daily Maintenance, Routine Maintenance, Periodic Cleaning and Periodic Gain Check. Daily Maintenance and Routine Maintenance are normally performed by the system operator and Periodic Cleaning and Periodic Gain Check are performed by a trained service engineer.

6.1 Daily Maintenance

6.1.1 Clean input guide and output tray with anti-static guard spray daily.

6.1.2 Cover unit at night with lint free cloth or ESD safe plastic sheet.

6.1.3 Clean the storage phosphor screens every day, or every 10 scans.

The physical process by which storage phosphor screens produce CR images does not change over time. The lifetime of the screens, however, is dependent on how they are handled and maintained. Careful handling and proper cleaning of the screens and cassettes will extend their usable lifetime.

Screens should be cleaned after every ten uses. For very high volume facilities, this will mean cleaning the screens at least once, if not twice, a day. Even in low volume facilities, screens must be cleaned once a week. Because they accumulate natural radiation, all screens should be erased once a week.

Clean the screens with a lint-free cloth (for example, KayPees towels). Paper towels, tissue, gauze, or towels should not be used to clean the screens because they leave lint and fibers behind.

Ethyl alcohol, in particular anhydrous denatured ethanol, is recommended for screen cleaning. Apply a generous amount directly to the phosphorous side of the screen and wipe softly and evenly. Also clean the rear side.

Make sure the screen is dry before reloading it into the cassette (allow at least 10 minutes for the solvents to evaporate). It is best to clean the screens at the end of the day so that they will be ready to use the next morning.

Ethyl alcohol and lint-free towels are available from Daigger (www.daigger.com or 800-621-7193). Specially denatured anhydrous ethyl alcohol can be purchased in 500 mL (cat # CX1226A) or 4L (cat # CX1226B) quantities. KayPees disposable paper towels come in cases of 500 (cat #CX5661).

Screens should not be left in the eraser for extended periods of time. Once the screen is erased, it should be removed from the eraser.

6.1.4 Clean area around the system daily. Check for dust.

6.2 Routine Maintenance

Maintenance Periods:

24 times every 12 months.

6.2.1 Cleaning Covers

The outside covers of the **ACR-2000 READER** should be cleaned with a mild soap or detergent. Do not spray cleaner directly on the covers. Spray the soap or detergent on a soft, clean cloth, then wipe down the covers.

6.2.2 Every other week, clean the insides of all the cassettes with a lint-free cloth to remove dust and dirt.

6.3 Periodic Cleaning

Maintenance Periods:

4 times every 12 months.

WARNING

IT IS IMPORTANT THAT THE LUMISCAN COVERS REMAIN ON THE SYSTEM AT ALL TIMES. THE COVERS SHOULD ONLY BE REMOVED FOR SERVICE, AND THEN IMMEDIATELY REPLACED. THIS WILL MINIMIZE DUST ENTRY.

WARNING

THIS EQUIPMENT EMPLOYS A LASER. LASER RADIATION MAY BE PRESENT IF THE LUMISCAN ACR-2000 READER IS OPERATED WITHOUT COVERS. AVOID LASER BEAM. DIRECT EYE EXPOSURE TO LASER LIGHT MUST BE AVOIDED

CAUTION

BE SURE TO USE PROPER ESD PRACTICE WHEN TOUCHING THE ACR-2000 READER WITH THE COVERS OFF

CAUTION

DO NOT CLEAN THE GALVO MIRROR OR ROOF MIRROR EXCEPT AS A LAST RESORT AND UNDER THE GUIDANCE OF LUMISYS TECHNICAL SUPPORT

NOTE

DUST OR FIBERS IN THE LASER BEAM PATH MAY AFFECT THE RADIOGRAPHIC IMAGE

- 6.3.1 The main objective is to remove particles that may cause vertical lines in images.
- 6.3.2 Digitize an image for comparison with performance after cleaning.
- 6.3.3 Remove the ACR-2000 READER main cover.
- 6.3.4 Remove the fan filter and clean with warm soapy water.
- 6.3.5 Remove the front cover.
- 6.3.6 Vacuum the interior.
- 6.3.7 Manually turn the rollers and clean the rollers with a damp lint free cloth.
- 6.3.8 Clean the laser entry slot of the light collection chamber with lens tissue and a compressed gas duster.
- 6.3.9 Remove the front pressure plate.
- 6.3.10 Remove any lint that may be adhering to the laser output slot. Use lens tissue and a compressed gas duster.
- 6.3.11 Replace front pressure plate and covers.
- 6.3.12 Digitize an image and check for vertical lines. If lines remain, look for lint and particles corresponding to the position of the remaining lines. A flashlight can be used to illuminate lint particles.

6.4 PMT Output Voltage Adjustment and Reference Blue LED Adjustment

1. Perform the **PMT Output Voltage Adjustment and Reference Blue LED Adjustment** as specified in **Chapter 5** section **5.4.3**.

7.0 DIAGNOSTICS

If a system failure occurs, it is necessary to diagnose the cause before effecting the repair.

This section describes the diagnostic tools and techniques used to isolate various types of system failures.

7.1 Troubleshooting

The cause of some failures may be obvious. In these cases, the Service Engineer may proceed directly to the repair.

Before beginning an investigation, it is a good practice to record as much information about the current state of the system as possible. This information may include, but is not limited to, symptoms, conditions under which symptoms exist, voltages, settings, cleanliness, and visual state.

Normal generic troubleshooting techniques apply. With knowledge of the system, isolate the failure to a particular subsystem. With knowledge of the subsystem, trace the symptom back to its cause.

In many cases, failures are caused by lack of periodic maintenance and cleaning. If a system is known to be behind schedule for its maintenance and cleaning at the time of the failure, it is a good practice to clean and recalibrate the system before extensive troubleshooting. In many cases this solves the problem or provides clues as to the cause.

7.2 Symptoms and Their Causes

Here are some of the most common symptoms of system failures and some known causes.

7.2.1 Vertical Lines In Images

If the lines are random within an image but repeatable in each successive image, there is likely lint blocking the beam near the focal point of the **Laser**. This is the most common cause of vertical lines. The procedure for removing lint is in **Chapter 6**.

If cleaning doesn't remove the lines, moving the beam up or down a couple of millimeters sometimes helps. This is done with the 45 degree roof mirror

7.2.2 Horizontal Lines and Banding In Images

The most common cause of horizontal lines is excessive ambient light. Verify that the light present in the room is 2EV maximum.

In many cases, too much ambient light will create dark horizontal bands at the top and the bottom of images.

LUMISCAN ACR-2000 SERVICE MANUAL – SECTION 7.0 DIAGNOSTICS

7.2.3 System Will Not Detect Phosphor Screens

If the screen moves into the system several inches and stops without backing up, the screen is not being detected. The most common cause of this failure is a failed **Laser Module**.

To determine if the Laser is functioning, remove the main enclosure, turn the Laser on and visually determine if the Laser is functioning. Ensure that the interior of the scanner is not exposed to ambient light, as this might damage the **Photo-Multiplier Tubes**. Also, enable the Laser interlock with one of the interlock keys clamped to the side of the frame. To activate the Laser, run the **DDT.EXE** program, which is located in the Lumisys “tools” directory. Then, select option **20**, which turns the Laser on and makes it scan back and forth across the light collection chamber. If the Laser is not emitting light, the Laser Module needs to be replaced. If the Laser is emitting light, it is possible that it is not emitting enough light.

To check for adequate Laser light, manually push an erased phosphor screen six inches into the rollers. This will ensure that the screen is in the Laser path. Then run the DDT.EXE program from the “tools” directory. Select option 20. Press the “i” key to activate the screen detector. Press the “p” key to plot the detection signal. On most ACR Readers, the screen detector signal will appear as follows.

LUMISCAN ACR-2000 SERVICE MANUAL – SECTION 7.0 DIAGNOSTICS

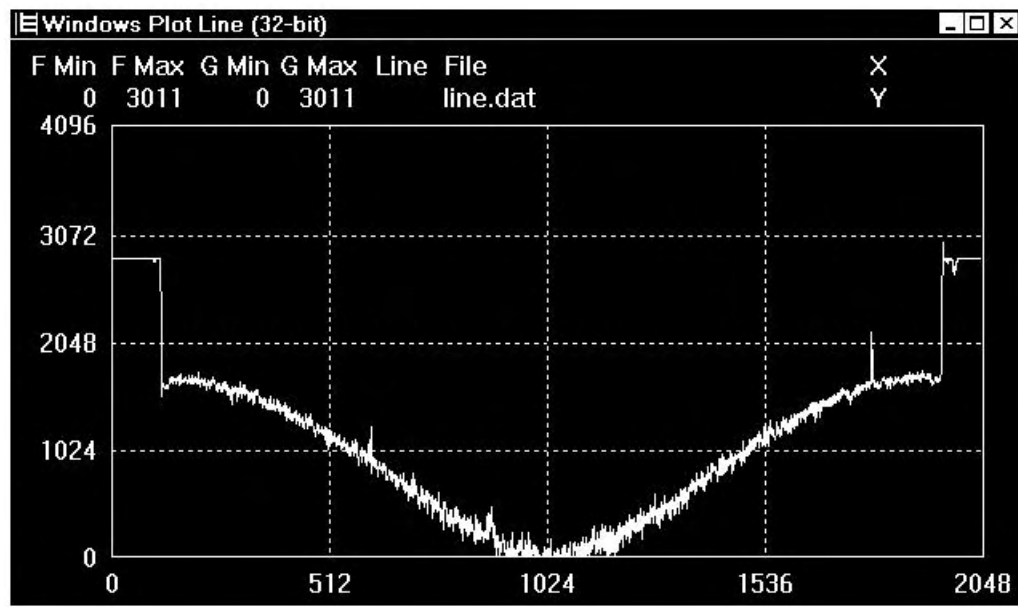

This is an inverted signal with the highest amplitude at the bottom of the plot, which is a value of zero. If the amplitude is not near zero, as an example 500 or 1000, the Laser is not emitting enough light and needs to be replaced.

The screen detector plot for older ACR Readers is three spikes, each with an amplitude of approximately **1600**. ACR Readers with **Data Acquisition PCA** part numbers **0070-735** and below have this older screen detector. If the spike amplitude is significantly below 1600, as an example 500 or 1000, the Laser is not emitting enough light and needs to be replaced.

If there are less than three spikes visible, the Laser may not be aligned with the screen detectors. The procedure to realign the old style screen detectors is in the **Chapter 5** paragraph titled, **Plate Detector Alignment**.

7.2.4 Non Uniformity of Density

Non uniformity of density is where one side of the image is significantly darker or lighter than the other side. The primary cause for this is a failed PMT. To determine which one of the two PMTs has failed, attempt scans with each PMT disconnected from its cable. The PMT that, while disconnected, has no effect on scanned images is the PMT that needs to be replaced. When replacing a PMT, be sure to perform the **PMT Output Voltage Balancing Procedure** and the **Calibration Table Generation Procedure**. Both of these procedures are in **Chapter 5**.

LUMISCAN ACR-2000 SERVICE MANUAL – SECTION 7.0 DIAGNOSTICS

7.2.5 DI-2000 Self Test Failure

If **Autozero** and **AGC** both fail, the PMTs are suspect.

If **Autozero** fails, there may be too much ambient light in the room.

If **AGC** fails, perform the **PMT Output Voltage Adjustment and Reference Blue LED Adjustment** which is in **Chapter 5**.

7.2.6 No Photo-Multiplier Tube Output

Verify that the Laser is emitting light, by using DDT.EXE option 20, with the Laser interlock installed. If the Laser is not emitting light, the Laser Module needs to be replaced.

Attempt to perform the **PMT Output Voltage Adjustment** which is in **Chapter 5**. The initial measurement of the PMT Output Voltage mean data value before the adjustment should normally be between 600 and 1000. If the mean data value is near 4095, the PMTs are probably not getting voltage from the **PMT High Voltage Power Supply**.

CAUTION

THE PMT HIGH VOLTAGE IS SEVERAL HUNDRED VOLTS DIRECT CURRENT

Using a Digital Volt Meter set to DC Volts, check the PMT High Voltage by measuring the voltage from the top pin of **Test Point 2** (voltage) to the bottom pin of **Test Point 1** (reference) on the **PMT Preamp PCA** which is located behind the front cover. The voltage should be above –300VDC. If the voltage is near zero, the **PMT High Voltage Power Supply** is likely to have failed.

If there is voltage at Test Point 2, check the cable between the PMT Preamp PCA and the Data Acquisition PCA for bent pins.

LUMISCAN ACR-2000 SERVICE MANUAL – SECTION 7.0 DIAGNOSTICS

7.2.7 No Galvanometer Movement

The most common cause of no Galvanometer movement is failed drive circuitry on the Data Acquisition PCA.

Remove the AUX/IO connector from the Data Acquisition PCA to disable the PMT High Voltage Power Supply. This will protect the PMTs from ambient light during the investigation.

Manually roll a 14X17 inch plate into to the beam slot to serve as a backdrop for the laser light.

Run DDT.EXE option 20 to activate the Galvanometer. Install the Laser interlock key.

If the beam is sweeping back and forth across the plate, the Galvanometer is functioning properly.

Disconnect the Galvanometer drive signal cable at the Data Acquisition PCA connector labeled “GALVO”. Disconnect the other end of the same cable from the **Galvo Driver PCA**. Use an oscilloscope to monitor the Galvo drive signal at the top pin of **Test Point 6** on the DACQ PCA. If there isn't a drive signal present, the DACQ PCA is malfunctioning or is adjusted to zero Galvo span.

If there is a drive signal present, connect the drive signal cable to the DACQ PCA while leaving the other end disconnected. If the drive signal is lost, the cable needs to be replaced.

If the drive signal is still present, connect the drive signal cable to the Galvo Driver PCA. If the drive signal is lost, the Galvo Driver PCA needs to be replaced.

If the drive signal is still present, verify with a DVM that the Galvo Driver PCA is receiving its input voltage of +15VDC and –15VDC. This can be measured at **L1** and **L2** on the Galvo Driver PCA.

If the Galvo Driver PCA is receiving its proper input voltage, attach the oscilloscope to the junction of R66 and R67 on the Galvo Driver PCA. If there is a drive signal, detach and reattach the Galvanometer. If the Galvanometer still doesn't function, it needs to be replaced. If there is no drive signal to the Galvanometer, the Galvo Driver PCA needs to be replaced.

LUMISCAN ACR-2000 SERVICE MANUAL – SECTION 7.0 DIAGNOSTICS

7.3 Diagnostic Programs

This document outlines use of some of the diagnostic programs. The Diagnostics programs are used **exclusively** for diagnostics, testing, aligning and troubleshooting of the **ACR-2000 READER**. They are intended to be used by service engineers for diagnostic and test purposes only.

The following is a list of the current diagnostics that support the **ACR-2000 READER** product.

Here is a list of some of those diagnostics

C:\LSDT32\TOOLS- LSDT tools, programs

LNADJDT.EXE - Linearity adjustment

DDT.EXE - Diagnostic used to exercise the Driver & Scanner

PL.EXE - Plots a line of data or a file to display

SCANFILE.EXE - Example image acquisition application

LUMISCAN ACR-2000 SERVICE MANUAL – SECTION 7.0 DIAGNOSTICS

7.3.1 DDT.EXE

Enter > DDT

Enter one of the specified numbers (1 through 22, or 'q') at the command prompt.

DDT VX.X		<date>	<time>
1. Scan File			
2. Read Data			
3. Read Status			
4. Load LUT			
5. Read LUT			
6. Clear CAL Table			
7. Plot CAL Table			
8. Reset Scan			
9. Test CAL/LUT			
10. Display A/D			
21. System Info			
q. Exit Program			
command ->__			
11. Change Parameters			
12. Start Motor			
13. Diagnostic Scan			
14. Test Image Memory			
15. Stop Scan & Eject			
16. Reset Hardware			
17. Set Averaging Mode			
18. Set Laser Mode			
19. Pulse Screen Feed			
20. Display Noise Value			
22. Set CR/Scan5 Modes			

Enter > **1** (Scan Screen) - insert screen to be scanned. Screen will be scanned, image will be stored in DCB memory.

You can also test the SCAN ABORT button when scanning a screen. Press the SCAN ABORT button any time during a scan. Pressing SCAN ABORT has the following effect: Press SCAN ABORT (1st time) - stops screen

Press SCAN ABORT (2nd time) - reverses screen

Press SCAN ABORT (3rd time) - stops screen

Press SCAN ABORT (4th time) - forwards screen

Press SCAN ABORT (5th time) - stops screen

Enter > **2 Read Screen** - this reads the image stored in DCB memory (by a previous SCAN SCREEN) into a file. The default file is LSDT.IMG.

Enter > **3 Read Status** - the current status of the scanner driver is displayed

Enter > **4** (Load LUT) - download to the DACQ a specific LUT.

Enter > **5** (Read LUT) - read from the DACQ a specified LUT. The LUT you read should reflect the LUT you most recently downloaded to the DACQ.

Enter > **6** (Clear CAL table) - clears the CAL table on the DACQ to 4095.

LUMISCAN ACR-2000 SERVICE MANUAL – SECTION 7.0 DIAGNOSTICS

Enter > **7** (Plot CAL table) - plots the DACQ CAL table. A normal CAL table will look somewhat like an irregular “M” shape. A screen must be scanned before a Cal curve is generated.

Enter > **8** (Reset Scan) - This resets the scanner driver.

Enter > **9** (Test CAL & LUT Memory) - This writes a specified pattern to the LUT

Enter > **10** (Display A/D Value) - This writes a specified pattern to the LUT memory. Resources are either FAILED or PASSED. See 7-10.

L = Laser on/off 1=dim 2=full on 0=off

E =

B = Turn the Blue on and off

V =

I =

Enter > **11** (Change Parameters) - You can change any of the following DACQ timers. Numbers given are example calculated values.

1. Scan Motor Clock = 25000
2. Screen Motor Clock = 1956
3. Pixel Clock = 122
4. Delay to First Pixel = 1484
5. Pixels Per Line = 2048
6. Lines Per Screen = 5
7. Variable Scan Mode = VARIABLE
8. Bits Per Pixel = 12 Bits
9. Pixel Byte Order = LSB/MSB
10. Reset to Defaults

Select Parameters ->

Enter > **12** (Start Motor) - You can start the motor in the specified direction.

Enter > **13** (Diagnostic Scan) - perform a specified diagnostic scan from the sub-menu.

Enter > **14** (Test Image Memory) - the specified pattern is echoed to the DCB memory. PASSED or FAILED are the expected responses.

Enter > **15** (Stop Scan & Eject) - Stops the scan in progress and ejects the screen.

Enter > **16** (Reset HARDWARE) - This resets the scanner driver(doesn't reload the driver), the DACQ & DCB hardware. Also reloads the CLUT.

Enter > **17** (quit) Set Averaging Mode) - Unused for current system.

Enter > **18** (Set laser Mode) - Turns LEDs on and off.

Enter > **19** (Pulse Screen Feed) - Loads a screen from the screen loader.

LUMISCAN ACR-2000 SERVICE MANUAL – SECTION 7.0 DIAGNOSTICS

Enter > **20** (Display Noise Value)-

M =

B =

Enter > **21** (System Infor)- Detailed system information

Enter > **22** (Set CR/Scan5 Mode) -

Other commands you may enter (not specified by the **DDT menu**);

Enter> **o** (oscope)- plots the scanline to the screen.

Enter > **s** (screen) - dump contents of screen to a file

Enter > **pl** (plotcal) - Plots a data file to the screen, ie: results.dat.

The following sections are guidelines for troubleshooting sections of the scanner using **DDT**.

Autozero Check

The room lights should be dim and the unit covered to minimize stray light. Run **DDT** option **13/5**. Observe the reported results and verify that the voltage reported for Autozero is within the limits ± 1 volts(the closer to 0 the better). If not check the offset adjustment of the PMT Preamp, which should be 0 mv with P14 disconnected from the DACQ.

Verify AGC Function

Run **DDT** option **13/5** and verify that the reported AGC voltage is within ± 1.0 volts, indicating little or no AGC compensation required. Unplug the blue LED cable from J1 of the Ref LED/Scrn Pres board and rerun option 13/5. Verify that the AGC voltage is more positive, indicating that it is adding high voltage to compensate for signal loss. Reconnect the blue LED to J1 and repeat 13/5. Verify that the voltage decreases.

Test DACQ Calibration and Lookup Table Access

Run **DDT**. From the menu choose **9. Test CAL and LUT Memory**. From the submenu choose 1. Up Ramp Test. The test was successful if the screen prints "PASSED" and returns to the main menu, otherwise it will print the first 64 errors. Repeat test 9 for the following submenu choices:

2. Down Ramp Test
3. Walking 1 Test
4. Walking 0 Test

Test Cal Table Clear Function

From the **DDT** menu choose **6. Clear Calibration Table**. There will be no output - the screen just redispays the menu. Choose **7. Plot Cal Table**. A graph should appear on the screen displaying 1024 values of 4096 (Max Value = 4096, Min value = 4094). Press any key to return to menu.

LUMISCAN ACR-2000 SERVICE MANUAL – SECTION 7.0 DIAGNOSTICS

Test Lookup Table Load and Readback Function

From the DDT menu choose **4. Load LUT**. A list of choices will be displayed. Select 1 = 0:4095 12 Bit Lut. Select 15. Choose **5: Read LUT**. Select 15. All 4096 values (in hex) will scroll up the screen in lines of 16. Observe the last column as it scrolls: Verify that the last digit is always "F" while the first digit of the last column increments from "0" through "F". The last few lines will remain on the screen. Verify that the last line is:

```
FF0 FF1 FF2 FF3 FF4 FF5 FF6 FF7 FF8 FF9 FFA FFB FFC FFD FFE FFF
```

followed by a return to the menu.

Test Digital-only Data Path

From the DDT menu choose **11. Change Parameters** and then **6. Lines Per Image** and enter 1024. Return to the main menu and select **13. Diagnostic Scan**. From the submenu choose **7- Diagnostic Pattern**. In response to the query "Do overlapped writes to a LSDT.IMG [default=y]", just press Enter. Wait for the return to the main menu. This causes the DACQ under test to generate a test pattern consisting of 256 lines of data values 0 through 1023, followed by 256 lines of data values 1024 through 2047, and so on.

From the DDT menu enter the following command line: **H12**, the following line will appear:

```
hist12 0 lsdt.img 1024 1024 0 2048 | more
```

This executes the program HIST12, which counts the number of occurrences of each data value in the range 0 through 4095, and displays the results on the screen which you can pause by hitting <ctrl>S, then any key to resume. Examine each screenful and verify that every reported count is 256. Hit any key (such as the spacebar) to display the next screenful; repeat for the entire file and until the DDT menu returns.

Verify that the last line displays the following message:

```
"Total Occurrences = 1048576". (which is 1024 pixel X 1024 lines).
```

When complete the screen returns to the main menu.

Repeat this entire test, except in the submenu choose **6- Flat Field Pattern**. When the results of HIST12 are displayed, verify that the reported count for every value is 0 except for 1285, which should have a count of 1048576.

Choose **11: Change Parameters**. Select **9- LSB/MSB**. This will reverse the order to MSB first. Hit <enter> to return to main menu. Repeat the diagnostic scan with mode **7- Diagnostic Pattern**. Repeat the HIST12 analysis. This time, since the byte ordering has been reversed the results reported by HIST12 should be as follows: As the numbers scroll past you should see 16 groups of 16 consecutive bins with 4096 counts each, and all other bins with 0 counts. The groups will be located at bins 0 through 15, 256 through 271, 512 through 527, and ending with 3840 through 3855.

LUMISCAN ACR-2000 SERVICE MANUAL – SECTION 7.0 DIAGNOSTICS

7.3.2 SCANFILE

Scanfile using the following parameters:

Pixels per line : 2048
Pixel depth : 12 bits/pixel
Pixel format : LSB
LUT format : Normal
Filename : lsdt.img

The command line for "SCANFILE" has the following format:

SCANFILE /PPL:/PD:/PF:/LUT:/F:/TIF /AM /PMT /PPI /NOEDGE /EDGE

Options available are:

PIXELS PER LINE: Default is 1024
/PPL:x Set PIXELS PER LINE to x

PIXELS PER INCH
/PPI: pixels per inch

PIXEL DEPTH: Default is 12 bits
/PD:12 Set PIXEL DEPTH to 12 bits/pixel
/PD:8 Set PIXEL DEPTH to 8 bits/pixel

PIXEL FORMAT: Default is LSB first
/PF:LSB Set PIXEL FORMAT to LSB first
/PF:MSB Set PIXEL FORMAT to MSB first

LOOK UP TABLE: Default is Normal
/LUT:N Set LUT to normal - 0.0 Optical Density = 0
/LUT:I Set LUT to inverted - 0.0 Optical Density = 4095

OUTPUT FILE: Default is lsdt.img
/F:filename Set filename

Tiff File Format:
/TIF Set to create TIFF image file

Averaging Method
/AM: X or XY

LUMISCAN ACR-2000 SERVICE MANUAL – SECTION 7.0 DIAGNOSTICS

PMT Register

/PMT: 0 through 255

Edges

/NOEDGE

/EDGE

If the user would like to scan a screen into a file called image5.img using defaults, from the MS-DOS prompt type:

"scanfile /f:image5.img"

This command will digitize a screen using 12 bits, 1024 pixels in width, create a header and put a file named image5.img in the current directory.

LUMISCAN ACR-2000 SERVICE MANUAL – SECTION 7.0 DIAGNOSTICS

This page intentionally left blank

8.0 INTRODUCTION

This section discusses the various components of the **LUMISCAN ACR-2000 READER** digitizer that can be replaced in the field. It also details the removal of the **LUMISCAN ACR-2000 READER** covers, along with component removal and replacement. Components which can be replaced in the field are called field replaceable units, or **FRUs**. These will be discussed later in this section.

8.1 Removing the LUMISCAN ACR-2000 READER Covers

This section reviews the removal of the **LUMISCAN ACR-2000 READER** outer panels. There are two individual panels on the **LUMISCAN ACR-2000 READER**, and for the purposes of this manual they are labeled Front cover and Main enclosure.

8.1.1 Main Enclosure Removal

The Main enclosure is the rear cover of the system. To remove the Main enclosure perform the following:

1. Remove the system interface cable and the A/C power cable.
2. Remove the 3 phillips screws from the rear of the system.
3. Remove the 3 phillips screws from each side of the system. Total of 6.
4. Remove the main enclosure by sliding it to the rear of the system and off.

8.1.2 Front Cover Removal

1. Remove the 4 phillips screws (2 on each side) from the front cover.
2. Remove the three screws attaching the front of the enclosure to the interior alignment bar.
3. Disconnect the two cables coming from the front going to the DACQ PCA.
4. Remove the front cover.

8.2 Field Replaceable Units (FRUs)

Overview

This section discusses the sub-systems and components in the **ACR-2000 READER** that can be replaced in the field. These are called **Field Replaceable Units** or **FRUs**. Certain **FRUs** may require some adjustments when they are replaced. The following chart details all of the **FRUs** in the **READER** that have adjustment requirements when they are replaced. All adjustments are contained in **Section 5** of the Service Manual.

LUMISCAN ACR-2000 SERVICE MANUAL - SECTION 8.0 REPLACEMENT PARTS

Sub-Assembly	FRU	ADJUSTMENT
Optics	PMT PreAmp PCA	PMT
	PMT Tubes	PMT
	Laser	Optical, PMT
	Galvo PCA	Linearity
	Galvo Motor	Linearity
Electronics	DACQ PCA	PMT, Linearity
Pinch Rollers	DC Drive Motor	-None
Power Supply	15VDC Supply	15VDC Supply
	-1Kv PMT Supply	PMT

8.3 Optics Module

Inside the system, there are 5 components that can be replaced in the field. These are:

1. PMT Tubes
2. PMT PreAmp PCA
3. Laser
4. Galvo PCA
5. Galvo Motor

8.3.1 PMT SUB-SYSTEM

The PMT sub-system (the PMT Tubes and PMT PreAmpPCA) can be replaced by following the procedure outline below

PMT PRE-AMP PCA REMOVAL

The following tools will be necessary to remove the PMT system:

1. Flat blade screwdriver
2. Philips #2 screwdriver

The PMT PreAmp PCA is located at the top of the Collection Cylinder (Figure 8-2). Remove the Main enclosure and Front cover to gain access to the PMT Preamp.

CAUTION: There are several wires coming from the tube's connector going to J6 on the PMT PCA. These wires are fragile and could break if mishandled.

1. Unplug J14 on the DACQ.
2. Remove the PMT PreAmp assembly cover by removing the 2 pan head screws.
3. Remove the 3 cables going to the PMT Pre-amp.
4. Remove the 4 mounting screws from the PMT PreAmp PCA and remove the PCA.
5. Replace and secure PCA, reconnect cables and replace PCA cover.

PMT REMOVAL AND REPLACEMENT

When replacing a failed PMT it is required procedure to replace both tubes with a matched pair. The gain characteristics of unmatched tubes can be such that they cannot be balanced.

Newer models may have a different configuration than described below where there is a single PMT tower containing both tubes. In this case there will be foam “doughnuts” providing pressure and holding the tubes in place. In this case simply removing the top cover and foam doughnuts from the PMT tower will allow you to remove the tubes. Replacement is self-evident. Also note that in this newer configuration the blue filters are not held to the tubes by photographic tape.

Ensure that power to the machine is off.

1. Remove the covers and the cable from the PMT sockets. Remove the PMT connection cable from the tubes and the preamp.
2. Remove the four 9/64” screws securing each PMT Tower. Lift the towers off the collection cylinder.

LUMISCAN ACR-2000 SERVICE MANUAL - SECTION 8.0 REPLACEMENT PARTS

3. Loosen the two 7/64" clamp screws recessed in the back side of the tower. Remove the PMT face first (from the bottom), being careful not to get fingerprints on the blue filter.
4. Remove the blue filter attached to the PMT.
5. Attach the blue filter to the replacement PMT with black photographic tape. Overlap the top of the filter with about 1/8 inch of tape. Fold the tape edge over the filter to secure the filter to the PMT. It's important to get the tape as flat as possible on the filter to avoid light leaks which will cause vertical artifacts in an image.
6. Insert the PMT into the tower and place the tower face down on a clean surface such as a table top with a soft cloth. By setting the assembly on a table it is a simple matter to get the tube flush with the bottom of the tower.
7. Note that the tubes are keyed where they connect with the cable. Position the tubes so that they fit the cable's sockets. Facing the machine from the front, the left tube should be keyed toward "12:00" while the right tube key is at "3:00". Gently and evenly tighten the PMT clamps with the two clamp screws. Do not over tighten or damage to the tube may occur.
8. Perform the PMT Offset Voltage adjust, PMT balancing, High Voltage adjust and blue LED adjust (Refer to section 5.4 of this manual).

8.3.2 LASER DIODE MODULE

LASER DIODE DRIVER ASSEMBLY REMOVAL AND REPLACEMENT

WARNING

USE PROPER ESD PRACTICE WHEN TOUCHING LASER OR SCANNER

EXTREME CAUTION

1. The laser assembly produces 18 to 25 mW of power. Care must be taken to avoid looking directly at the beam.
2. The Laser Diode output is transmitted to the lens through a fiber optic cable. The end of this cable has a protective cap that is removed when the cable is screwed into the lens assembly. Great care must be taken so that the end of the cable does not come into contact with anything, i.e., fingers, metal, etc., or damage will occur.

LUMISCAN ACR-2000 SERVICE MANUAL - SECTION 8.0 REPLACEMENT PARTS

3. Special attention must be given to adding jumpers on JP2 and JP3 on the Laser Diode Driver board when removing the laser assembly, and removing these jumpers after the replacement assembly is installed. If these steps are not followed carefully, damage can occur to the laser diode.

REMOVING LASER DIODE MODULE

1. Turn off the system and remove the main enclosure.
2. Remove the Galvo PCA/bracket assembly from the bulkhead leaving the galvo motor connected. Set the PCA/bracket assembly inside the reader away from the laser assembly.
 - 2a. The bracket is secured to the bulkhead by two phillips head screws and a 5/16" hex head nut.
3. Install jumpers across JP2 and JP3 on the Laser Diode Driver PCA. Those jumpers are shipped from the factory hanging off one of the pins of each jumper.
4. Disconnect the interlock cable from the interlock switch.
5. Disconnect the DC power cable going to J1 on the Laser Diode Driver PCA.
6. Observe the ferrule securing the tip of the fiber optic cable to the F/C mount in the lens barrel. With your fingers, gently unscrew the ferrule then very gently slide the cable the lens assembly. Be extremely careful not to contaminate or damage the tip of the cable. Immediately place the protective cap over the end.
7. Remove the four 7/64" hex screws securing the Laser Diode Driver Assembly to the bulkhead.
8. Remove the Assembly and place in the protective anti-static package the replacement arrived in. Return the assembly to Lumisys.

REPLACING LASER DIODE MODULE

1. Mount the Laser Diode Assembly to the bulkhead using the four screws.
2. Remove the protective cap from the end of the fiber optic cable. Be extremely careful to not touch the exposed end of the cable with anything or damage will occur. Note the key at the cable end and place properly to the lens assembly. Secure by turning the locking ferrule finger-tight.
3. Connect the power cable to J1 of the Laser Diode Driver PCA and remove the protective jumpers from JP2 and JP3. Place the jumpers on one pin of JP2 and JP3 in case the assembly has to be removed in the future.

LUMISCAN ACR-2000 SERVICE MANUAL - SECTION 8.0 REPLACEMENT PARTS

4. Connect the interlock cable to the interlock switch.
5. Reinstall the Galvo PCA.

Refer to Section 5 “Final High Voltage Adjustment and Reference LED Adjustment” to set the high voltage and Blue LED.

Occasionally after replacing the laser module the spot size is adversely affected resulting in poor image resolution. The fiber optic tip not being inserted correctly into the connector on the lens barrel assembly often causes this. If there is a resolution problem it is always best to confirm that the connection between the fiber optic cable tip is keyed correctly. If you are confident that the fiber optic tip is placed correctly in the connector and resolution is still poor then it may be necessary to re-focus the beam.

FOCUSING THE LASER

Focusing the laser beam is **never** done as part of a standard PM. The beam spot is set at the factory and will not change without a preceding event such as changing the laser itself. Gain, laser power and cleanliness could all effect resolution quality. **Never** re-focus the laser without consulting a member of the Lumisys Technical Support Staff.

An oscilloscope, a very dim light environment, a non shedding cloth (preferably an opaque photographic shroud) to drape over the machine and a red Lumisys QA pattern are required for this procedure.

1. Remove the main enclosure, place a cheater key in the interlock, dim the lights and cover the reader with the opaque cloth.
2. Connect channel one of the scope to SIG (TP1) and sync off SOS (TP8).
3. From the tools directory Run ddt option 20.
4. On the lens barrel assembly the two set screws that are nearest the fiber cable end of the assembly secure the F/C connector in the barrel assembly preventing it from moving.
5. Loosen these two set screws with a 1/16” hex-head wrench such that they are still putting a small pressure on the F/C connector. This pressure will help with control during the minute changes you will be making during the focusing procedure. Furthermore if the set screws are too loose focus will probably be effected when you retighten them.
6. Place the red Lumisys QA test pattern in the reader such that a block set of three line pair patterns are in the beam path. Notice that there are three distinct, side by side traces representing the three different line pair densities with three different amplitudes. The tightest line pair pattern will have the smallest amplitude.

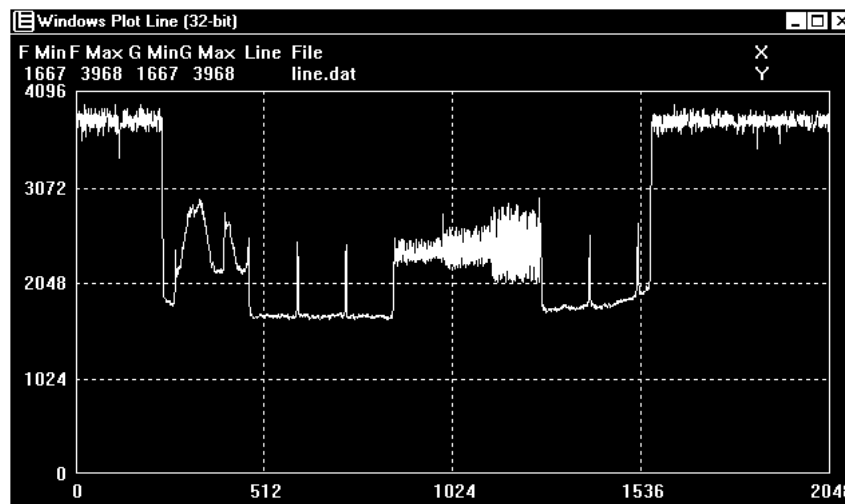

Triple block line pair pattern trace (at center).

7. While gripping the locking ferrule (which you tightened when you put the fiber optic cable tip) gently move the connector until you see amplitude changes in the line pair traces. You want to achieve the best possible amplitude of the smallest line pair block. The actual amplitudes will vary some from test pattern to test pattern. The vertical setting on the scope should be as sensitive as possible.
8. Once you are confident that you have the best possible amplitude tighten the two set screws firmly but not too tight. Make sure the ferrule is still tight on the connector.
9. Scan the red Lumisys QA Test Pattern and view the image. The lines of tightest line pair pattern should be distinct, though some aliasing will be evident.

8.3.3 GALVANOMETER REMOVAL

Turn power off

1. Remove the Main cover.
2. Remove the Galvo access cover.
 - 2a. The Galvo Access Panel is on the rear bulkhead secured by six 5/16" nuts
3. Remove the Galvo driver board/bracket assembly from bulkhead.
 - 3a. The bracket is secured to the bulkhead by two phillips head screws with washers and one 5/16" hex head nut.
 - 3b. Clip tie-wrap securing the Galvo Motor cable to bracket

LUMISCAN ACR-2000 SERVICE MANUAL - SECTION 8.0 REPLACEMENT PARTS

4. Unplug the Galvo Motor cable from the driver board.
5. Remove the four 7/64" hex-head screws holding the Galvo motor from the Galvo mount assembly. Be very careful not to scratch the replicating mirror.
6. Remove the Galvo motor and retain the 4 plastic shoulder washers and plastic isolation gasket.
7. Remove the replicating mirror from the galvanometer shaft.

7a. The mirror is secured by a .050" nylon tipped set screw. It is not necessary to remove this set screw entirely. Just loosen it enough to easily remove the mirror. Leave the set screw in place.

7b. Be very careful to not touch the mirrored surface when removing the mirror from the galvanometer shaft. It is best to use a soft lens cleaning paper or cloth and grip the sides of the mirror with your fingers and slowly slide the mirror off the galvanometer shaft.

REPLACEMENT

Re-install the new Galvo motor in the reverse order except do not re-place the mirror until the other components are in place. Re-installing the tie-wrap and isolation gasket are important steps. That galvo cable, if not tied up, could obstruct the laser exiting the galvo tower.

Replacing the Replicating Mirror and Locating Mechanical Center.

1. After the Galvanometer is securely mounted on the galvo tower slide the replicating mirror back onto the galvanometer shaft.
2. Place a Post-It note or similar object, centered, over the entrance slot of the collection chamber.
3. With a pen or pencil mark the Post-It with a dot on the horizontal center of the collection chamber. This can be done by eye using landmarks such as the PMT towers. Bisect the area between the PMT towers to find the center of the collection chamber. Do not use the tape on either side of the collection chamber as a reference.
4. Ensure that J14 on the DACQ and J3 on the Galvo PCA are unplugged. This will disallow high voltage to the tubes and power to the galvo respectively. Ensure that the interlocks are actuated.
5. Turn on power.

LUMISCAN ACR-2000 SERVICE MANUAL - SECTION 8.0 REPLACEMENT PARTS

6. Without touching the mirrored surface, using the mark on the Post-it note as a reference, carefully rotate the replicating mirror until the beam spot is centered with respect to the collection chamber. Don't worry if the spot is not perfectly aligned along the y-axis (vertically bisecting the slot itself) and slightly above or below the mark.
7. Tighten the set screw on the mirror.
8. Replace the access cover. Ensure that all relevant fasteners are secure and connectors plugged in.

Realign the Galvo motor per **Section 5.3** of this manual.

8.4 DRIVE MOTOR/ENCODER ASSEMBLY

Removal

Notice and remember the orientation of the encoder at the end of the drive motor.

Cut the tie-wraps securing the encoder cable and motor cables.

Disconnect the cables from the Film Enc and Film Mtr connectors on the DACQ and feed them through the hole in the bulkhead. It may be necessary to remove the grommet from the hole in the bulkhead.

Remove the drive belt.

Loosen the set screw that secures the pulley to the drive shaft.

Remove the pulley from the drive shaft. You now have access to the screws securing the motor assembly to the adjusting plate.

Remove the three or four (depending on the rev) screws securing the motor assembly to the adjusting plate.

Remove the drive motor/encoder.

REPLACEMENT

The Drive Motor/Encoder Assembly should be replaced in the reverse order that it was removed, taking care to replace the grommet and securing the cables with tie wraps.

ACR-2000 SERVICE MANUAL - SECTION 9 SCHEMATICS

SCHEMATICS AND DRAWINGS

PART NUMBER	DESCRIPTION
0070-578	TREE, PRODUCT, LS135
0071-317	DIAG, AC & DC WIRING, LS135
0071-318	DIAG, SYSTEM INTCON & PWR DISTRIBUTION, LS135
0070-679	SCH, REF LED, SCR N PRES1, V2
0070-235	SCH, DCB3, V1, LSDT
0068-855	SCHEMATIC, GALVO DRIVER V5, LSDT
0071-552	SCH, BLUE LED/ISFILM, LS135
0070-254	SCH, PMT PREAMP, V1, LSDT
0071-997	SCH, DATA ACQUISITION BOARD 4, V1, LS135B

APPENDIX A: LUMISCAN ACR-2000 Reader JUMPER AND SWITCH SETTINGS

Identifying your Data Control Board (DCB)

There are three versions of the DCB in existence. The newer DCB3 has slightly different switch settings than the DCB1 or DCB2. Here's how to identify them:

Ver	Size	IRQ	Address DIP Switch	Memory Address	Base I/O Address	Memory Size
DCB1	Big (13" long)	JP1	S1 (6 bits)	S1-1 thru S1-5	S1-6	N / A
DCB2	Med (9" long)	JP2	S1 (6 bits)	S1-1 thru S1-5	S1-6	N / A
DCB3	Small (6" long)	JP2	S1 (8 bits)	S1-1 thru S1-5	S1-6 thru S1-7	S1-8

Changing IRQ Level

The **LUMISCAN 50 / 75 / 85** is factory configured to use IRQ level 5. The IRQ level may be changed by setting a jumper on the Data Control Board (JP1 or JP2, see table above). To change the setting, remove the jumper from its current position and move it to the desired level.

JPx (see above table)
0 0 0 0 0
|
0 0 0 0 0
3 4 5 6 7
IRQ

If the IRQ is changed from level 5 you **MUST** inform the driver when it is loaded. This is accomplished by using a switch. The switch is a forward slash (/) such as used with MS-DOS commands. The format is /Ix, where x is the IRQ level. For example, to install the driver using IRQ 6 from the MS-DOS prompt you would enter **"*LSDTVxxx /I6*"**.

Changing Window Address

The **LUMISCAN 50 / 75 / 85** is factory configured to use a 32-Kbyte window starting at address D0000 and ending at D7FFF. The upper 5 bits of the address are set with the 6-position ADDRESS SELECT SWITCH (S1-1 through S1-5) on the DATA CONTROL BOARD (DCB), switch position S1-6 is used to set the BASE I/O ADDRESS.

NOTE: If the DCB is changed from its default address of **D0000**, you must add the **/Mxxxx** switch to the driver load command to provide the driver the new 4-digit "SEGMENT ADDRESS". The command would like this:

C:\LSDT\TOOLS\LSDTVxx /ME000

The following table shows how to set this switch to achieve the desired address.

<u>ADDRESS</u>	<u>S1-1</u>	<u>S1-2</u>	<u>S1-3</u>	<u>S1-4</u>	<u>S1-5</u>	<u>COMMENTS</u>
A0000	ON	ON	OFF	OFF	OFF	Normally used for VGA Cards
A8000	OFF	ON	OFF	ON	OFF	Normally used for VGA Cards
B0000	ON	OFF	OFF	ON	OFF	Normally used for VGA Cards
B8000	OFF	OFF	OFF	ON	OFF	Normally used for VGA Cards
C0000	ON	ON	ON	OFF	OFF	Normally used for VGA Cards
C8000	OFF	ON	ON	OFF	OFF	
D0000	ON	OFF	ON	OFF	OFF	Default Setting for DCB
D8000	OFF	OFF	ON	OFF	OFF	
E0000	ON	ON	OFF	OFF	OFF	
E8000	OFF	ON	OFF	OFF	OFF	

NOTE: If the address is changed, care must be taken to select an address range which is not being used by another device. The most significant bit of the address is controlled by switch position S15. Lumisys supplies a utility program, **FINDMEM**, which can be used to identify potential open address locations in the range A0000-EFFFF. **FINDMEM** has the following output format:

C:\LSDT\TOOLS>FINDMEM

```
A000:0000 --USED-- A000:0000 = 20
A800:0000 --USED-- A800:0000 = 20
B000:0000 --USED-- B000:0000 = 4D
B800:0000 --USED-- B800:0000 = 20
C000:0000 --USED-- C000:0000 = 55
C800:0000 --USED-- C800:0000 = 4D
D000:0000 **FREE**
D800:0000 --USED-- D800:0000 = 5A
E000:0000 --USED-- E000:0000 = B4
E800:0000 --USED-- E800:0000 = 41
```

EMM386.EXE and your CONFIG.SYS

Whichever DCB memory address is used, your CONFIG.SYS should be modified to exclude the DCB Memory Mapped Address range from use by EMM386.EXE. The following line is normally used:

DEVICE=C:\DOS\EMM386.EXE NOEMS X=D000-D7FF

Changing the BASE I/O ADDRESS

Switch S1-6 is used to control the BASE I/O ADDRESS. Either S1-6 or both S1-6 and S1-7 are used, according to the DCB model:

<u>Ver</u>	<u>Base I/O Address</u>
DCB1	S1-6
DCB2	S1-6
DCB3	S1-6 thru S1-7

Placing the switch (or switches) in the factory default position OFF position selects the **FACTORY DEFAULT I/O ADDRESS 100**. Setting the switch (or switches) to the ON position selects I/O ADDRESSES 120, 140 or 160, according to the DCB model. When not in the factory default position, the **/B** switch must be added to the driver load command. For example:

\LSDT\TOOLS\LSDTVxx /B120

How to set this switch to achieve the desired address for a DCB1 or DCB2:

<u>BASE I/O</u>	<u>ADDRESS</u>	<u>S1-6</u>
100	OFF	OFF
120	ON	ON

How to set this switch to achieve the desired address for a DCB3:

<u>BASE I/O</u>	<u>ADDRESS</u>	<u>S1-6</u>	<u>S1-7</u>
100	OFF	OFF	OFF
120	ON	OFF	OFF
140	OFF	ON	ON
160	ON	ON	ON

Changing the MEMORY SIZE

For DCB3s, switch S1-8 is used to specify the size of the installed memory:

MEMORY
SIZE S1-8

4 MBytes OFF
16 MBytes ON