

Table of Contents

1. Introduction.....	7-3
2. The Design Problem Generally	7-3
3. Power-Handling Ability	7-4
4. Output Power, P_o , Versus Apparent Power, P_p , Capability	7-5
5. Transformers with Multiple Outputs	7-8
6. Regulation.....	7-10
7. Relationship, K_g , to Power Transformer Regulation Capability.....	7-12
8. Relationship, A_p , to Transformer Power Handling Capability	7-13
9. Different Cores, Same Area Product.....	7-13
10. 250 Watt Isolation Transformer Design, Using the Core Geometry, K_g , Approach	7-15
11. 38 Watt 100kHz Transformer Design, Using the Core Geometry, K_g , Approach.....	7-20

Introduction

The conversion process in power electronics requires the use of transformers and components that are frequently the heaviest and bulkiest item in the conversion circuit. They also have a significant effect upon the overall performance and efficiency of the system. Accordingly, the design of such transformers has an important influence on the overall system weight, power conversion efficiency and cost. Because of the interdependence and interaction of parameters, judicious trade-offs are necessary to achieve design optimization.

The Design Problem Generally

The designer is faced with a set of constraints that must be observed in the design on any transformer. One of these constraints is the output power, P_o , (operating voltage multiplied by maximum current demand). The secondary winding must be capable of delivering to the load within specified regulation limits. Another constraint relates to the minimum efficiency of operation, which is dependent upon the maximum power loss that can be allowed in the transformer. Still another defines the maximum permissible temperature rise for the transformer when it is used in a specified temperature environment.

One of the basic steps in transformer design is the selection of proper core material. Magnetic materials used to design low and high frequency transformers are shown in Table 7-1. Each one of these materials has its own optimum point in the cost, size, frequency and efficiency spectrum. The designer should be aware of the cost difference between silicon-iron, nickel-iron, amorphous and ferrite materials. Other constraints relate to the volume occupied by the transformer and, particularly in aerospace applications, the weight, since weight minimization is an important goal in today's electronics. Finally, cost effectiveness is always an important consideration.

Depending upon the application, certain ones of these constraints will dominate. Parameters affecting others may then be a trade-off, as necessary, to achieve the most desirable design. It is not possible to optimize all parameters in a single design because of their interaction and interdependence. For example, if volume and weight are of greater significance, reductions in both can often be affected, by operating the transformer at a higher frequency, but at a penalty in efficiency. When, the frequency cannot be increased, reduction in weight and volume may still be possible by selecting a more efficient core material, but, at the penalty of increased cost. Thus, judicious trade-offs must be affected to achieve the design goals.

Transformer designers have used various approaches in arriving at suitable designs. For example, in many cases, a rule of thumb is used for dealing with current density. Typically, an assumption is made that a good working level is 200 amps-per-cm² (1000 circular mils-per-ampere). This will work in many instances, but

Table 7-1. Magnetic Materials

Magnetic Material Properties				
Material Name	Trade Name Composition	Initial Permeability μ_i	Flux Density Teslas B_s	Typical Operating Frequency
Silicon	3-97 SiFe	1500	1.5-1.8	50-2k
Orthonol	50-50 NiFe	2000	1.42-1.58	50-2k
Permalloy	80-20 NiFe	25000	0.66-0.82	1k-25k
Amorphous	2605SC	1500	1.5-1.6	250k
Amorphous	2714A	20,000	0.5-6.5	250k
Amorphous	Nanocrystalline	30,000	1.0-1.2	250k
Ferrite	MnZn	0.75-15k	0.3-0.5	10k-2M
Ferrite	NiZn	0.20-1.5k	0.3-0.4	0.2M-100M

the wire size needed to meet this requirement may produce a heavier and bulkier transformer than desired or required. The information presented in this chapter makes it possible to avoid the use of this assumption and other rules of thumb, and to develop a more economical design with greater accuracy.

Power-Handling Ability

For years manufacturers have assigned numeric codes to their cores; these codes represent the power-handling ability. This method assigns to each core a number that is the product of its window area, W_a , and core cross-section area, A_c , and is called the area product, A_p .

These numbers are used by core suppliers to summarize dimensional and electrical properties in their catalogs. They are available for laminations, C-cores, pot cores, powder cores, ferrite toroids, and toroidal tape-wound cores.

The regulation and power-handling ability of a core is related to the core geometry, K_g . Every core has its own inherent, K_g . The core geometry is relatively new, and magnetic core manufacturers do not list this coefficient.

Because of their significance, the area product, A_p , and core geometry, K_g , are treated extensively in this book. A great deal of other information is also presented for the convenience of the designer. Much of the material is in tabular form to assist the designer in making trade-offs, best-suited for his particular application in a minimum amount of time.

These relationships can now be used as new tools to simplify and standardize the process of transformer design. They make it possible to design transformers of lighter weight and smaller volume, or to optimize efficiency, without going through a cut-and-try, design procedure. While developed especially for aerospace applications, the information has wider utility, and can be used for the design of non-aerospace, as well.

Output Power, P_o , Versus Apparent Power, P_t , Capability

Output power, P_o , is of the greatest interest to the user. To the transformer designer, the apparent power, P_t , which is associated with the geometry of the transformer, is of greater importance. Assume, for the sake of simplicity, that the core of an isolation transformer has only two windings in the window area, a primary and a secondary. Also, assume that the window area, W_a , is divided up in proportion to the power-handling capability of the windings, using equal current density. The primary winding handles, P_{in} , and the secondary handles, P_o , to the load. Since the power transformer has to be designed to accommodate the primary, P_{in} , and, P_o , then,

By definition:

$$P_t = P_{in} + P_o, \quad [\text{watts}]$$

$$P_{in} = \frac{P_o}{\eta}, \quad [\text{watts}] \quad [7-1]$$

The primary turns can be expressed using Faraday's Law:

$$N_p = \frac{V_p (10^4)}{A_c B_{ac} f K_f}, \quad [\text{turns}] \quad [7-2]$$

The winding area of a transformer is fully utilized when:

$$K_u W_a = N_p A_{wp} + N_s A_{ws} \quad [7-3]$$

By definition the wire area is:

$$A_w = \frac{I}{J}, \quad [\text{cm}^2] \quad [7-4]$$

Rearranging the Equation shows:

$$K_u W_a = N_p \left(\frac{I_p}{J} \right) + N_s \left(\frac{I_s}{J} \right) \quad [7-5]$$

Now, substitute in Faraday's Equation:

$$K_u W_a = \frac{V_p (10^4)}{A_c B_{ac} f K_f} \left(\frac{I_p}{J} \right) + \frac{V_s (10^4)}{A_c B_{ac} f K_f} \left(\frac{I_s}{J} \right) \quad [7-6]$$

Rearranging shows:

$$W_a A_c = \frac{[(V_p I_p) + (V_s I_s)] (10^4)}{B_{ac} f J K_f K_u}, \quad [\text{cm}^4] \quad [7-7]$$

The output power, P_o , is:

$$P_o = V_s I_s, \quad [\text{watts}] \quad [7-8]$$

The input power, P_{in} , is:

$$P_{in} = V_p I_p, \quad [\text{watts}] \quad [7-9]$$

Then:

$$P_t = P_{in} + P_o, \quad [\text{watts}] \quad [7-10]$$

Substitute in, P_t :

$$W_a A_c = \frac{P_t (10^4)}{B_{ac} f J K_f K_u}, \quad [\text{cm}^4] \quad [7-11]$$

By definition, A_p , equals:

$$A_p = W_a A_c, \quad [\text{cm}^4] \quad [7-12]$$

Then:

$$A_p = \frac{P_t (10^4)}{B_{ac} f J K_f K_u}, \quad [\text{cm}^4] \quad [7-13]$$

The designer must be concerned with the apparent power, P_t , and power handling capability of the transformer core and windings. P_t may vary by a factor, ranging from 2 to 2.828 times the input power, P_{in} , depending upon the type of circuit in which the transformer is used. If the current in the rectifier transformer becomes interrupted, its effective RMS value changes. Thus, transformer size is not only determined by the load demand, but also, by application, because of the different copper losses incurred, due to the current waveform.

For example, for a load of one watt, compare the power handling capabilities required for each winding, (neglecting transformer and diode losses, so that $P_{in} = P_o$). For the full-wave bridge circuit of Figure 7-1, the full-wave center-tapped secondary circuit of Figure 7-2, and the push-pull, center-tapped full-wave circuit in Figure 7-3, all the windings have the same number of turns, (N).

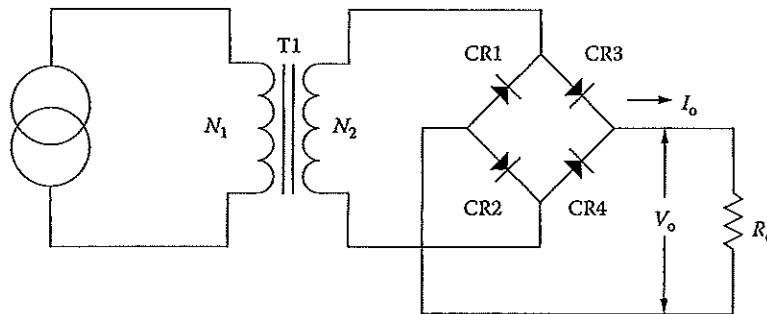

Figure 7-1. Full-Wave Bridge Secondary.

The total apparent power, P_t , for the circuit shown in Figure 7-1 is 2 watts.

This is shown in the following Equation:

$$P_t = P_{in} + P_o, \text{ [watts]} \tag{7-14}$$

$$P_t = 2P_{in}, \text{ [watts]} \tag{7-15}$$

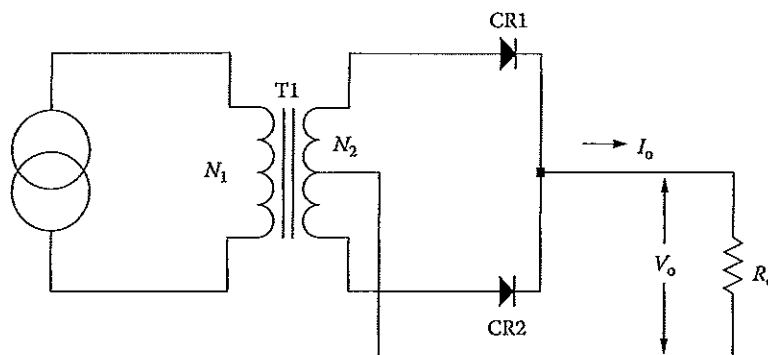

Figure 7-2. Full-Wave, Center-Tapped Secondary.

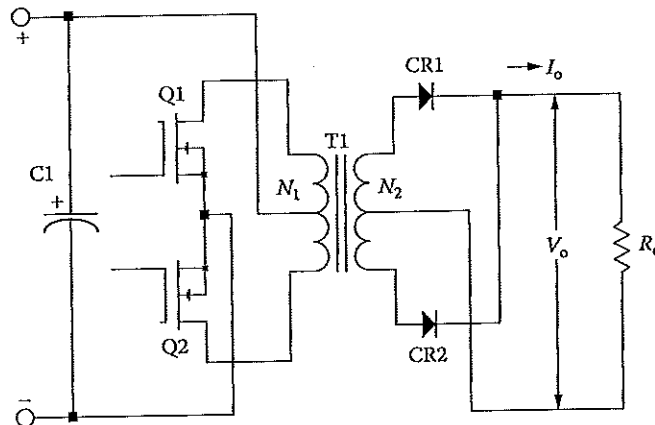

Figure 7-3. Push-Pull Primary, Full-Wave, Center-Tapped Secondary.

The total power, P_t , for the circuit shown in Figure 7-2, increased 20.7%, due to the distorted wave form of the interrupted current flowing in the secondary winding. This is shown in the following Equation:

$$P_t = P_{in} + P_o \sqrt{2}, \quad [\text{watts}] \quad [7-16]$$

$$P_t = P_{in} (1 + \sqrt{2}), \quad [\text{watts}] \quad [7-17]$$

The total power, P_t , for the circuit is shown in Figure 7-3, which is typical of a dc to dc converter. It increases to 2.828 times, P_{in} , because of the interrupted current flowing in both the primary and secondary windings.

$$P_t = P_{in} \sqrt{2} + P_o \sqrt{2}, \quad [\text{watts}] \quad [7-18]$$

$$P_t = 2P_{in} \sqrt{2}, \quad [\text{watts}] \quad [7-19]$$

Transformers with Multiple Outputs

This example shows how the apparent power, P_t , changes with a multiple output transformers.

Output	Circuit
5 V @ 10A	center-tapped $V_d = \text{diode drop} = 1 \text{ V}$
15 V @ 1A	full-wave bridge $V_d = \text{diode drop} = 2 \text{ V}$
Efficiency = 0.95	

The output power seen by the transformer in Figure 7-4 is:

$$\begin{aligned}
 P_{o1} &= (V_{o1} + V_d)(I_{o1}), \text{ [watts]} \\
 P_{o1} &= (5 + 1)(10), \text{ [watts]} \\
 P_{o1} &= 60, \text{ [watts]}
 \end{aligned}
 \tag{7-20}$$

And:

$$\begin{aligned}
 P_{o2} &= (V_{o2} + V_d)(I_{o2}), \text{ [watts]} \\
 P_{o2} &= (15 + 2)(1.0), \text{ [watts]} \\
 P_{o2} &= 17, \text{ [watts]}
 \end{aligned}
 \tag{7-21}$$

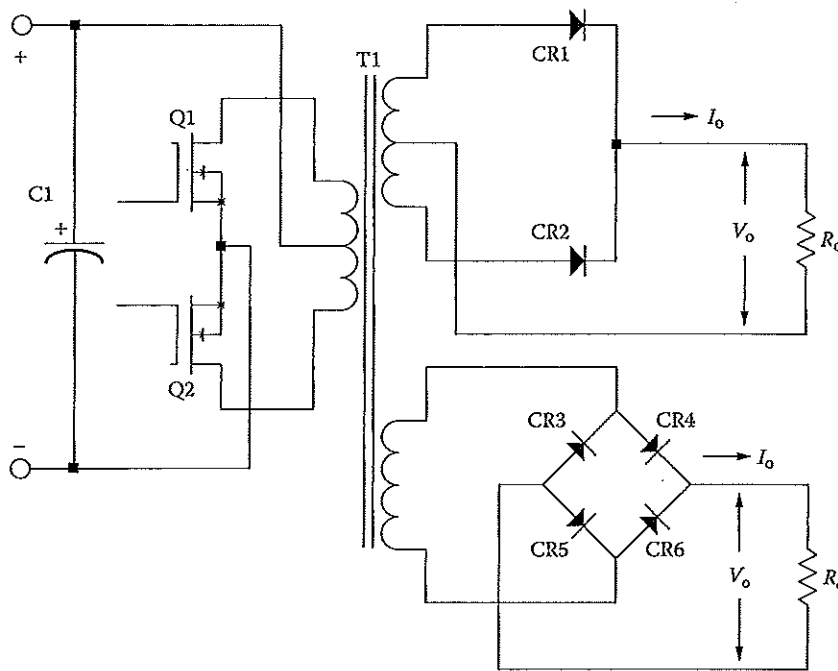

Figure 7-4. Multiple Output Converter.

Because of the different winding configurations, the apparent power, P_v , the transformer outputs will have to be summed to reflect this. When a winding has a center-tap and produces a discontinuous current, then, the power in that winding, be it primary or secondary, has to be multiplied by the factor, U . The factor, U , corrects for the rms current in that winding. If the winding has a center-tap, then the factor, U , is equal to 1.41. If not, the factor, U , is equal to 1.

For an example, summing up the output power of a multiple output transformer, would be:

$$P_{\Sigma} = P_{o1}(U) + P_{o2}(U) + P_n(U) + \dots
 \tag{7-22}$$

Then:

$$\begin{aligned}
 P_{\Sigma} &= P_{o1}(U) + P_{o2}(U), \text{ [watts]} \\
 P_{\Sigma} &= 60(1.41) + 17(1), \text{ [watts]} \\
 P_{\Sigma} &= 101.6, \text{ [watts]}
 \end{aligned}
 \tag{7-23}$$

After the secondary has been totaled, then the primary power can be calculated.

$$\begin{aligned}
 P_{in} &= \frac{P_{o1} + P_{o2}}{\eta}, \text{ [watts]} \\
 P_{in} &= \frac{(60) + (17)}{(0.95)}, \text{ [watts]} \\
 P_{in} &= 81, \text{ [watts]}
 \end{aligned}
 \tag{7-24}$$

Then, the apparent power, P_t , equals:

$$\begin{aligned}
 P_t &= P_{in}(U) + P_{\Sigma}, \text{ [watts]} \\
 P_t &= (81)(1.41) + (101.6), \text{ [watts]} \\
 P_t &= 215.8, \text{ [watts]}
 \end{aligned}
 \tag{7-25}$$

Regulation

The minimum size of a transformer is usually determined either by a temperature rise limit, or by allowable voltage regulation, assuming that size and weight are to be minimized. Figure 7-5 shows a circuit diagram of a transformer with one secondary.

Note that $\alpha = \text{regulation } (\%)$.

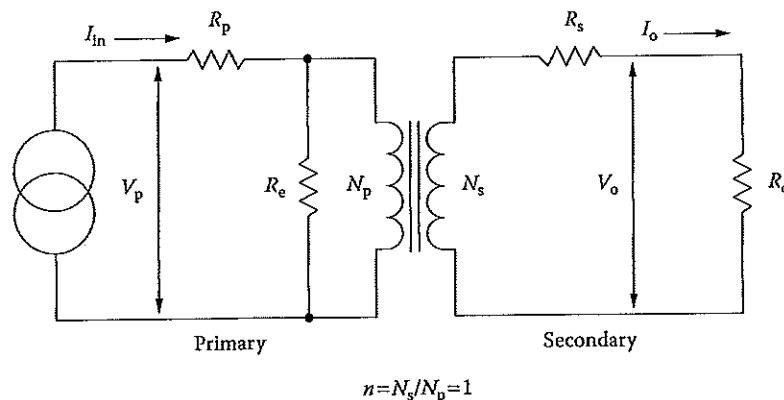

Figure 7-5. Transformer Circuit Diagram.

The assumption is that distributed capacitance in the secondary can be neglected because the frequency and secondary voltage are not excessively high. Also, the winding geometry is designed to limit the leakage inductance to a level, low enough, to be neglected under most operating conditions.

Transformer voltage regulation can now be expressed as:

$$\alpha = \frac{V_o(\text{N.L.}) - V_o(\text{F.L.})}{V_o(\text{F.L.})}(100), \quad [\%] \quad [7-26]$$

In which, $V_o(\text{N.L.})$, is the no load voltage and, $V_o(\text{F.L.})$, is the full load voltage. For the sake of simplicity, assume the transformer in Figure 7-5, is an isolation transformer, with a 1:1 turns ratio, and the core impedance, R_c , is infinite.

If the transformer has a 1:1 turns ratio, and the core impedance is infinite, then:

$$\begin{aligned} I_{in} &= I_o, \quad [\text{amps}] \\ R_p &= R_s, \quad [\text{ohms}] \end{aligned} \quad [7-27]$$

With equal window areas allocated for the primary and secondary windings, and using the same current density, J :

$$\Delta V_p = I_{in} R_p = \Delta V_s = I_o R_s, \quad [\text{volts}] \quad [7-28]$$

Regulation is then:

$$\alpha = \frac{\Delta V_p}{V_p} (100) + \frac{\Delta V_s}{V_s} (100), \quad [\%] \quad [7-29]$$

Multiply the Equation by currents, I :

$$\alpha = \frac{\Delta V_p I_{in}}{V_p I_{in}} (100) + \frac{\Delta V_s I_o}{V_s I_o} (100), \quad [\%] \quad [7-30]$$

Primary copper loss is:

$$P_p = \Delta V_p I_{in}, \quad [\text{watts}] \quad [7-31]$$

Secondary copper loss is:

$$P_s = \Delta V_s I_o, \quad [\text{watts}] \quad [7-32]$$

Total copper loss is:

$$P_{cu} = P_p + P_s, \text{ [watts]} \quad [7-33]$$

Then, the regulation Equation can be rewritten to:

$$\alpha = \frac{P_{cu}}{P_o}(100), \text{ [%]} \quad [7-34]$$

Regulation can be expressed as the power lost in the copper. A transformer, with an output power of 100 watts and a regulation of 2%, will have a 2 watt loss in the copper:

$$P_{cu} = \frac{P_o \alpha}{100}, \text{ [watts]} \quad [7-35]$$

$$P_{cu} = \frac{(100)(2)}{100}, \text{ [watts]} \quad [7-36]$$

$$P_{cu} = 2, \text{ [watts]} \quad [7-37]$$

Relationship, K_g , to Power Transformer Regulation Capability

Although most transformers are designed for a given temperature rise, they can also be designed for a given regulation. The regulation and power-handling ability of a core is related to two constants:

$$\alpha = \frac{P_l}{2K_g K_e}, \text{ [%]} \quad [7-38]$$

$$\alpha = \text{Regulation (\%)} \quad [7-39]$$

The constant, K_g , is determined by the core geometry, which may be related by the following Equations:

$$K_g = \frac{W_a A_c^2 K_u}{MLT}, \text{ [cm}^5\text{]} \quad [7-40]$$

The constant, K_e , is determined by the magnetic and electric operating conditions, which may be related by the following Equation:

$$K_e = 0.145 K_f^2 f^2 B_m^2 (10^{-4}) \quad [7-41]$$

Where:

K_f = waveform coefficient

4.0 square wave

4.44 sine wave

From the above, it can be seen that factors such as flux density, frequency of operation, and the waveform coefficient have an influence on the transformer size.

Relationship, A_p , to Transformer Power Handling Capability

Transformers

According to the newly developed approach, the power handling capability of a core is related to its area product, A_p , by an equation which may be stated as:

$$A_p = \frac{P_i (10^4)}{K_f K_u B_m J f}, \quad [\text{cm}^4] \quad [7-42]$$

Where:

K_f = waveform coefficient

4.0 square wave

4.44 sine wave

From the above, it can be seen that factors, such as flux density, frequency of operation, and the window utilization factor, K_u , define the maximum space which may be occupied by the copper in the window.

Different Cores, Same Area Product

The area product, A_p , of a core is the product of the available window area, W_a , of the core in square centimeters, (cm^2), multiplied by the effective, cross-sectional area, A_c , in square centimeters, (cm^2), which may be stated as:

$$A_p = W_a A_c, \quad [\text{cm}^4] \quad [7-43]$$

Figures 7-6 through Figure 7-9 show, in outline form, three transformer core types that are typical of those shown in the catalogs of suppliers.

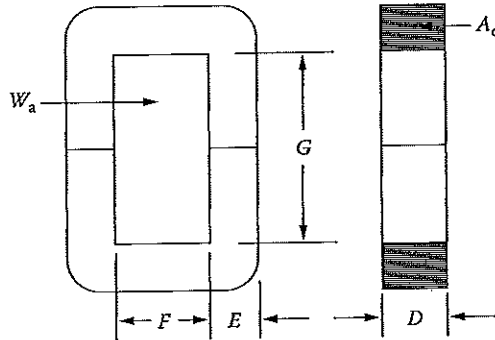

Figure 7-6. Dimensional Outline of a C Core.

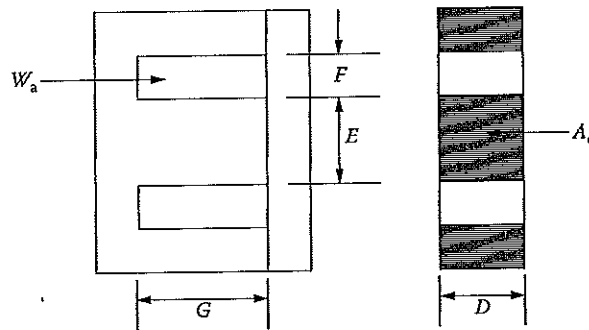

Figure 7-7. Dimensional Outline of a EI Lamination.

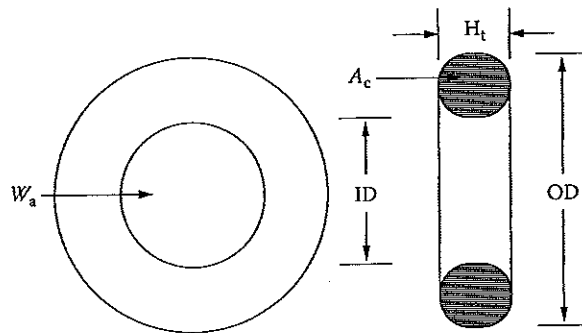

Figure 7-8. Dimensional Outline of a Toroidal Core.

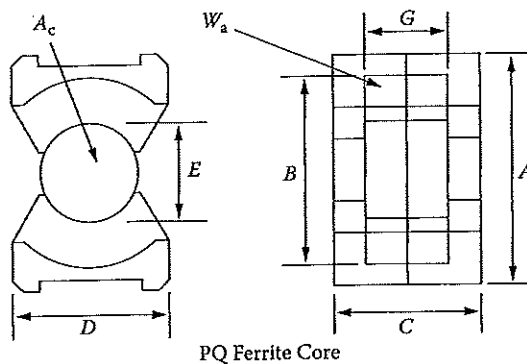

Figure 7-9. Dimensional Outline of a PQ Ferrite Core.

250 Watt Isolation Transformer Design, Using the Core Geometry, K_g , Approach

The following information is the Design specification for a 250 watt isolation transformer, operating at 47 Hz, using the, K_g , core geometry approach. For a typical design example, assume with the following specification:

1. Input voltage, $V_{in} = 115$ volts
2. Output voltage, $V_o = 115$ volts
3. Output current, $I_o = 2.17$ amps
4. Output power, $P_o = 250$ watts
5. Frequency, $f = 47$ Hz
6. Efficiency, $\eta = 95\%$
7. Regulation, $\alpha = 5\%$
8. Operating flux density, $B_{ac} = 1.6$ teslas
9. Core Material = Silicon M6X
10. Window utilization, $K_u = 0.4$
11. Temperature rise goal, $T_r = 30^\circ\text{C}$

Step No. 1: Calculate the transformer apparent power, P_t .

$$P_t = P_o \left(\frac{1}{\eta} + 1 \right), \text{ [watts]}$$

$$P_t = 250 \left(\frac{1}{0.95} + 1 \right), \text{ [watts]}$$

$$P_t = 513, \text{ [watts]}$$

Step No. 2: Calculate the electrical conditions, K_e .

$$K_e = 0.145 (K_f)^2 (f)^2 (B_m)^2 (10^{-4})$$

$$K_f = 4.44, \text{ [sine wave]}$$

$$K_e = 0.145 (4.44)^2 (47)^2 (1.6)^2 (10^{-4})$$

$$K_e = 1.62$$

Step No. 3: Calculate the core geometry, K_g .

$$K_g = \frac{P_t}{2K_e\alpha}, \text{ [cm}^5\text{]}$$

$$K_g = \frac{(513)}{2(1.62)(5)}, \text{ [cm}^5\text{]}$$

$$K_g = 31.7, \text{ [cm}^5\text{]}$$

Step No. 4: Select a lamination from Chapter 3, comparable in core geometry, K_g .

Lamination number = EI-150

Manufacturer = Thomas and Skinner

Magnetic path length, MPL = 22.9 cm

Core weight, W_{fe} = 2.334 kilograms

Copper weight, W_{cu} = 853 grams

Mean length turn, MLT = 22 cm

Iron area, A_c = 13.8 cm²

Window area, W_a = 10.89 cm²

Area product, A_p = 150 cm⁴

Core geometry, K_g = 37.6 cm⁵

Surface area, A_t = 479 cm²

Step No. 5: Calculate the number of primary turns, N_p using Faraday's Law.

$$N_p = \frac{V_{in}(10^4)}{K_f B_{ac} f A_c}, \text{ [turns]}$$

$$N_p = \frac{(115)(10^4)}{(4.44)(1.6)(47)(13.8)}, \text{ [turns]}$$

$$N_p = 250, \text{ [turns]}$$

Step No. 6: Calculate the current density, J .

$$J = \frac{P_i(10^4)}{K_f K_u B_{ac} f A_p}, \text{ [amps/cm}^2\text{]}$$

$$J = \frac{513(10^4)}{(4.44)(0.4)(1.6)(47)(150)}, \text{ [amps/cm}^2\text{]}$$

$$J = 256, \text{ [amps/cm}^2\text{]}$$

Step No. 7: Calculate the input current, I_{in} .

$$I_{in} = \frac{P_o}{V_{in} \eta}, \text{ [amps]}$$

$$I_{in} = \frac{250}{(115)(0.95)}, \text{ [amps]}$$

$$I_{in} = 2.28, \text{ [amps]}$$

Step No. 8: Calculate the primary bare wire area, $A_{wp(B)}$.

$$A_{wp(B)} = \frac{I_{in}}{J}, \quad [\text{cm}^2]$$

$$A_{wp(B)} = \frac{(2.28)}{256}, \quad [\text{cm}^2]$$

$$A_{wp(B)} = 0.0089, \quad [\text{cm}^2]$$

Step No. 9: Select the wire from the Wire Table, in Chapter 4.

$$AWG = \#18$$

$$A_{wp(B)} = 0.00822, \quad [\text{cm}^2]$$

$$A_{wp} = 0.00933, \quad [\text{cm}^2]$$

$$\left(\frac{\mu\Omega}{\text{cm}}\right) = 209, \quad [\text{micro-ohm/cm}]$$

Step No. 10: Calculate the primary resistance, R_p .

$$R_p = MLT(N_p)\left(\frac{\mu\Omega}{\text{cm}}\right)(10^{-6}), \quad [\text{ohms}]$$

$$R_p = (22)(250)(209)(10^{-6}), \quad [\text{ohms}]$$

$$R_p = 1.15, \quad [\text{ohms}]$$

Step No. 11: Calculate the primary copper loss, P_p .

$$P_p = I_p^2 R_p, \quad [\text{watts}]$$

$$P_p = (2.28)^2(1.15), \quad [\text{watts}]$$

$$P_p = 5.98, \quad [\text{watts}]$$

Step No. 12: Calculate the secondary turns, N_s .

$$N_s = \frac{N_p V_s}{V_{in}} \left(1 + \frac{\alpha}{100}\right), \quad [\text{turns}]$$

$$N_s = \frac{(250)(115)}{(115)} \left(1 + \frac{5}{100}\right), \quad [\text{turns}]$$

$$N_s = 262.5 \text{ use } 263, \quad [\text{turns}]$$

Step No. 13: Calculate the secondary bare wire area, $A_{ws(B)}$.

$$A_{ws(B)} = \frac{I_o}{J}, \text{ [cm}^2\text{]}$$

$$A_{ws(B)} = \frac{(2.17)}{256}, \text{ [cm}^2\text{]}$$

$$A_{ws(B)} = 0.00804, \text{ [cm}^2\text{]}$$

Step No. 14: Select the wire from the Wire Table, in Chapter 4.

$$AWG = \#18$$

$$A_{wp(B)} = 0.00822, \text{ [cm}^2\text{]}$$

$$A_{wp} = 0.00933, \text{ [cm}^2\text{]}$$

$$\left(\frac{\mu\Omega}{\text{cm}}\right) = 209, \text{ [micro-ohm/cm]}$$

Step No. 15: Calculate the secondary winding resistance, R_s .

$$R_s = MLT(N_s)\left(\frac{\mu\Omega}{\text{cm}}\right)(10^{-6}), \text{ [ohms]}$$

$$R_s = (22)(263)(209)(10^{-6}), \text{ [ohms]}$$

$$R_s = 1.21, \text{ [ohms]}$$

Step No. 16: Calculate the secondary copper loss, P_s .

$$P_s = I_o^2 R_s, \text{ [watts]}$$

$$P_s = (2.17)^2(1.21), \text{ [watts]}$$

$$P_s = 5.70, \text{ [watts]}$$

Step No. 17: Calculate the total primary and secondary copper loss, P_{cu} .

$$P_{cu} = P_p + P_s, \text{ [watts]}$$

$$P_{cu} = 5.98 + 5.7, \text{ [watts]}$$

$$P_{cu} = 11.68, \text{ [watts]}$$

Step No. 18: Calculate the transformer regulation, α .

$$\alpha = \frac{P_{cu}}{P_o}(100), \quad [\%]$$

$$\alpha = \frac{(11.68)}{(250)}(100), \quad [\%]$$

$$\alpha = 4.67, \quad [\%]$$

Step No. 19: Calculate the watts per kilogram, W/K. Use the Equation for this material in Chapter 2.

$$W/K = 0.000557(f)^{1.68}(B_{ac})^{1.86}$$

$$W/K = 0.000557(47)^{1.68}(1.6)^{1.86}$$

$$W/K = 0.860$$

Step No. 20: Calculate the core loss, P_{fe} .

$$P_{fe} = (W/K)(W_{fe})(10^{-3}), \quad [\text{watts}]$$

$$P_{fe} = (0.860)(2.33), \quad [\text{watts}]$$

$$P_{fe} = 2.00, \quad [\text{watts}]$$

Step No. 21: Calculate the total loss, P_{Σ} .

$$P_{\Sigma} = P_{cu} + P_{fe}, \quad [\text{watts}]$$

$$P_{\Sigma} = (11.68) + (2.00), \quad [\text{watts}]$$

$$P_{\Sigma} = 13.68, \quad [\text{watts}]$$

Step No. 22: Calculate the watts per unit area, ψ .

$$\psi = \frac{P_{\Sigma}}{A_r}, \quad [\text{watts/cm}^2]$$

$$\psi = \frac{(13.68)}{(479)}, \quad [\text{watts/cm}^2]$$

$$\psi = 0.0286, \quad [\text{watts/cm}^2]$$

Step No. 23: Calculate the temperature rise, T_r .

$$T_r = 450(\psi)^{(0.826)}, \text{ [}^\circ\text{C]}$$

$$T_r = 450(0.0286)^{(0.826)}, \text{ [}^\circ\text{C]}$$

$$T_r = 23.9, \text{ [}^\circ\text{C]}$$

Step No. 24: Calculate the total window utilization, K_u .

$$K_u = K_{up} + K_{us}$$

$$K_{us} = \frac{N_s A_{ws(B)}}{W_a}$$

$$K_{us} = \frac{(263)(0.00822)}{(10.89)} = 0.199$$

$$K_{up} = \frac{N_p A_{wp(B)}}{W_a}$$

$$K_{up} = \frac{(250)(0.00822)}{(10.89)} = 0.189$$

$$K_u = (0.189) + (0.199)$$

$$K_u = 0.388$$

38 Watt 100kHz Transformer Design, Using the Core Geometry, K_g , Approach

The following information is the design specification for a 38 watt push-pull transformer, operating at 100kHz, using the K_g core geometry approach. For a typical design example, assume a push-pull, full-wave, center-tapped circuit, as shown in Figure 7-4, with the following specification:

1. Input voltage, $V_{(min)} = 24$ volts
2. Output voltage #1, $V_{(o1)} = 5.0$ volts
3. Output current #1, $I_{(o1)} = 4.0$ amps
4. Output voltage #2, $V_{(o2)} = 12.0$ volts
5. Output current #2, $I_{(o2)} = 1.0$ amps
6. Frequency, $f = 100\text{kHz}$
7. Efficiency, $\eta = 98\%$
8. Regulation, $\alpha = 0.5\%$