

DESIGNING OFFLINE AC/DC SWITCHING POWER SUPPLIES, BRICK BY BRICK

BY PAUL RAKO • TECHNICAL EDITOR





IT'S A CHALLENGE TO CONVERT HIGH-VOLTAGE AC TO DC WHILE KEEPING EFFICIENCY HIGH AND COST LOW.

In an effort to meet worldwide efficiency requirements, engineers are designing offline power supplies integrating high-efficiency switching-regulator-control circuits. This approach uses less copper and is thus less expensive than that of conventional linear supplies with large transformers and no control IC. Designing these offline switching power supplies, however, brings a difficult set of problems, including EMI (electromagnetic interference), in-rush current, input-capacitor discharge, and universal-input requirements. There are various approaches to dealing with these issues.

COMMON DESIGN PROBLEMS

Because these supplies radiate EMI into space and into the power cord feeding the supply, engineers often place differential and common-mode filters on the input circuit. The filter requires a Class X capacitor across the ac input. The failure of this type of capacitor cannot lead to electric shock but can cause safety problems if you disconnect the supply during high applied line voltage. You can discharge the capacitor with a parallel resistor, but this approach wastes power when the supply is working. Instead, you can use parts such as those in Power Integrations' two-terminal CapZero family of automatic-X-capacitor-discharge ICs, which eliminate power losses but still allow power supplies to comply with safety standards.

You may also need Y capacitors, whose failure can lead to electric shock, from the line to earth ground. These capacitors reduce conducted EMI into



the power cord, but large ones can trip ground-fault outlets and circuit breakers. You can solve radiated EMI into space with tight PCB (printed-circuit-board) layouts and by slowing any fast current transitions in the circuit (**Reference 1**). As a last resort, you can use shielding, which adds cost and may interfere with cooling.

Another problem that can occur when you are designing offline power supplies is their requirement for a large input capacitor, which in turn requires a large pulse of current that charges up the capacitor when you turn on or plug the supply into the wall. Using a large input capacitor reduces the input ripple to your switching stage but causes a greater inrush current, which can trip the ac circuit breaker feeding the supply, damage the rectifier diodes in the input section, or blow fuses in the input circuit. To mitigate these problems, you can add NTC (negative-temperature-coefficient) inrush limiters. When these inrush limiters are cold, they have a high resistance, limiting the inrush-current surge. In the hot state, the limiters have low impedance and allow the supply to deliver full power.

You must be careful when designing systems that have applied intermittent power because the input could lose power. The switching supply would then drain the input capacitor in 100 msec. Restoration of power while the NTC limiters are still hot could cause an unacceptable inrush. To overcome this problem, use control chips with undervoltage lockout. These chips prevent the switching supply from draining the input capacitor when the voltage reaches some threshold. You can design your

AT A GLANCE

- Offline switchers are high-voltage power supplies.
- Many design problems are unique to ac/dc supplies.
- Flyback and forward converters are the most common types of offline switchers.
- Quasiresonant flyback converters have 88% efficiency.
- LLC (inductor/inductor/capacitor) and asymmetrical half-bridge converters reach 93% efficiency.
- Phase-shifted full-bridge converters deliver power greater than 500W.

circuit so that the required energy to charge the input capacitor from this level to line operating levels does not damage the supply or blow the circuit breakers, even if the NTC limiter is hot.

Passive NTC limiters respond to ambient temperature. If your supply must work over large temperature ranges, you face the difficult task of balancing all the requirements and keeping the inrush current low (see **sidebar** “Testing your design”). Another way to solve the inrush-current problem is to put a series FET or another transistor in the input stage (**Figure 1** and **Reference 2**). If you properly size the FET, you can then slowly turn it on, operating it in its linear region and dissipating power. You must ensure that repeated turn-on or turn-off events do not overheat the part.

You must ensure that a failed input capacitor can safely blow a fuse or melt a trace without catching fire or caus-

ing a fire in another component. UL (Underwriters Laboratories) testing is primarily about fire prevention. In addition to examining failure modes, UL can short-circuit your supply output to observe whether it catches fire.

Although an undervoltage lockout keeps the input capacitors charged to reduce subsequent inrush events, you cannot allow these capacitors to stay charged up indefinitely. A constantly charged state would present a safety hazard to service personnel. To deal with this problem, wire a resistor across the capacitor; the resistor drains the capacitor’s charge within a few minutes but is a constant power waste and drain on efficiency. To eliminate this efficiency loss, use a FET in series with the resistor to disconnect it when the supply is on.

After solving the inrush problem, you must decide whether your supply accepts universal inputs. If it does, it will work from worldwide line voltages and frequencies. These inputs can be as extreme as 85V at 60 cycles for Japan and 264V at 50 cycles for Europe. Wide input range causes problems relating to the minimum pulse width at which your supply operates. As the input voltage increases, a conventional PWM (pulse-width-modulated) switching power supply makes narrower pulses. At some point, the pulses become so narrow that the power transistors spend most of their time ramping high or low in their linear region. This linear region exposes the transistors to both significant voltage and significant current, overheating the parts.

To solve the universal-input problem, add transistors to the front end to change the input from a bridge-type rectifier to a push-pull type or use control ICs that support short rise and fall times. These fast transitions may solve the overheating problem but at the expense of greater EMI. Alternatively, you can address these wide input ranges using different topologies, such as PFM (pulse-frequency modulation).

You next must figure out how to power the control IC. The conventional way is to use a series-dropping resistor from the input dc bus to the control chip (**Figure 2**). Although simple, this scheme wastes a significant amount of power in the resistor. If the input bus is 264V ac, the rectified dc bus will be 373V. Control chips operate at 10 or

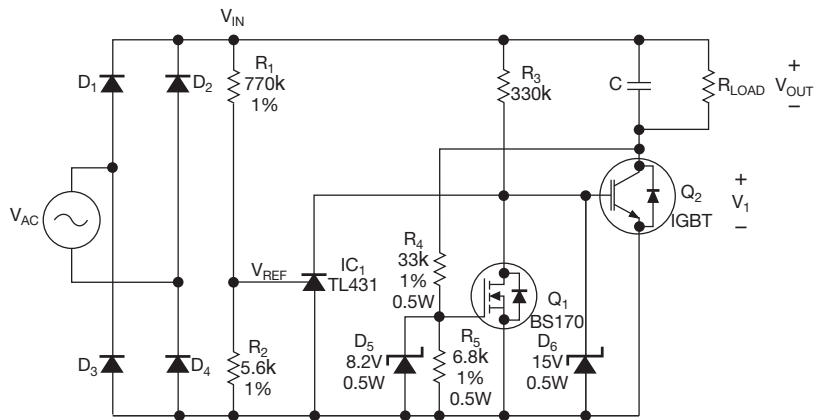

Figure 1 This circuit, a recent *EDN* Design Idea, eliminates the losses of NTC inrush limiters.

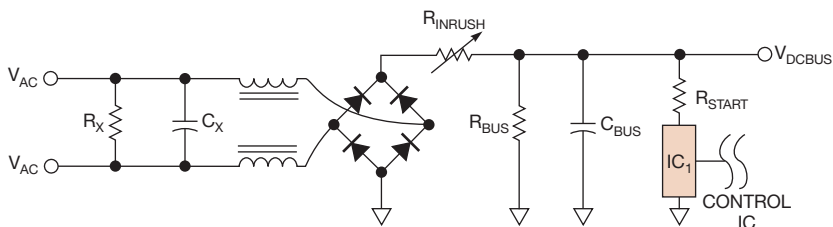

Figure 2 The resistors in this circuit create efficiency losses in the supply. You should switch them or use a chip that internally switches them out of the circuit.

20V and might consume 10 mA of current. The resistor wastes 353V times 10 mA, or 3.53W, of power. You can reduce this waste by using a small winding in the transformer to feed current to the chip once the supply starts up. This technique reduces but does not eliminate the current the supply draws from the dc bus. The wasted power violates the various “green” initiatives and regulations, such as Energy Star and other worldwide standards.

To eliminate the power loss in the start-up resistor, you have to either switch it out with an external FET or use a regulator chip that performs this task. Alternatively, you can use a chip from Power Integrations’ SenZero family, which steers current to any manufacturer’s chip. The chips require an external enable signal. Another option is to use a FET with a normally on depletion mode, such as the high-voltage PFETs from Supertex.

Once you have the control chip, you must select an output device. Regulator ICs have built-in power FETs, whereas controller ICs, which target use in tough ambient conditions, require that you add external FETs. Some designers use IGBTs (insulated-gate bipolar transistors) at powers greater than 1 kW. You can create cost-conscious, low-power designs using conventional bipolar transistors. The CamSemi C2471 chip, for example, controls inexpensive bipolar transistors. Power Integrations’ TopSwitch family integrates the FET on die with a 700V process, whereas Fairchild uses two dice in one package in its FPS product line. Fairchild also makes a complete line of controllers, as do Texas Instruments and STMicroelectronics. Using a controller requires you to select primary-switch transistors, such as those from Vishay, On Semiconductor, International Rectifier, ST-Micro, Ixys, Texas Instruments, and Renesas. Fairchild recently introduced its

SupreMOS FETs with smaller die and cost for a given breakdown voltage.

You might want circuitry to soft-start the supply. If so, you must ensure that the soft-start works properly when power is intermittent. Most control ICs provide a soft-start function, and many regulators and controllers also have built-in protection features for over-temperature and overcurrent. Once external, protection features are now parts of the IC.

OTHER CONSIDERATIONS

All of these design problems are just the start of the design process. You now must select a switching architecture. Part of this task might involve deciding to put the control chip on the secondary side to eliminate sending the feedback voltage over isolation boundaries and to enable synchronous rectification. Synchronous rectification allows you to replace the output diode with FETs that the control chip switches on and off at the proper times. Placing the control chip on the secondary side means, however, that you must send start-up power over the isolation boundary to get the chip working.

Another decision is whether to use current-mode or voltage-mode feedback. Current-mode feedback uses the current in the primary winding as the controlled parameter. This approach eliminates the reactive nature of the primary from the control loop and removes a pole associated with the primary inductance. Many engineers prefer current-mode control because, in this approach, the power supply has one dominant pole and exhibits better stability. Current-mode control also protects the switching transistor and measures current through the transistor at all times, preventing excessive currents that would damage the device.

Many semiconductor companies have begun to tout ICs that use digi-

tal power. Chips that use digital PWM loops are popular in PFC (power-factor-correction) circuits because the fundamental control is 60 Hz, slow enough that almost any digital loop can keep up with it. Digital power is inherently neither superior to nor inferior to analog power. Deciding the internal architecture of the chip is a problem for the semiconductor company (Reference 3). Companies such as iWatt have enjoyed high designer acceptance of their digital-power parts, but the parts' features are more important than their control methods.

Most ac/dc power supplies need output regulation because it compensates for changes in output load and input line voltage. To regulate the output voltage, you must feed the signal back to the control chip. Most ac/dc supplies use an optocoupler such as those from Fairchild and Avago. The supplies

add phase shift and can cause control problems. The optocoupler reduces the bandwidth of the control loop, reducing transient response. Many control chips replace the optocoupler with a sense winding on the transformer. This scheme cannot hold as tight a regulation but does achieve 5% output accuracy. However, iWatt claims that its proprietary primary-sense algorithms can improve accuracy beyond that level. "Cell-phone chargers need tighter control than you can achieve with competing primary-sensing schemes," says Zahid Rahim, iWatt's vice president and general manager.

Alternatively, you can send the analog voltage across the isolation boundary with a delta-sigma modulator, such as those from Avago. As another alternative, you could represent the output voltage as a digital value and send it across the boundary with a digital iso-

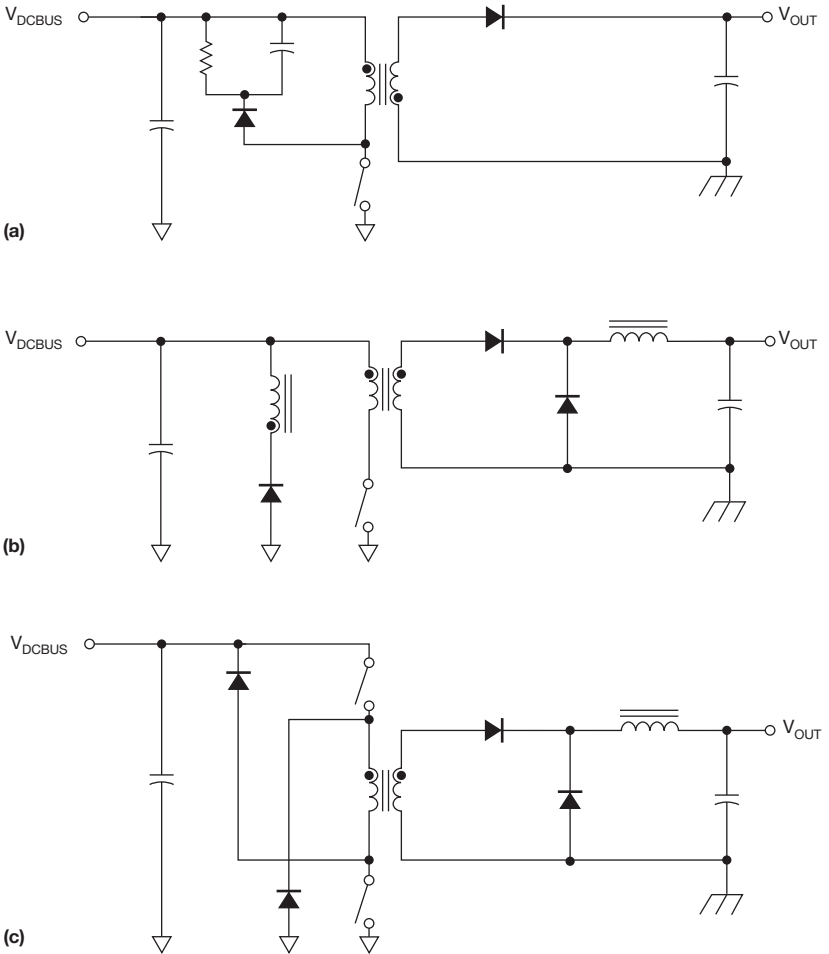

Figure 3 The flyback (a) and forward converter (b) are the workhorses of the industry. The two-switch forward converter (c) eliminates the reset winding.



lator (Reference 4). These alternatives are costly, however, and create phase lags that reduce the control-loop bandwidth. Another approach is to place the control chip on the secondary side and let it control the primary side across the isolation boundary. In that case, you must send isolated start-up power to the chip. You can achieve tighter voltage regulation if the control chip is on the secondary side, according to Richard Garvey, an application manager at Texas Instruments. You need not send the output-voltage feedback across an isolation boundary.

If your design has high power levels or low output voltages, you might want to replace the secondary-side diodes with synchronous FETs. You can control the power supply with the chip on the primary and send the secondary control over the isolation boundary. Texas Instruments' UCC28250 power-supply chip operates in this way. Alternatively, a secondary rectification circuit, such as International Rectifier's IR11672AS secondary-side-driver IC, can sense the power delivery and run independently of the primary control loop.

ARCHITECTURE ABUNDANCE

When designing a switching power supply, you'll find an abundance of available architectures for your design. The architectures include both fixed-frequency PWM and variable-frequency architectures. Among the fixed-frequency architectures is the flyback converter, a classic ac/dc switching power supply (Figure 3). A flyback converter transfers energy when the primary transistor switch is off. Closing a transistor switch allows current to build up in a transformer. When the current is flowing into the primary windings, the diodes on the secondary side block current, and the secondary windings deliver no current to the output. Turning off the input transistor causes the voltage at the drain node to fly to a value higher than the dc input bus. The voltage goes high enough to damage the transistor, so you must limit the excursion of the drain node with a snubber (references 5 and 6).

Flyback power supplies provide good tracking between multiple outputs. Thus, if you regulate a 5V rail with feedback to the control chip, the ± 12 V rails stay fairly close to their nominal

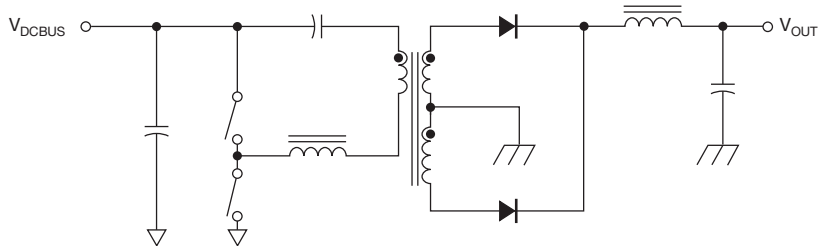

Figure 4 An asymmetrical half-bridge operates at a fixed frequency.

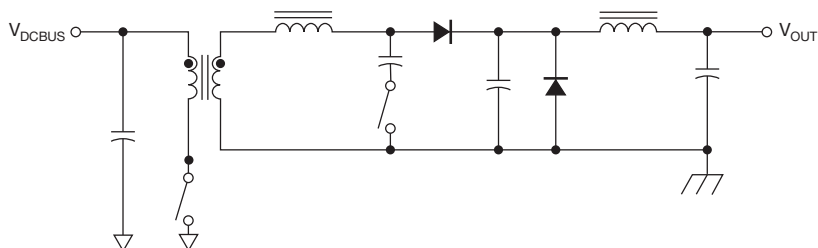

Figure 5 The series-resonant converter, which Vicor developed, shifts frequency as it operates.

values despite varying loads. On the other hand, flyback converters tend to emit more EMI and have worse transient response than do other topologies. The architecture must build current in the primary before it can respond to an output load change, so the switching frequency is a fundamental limit on the transient output response. Fairchild, Texas Instruments, STMicro, Power Integrations, and many other vendors make dozens of flyback control ICs.

When your design reaches power requirements of approximately 60W, you should consider using a forward converter, which transfers power to the output and switches the energy into the primary side. Forward converters, including push-pull devices, have lower secondary ripple current and better efficiency than flyback converters, and they respond more quickly to transient-

load changes. They also can employ a smaller transformer for a given power because they need not store an entire cycle's energy in the core.

Flyback and forward converters have served the industry for decades, but recent eco-friendly initiatives have made them less attractive because they rarely provide more than 85% efficiency. As a result, control chips that support multiple architectures, such as Power Integrations' HyperPFS, have flourished. The chip incorporates PFC and a semi-resonant, asymmetrical, two-switch forward topology.

You can achieve 93% efficiency at 200 to 500W power levels using an asymmetrical half-bridge topology (Figure 4). This architecture suits use in designs having output voltages lower than 24V (Reference 7). The fixed-frequency PWM circuit eases input- and

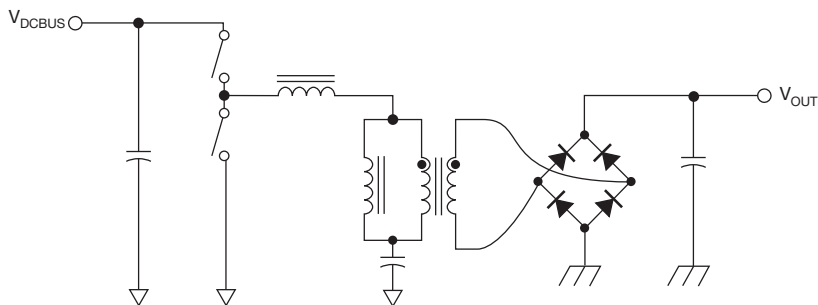

Figure 6 The LLC topology operates with variable frequency and delivers 93% efficiency.

output-filter design by combining series capacitors with the transformer and a series inductor. The inductor can be the transformer's leakage inductance or a discrete inductor, which adds cost and space but has a more predictable value. The asymmetrical half-bridge has a secondary-side output inductor that provides lower ripple current to the output capacitors, making it more attractive for low-voltage or high-current supplies.

For power levels greater than 500W, you should consider a full-bridge architecture using four MOSFETs. This approach fully uses the transformer's windings because it excites the primary with both polarities. The downside of this circuit is that it places stress on the FET switches. One approach to this problem is to use a phase-shifted full-bridge topology (references 8, 9, and 10). You accomplish this task by adding capacitors and fast-recovery diodes across the four FETs. Alternatively, you could use a FREDFET (fast-recovery epitaxial-diode field-effect transistor). You then use a control IC, such as the TI UCC2895 or UCC28950, which adds secondary-side rectification.

Another class of offline converters regulates the output by varying the pulse frequency. Vicor decades ago pioneered the series-resonant architecture, which, like other varying-frequency architectures, is more complex and more efficient than the fixed-frequency types (Figure 5). FETs usually switch in 0V or 0A modes, so these supplies emit less EMI and put less stress on the switches. A sine wave excites the transformer, requiring a tank circuit in the primary side. The sine wave has few harmonics, yielding fewer losses in the transformer. A downside of these devices' broad frequency range is that it is more difficult to design input- and output-filtering circuits for them.

Another variable-frequency architecture includes quasiresonant flyback supplies (Reference 11). You can improve these supplies' efficiency to 88%, and you can add a capacitor across their FETs to make the supplies resonant. This capacitor reacts with the transformer's leakage inductance to form a resonant tank. The circuit benefits from 0V or 0A FET switching. The control IC ensures that the transformer's primary current always returns to 0A. For this reason, the

circuit's frequency changes with the load. By operating at the boundary or the transition mode, at which the primary current has reached 0A, the devices eliminate reverse-recovery loss in the output rectifier. A plethora of control ICs are available, including TI's UCC28610, Power Integrations' PLC810PG, and CamSemi's CC2163.

The LLC (inductor/inductor/capacitor) switching power supply is a true resonant architecture (Figure 6 and references 12, 13, and 14). You operate the circuit at a frequency at which the tank is inductive. Lower frequencies see less impedance and deliver more power, and lower loads create an increase in frequency. LLC devices in-

Go Direct & Stretch



Your Budget!

Get more performance, more power and more product for your money. At **MicroPower Direct** we provide fast delivery, great customer service and experienced technical support on well over 4,000 standard, high performance power products. All at very low cost. Our products include:



DC/DC Converters



Over 2,000 DC/DC's like our **NEW** ultraminiature **ACP100** & **LCP100**. Products range from 1W to 40W, most with industry standard pin-outs.

AC/DC Power Supplies

Over 2,000 AC/DC's like our **NEW** compact **MPU240**. Products range from 3W to 800W; with open frame, module, u-channel, enclosed, SIP and DIN models available.

LED Drivers

A full range of LED drivers, including our **NEW** ultra-wide input **LD48** series. Products range from 150 mA to 1A constant current output. AC input models will be released shortly.

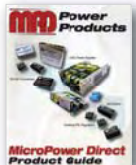

Don't sacrifice performance or service for price. Call **MPD** today for a surprisingly low cost quotation. For product datasheets & samples, go to:

Call Now
For our new
Product Guide

www.micropowerdirect.com

MicroPower Direct

We Power Your Success - For Less!

TEL: (781) 344-8226 FAX: (781) 344-8481 E-Mail: sales@micropowerdirect.com



TESTING YOUR DESIGN

Once you design the input, start-up, control, architecture, and power devices for a switching power supply, you can test your design. Experienced ac/dc-power-design engineers understand that safety is a constant concern. Keep one hand in your pocket while probing so that current does not conduct across your heart. Testing on wooden benches is safer than on metal ones because touching a high-voltage node on a wooden bench does not cause a short circuit to the parts of your body touching the bench.

Even small supplies store enough energy to blow up components. Your prototype most likely has a backward-polarized capacitor. Thus, you must wear safety glasses or a full-face shield when troubleshooting your design.

Test your design over all the ambient temperatures it will encounter. The applied ac does not necessarily start at 0V. A user can close a switch or plug in a supply at the moment the ac voltage is at its peak, causing a large inrush current.

Avoid applying full ac voltage to your design the first time you try it. Use a VARIAC (variable-ac) transformer to slowly increase the ac input voltage. Testing the input section requires a laboratory ac-power

supply, such as those from California Instruments, Pacific Power Source, Elgar, or Kikusui. These instruments can vary input voltage over the universal range and supply 50- or 60-Hz frequencies. You can use an isolation transformer to make the negative rail of the dc bus into a chassis common for your oscilloscope. You can also use differential probes, but they rarely have adequate voltage capability for primary circuits.

To understand a switching power supply, it is essential for you to have at least one current probe with as great a bandwidth as possible. Most engineers comprehend resistive circuits, but reactive circuits with capacitors and inductors act in non-intuitive ways. Looking at the voltage of a node with an oscilloscope does not tell you what is going on. You must understand both the voltage at the node and the current passing through it.

Power supplies are servo systems. You feed back the output voltage to a control chip and add components to compensate that feedback loop. All the principles of control theory apply to power supplies. You must ensure that your design is stable over all line voltages, loads, and temperatures. You can apply a step load to the output and observe the ring-

ing on the waveform as the supply recovers. The thorough way to test a supply's stability is with a network analyzer. Ridley Engineering and Venable Instruments make specialized network analyzers for power-supply applications. The source excitation in these instruments is isolated, so you can inject a signal into the feedback loop of your supply. Alternatively, you can combine a conventional network analyzer, such as the 200-MHz Agilent HP3577, with an isolation transformer. Omicron makes the B-WIT-100 and network analyzers for this purpose.

Once you have set up the network analyzer, get a bode diagram of the gain and phase plots of your power supply's control loop over frequency. Power-supply engineers leave 30 to 60° of phase margin. Measuring EMI (electromagnetic interference) requires instruments such as Kikusui's harmonic and flicker analyzer to evaluate conducted noise into the ac-power cord. Dozens of instruments will help you measure radiated noise. Using a control IC that dithers the PWM (pulse-width-modulated) frequency lowers the measured EMI but does not reduce EMI. It reduces only the measurement results from swept-receiver instruments.

clude Fairchild's FSFR2100 regulator and FAN7621 controller and International Rectifier's IRS27951S.

NO MAGIC

The many challenges inherent in designing offline switching power supplies are daunting. If you are new to switching-power-supply design, you should not start with offline switchers because they involve significant safety hazards. On the other hand, there is no magic to them. Look at other designs for inspiration (Figure 7). Prowl the electronics-salvage yards and find a supply that outputs 300W; you could use that supply's transformer to make your own 300W device. Try changing the architecture or increasing the switching frequency to see what happens. Playful experimentation will bring the intuition

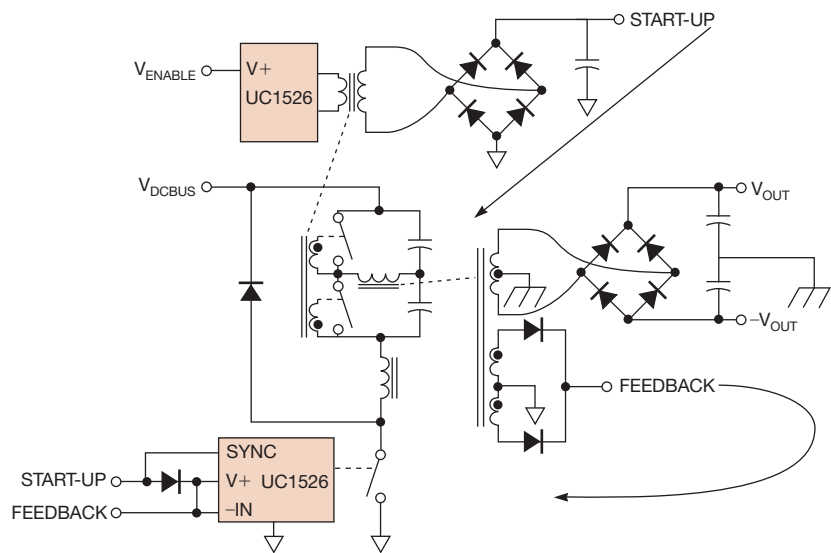

Figure 7 This compound power supply finds use in military systems. It has a buck converter that varies the voltage to a half-bridge converter that operates at a 50% duty cycle.

and experience you need to design off-line switchers.

Engineers who take on a design challenge often risk their safety to design high-voltage circuits. They enjoy the difficulties of understanding reactive circuits that behave in a nonintuitive manner. They read, study, and keep up with developments, and they often enjoy making the world a better place by squeezing every last percentage point of efficiency from a design. You are not alone. The vendors' application engineers will help you conceive, build, and test your ac/dc power supply. **EDN**

REFERENCES

- 1 Rako, Paul, "Circulating currents: The warnings are out," *EDN Europe*, November 2006, <http://bit.ly/h3rofF>.
- 2 Castro-Miguens, JB, and C Castro-Miguens, "Limit inrush current in low-to medium-power applications," *EDN*, Nov 4, 2010, pg 44, <http://bit.ly/eMbUNT>.
- 3 Rako, Paul, "Digital power—without the hype," *EDN*, April 22, 2010, pg 25, <http://bit.ly/hCEHub>.
- 4 Rako, Paul, "Draw the line: Isolation shields systems from shocking surprises," *EDN*, Sept 3, 2009, pg 22, <http://bit.ly/hT9Djw>.
- 5 Ridley, Ray, "Flyback Converter Snubber Design," *Switching Power*

FOR MORE INFORMATION

Agilent
www.agilent.com

Avago
www.avagotech.com

California Instruments/Elgar
www.elgar.com

CamSemi
www.camsemi.com

Elgar
www.elgar.com

Energy Star
www.energystar.gov

Fairchild Semiconductor
www.fairchildsemi.com

International Rectifier
www.irf.com

iWatt
www.iwatt.com

Ixys
www.ixys.com

Kikusui
www.kikusui.co.jp

Omicron
www.omicron.at

On Semiconductor
www.onsemi.com

Pacific Power Source
www.pacificpower.com

Power Integrations
www.powerint.com

Renesas
am.renesas.com

Ridley Engineering
www.ridleyengineering.com

STMicroelectronics
www.st.com

Supertex
www.supertex.com

Texas Instruments
www.ti.com

Underwriters Laboratories
www.ul.com

Venable Instruments
www.venable.biz

Vicor
www.vicor.com

Vishay
www.vishay.com

Magazine, 2005, <http://bit.ly/gcXzpd>.

6 "Design Guidelines for RCD Snubber of Flyback Converters," Application Note AN-4147, Fairchild Semiconductor, 2006, <http://bit.ly/fgnhom>.

7 "Designing asymmetric PWM half-bridge converters," Application Note AN-4153, Fairchild Semiconductor, 2008, <http://bit.ly/dOOH6b>.

8 Mappus, Steve, "Control Driven Synchronous Rectifiers In Phase Shifted Full Bridge Converters," Application Note SLUA287, Texas Instruments, March 2003, <http://bit.ly/iangqz>.

9 Aigner, Hubert; Kenneth Dierberger; and Denis Grafham, "Improving the Full-bridge Phase-shift ZVT Converter for Failure-free Operation Under Extreme Conditions in Welding and Similar Applications," Application Note APT9803, Advanced Power Technology, December 1998, <http://bit.ly/eYCma9>.

10 Jang, Yungtaek, and Milan M Jovanovic, "A New Family of Full-Bridge ZVS Converters," *IEEE Transactions on Power Electronics*, Volume 19, No. 3, May 2004, <http://bit.ly/eeVz5u>.

11 Harper, Jon, "Selecting the right topology for energy-saving power supplies," *Embedded.com*, May 14, 2009, <http://bit.ly/ihWzGl>.

12 "An introduction to LLC resonant half-bridge converter," Application Note AN2644, STMicroelectronics, September 2008, <http://bit.ly/hKGjya>.

13 Choi, Hang-Seok, "Design Consideration of Half-Bridge LLC Resonant Converter," *Journal of Power Electronics*, Volume 7, No. 1, January 2007, <http://bit.ly/eBU7FX>.

14 Yang, Bo, "Topology investigation of front end DC/DC converter for distributed power system," *Electronic Theses and Dissertations*, Virginia Polytechnic Institute, Sept 12, 2003, <http://bit.ly/fLnTYO>.

You can reach
Technical Editor
Paul Rako at
1-408-745-1994
and paul.rako@ubm.com



Leading Embedded Development Tools



A full featured development solution for ARM-powered Linux and Android platforms.

ARM

1-800-348-8051
www.arm.com/ds5