

DESIGN NOTES

Ultralow Noise Switching Power Supplies Simplify EMI Compliance – Design Note 316

David Canny

Introduction

Most electronic products must pass electromagnetic interference (EMI) compliance tests—such as the FCC Part 15 rules in the US—before they can be released into the market. When a company's product fails EMI compliance tests, the company loses control of the development process, shipping dates begin to slip, projected revenues diminish and expenses start piling up. Furthermore, excessive noise can interfere with sensitive electronics within the product itself. So it is essential that electronic products are designed from the beginning with EMI attenuation in mind. Often the EMI compliance problem lies in the product's switching power supply. In these cases, the best solution is prevention by using an ultralow noise switching power supply in the initial design, rather than adding shields and filters to the product after the fact.

Circuit Description

Figure 1 shows the LT[®]3439, one of several low noise switchers available from Linear Technology. Ultralow noise and low EMI are achieved by controlling both the output switch voltage and current slew rates. This switching architecture is particularly well suited to noise-sensitive systems such as industrial sensing and control, data conversion and wideband communications.

DC/DC push-pull topologies like the one shown in Figure 1 are commonly used in low noise systems because they offer relatively low input ripple current to the power supply circuit. Nevertheless, DC/DC switcher topologies generate high frequency harmonics across the transformer primary windings (or inductor in the case of some topologies). The transformer provides little impedance to these differential mode harmonics as they are magnetically

LT, LTC and LT are registered trademarks of Linear Technology Corporation.

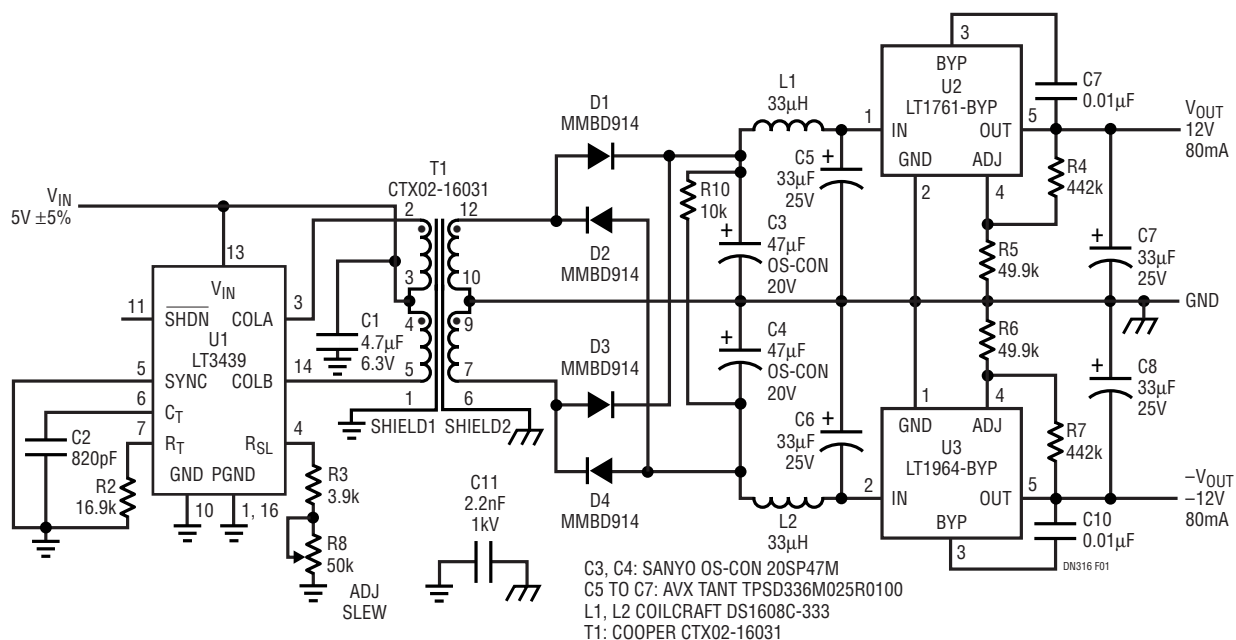

Figure 1. 5V to ±12V Ultralow Noise Switching Power Supply

coupled across to the secondary winding. These high frequency harmonics on the secondary winding are difficult to suppress. Even with an output filter inductor, the high frequency harmonics pass through the filter inductor to the output via the inductor's parasitic capacitance. The best solution for attenuating the high frequency harmonics is to use a low noise switcher like the LT3439 to limit the voltage and current switching slew rates.

The LT3439 in Figure 1 drives the transformer T1 that produces isolated positive and negative output voltages. The two LT3439 internal switches are turned on out of phase at 50% duty cycles. Both of these switches operate at the oscillator frequency set by R2 and C2. During a switch's on time, V_{IN} is applied across the respective half primary side of the push-pull transformer. The voltage on the secondary side of the transformer is basically V_{IN} times the turns ratio of transformer T1. The diodes D1 to D4 rectify the secondary voltages. Capacitors C3 to C6 and inductors L1 and L2 filter the input voltage to the linear regulators.

The high frequency harmonics on the collector Pins 3 and 14 and throughout the circuit are reduced by as much as

40dB compared to a regular switcher by programming the output switch voltage and current slew rates using R8. The secondary winding of the center-tapped transformer can be wound to produce any desired output voltage based on the input voltage. The two linear regulators, U2 and U3, regulate the output voltages to $\pm 12V$. The transformer's Faraday shield blocks primary-to-secondary common mode noise while the 2.2nF capacitor C11 provides a low impedance return path for any primary-to-secondary currents through parasitic capacitances. Figure 2 shows the output noise on the 12V_{OUT} line (see Reference 1 for low noise measurement techniques).

Conclusion

Ultralow noise switchers simplify product EMI compliance and help avoid last minute shipping delays. They reduce the high frequency harmonics associated with regular switchers by as much as 40dB while lower frequency harmonics are effectively suppressed by output filter inductors and capacitors.

References

1. Williams, J., "A Monolithic Switching Regulator with 100mV Output Noise." Linear Technology Corporation, Application Note 70.

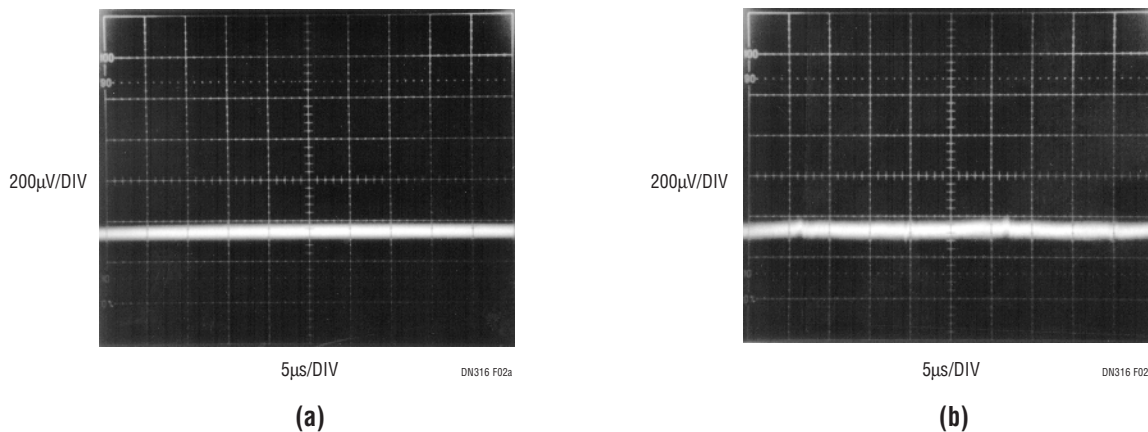

Figure 2. (a) Test Setup Noise Floor. (b) 12V_{OUT} Noise at 80mA. Both Traces Were Captured with a 100MHz Measurement Bandwidth

Data Sheet Download

<http://www.linear.com/go/dnLT3439>

For literature on our Low Noise Switchers, call **1-800-4-LINEAR**. For applications help, call (408) 432-1900, Ext. 2759