



DESIGN NOTES

No Design Switching Regulator 5V Buck-Boost (Positive to Negative) Regulator – Design Note 49

Ron Vinsant

Introduction

This simple, no design regulator, operates with an input between 4.5V DC and 40V DC. It provides a -5V output at a maximum output current of 1A to 3A depending on input voltage.

This converter is based on the Linear Technology LT1074 switching regulator IC. This device needs only a few external parts to make up a complete regulator including thermal protection and current limit. This design uses off-the-shelf parts for low cost and easy availability of components. Specifications for the circuit are in Table 1.

Circuit Description

Figure 1 shows the schematic of the circuit. For the purpose of this explanation assume that the output is at a constant -5V DC and that the input voltage is greater than +4.5V DC.

At intervals of $\approx 10\mu\text{s}$ (100kHz) the control portion of the LT1074 turns on the switch transistor between the V_{IN} and V_{SW} pins impressing a voltage across the inductor, L1. This causes current to build up in the inductor.

The control circuit determines when to turn off the switch during the $10\mu\text{s}$ interval to keep the output voltage

at -5V DC. When the switch transistor turns off, the magnetic field in the inductor collapses and the polarity of the voltage across the inductor changes to try and maintain the current in the inductor. This current in the inductor is now directed (due to the change in voltage polarity across the inductor) by the diode, D1, to the load. The current will flow from the inductor until the switch turns on again, (continuous operation) or until the inductor runs out of energy (discontinuous operation).

C2 is a low ESR type electrolytic capacitor that is used in conjunction with L1 as the output filter. C3 and L2 form a post filter that reduces output ripple further.

Referring back to Figure 1, the divider circuit of R1, R2, R3 and R4 is used to set the output voltage of the supply against an internal voltage reference of 2.21V DC.

R3, R4, C3 and C4 make up the frequency compensation network used to stabilize the feedback loop.

Conclusion

This Design Note demonstrates a fully characterized positive to negative converter circuit that is both simple and low cost. This design can be taken and reliably used in a production environment without the need for any custom magnetics. A P.C. board layout and FAB drawing are available from Linear Technology.

Table 1. Performance Summary (Operating Temperature Range 0°C to 50°C)

Input Voltage Range		+4.5V to +40.0V DC	
Output	Output Voltage ($\pm 0.15\text{V DC}$)	-5.00V DC	
	Max Output Current At $V_{IN} = 4.5\text{V DC}$	1.0A DC	
	Max Output Current At $V_{IN} = 40.0\text{V DC}$	3.5A DC	
	Typical Output Ripple at $I_{OUT} = 2.5\text{A DC}$ @ Switching Frequency	With Optional Filter (L2 & C5) Without Optional Filter (L2 & C5)	50mVp-p 300mVp-p
	Load Regulation $V_{IN} = 4.5\text{V DC}$	At $I_{OUT} = 0.1\text{A DC}$ to 1.0A DC	0.6%
	Line Regulation $I_{LOAD} = 1\text{A}$	At $V_{IN} = 4.5\text{V DC}$ to 40.0V DC	0.2%

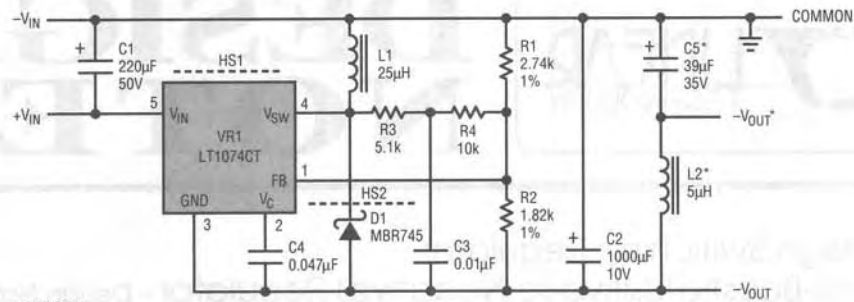

* OPTIONAL

$$-V_{OUT} = 2.21 \left[1 + \frac{R1 \parallel (R3 + R4)}{R2} \right]$$

DC003 - SCH01

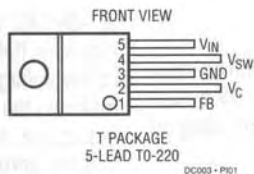

Figure 1. Package and Schematic Diagrams

Table 2. Parts List

REFERENCE DESIGNATOR	QUANTITY	PART NUMBER	DESCRIPTION	VENDOR
PCB	1	003A	PCB FAB, Buck-Boost Converter	LTC
D1	1	MBR745	Diode, Schottky, 7A, 45V	Motorola
HS2	1	6038B-TT	Heatsink	Thermalloy
VR1	1	LT1074CT	Switching Regulator, 100kHz	LTC
HS1	1	7020B-MT	Heatsink	Thermalloy
C1	1	UPL1H221MPH	Cap, Alum Elect, Low ESR, 220µF, 50V	Nichicon
C2	1	LXF10VB272M12X30LL	Cap, Alum Elect, Low ESR, 1000µF, 10V	United Chemicon
C3	1	CK06BX103K	Cap, Ceramic, 0.01µF, 100V	AVX
C4	1	CK05BX473K	Cap, Ceramic, 0.047µF, 100V	AVX
C5	1	UPL1V390MAH	Cap, Alum Elect, Low ESR, 39µF, 35V	Nichicon
L1	1	CTX 25-5-52	Inductor, 25µH, 5A	Coiltronics
L2	1	CTX5-5-FR	Inductor, 5µH, 5A	Coiltronics
R1	1	MF 1/8W 2.74kΩ	RES, MF, 1/8W, 1%, 2.74kΩ	
R2	1	MF 1/8W 1.82kΩ	RES, MF, 1/8W, 1%, 1.82kΩ	
R3	1	CF 1/4W 5.1kΩ	RES, CF, 1/4W, 5%, 5.1kΩ	
R4	1	CF 1/4W 10kΩ	RES, CF, 1/4W, 5%, 10kΩ	

For literature on our Switching Regulators, call (800) 637-5545. For applications help, call (408) 432-1900, Ext. 456