

Design Note

COMBINED LATCH/RESET/HICCUP FUNCTIONS
General Circuit

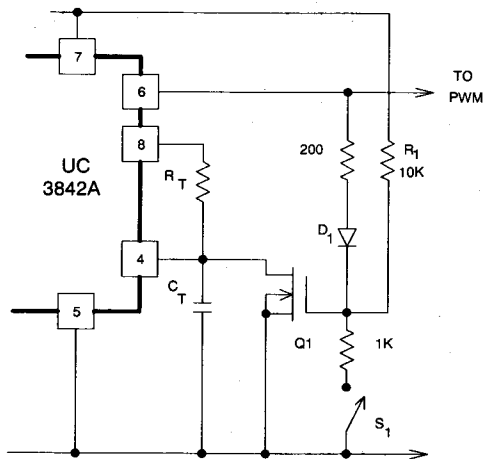

OVER-TEMPERATURE PROTECTION
using 50 to 100Ω thermocouples

