

# A 70W Boost-Buck (Ćuk) Converter Using HEXSense™ Current-Mode Control

(HEXSense and HEXFET are trademarks of International Rectifier)

by R. Pearce, D. Grant

## Introduction

International Rectifier's range of HEX-Sense Power MOSFETs with integral current sensing are ideal switching devices for current-mode control Switched-Mode Power Supplies (SMPS). The current sensing facility of these HEXFETs can be used to provide the current feedback signal required by the pulse-width modulation controller, thereby eliminating the series resistor or current transformer normally required in such applications.

The general use and basic characteristics of Current Sense HEXFETs are described in Application Note AN-959, "An Introduction to the HEX-Sense Current-Sensing Device," and the use of these devices in Switched-Mode Power Supplies is described in Application Note AN-960, "Using HEXSense Current-Sense HEXFETs in Current-Mode Control Power Supplies." [References 1 and 2]

This application note provides a further illustration of how the current sense facility of the HEXSense devices may be used to implement current-mode control in SMPS.

## Description of the SMPS

The power supply is based on the boost-buck (Ćuk converter) circuit [References 3 and 4]. The targeted performance for the supply is as follows:

Input voltage 48V dc  
Output voltage 28V dc  
Output current 2.5 Amps  
Switching frequency 50 kHz  
Full load efficiency 76%  
Output regulation 0.7%  
Input regulation 0.7%

Current-mode control is implemented by the use of the popular 3842 IC as controller and the International Rectifier IRC530 Current Sense HEXFET for current-sensing (see Figure 1). The circuit includes a transformer and therefore provides a non-inverted output. The output is non-isolated but the presence of the transformer allows the circuit to be readily adapted to give an isolated output by the inclusion of isolation in the voltage feedback path.

## Circuit Operation

The operation of the boost-buck converter circuit is illustrated in Figure 2. Figure 2a shows the basic circuit configuration without coupling between the input and output reactors. When Q1 is on, current flows from the input to charge inductor L1. At the same time capacitor C1 is discharging into Cout via L2. Thus the current in Q1 at this time is the sum of the input and output currents. When Q1 turns off, the input current, with the assistance of the energy stored in L1, charges C1 via D1. The output current continues to circulate via D1. Q1 then turns on again repeating the cycle.

An important characteristic of the boost-buck converter is that the input and output currents are non-pulsating although in the version without coupled inductors they do contain a ripple component. If the input and output inductors are coupled as shown in Figure 2b, the ripple component in the output current may be eliminated when there is the appropriate degree of coupling between the two inductors.

It can be seen from Figures 2a and 2b that the polarity of the output vol-

tage is inverted with respect to the input voltage. This is often inconvenient so that it will be necessary to include a transformer in the circuit as shown in Figure 2c in order to obtain the same polarity of input as output. The only circuit modification required to allow the inclusion of the transformer is the division of capacitor C1 into C1 and C2. The primary and secondary windings of the transformer may be linked for a non-isolated output or left separate for an isolated output. Transformer ratios other than unity may be used for scaling the dc conversion ratio. If a non-unity ratio is used for the transformer, a non-unity ratio must also be used for the windings of the coupled inductors.

## Design Criteria

The steady state operation of the circuit is governed by the criteria that neither the inductor nor the transformer windings can have a net dc voltage across them. Similarly, the capacitors cannot pass a net dc current. In an idealized situation the voltage waveforms for the circuit are as shown in Figure 3.  $\delta$  is the conduction duty cycle of Q1 and the output voltage is given by:

$$V_{out} = \frac{\delta}{1-\delta} V_{in}$$

The maximum voltage experienced by Q1 and D1 in an ideal situation is equal to the sum of the input and output voltages. In practice parasitic and leakage inductances will produce overshoot of the voltage waveform which may need to be accommodated in the choice of HEXFET voltage rating. Typical waveforms are shown in Figure 4.

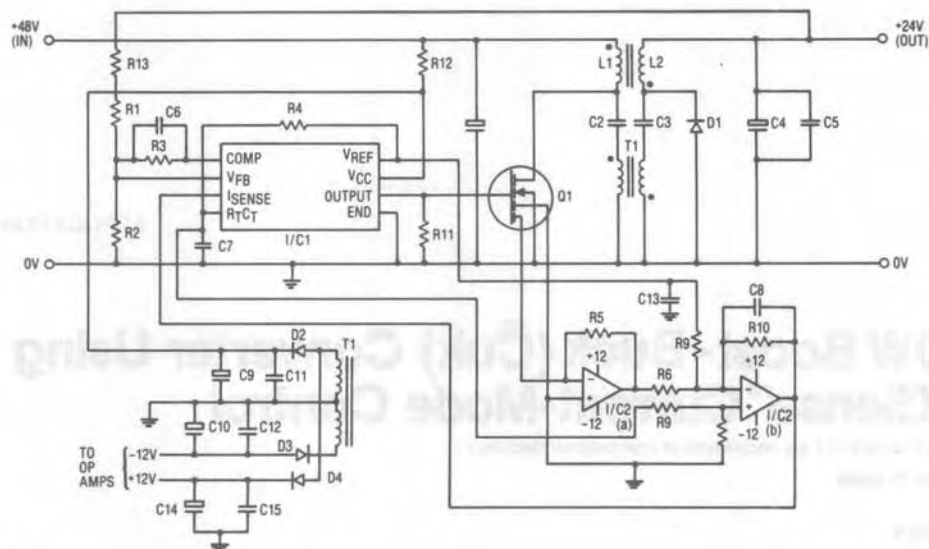

#### Components List.

C1	0.1 $\mu$ F, 100V Polycarbonate
C2	2.2 $\mu$ F, 250V Polycarbonate
C3	2.2 $\mu$ F, 250V Polycarbonate
C4	470 $\mu$ F, 63V Low ESR
Electrolytic	
C5	100 nF
C6	22 nF
C7	22 nF
C8	100 pF
C9	470 $\mu$ F, 16V
C10	10 $\mu$ F, 16V

C11	100 nF
C12	100 nF
C13	100 nF
C14	10 $\mu$ F, 16V
R1	18k
R2	1.8k
R3	220k
R4	680 Ohms
R5	180 Ohms
R6	10k
R7	220k

R8	12k
R9	560k
R10	10k
R11	100k
R12	12k, 1/2 W
R13	150 Ohms
D1	BYV29-300
D2-D4	1N4148
IC1	CS3842A
IC2	TL072
Q1	IRC 830

L<sub>1</sub>, L<sub>2</sub> Bifilar windings of 58T of 0.8mm dia. on ETD 39 with 2mm gap using 3C8 Ferrite.  $L \approx 316 \mu$ H,  $R = 0.7 \Omega$

L<sub>3</sub> Two turns on a 5mm 3E2 Ferrite toroid.

T<sub>1</sub> Bifilar windings of 64T of 0.8mm dia on ETD 34 (3C8). Auxiliary windings of 30T each of 0.2mm dia. wire.  $L_p = 10$  mH,  $R = 1.0 \Omega$

Figure 1. Schematic diagram of supply.

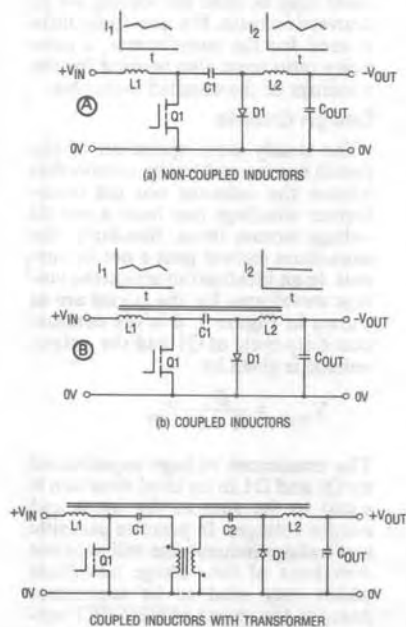

Figure 2. Derivation of circuit.

Referring to Figure 1, L<sub>2</sub> and C<sub>4</sub> may be chosen as for the filter of a buck converter. C<sub>2</sub> and C<sub>3</sub> must be adequate to accommodate the relatively high ripple current that they must conduct. The self-inductance of transformer T<sub>1</sub> must be significantly larger than both the input and output choke inductances so as not to interfere with the basic converter operation. The resonant circuits formed by L<sub>1</sub> and C<sub>1</sub>, L<sub>p</sub> and C<sub>2</sub>, and L<sub>2</sub> and C<sub>2</sub> must have resonant frequencies well below the 50 kHz switching frequency of the converter.

For operation in the continuous mode it is necessary that:

$$\frac{2 f_s}{R_{load}} \left\{ \frac{L_1 L_2}{L_1 + L_2} \right\} \geq 1 \quad \text{where } f_s \text{ is the switching frequency.}$$

In fact, the circuit will operate stably in the discontinuous mode as can be demonstrated by removing the core from L<sub>1</sub> and L<sub>2</sub>. However, this results in a trapezoidal switch current and is not an optimum mode of operation.

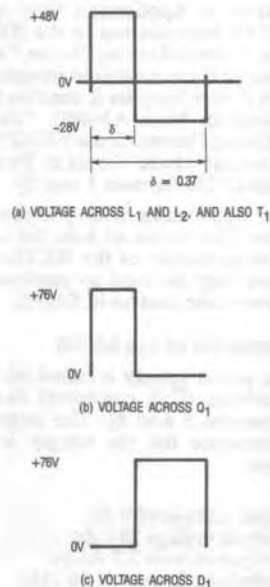

Figure 3. Ideal voltage waveforms.

### The Control Circuit

The control circuit is based on the 3842 PWM integrated circuit (IC) using current-mode control. The current sense signal must be of high quality since it provides the ramp input to the PWM comparator. The current signal is obtained by presenting a virtual-earth to the current sense pin of Q1. The virtual-earth method of sensing has the advantage that the current sense ratio is relatively unaffected by the device temperature and other circuit conditions. Full details of how the ratio is affected by changes in the operating conditions are given in the data sheet for each device.

The current flowing out of the sense cells of Q1 is balanced by the current flowing through R5, so as to maintain the inverting input of the amplifier at virtually the same potential as the non-inverting input. Since the typical current sense ratio for the IRC530 is 1665, the output of the first operational amplifier is given by:

$$V_s = \frac{-I_D}{1665} \times 180 = -I_D \times 0.108 \text{ Volts}$$

Since the threshold for the current limit function of the 3842 is 1 Volt, the maximum value of any current pulse can be set by making the current signal at the limiting current value equal to 1 Volt. If slope compensation is achieved by adding a ramp to the current signal then this must be allowed for when choosing the current sensing sensitivity.

The signal from the first operational amplifier is inverted and therefore a second operational amplifier is required to provide a signal of the appropriate polarity. This is a convenient point at which to add slope compensation to the current signal (from pin RtCt of the 3842). The addition of the ramp provides damping for the current loop and allows the converter to be operated at duty cycles greater than 50%. The 3842 ramp has a dc offset which is nulled by the input from Vref of the 3842 via R9. Perfect cancellation of the offset is not necessary. The feedback capacitor, C8, in the second amplifier stage provides filtering for the current spikes generated by the reverse recovery current of D1 flowing in Q1 at turn-on. If not eliminated, this spike could result in premature turn-off. The current sense signal, as presented to the 3842, is shown in Figure 5.

### Auxiliary Supplies

Auxiliary supplies are required for the 3842 and for the operational amplifiers. These supplies are derived

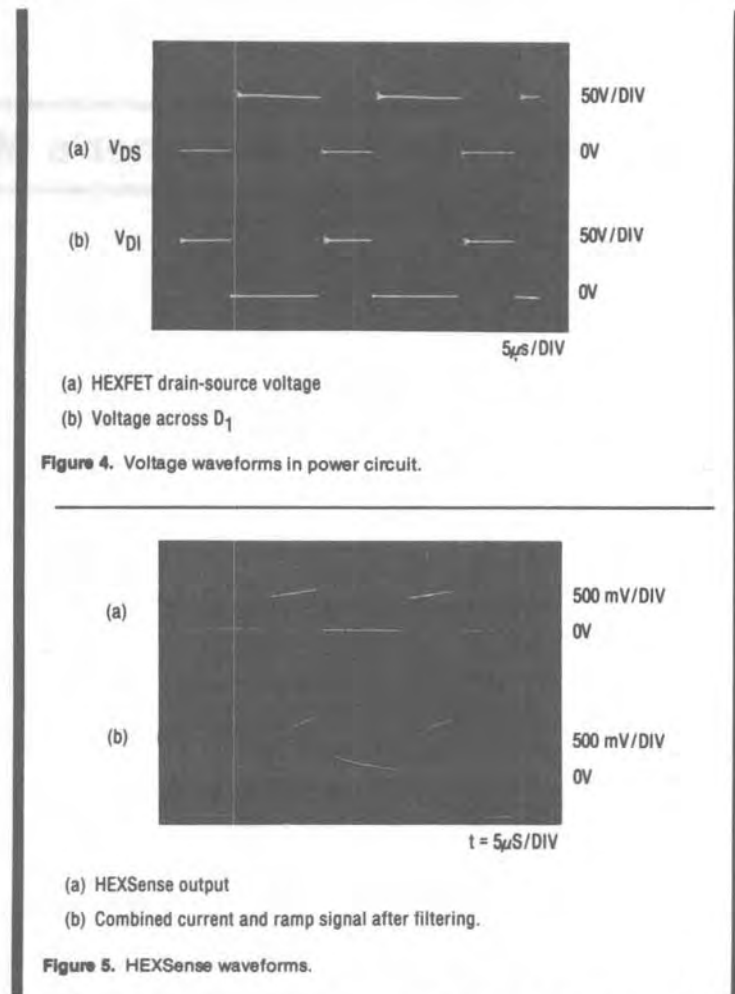

(a) HEXFET drain-source voltage  
(b) Voltage across D<sub>1</sub>

Figure 4. Voltage waveforms in power circuit.

(a) HEXSense output  
(b) Combined current and ramp signal after filtering.

Figure 5. HEXSense waveforms.

from an auxiliary winding on the output transformer. The 3842 features a low start-up current facility and thus R12 is used to trickle charge C9 to provide a supply to the IC for starting. When the voltage on C9 exceeds the under-voltage lockout threshold the 3842 becomes active. Because the operational amplifiers are still inoperative at this stage, the duty cycle will be at a maximum. C4 will charge up with this maximum duty cycle in effect until C14 and C10 are sufficiently charged to operate the operational amplifiers thereby providing a current feedback signal to the controller. A separate positive supply is needed for the operational amplifiers so that they do not draw current during the trickle charging period.

### Conclusion

The built-in current sensing facility of International Rectifiers range of HEXSense devices are suitable for

use in current-mode control SMPS circuits.

### Note

The publication of any circuit or circuit technique in this application note does not guarantee that it is free from patent protection (Reference 4 below). □

### References

1. "An Introduction to the HEXSense Current-Sensing Device." International Rectifier Application Note AN-959.
2. "Using HEXSense Current Sense HEXFETs in Current-Mode Control Power Supplies." International Rectifier Application Note AN-960.
3. "A New Optimum Topology Switching DC-to-DC Converter." S. Cuk and R. D. Middlebrook. Proceedings of the IEEE Power Electronics Specialist Conference 1977.
4. "A DC-DC Switching Converter." S. Cuk and R. D. Middlebrook. Patent Application, Cal. Tech. CIT 1497, June 1977.