

## A Simple Ultra-Low Dropout Regulator

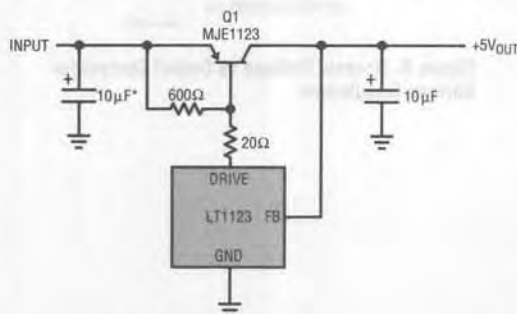
Jim Williams

Switching regulator post regulators, battery powered apparatus, and other applications frequently require low drop-out linear regulators. Often, battery life is significantly affected by the regulator's dropout performance. Figure 1's simple circuit offers lower dropout voltage than any monolithic regulator. Dropout is below 50mV at 1A, increasing to only 450mV at 5A. Line and load regulation are within 5mV, and initial output accuracy is inside 1%. Additionally, the regulator is fully short circuit protected, and has a no load quiescent current of 600 $\mu$ A.

Circuit operation is straightforward. The 3-pin LT1123 regulator (TO-92 package) servo controls Q1's base to maintain its feedback pin (FB) at 5V. The 10 $\mu$ F output capacitor provides frequency compensation. If the circuit is located more than six inches from the input

source the optional 10 $\mu$ F capacitor should bypass the input. The optional 20 $\Omega$  resistor limits LT1123 power dissipation and is selected based upon the maximum expected input voltage (see Figure 2).

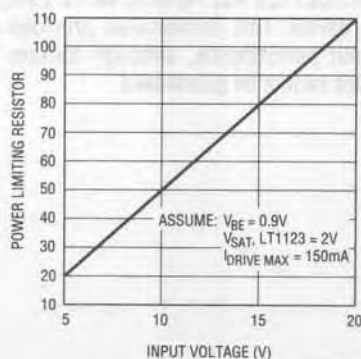
Normally, configurations of this type offer unpredictable short circuit protection. Here, the MJE1123 transistor shown has been specially designed for use with the LT1123. Because of this, beta based current limiting is practical. Excessive output current causes the LT1123 to pull down harder on Q1 until beta limiting occurs. Under these conditions the controlled pull down current combines with Q1's beta and safe operating area characteristics to provide reliable short circuit limiting. Figure 3 details current limit characteristics for 30 randomly selected transistors.



\* = OPTIONAL (SEE TEXT)  
MJE1123 = MOTOROLA

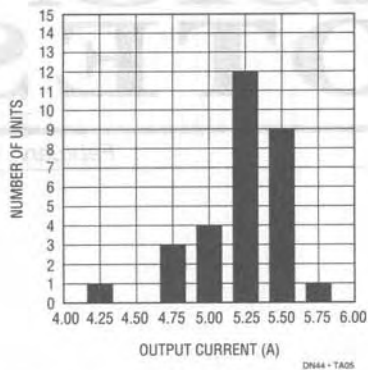
DN44-7A01

**Figure 1. The Ultra-Low Dropout Regulator. LT1123 Combines with Specially Designed Transistor for Lowest Dropout and Short Circuit Protection.**

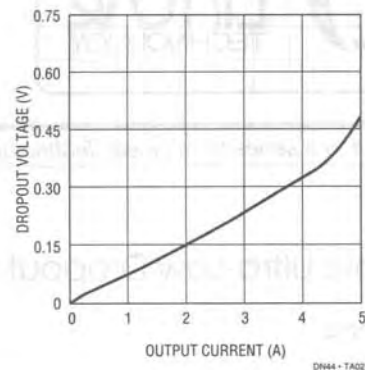


DN44-7A04

**Figure 2. LT1123 Power Dissipation Limiting Resistor Value vs Input Voltage**

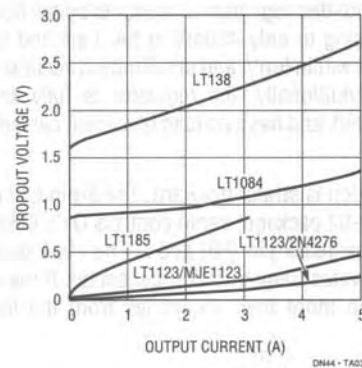


**Figure 3. Short Circuit Current for 30 Randomly Selected MJE1123 Transistors at  $V_{IN} = 7V$**



**Figure 4. Dropout Voltage vs Output Current**

Figure 4 shows dropout characteristics. Even at 5A, dropout is about 450mV, decreasing to only 50mV at 1A. Monolithic regulators cannot approach these figures, primarily because monolithic power transistors do not offer Q1's combination of high beta and excellent saturation. For comparison, Figure 5 compares the circuits performance against some popular monolithic regulators. Dropout is ten times better than 138 types, and significantly better than the other types shown. Because of Q1's high beta, base drive loss is only 1%-2% of output current, even at full 5A output. This maintains high efficiency under the low  $V_{IN} - V_{OUT}$  conditions the circuit will typically operate at. As an exercise, the MJE1123 was replaced with a 2N4276, a Germanium device. This combination provided even lower dropout performance, although current limit characteristics cannot be guaranteed.



**Figure 5. Dropout Voltage vs Output Current for Various Regulators**

For literature on our Low Dropout Regulators, call (800) 637-5545. For applications help, call (408) 432-1900, Ext. 456